

| No | Part                | Qty |
|----|---------------------|-----|
| 1  | Headboard           | 1   |
| 2  | Right Bedside       | 1   |
| 3  | Left Bedside        | 1   |
| 4  | Foot Board          | 1   |
| 5  | Sprung Base         | 1   |
| 6  | Metal Legs          | 4   |
| 7  | Angle Iron          | 2   |
| 8  | Drawer front panel  | 1   |
| 9  | Drawer side panel   | 2   |
| 10 | Drawer back panel   | 1   |
| 11 | Drawer bottom panel | 1   |
| 12 | Shelf support       | 2   |

| HARDWARE FOR BED |                                     |     |
|------------------|-------------------------------------|-----|
| No               | Part                                | Qty |
| A                | Threaded Bolt M8x70                 | 2   |
| B                | Spanner (5mm)                       | 1   |
| C                | Threaded Bolt M8x65                 | 2   |
| D                | Spanner M8/13mm                     | 1   |
| E                | Nut M8                              | 4   |
| F                | Maxiluna Washer $\phi 40 \times 15$ | 4   |
| G                | Cover Cap $\phi 40$                 | 4   |
| H                | Screw M6x45                         | 8   |
| I                | Gasket M8                           | 2   |
| J                | Gasket M6                           | 8   |
| K                | M6x18                               | 8   |
| N                | Quickfit ( $\phi 5 \times 33$ )     | 8   |
| M                | Cam $\phi 15 \times 12$             | 8   |
| O                | Screw $\phi 4 \times 35$            | 16  |
| P                | Foot wheel                          | 4   |
| Q                | Screw $\phi 4 \times 12$            | 8   |
| R                | Screw M6x30                         | 2   |
| S                | Steel connectors                    | 1   |
| T                | Wooden tenon $\phi 8 \times 30$     | 4   |

| HARDWARE FOR BEDFRAME |             |     |
|-----------------------|-------------|-----|
| No                    | Part        | Qty |
| E                     | Nut M8      | 11  |
| I                     | Gasket M8   | 22  |
| L                     | Screw M8x45 | 8   |
| M                     | Screw M8x70 | 3   |

- Please check contents and read instructions before commencing assembly.
- Please use a soft mat to avoid damaging during assembly
- Assemble this article following the enclosed instructions carefully.

|  |       |  |    |
|--|-------|--|----|
|  |       |  |    |
|  | 30min |  | X1 |

STEP 1

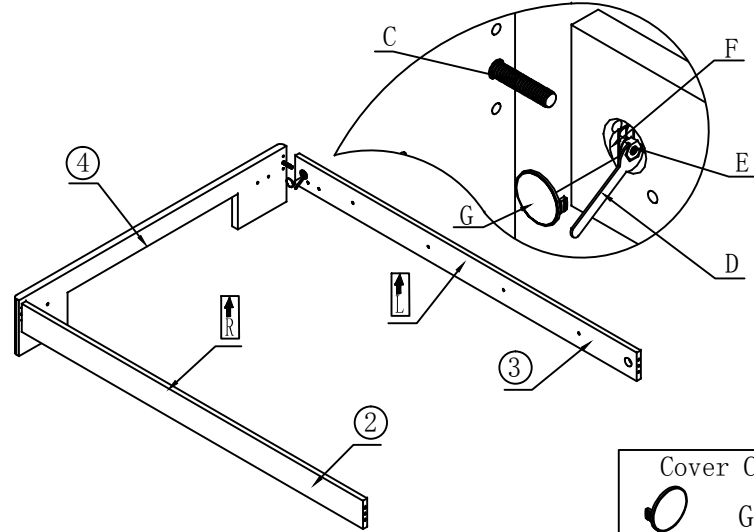

|  |                     |  |           |
|--|---------------------|--|-----------|
|  | Cover Cap $\phi 40$ |  | Gx2       |
|  | $\phi 40 \times 15$ |  | Nut M8    |
|  | Fx2                 |  | Ex2       |
|  | M8x65               |  | M8 / 13mm |
|  | Cx2                 |  | Dx1       |

STEP 2

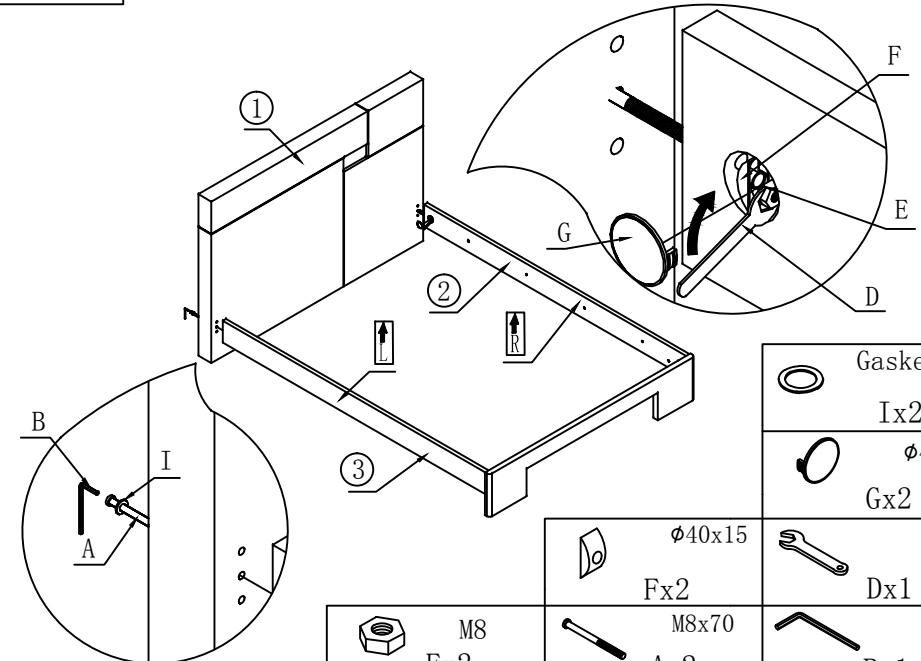

|  |                     |  |       |
|--|---------------------|--|-------|
|  | Gasket M8           |  | Ix2   |
|  | $\phi 40$           |  | Gx2   |
|  | $\phi 40 \times 15$ |  | Dx1   |
|  | M8                  |  | M8x70 |
|  | Ex2                 |  | Ax2   |
|  |                     |  | Bx1   |

STEP 3

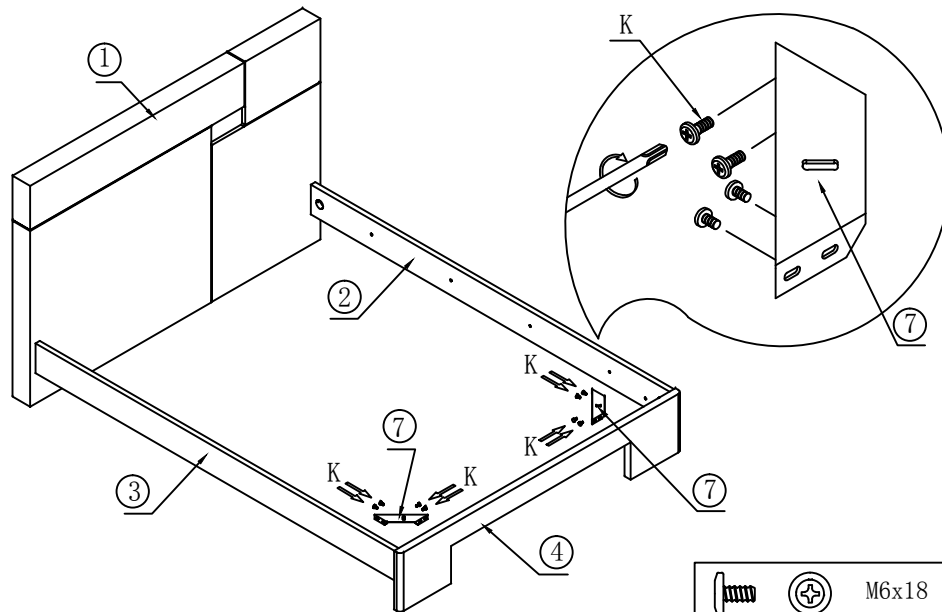

|  |  |       |
|--|--|-------|
|  |  | M6x18 |
|  |  | Kx8   |

STEP 4

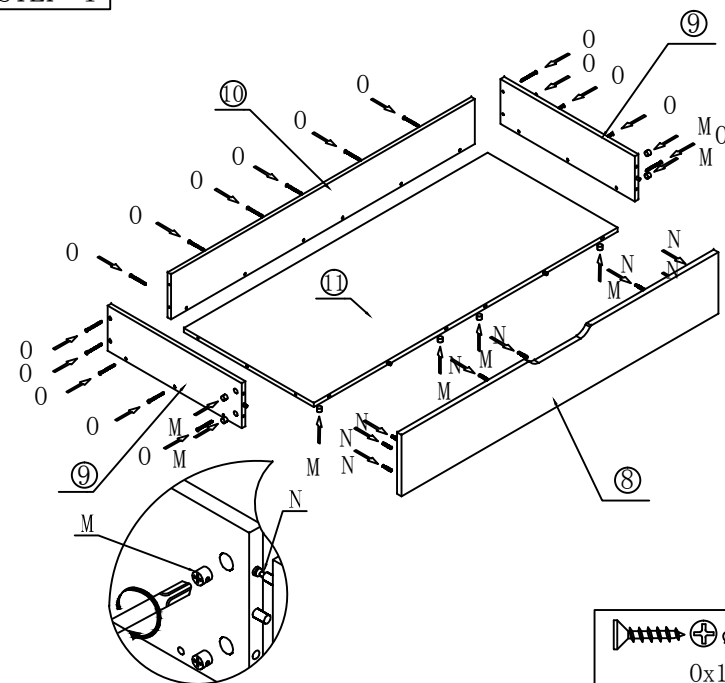

|  |  |                     |
|--|--|---------------------|
|  |  | $\phi 5 \times 33$  |
|  |  | Nx8                 |
|  |  | $\phi 4 \times 35$  |
|  |  | Ox16                |
|  |  | $\phi 15 \times 12$ |
|  |  | Mx8                 |

STEP 5

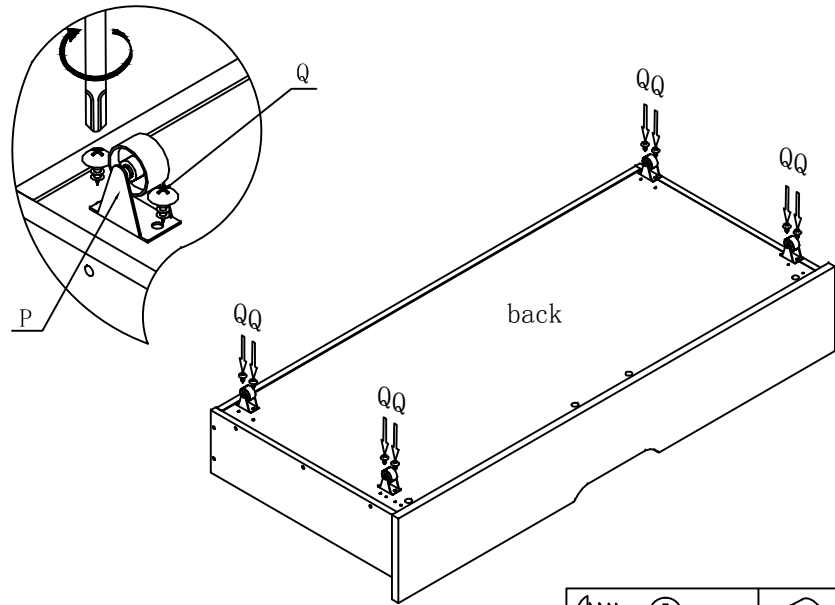

- |  |                     |  |            |
|--|---------------------|--|------------|
|  | $\odot$ $\Phi$ 4X12 |  | Foot wheel |
|  | Qx8                 |  | Px4        |

STEP 6

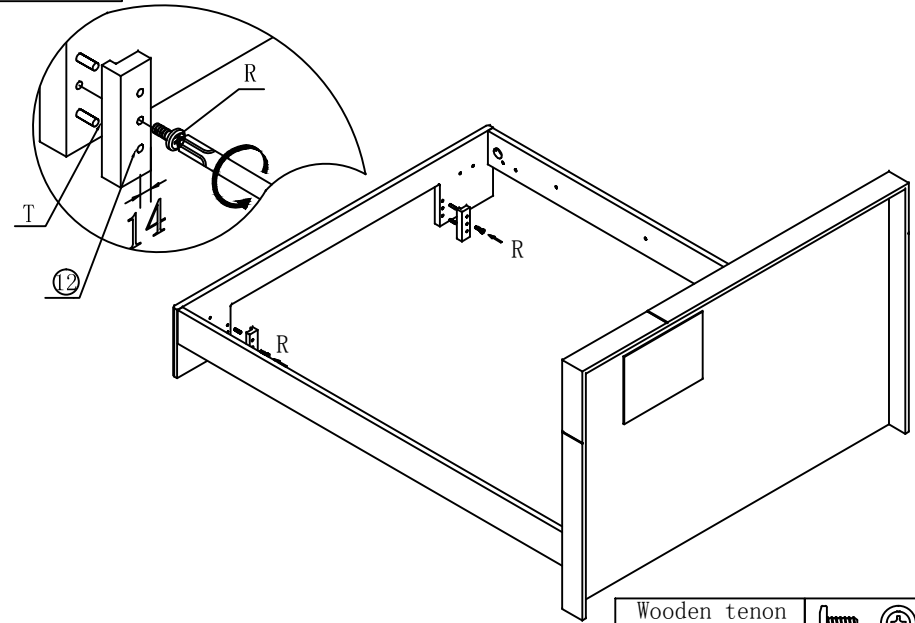

- |             |              |  |               |
|-------------|--------------|--|---------------|
|             | Wooden tenon |  | $\odot$ M6x30 |
| $\Phi$ 8X30 | Tx4          |  | Rx2           |

STEP 7

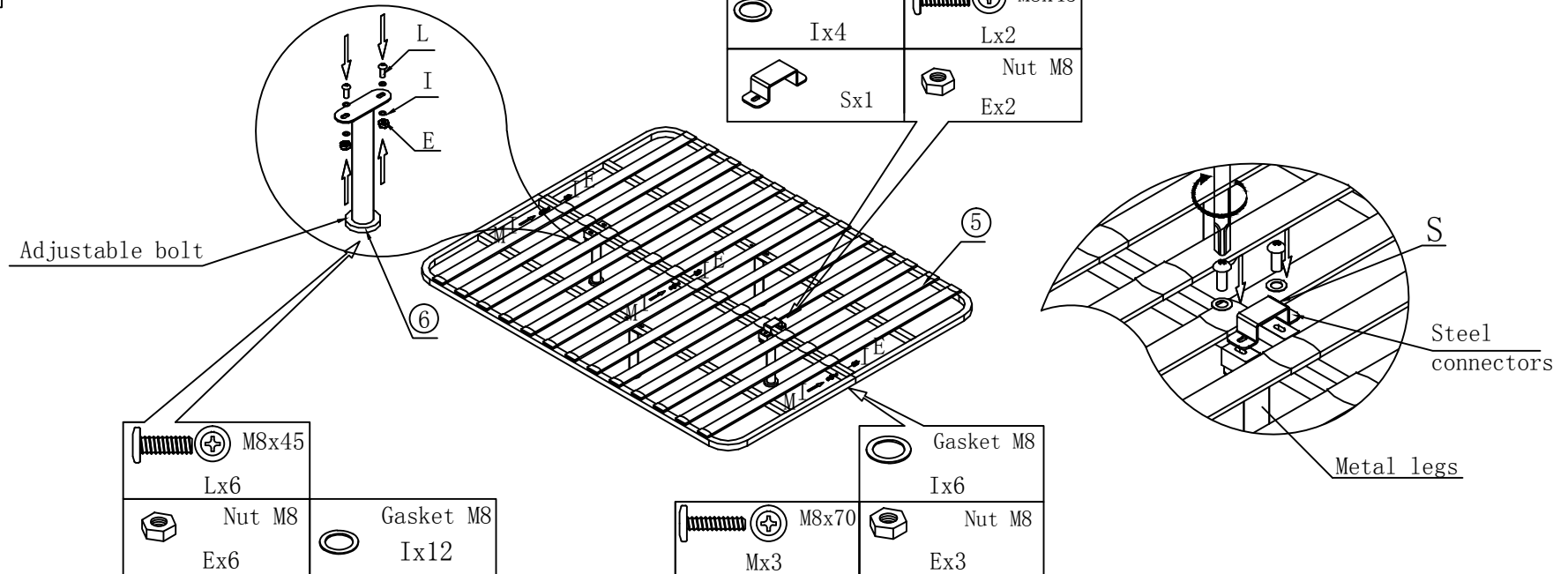

- |     |           |     |        |
|-----|-----------|-----|--------|
|     | Gasket M8 |     | M8x45  |
| Ix4 |           | Lx2 |        |
|     | Sx1       |     | Nut M8 |
|     |           | Ex2 |        |

- |     |        |      |           |
|-----|--------|------|-----------|
|     | M8x45  |      | Gasket M8 |
| Lx6 |        | Ix12 |           |
|     | Nut M8 |      |           |
| Ex6 |        |      |           |

- |     |       |     |        |
|-----|-------|-----|--------|
|     | M8x70 |     | Nut M8 |
| Mx3 |       | Ex3 |        |

STEP 8

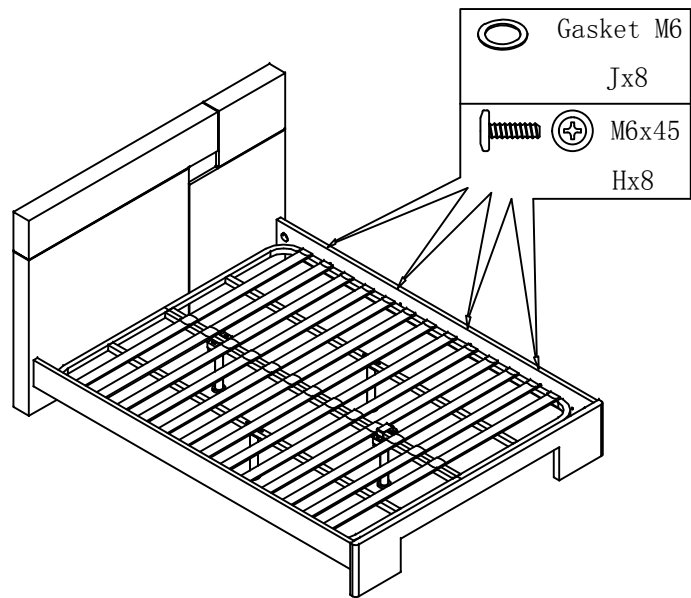

STEP 9

