

ASSEMBLY INSTRUCTIONS



Fine Furniture for every stage of life

Daybed

ASSEMBLY INSTRUCTIONS

ASSEMBLY TIPS:

1. Remove hardware from box and sort by size.
2. Please check to see that all hardware and parts are present prior to start of assembly.
3. Please follow attached instructions in the same sequence as numbered to assure fast & easy assembly.



WARNING!

1. Don't attempt to repair or modify parts that are broken or defective. Please contact the store immediately.
2. This product is for home use only and not intended for commercial establishments.







ASSEMBLY TIME

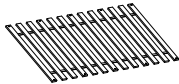
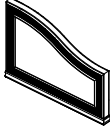

15 MINUTES

PARTS IDENTIFICATION

B1 (BOX 1)



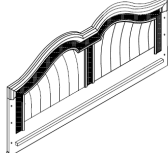





<p>A RIGHT SIDE PANEL WITH LABEL "A"</p>  <p>C LEG WITH LABEL "C"</p>  <p>E ROLL SLAT (13PCS)</p> 	<p>1PC</p> <p>2PCS</p> <p>1SET</p>	<p>B LEFT SIDE PANEL WITH LABEL "B"</p>  <p>D LEG WITH LABEL "D"</p> 	<p>1PC</p> <p>2PCS</p>
---	------------------------------------	---	------------------------

B2 (BOX 2)

<p>F BACK PANEL</p> 	<p>1PC</p>	<p>G FRONT RAIL</p> 	<p>1PC</p>
--	------------	--	------------

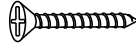
HARDWARE IDENTIFICATION

Z-B1(BOX 1) - HARDWARE PACK IS LOCATED IN 360121 (B1)

<p>1 BOLT (Ø5/16" x 55 mm - RBW)</p>  <p>3 FLAT WASHER (Ø5/16" - RBW)</p>  <p>5 THREADED BOLT (Ø5/16" x 90MM - RBW)</p>  <p>7 HEX NUT (Ø5/16" x 14MM - RBW)</p>  <p>9 FLAT HEAD SCREW (Ø4 x 30MM - RBW)</p> 	<p>14PCS</p> <p>14PCS</p> <p>4PCS</p> <p>4PCS</p> <p>10PCS</p>	<p>2 LOCK WASHER (Ø5/16" - RBW)</p>  <p>4 ALLEN WRENCH (4MM - RBW)</p>  <p>6 HALF ROUND NUT (Ø5/16" - RBW)</p>  <p>8 WRENCH (14MM - RBW)</p> 	<p>14PCS</p> <p>1PC</p> <p>4PCS</p> <p>1PC</p>
--	--	---	--

NOTE:

Phillips head screw driver is required in the assembly process; however, manufacturer does not provided this item.

ASSEMBLY INSTRUCTIONS

STEP 1

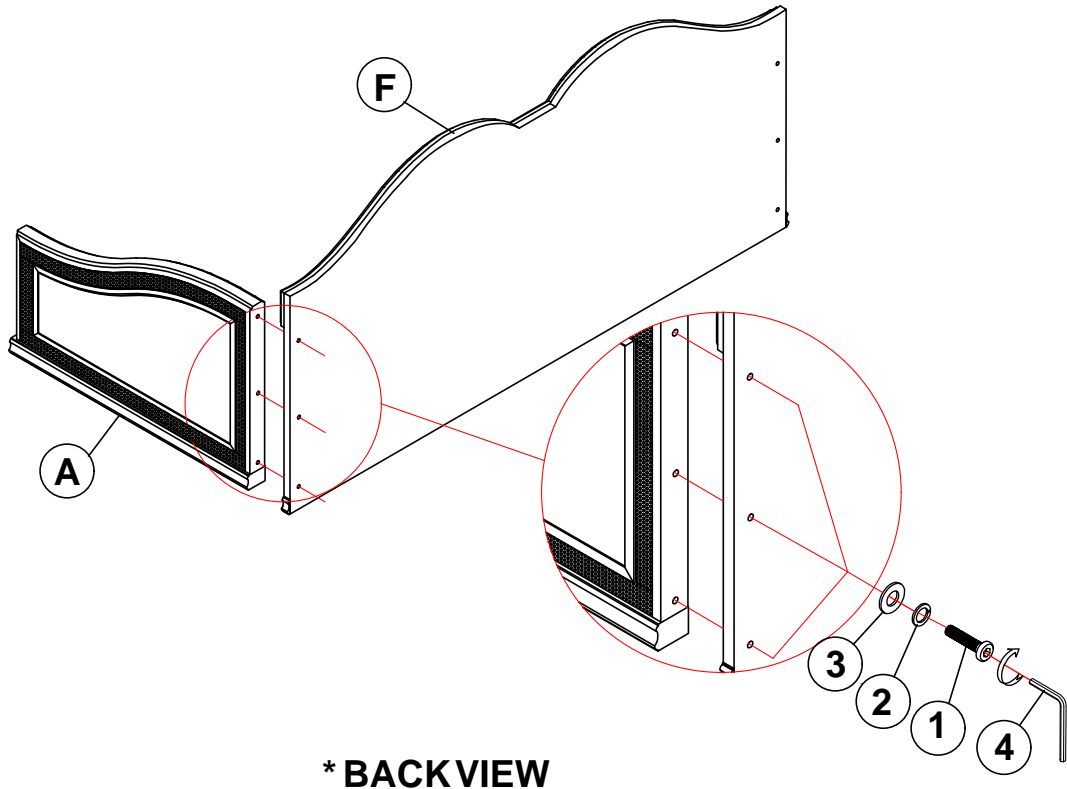

STEP 2

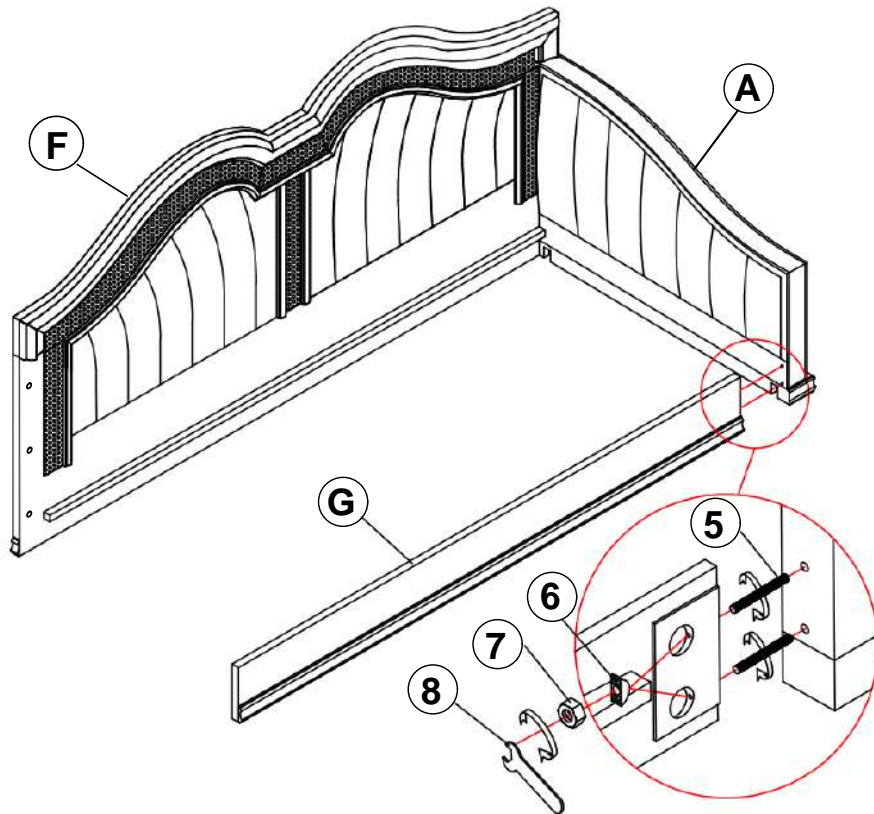

ASSEMBLY INSTRUCTIONS

STEP 3

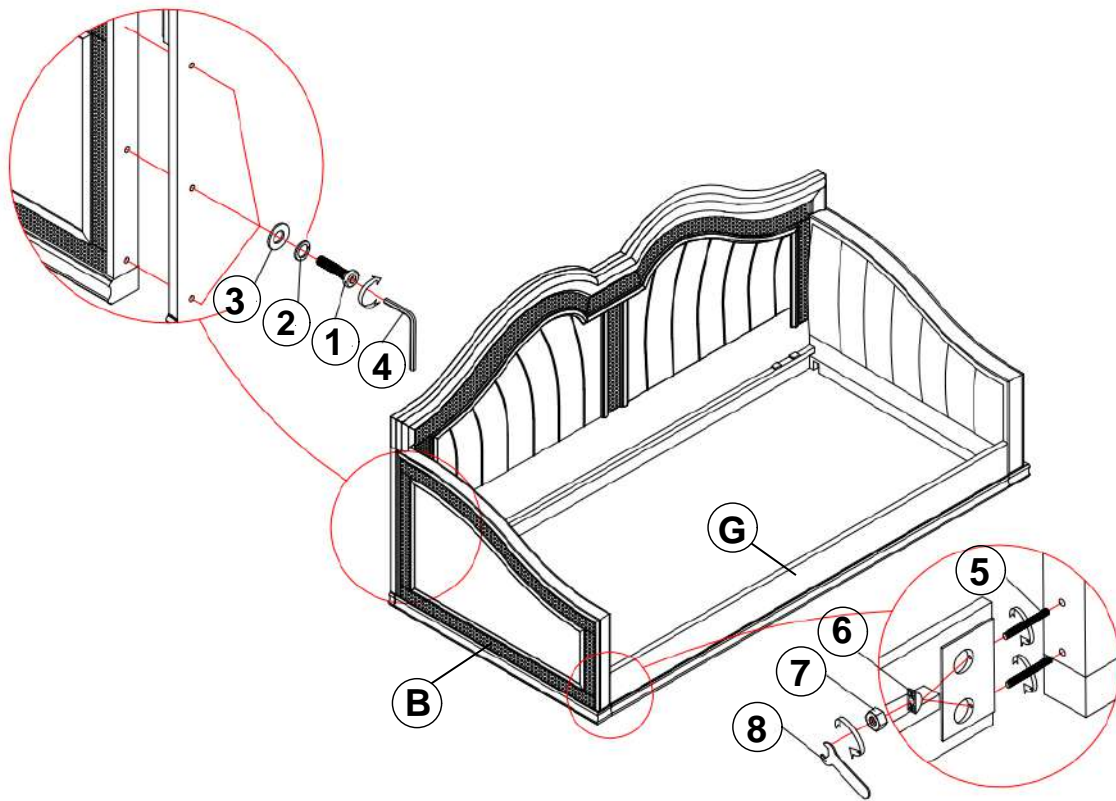

STEP 4

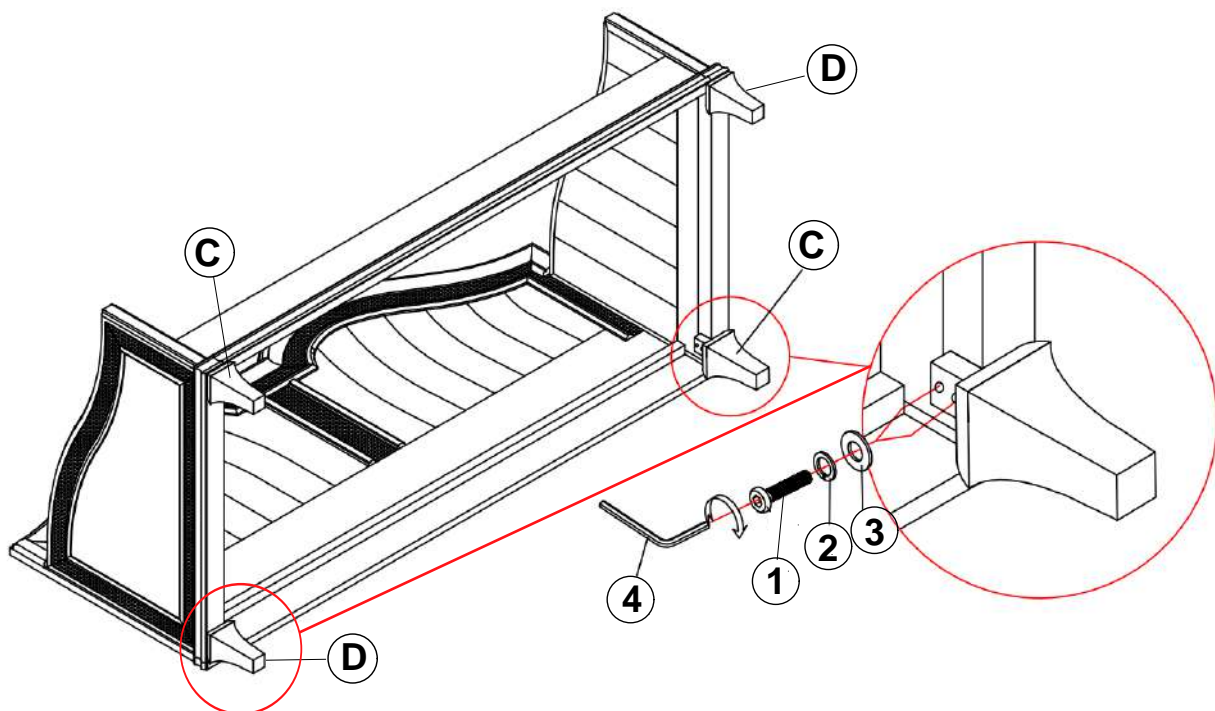

ASSEMBLY INSTRUCTIONS

STEP 5

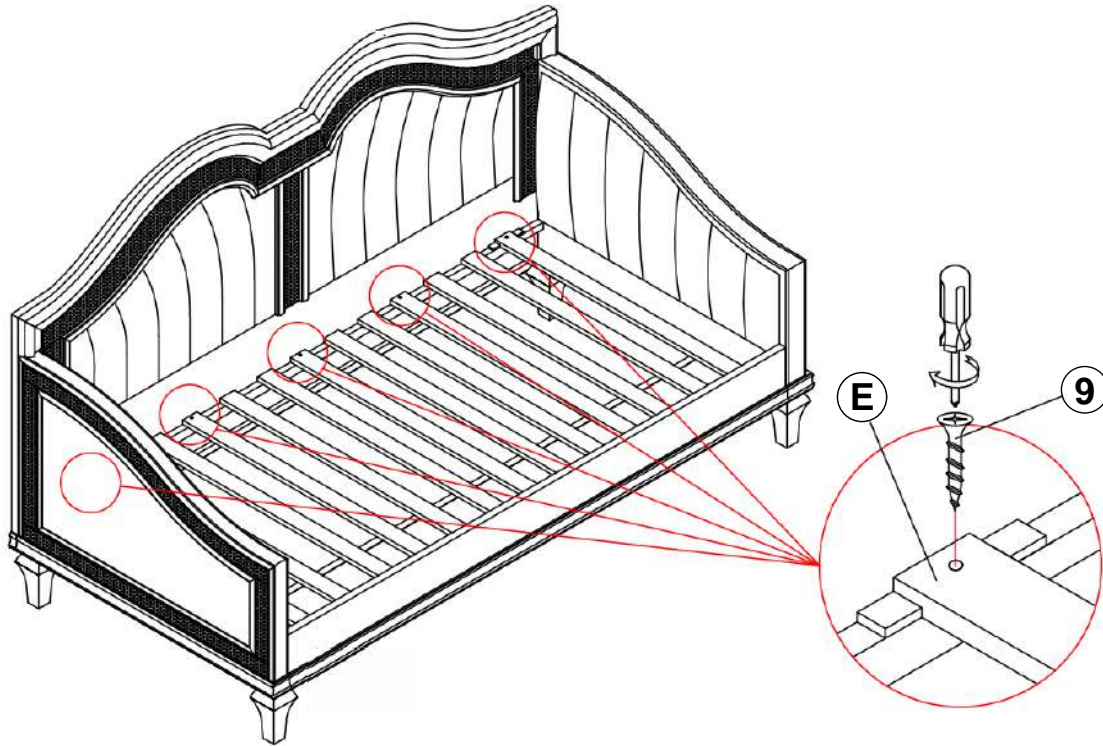

STEP 6

COMPLETE

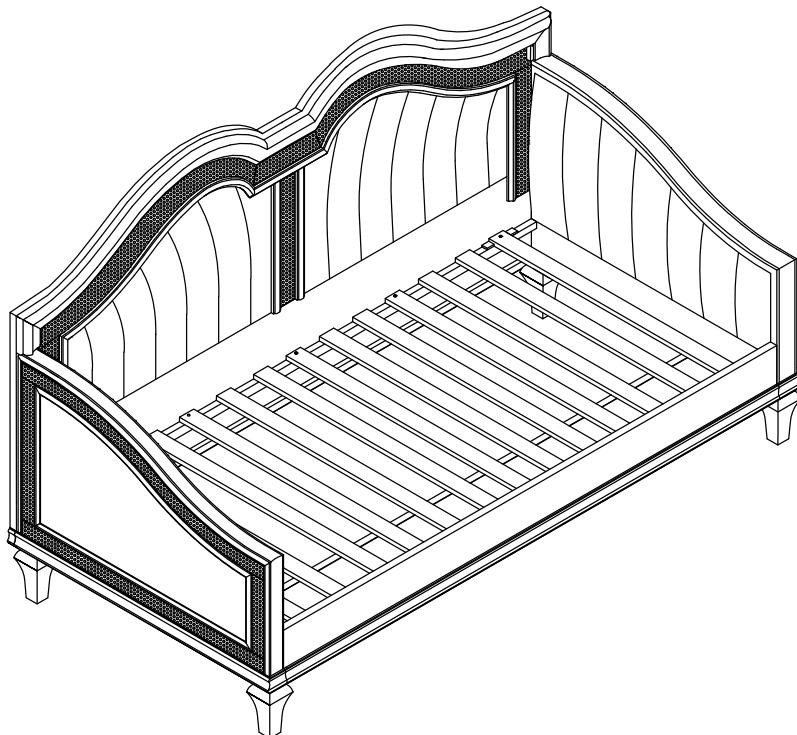

Inner Size : 78.75"W X 39.75"D

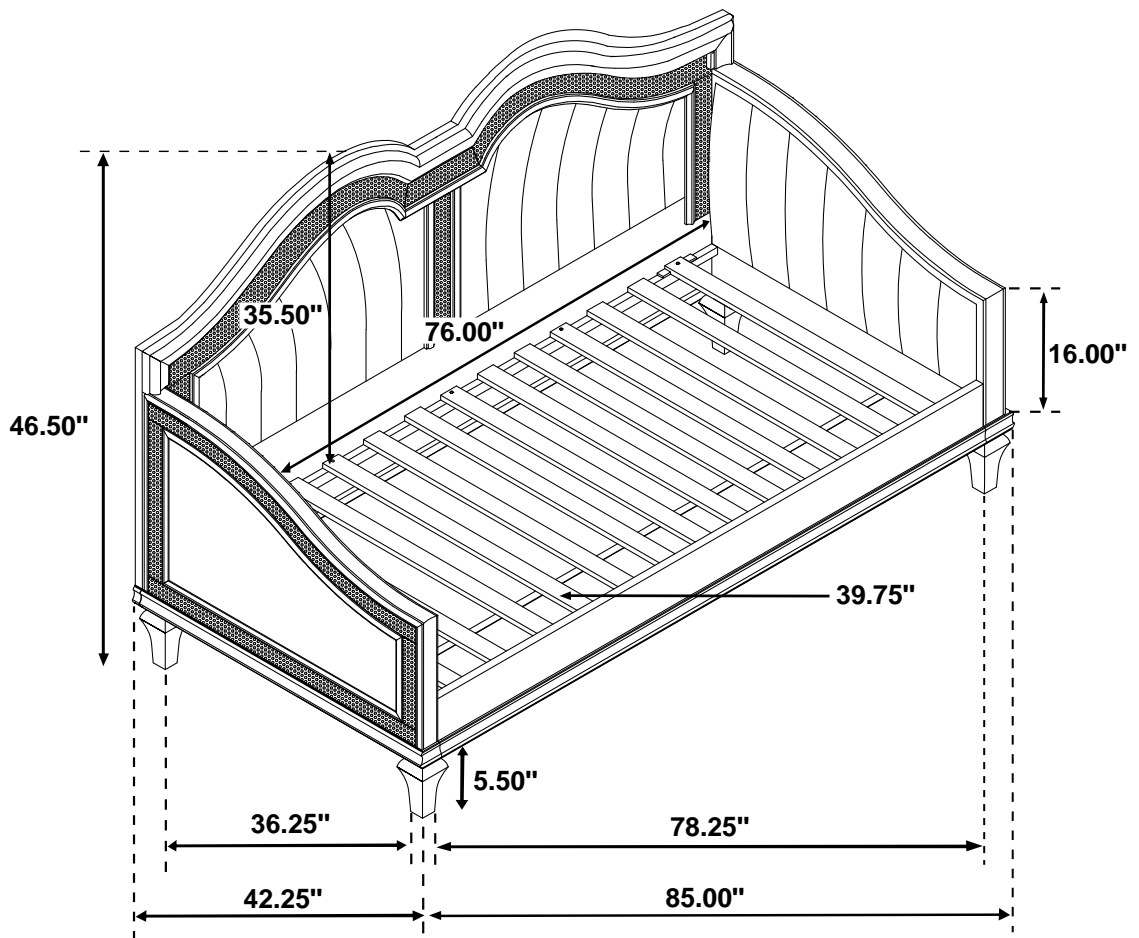

Note: Dimension tolerance $\pm 5\%$