









ASSEMBLY INSTRUCTIONS & PARTS IDENTIFICATION TELLURIDE DRIFWOOD DINING HEIGHT EXTENSION TABLE

Thank you for purchasing this quality product. Be sure to check all packing material carefully for small parts that may have come loose inside the carton during shipment.

Parts key				Hardware Kit			
No	Code	Qty	Description	No	Description		Qty
1	A	1 pc	Table Top	A	 Bolt	Ø7.8 x 50	4 pcs
2	B	4 pcs	Leg - Dining Height	B	 Bolt	Ø7.8 x 40	1 pc
3	C	1 pc	Lower Stretcher- Dining Height	C	 Hex Nut	Ø8	8 pcs
4	D	1 pc	Upper Stretcher- Dining Height	D	 Semi lunar washer	Ø8 x 30	4 pcs
5	E	4 pcs	Apron Spacer	E	 Lock washer	Ø8	13 pcs
6	F	2 pcs	Extension Mechanism	F	 Small Flat washer	Ø8 x 18	1 pc
7	G	1 pc	Mounting board - Long	G	 Small Flat washer	Ø10 x 22	8 pcs
8	H	2 pcs	Mounting board - Short	H	 Allen Key	K4	1 pc
9	I	4 pcs	Extension Lock	I	 Wrench	12	1 pc
10	J	4 pcs	Leveler				

PLEASE NOTE: Assembly requires two people. Follow directions step by step.
Do not use power tools to assemble

Step:01

- Put the 2 stretchers (3 & 4) together using the small flat washer (F), lock washer (E) and short bolt (B) as shown.

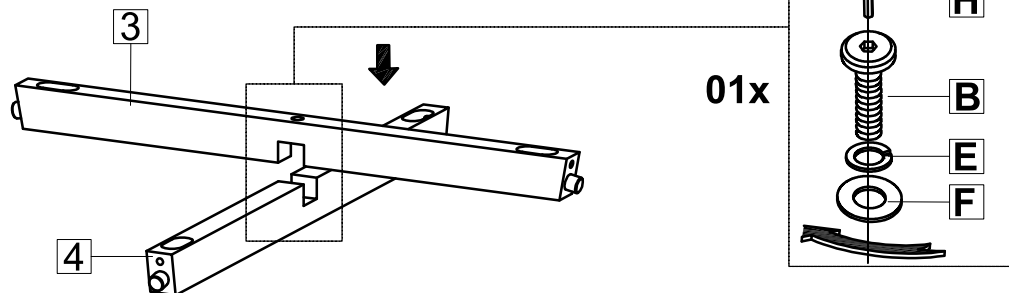

Step:02

- Carefully place the top on smooth flat surface to avoid scratches.
- Attach the table legs to the appropriate positions.

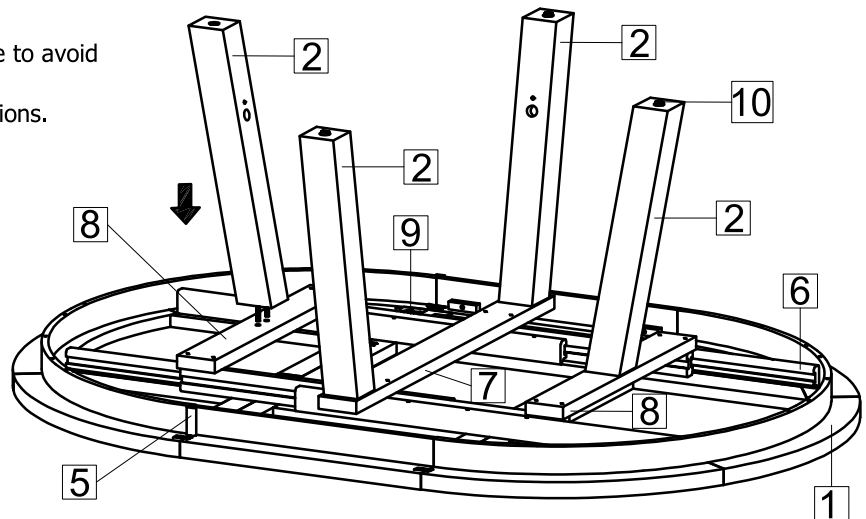
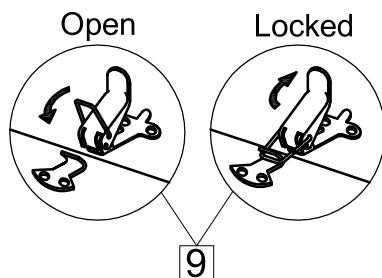

ASSEMBLY INSTRUCTIONS & PARTS IDENTIFICATION TELLURIDE DRIFWOOD DINING HEIGHT EXTENSION TABLE

Step:03

-Insert the stretcher assembly between the legs using the dowels to line up the position.
-Attach the stretchers to the legs with Bolt B, Lock Washer E and washer D (placed as shown).
Tighten with Allen key .

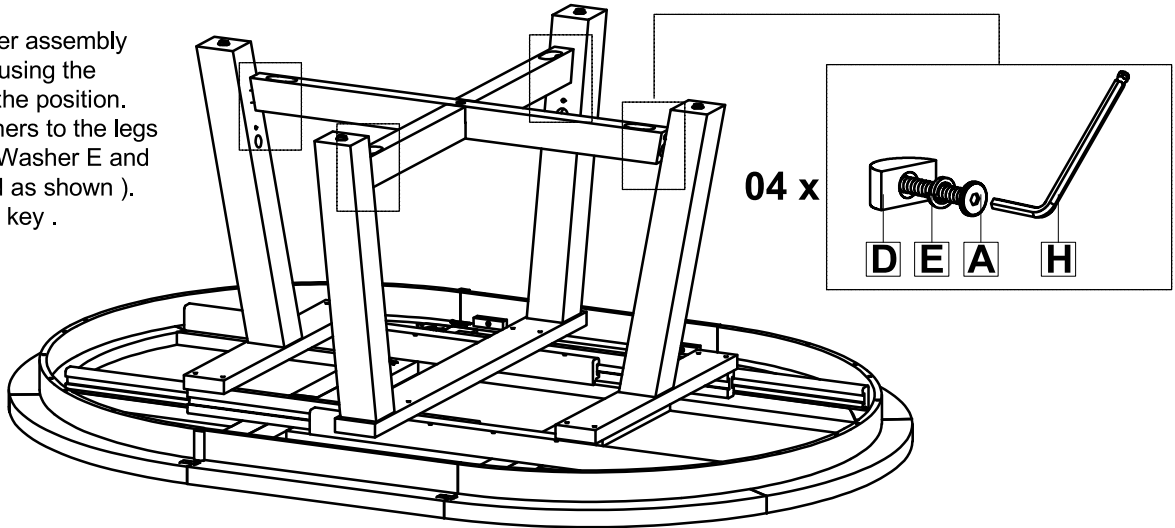

Step:04

- Attach the legs to the mounting boards with a Flat Washer G, Lock Washer E and Nut C using the wrench provided.
- Before turning the table over for use, make sure that the legs are tight and the table extension locks holding the leaf are locked.

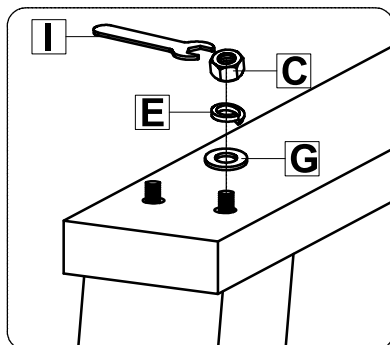



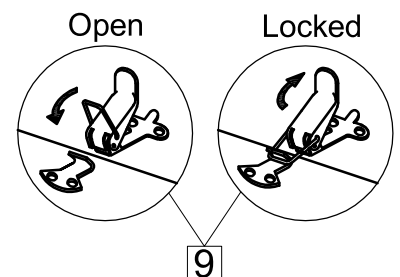
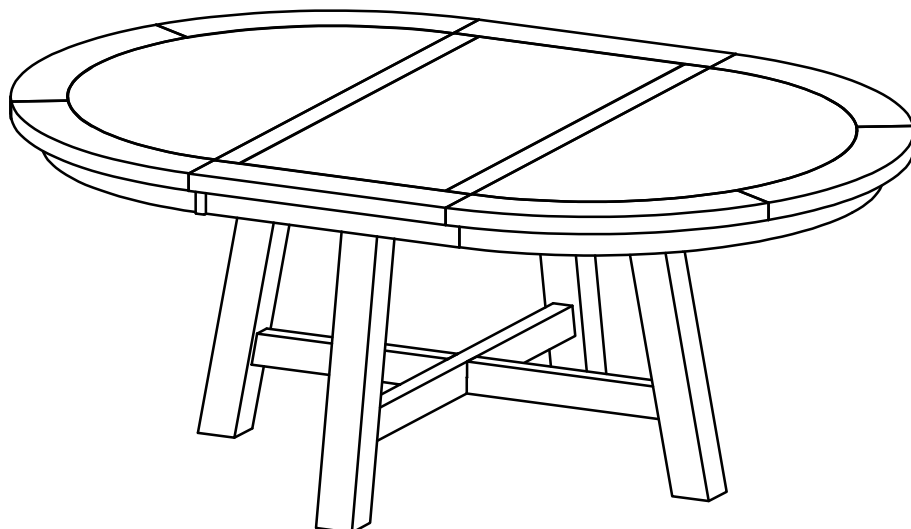
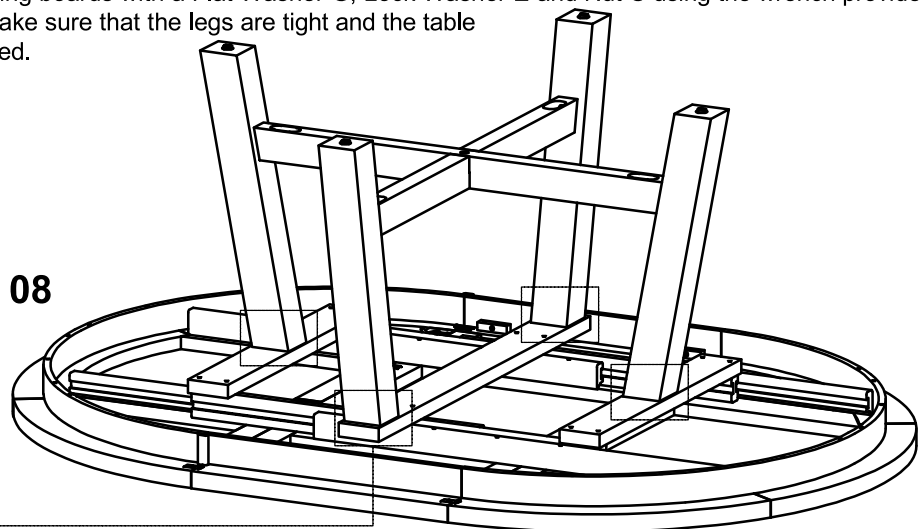



x 08



ASSEMBLY INSTRUCTIONS & PARTS IDENTIFICATION

TELLURIDE DRIFWOOD DINING CHAIR

Thank you for purchasing this quality product. Be sure to check all packing material carefully for small parts that may have come loose inside the carton during shipment. **DO NOT** use power tools to assembly.

Parts key				Hardware Kit			
No	Code	Qty	Description	No	Code	Qty	Description
1	A	1 pc	Chair Back	A		4 pcs	Long Bolt Ø7.8 x 80mm
2	B	1 pc	Complete Seat	B		4 pcs	Medium Bolt Ø7.8 x 50mm
3	C	2 pcs	Front Leg	C		3 pcs	Short Bolt Ø7.8 x 35mm
4	D	4 pcs	Floor glide	D		11 pcs	Lock Washer Ø8.5
				E		11 pcs	Flat Washer Ø8.5
				F		1 pc	Allen Key

STEP:01

- Carefully lay Chair Back flat on a smooth flat surface to prevent scratches.
- Affix Complete Seat to Chair Back by inserting a Flat Washer, Lock Washer and Short Screw (C) into each of the hole on the back of the seat. Don't fully tighten at this point. (See Detail A).
- Insert a Flat Washer, Lock Washer and Long K.D. Screw into each of 2 holes in the Complete Seat corners. Tighten screws with provided Key Wrench. (See Detail B). Tighten the three bolts in the center of the seat back.

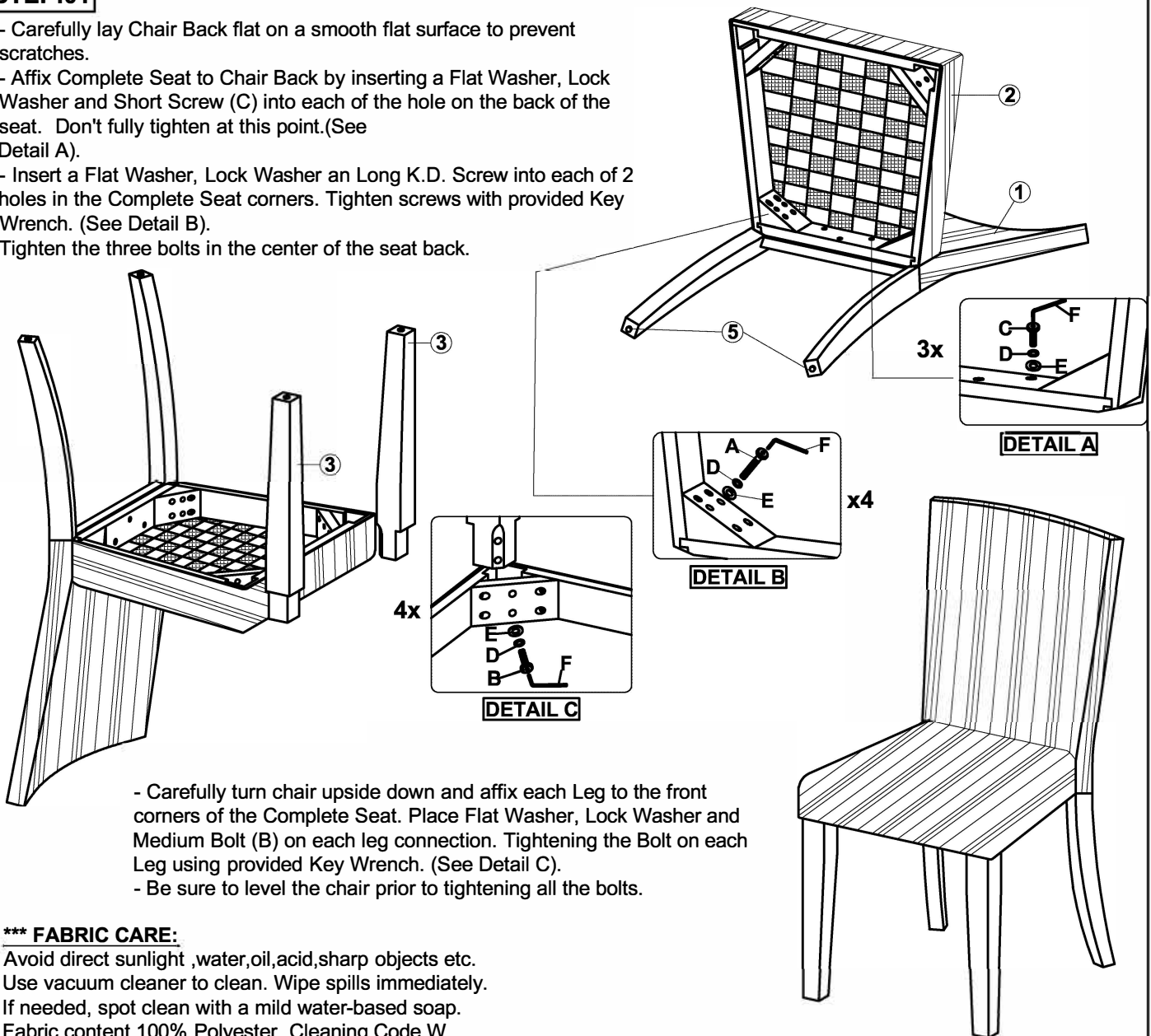

- Carefully turn chair upside down and affix each Leg to the front corners of the Complete Seat. Place Flat Washer, Lock Washer and Medium Bolt (B) on each leg connection. Tightening the Bolt on each Leg using provided Key Wrench. (See Detail C).
- Be sure to level the chair prior to tightening all the bolts.

*** FABRIC CARE:

Avoid direct sunlight, water, oil, acid, sharp objects etc.
Use vacuum cleaner to clean. Wipe spills immediately.
If needed, spot clean with a mild water-based soap.
Fabric content 100% Polyester, Cleaning Code W