

# ASSEMBLY INSTRUCTIONS

---

## 72" Wide Single Pedestal Desk

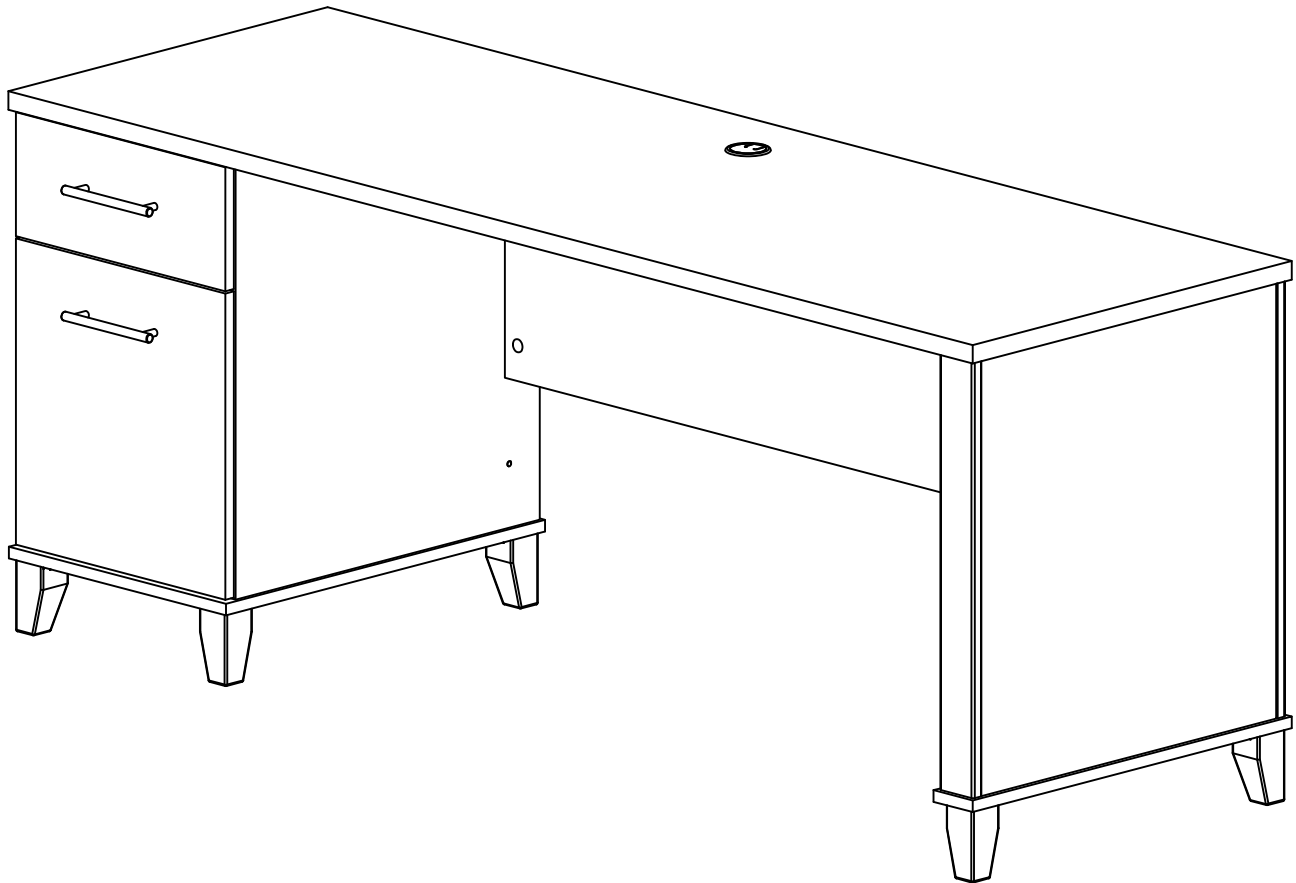

Lot Code #



## WARNING

Units must be assembled with the instructions, parts and hardware provided. Improper assembly or use could cause structural failure, instability, tip over, and/or serious injury.

Las unidades deben ser ensambladas de acuerdo a las instrucciones y usando el herraje incluido. El ensamblado incorrecto puede causar un fallo estructural, inestabilidad, o que la unidad se derrumbe, causando posibles heridas personales.

Les unités doivent être assemblées avec les instructions et les matériels donnés. Si vous ne le construisez pas correctement ceci pourrait causer des dommages structuraux, instabilité, se renverser et blesser quelqu'un.



## WARNING

Do not move unit when loaded. Doing so could cause instability, product collapse, tip over, and/or serious injury.

No mueva la unidad cuando esté cargada. Hacerlo puede causar inestabilidad, que el producto se derrumbe, que se la caiga encima y/o heridas (golpes) serias.

Ne pas déplacer l'unité lorsqu'elle est chargée. Faire ainsi peut causer l'instabilité, l'effondrement ou le renversement du meuble et/ou des endommagements sérieux.

# EXPLODED VIEW

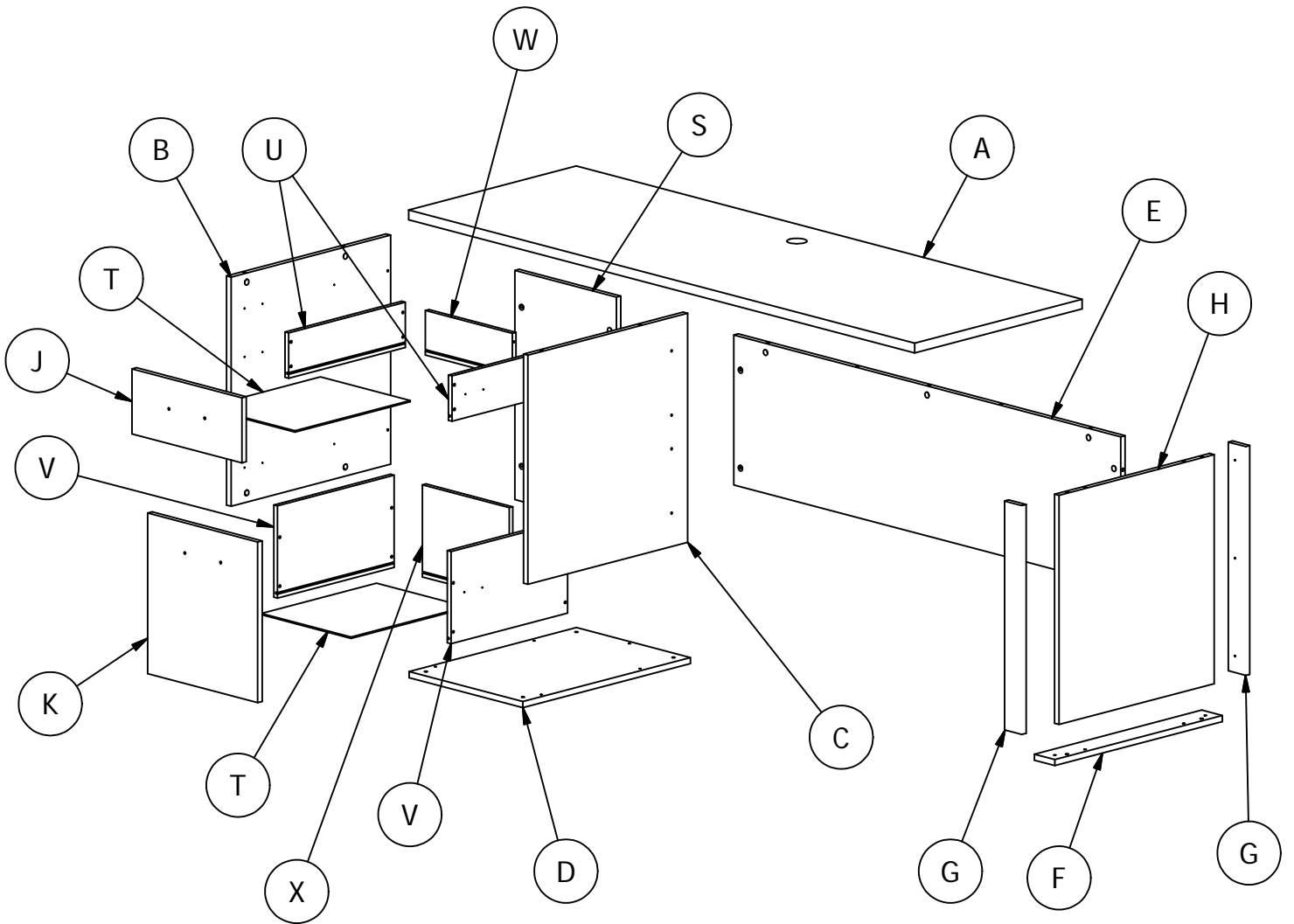
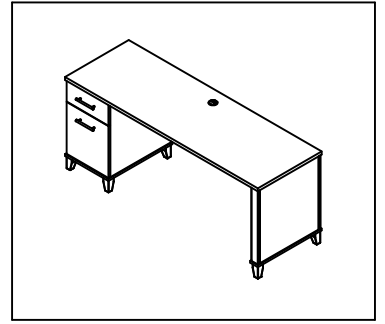

# PARTS LIST

---

# FASTENERS

Fasteners are shown in actual size.  
los fijadores son demostrados en su tamaño actual.  
les attaches sont montrées dans l'échelle grandeur.

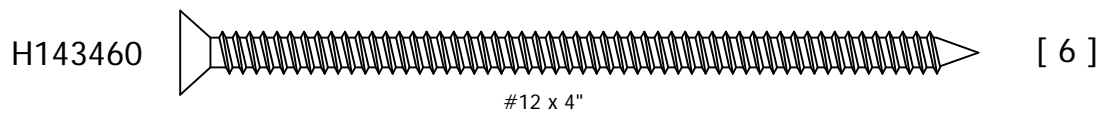
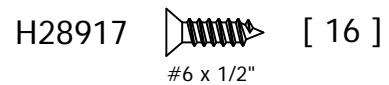
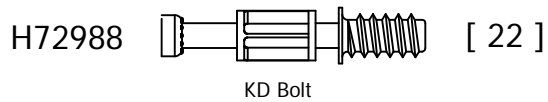
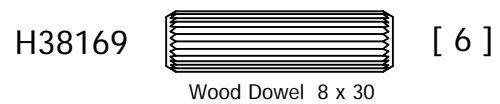
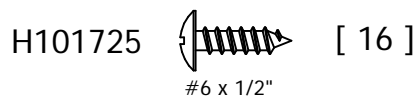
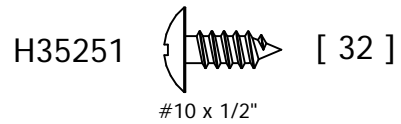
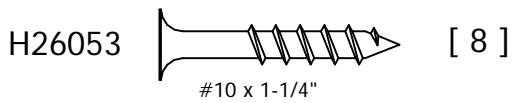
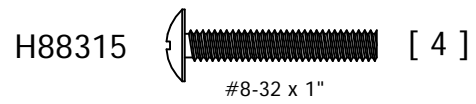
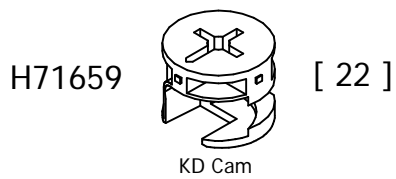
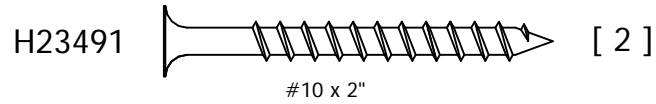

# HARDWARE

H100445

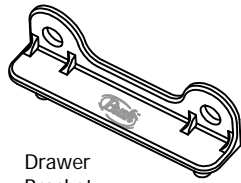

Drawer  
Bracket

[ 2 ]

H67187

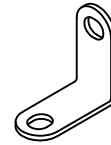

Angle Bracket

[ 6 ]

Z89901

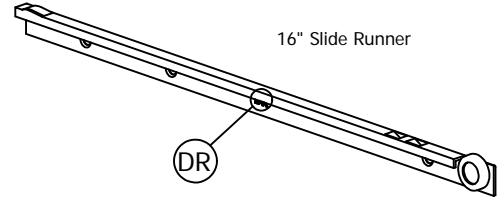

[ 1 ]

Z89898

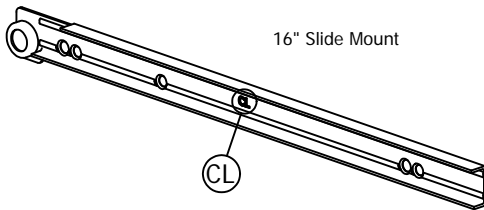

[ 1 ]

Z89899

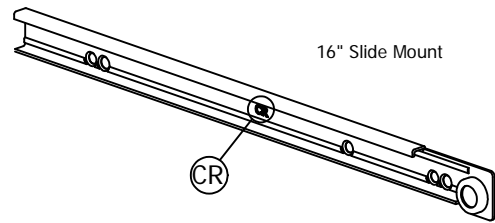

[ 1 ]

H162488

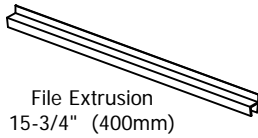

File Extrusion  
15-3/4" (400mm)

[ 2 ]

H150001

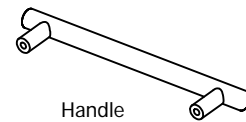

Handle

[ 2 ]

Z89900

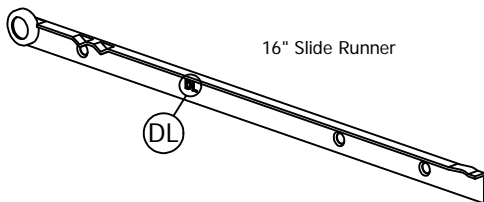

[ 1 ]

Z162814

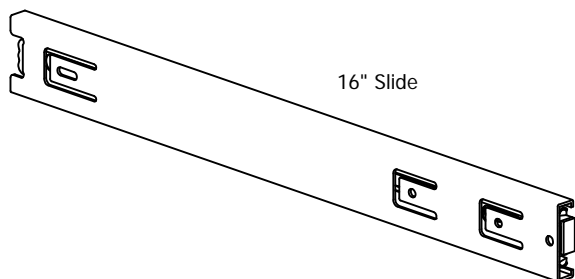

[ 2 ]

H100446

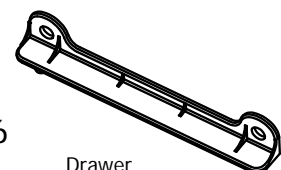

Drawer  
Bracket

[ 2 ]

# MODEL SPECIFIC

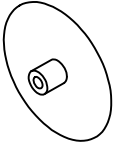
H87676  [ 9 ]  
Cover Cap

H100012  [ 3 ]  
5mm Hole Plug

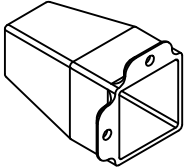
H149999  [ 6 ]  
Foot

H187287  [ 6 ]  
3mm Hole Plug

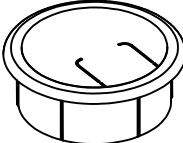
H118700  [ 1 ]  
Grommet

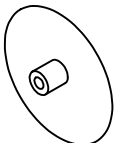
H83021  [ 9 ]  
Cover Cap

H112099  [ 3 ]  
5mm Hole Plug

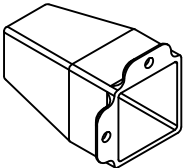
H149999  [ 6 ]  
Foot

H187286  [ 6 ]  
3mm Hole Plug

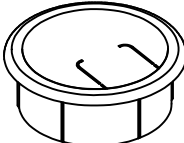
H151406  [ 1 ]  
Grommet

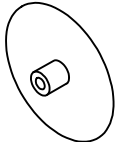
H95137  [ 9 ]  
Cover Cap

H96110  [ 3 ]  
5mm Hole plug

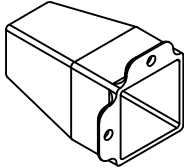
H149999  [ 6 ]  
Foot

H176845  [ 6 ]  
3mm Hole Plug

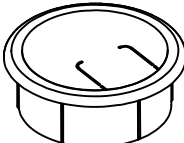
H118700  [ 1 ]  
Grommet

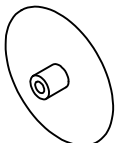
H73621  [ 9 ]  
Cover Cap

H63904  [ 3 ]  
5mm Hole Plug

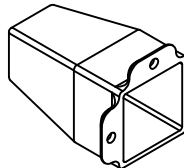
H177601  [ 6 ]  
Foot

H171232  [ 6 ]  
3mm Hole Plug

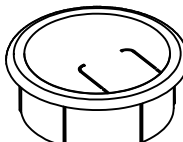
H118700  [ 1 ]  
Grommet

# STEP 1

H38169

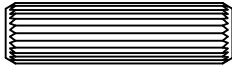

Wood Dowel 8 x 30

[ 2 ]

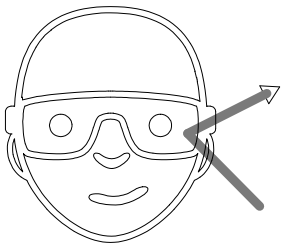
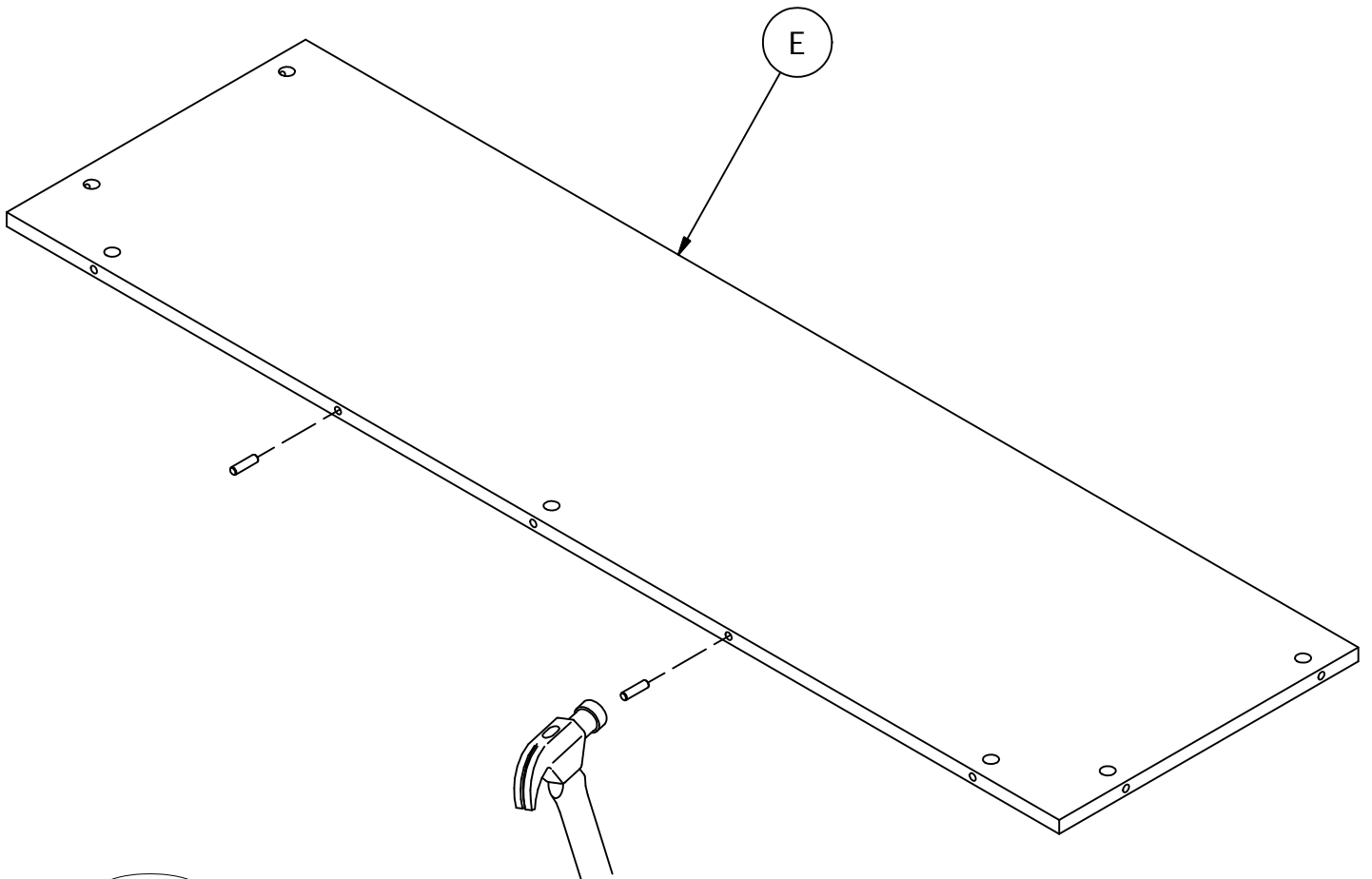

Safety glasses  
Gafas de seguridad  
Lunettes de protection

# STEP 2

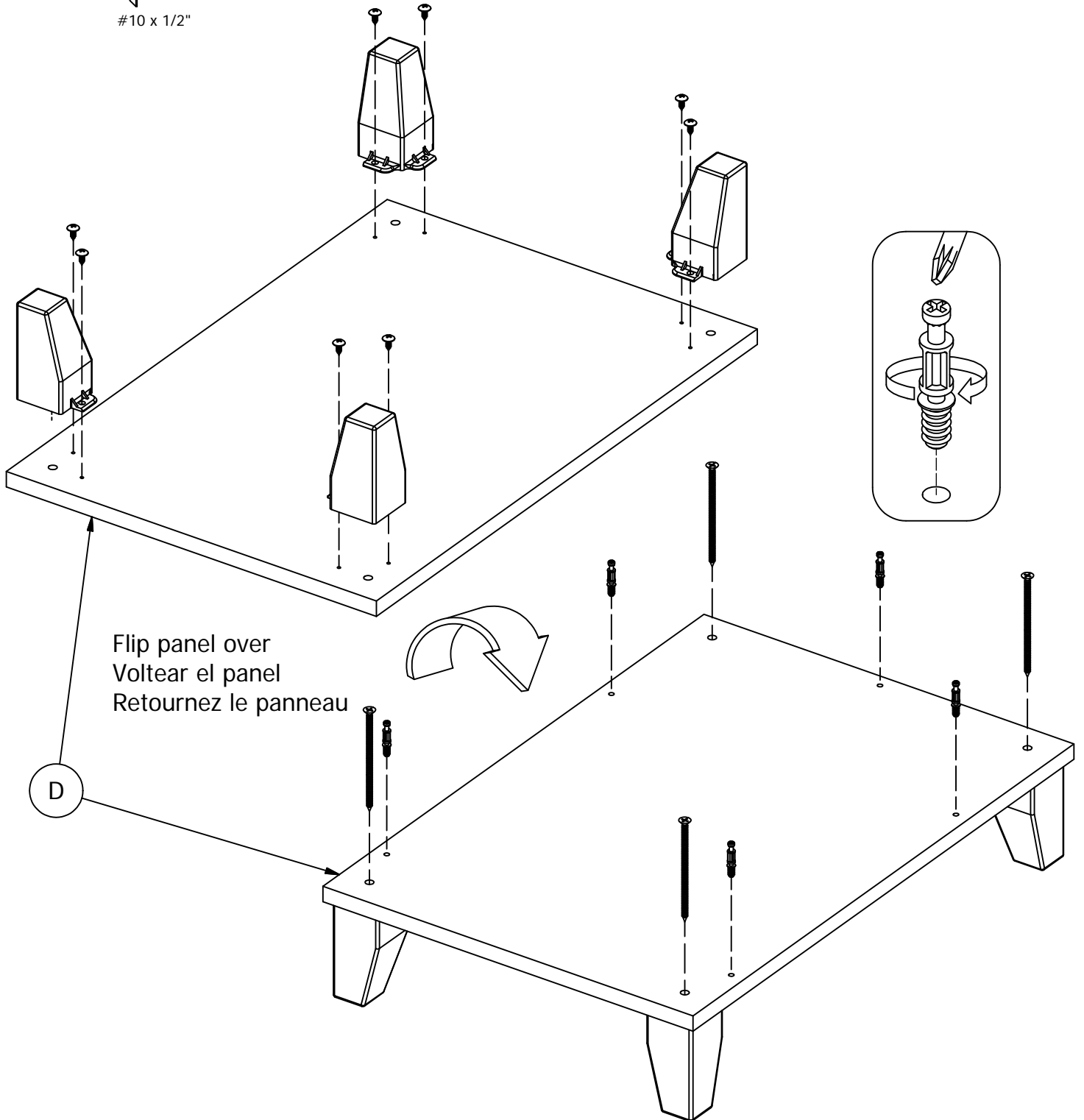
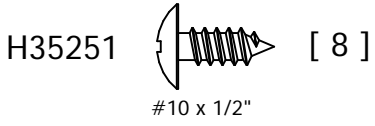
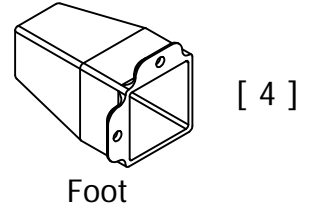
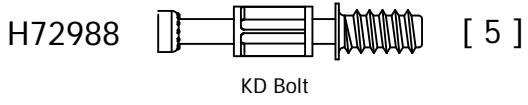
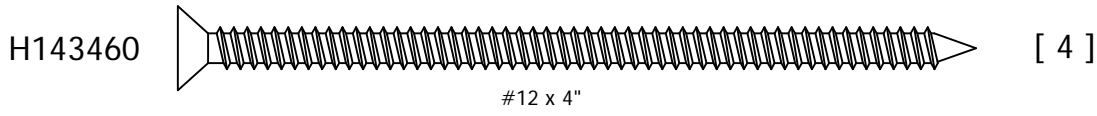

# STEP 3

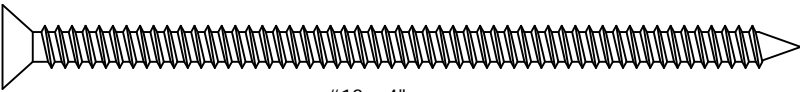
H143460  [ 2 ]  
#12 x 4"

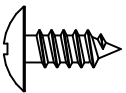
H35251  [ 4 ]  
#10 x 1/2"

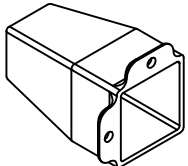
 [ 2 ]  
Foot

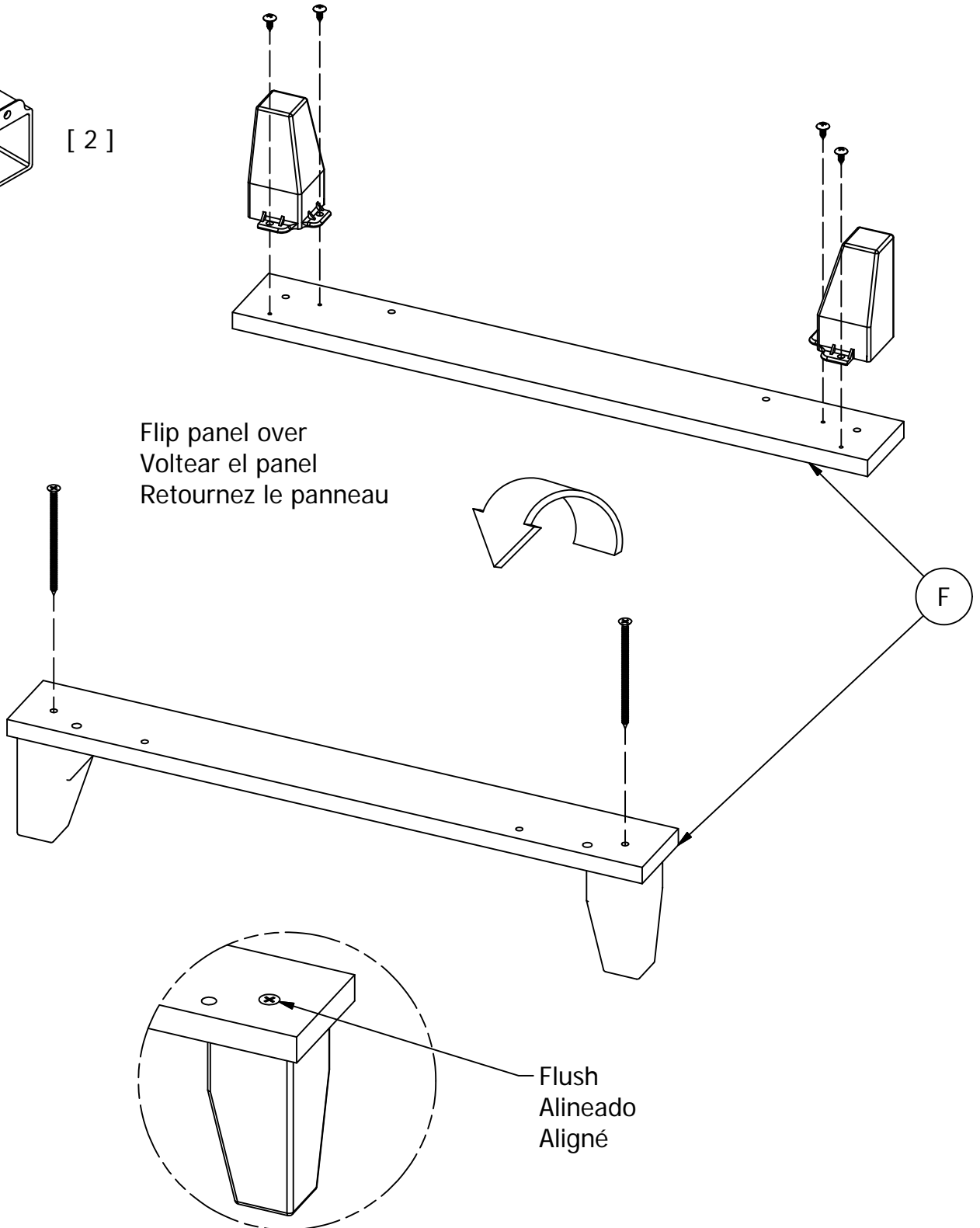

# STEP 4

H67187

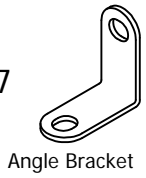

[ 6 ]

Do not fully tighten.  
No apriete completamente.  
Ne pas viser a fond.

H35251

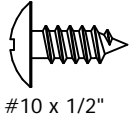

[ 6 ]

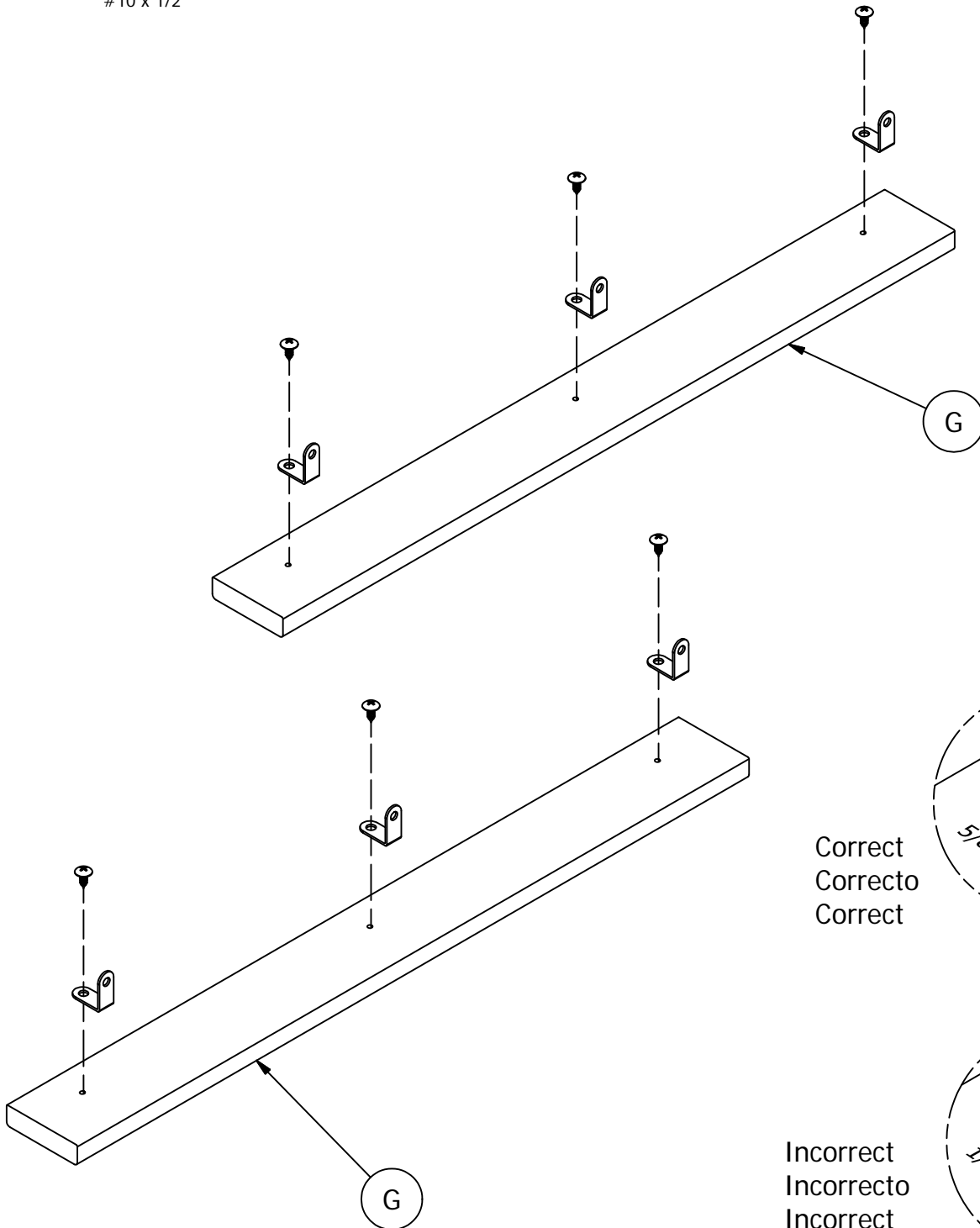

Correct  
Correcto  
Correct

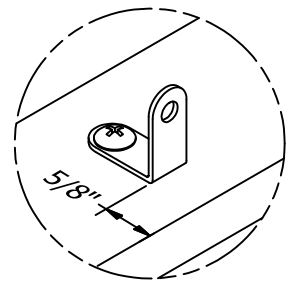

Incorrect  
Incorrecto  
Incorrect

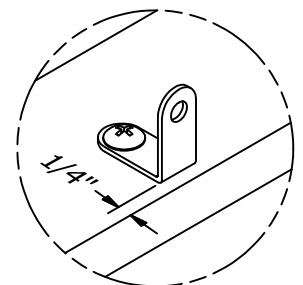

# STEP 5

H38169  [ 4 ]  
Wood Dowel 8 x 30

H23491  [ 2 ]  
#10 x 2"

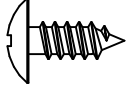
H35251  [ 6 ]  
#10 x 1/2"

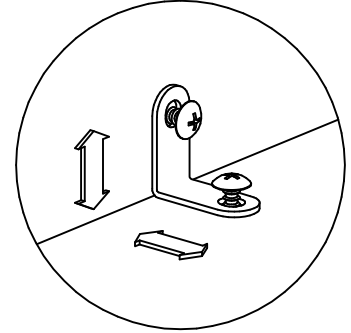

Tighten all screws.  
Apriete todos los tornillos.  
Serrez toutes les vis.

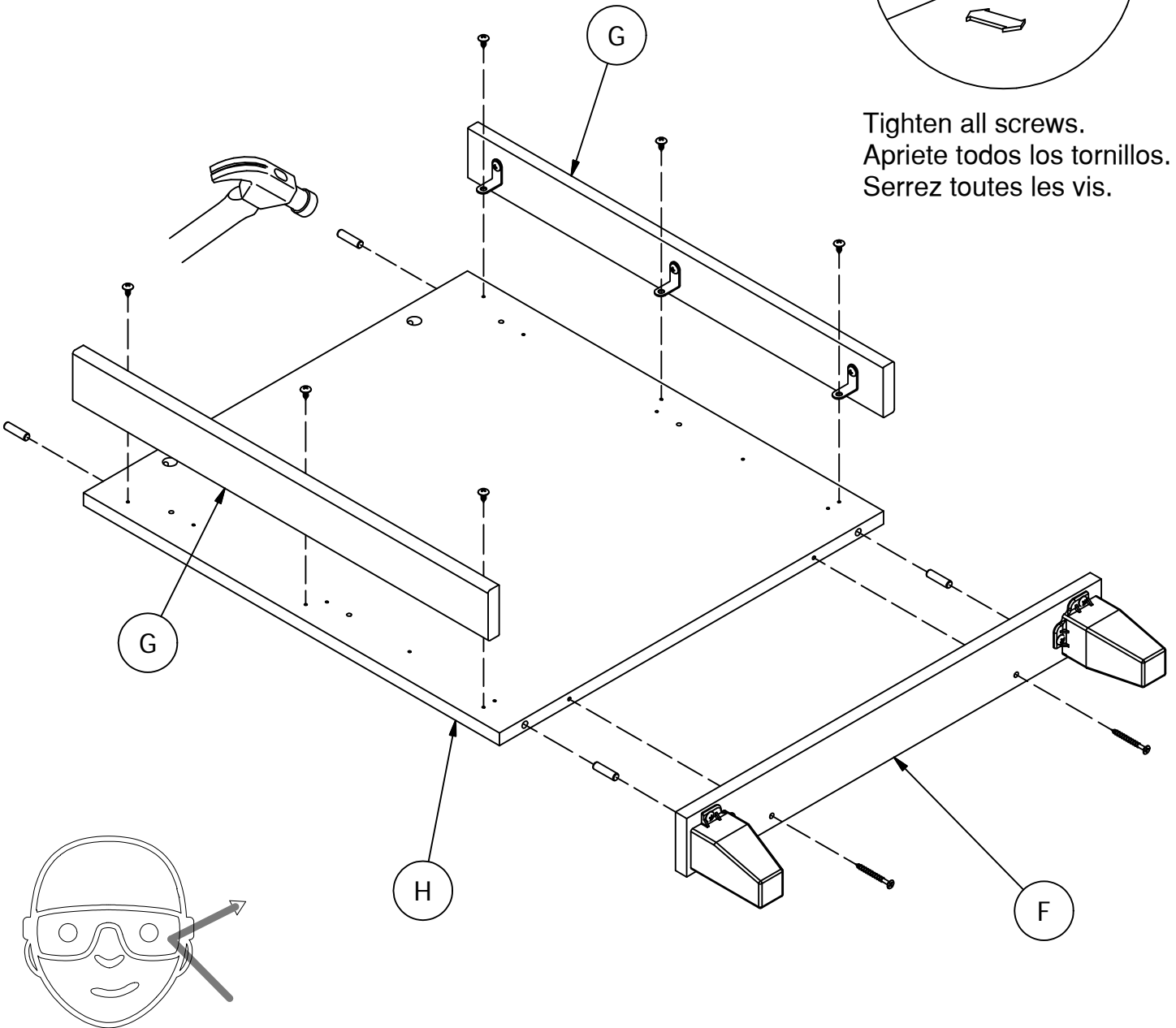

Safety glasses  
Gafas de seguridad  
Lunettes de protection

**STEP 6**

H100445

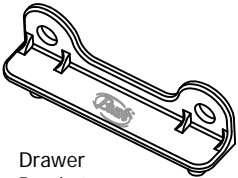

Drawer Bracket

[ 2 ]

H100446

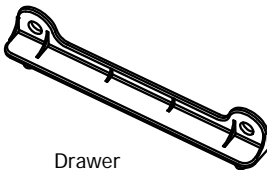

Drawer Bracket

[ 2 ]

H35251

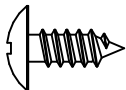

[ 8 ]

#10 x 1/2"

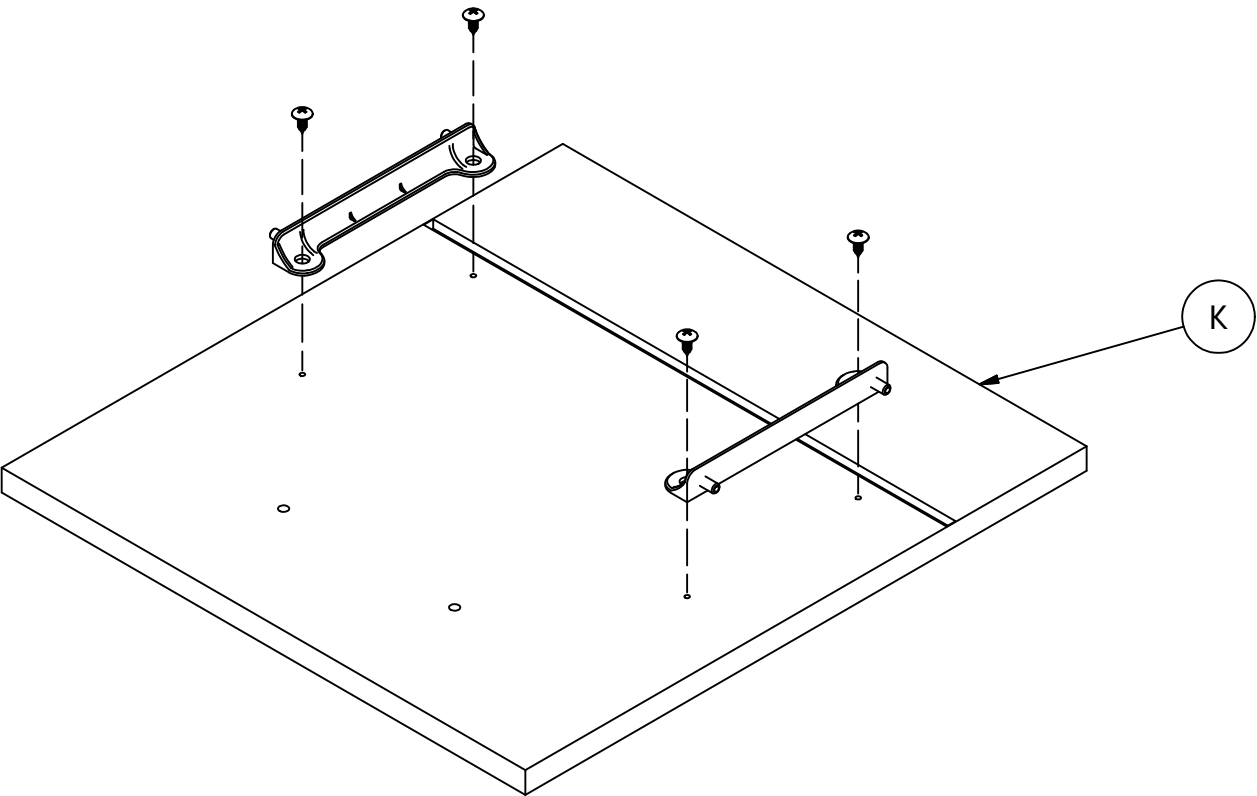
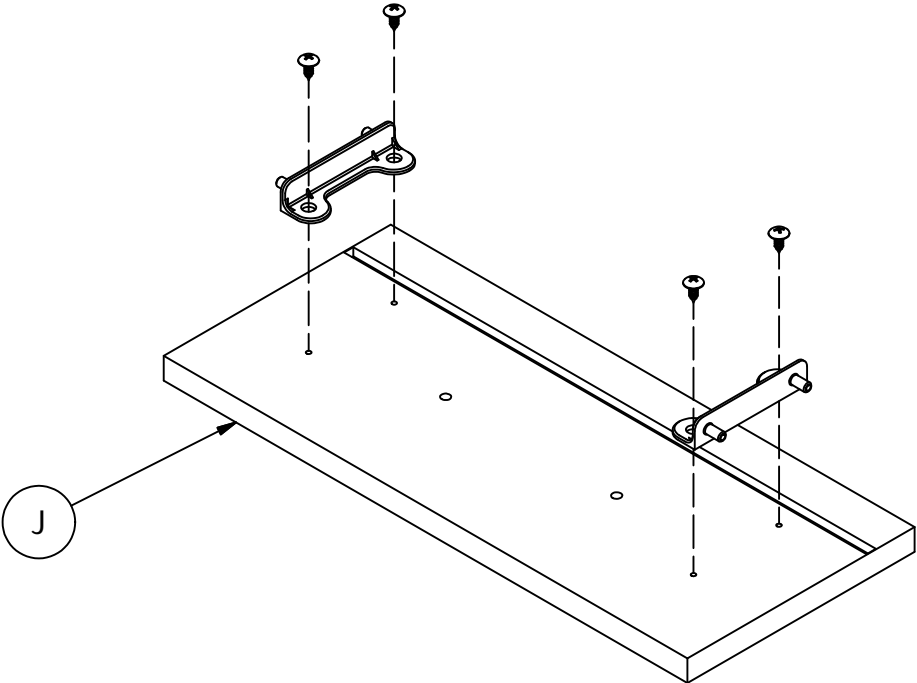

**STEP 7**

H28917

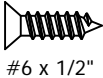

[ 4 ]

#6 x 1/2"

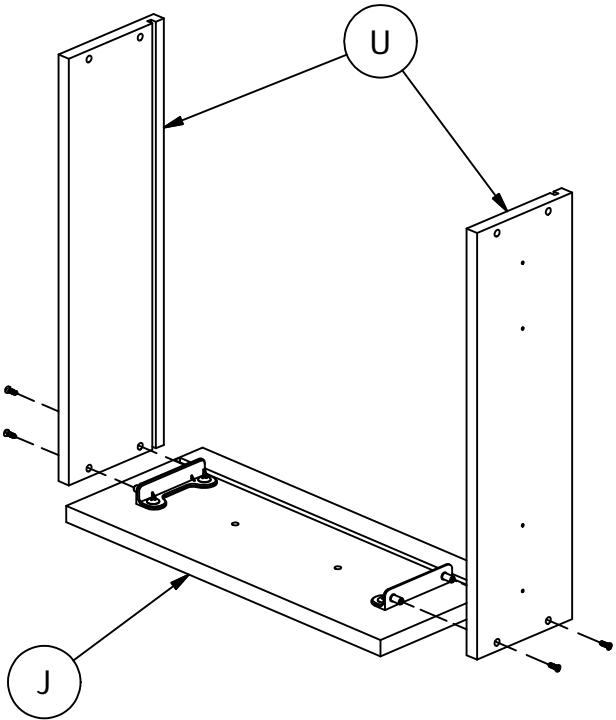

H26053

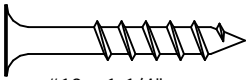

[ 4 ]

#10 x 1-1/4"

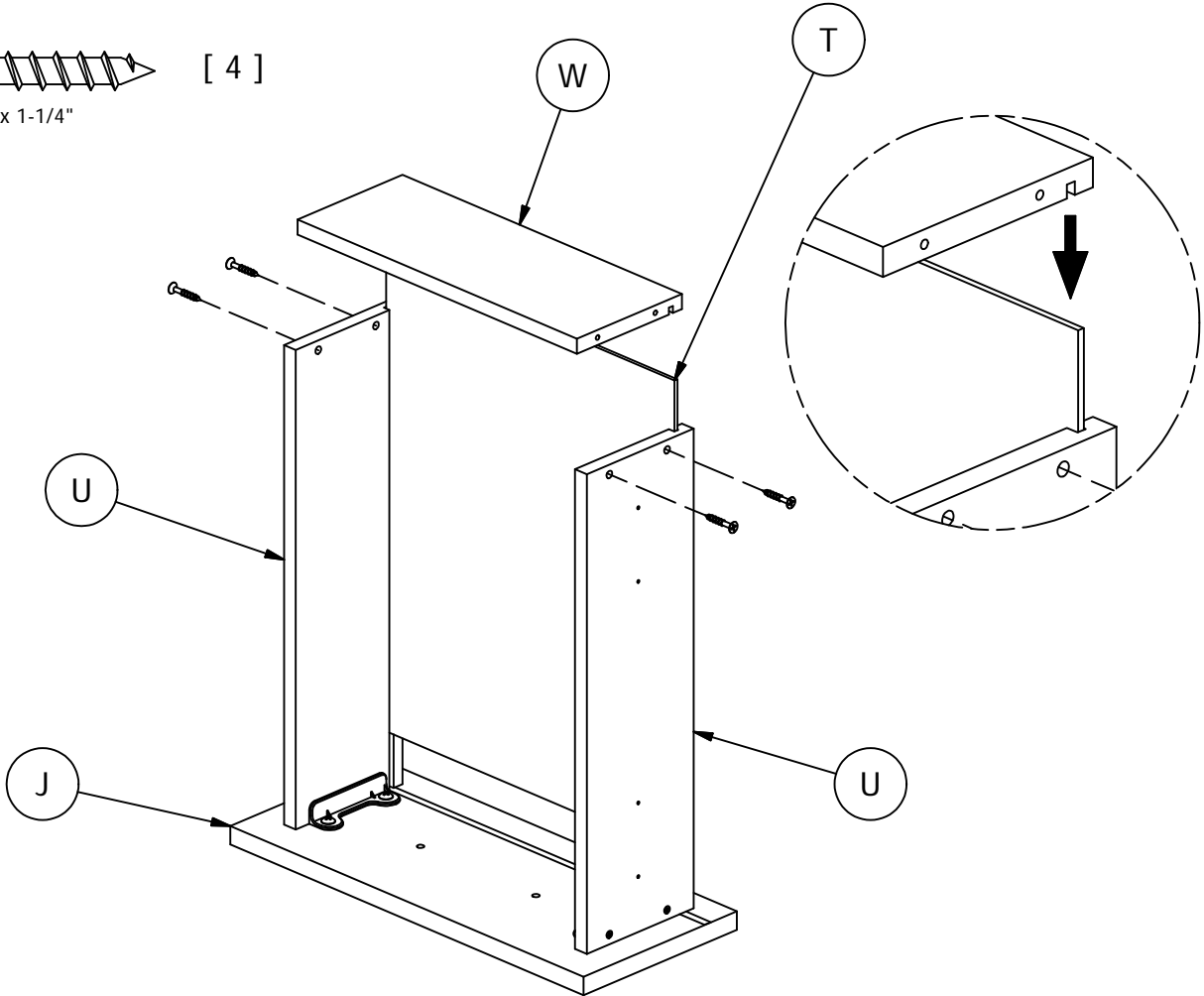

# STEP 8

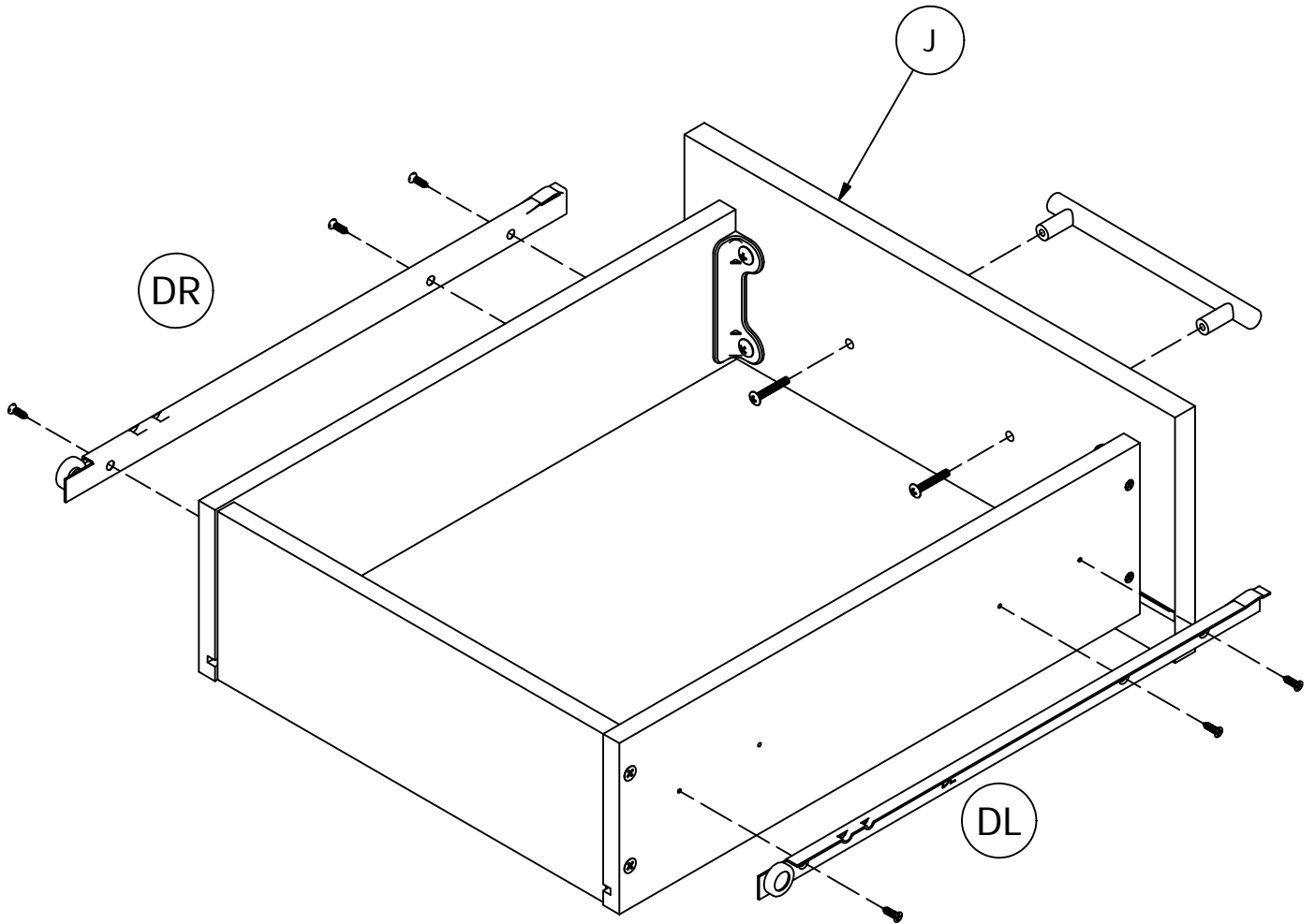
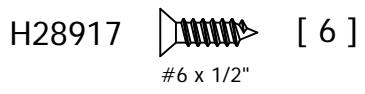
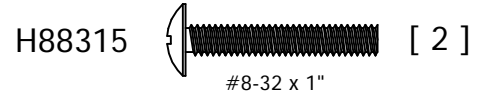
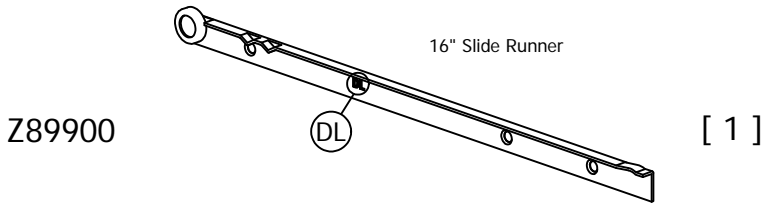
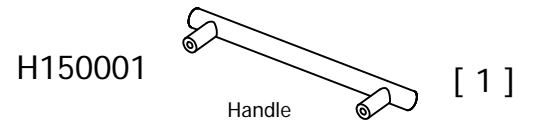
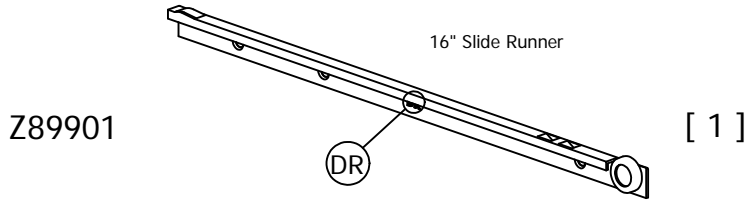

# STEP 9

H101725 [ 4 ]  
#6 x 1/2"

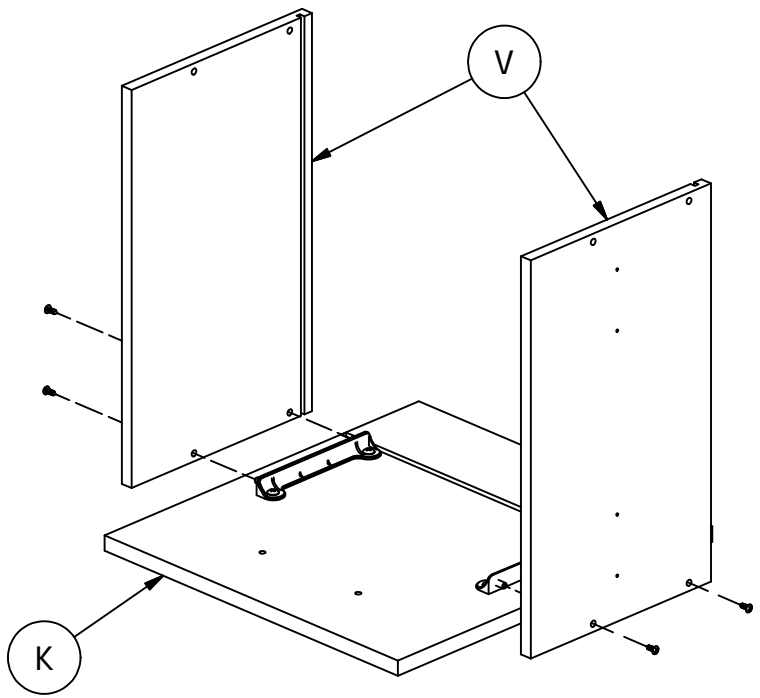

H26053 [ 4 ]  
#10 x 1-1/4"

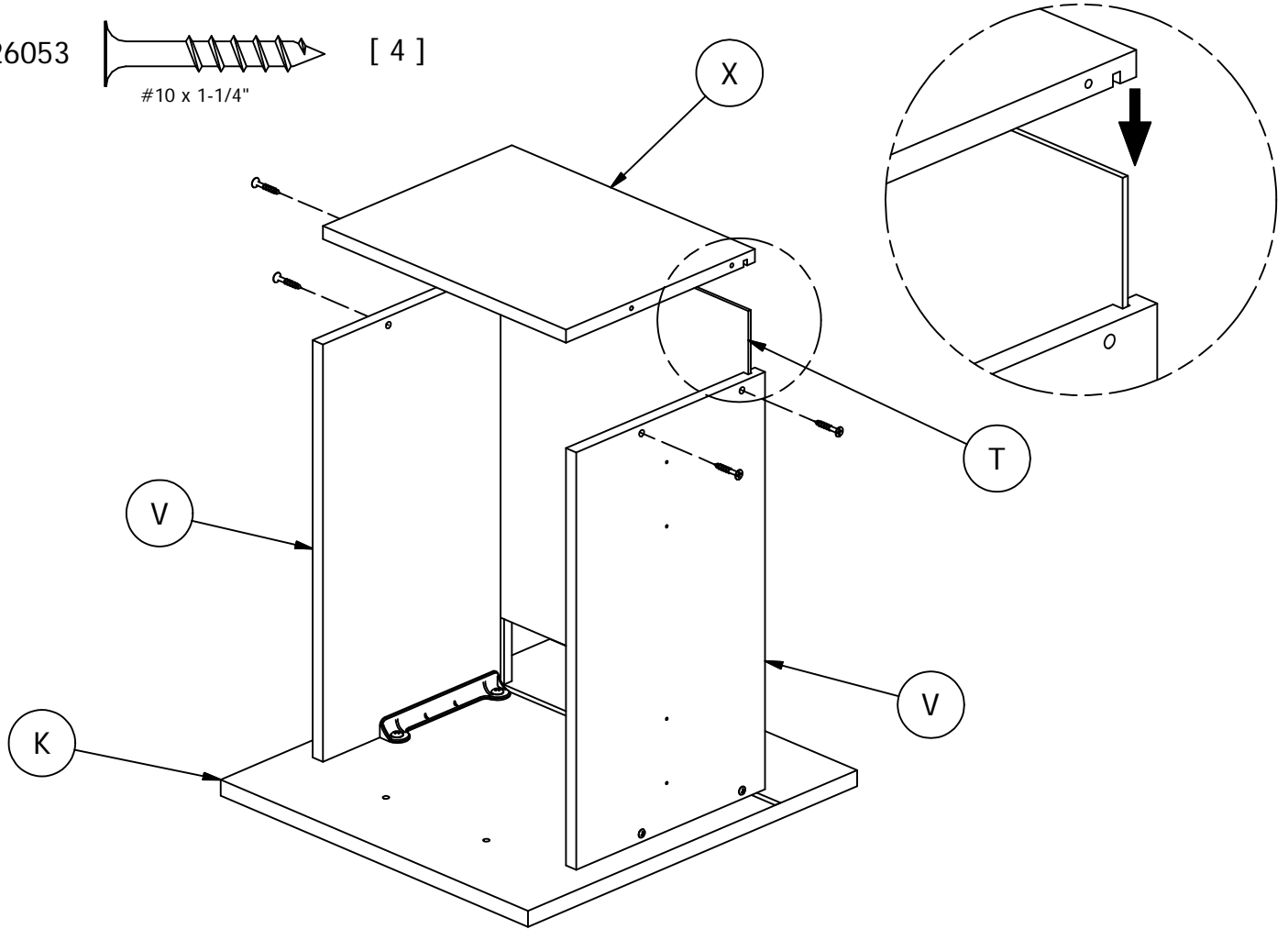

## STEP 10

### Slides Must Be Separated Before Assembly.

Las diapositivas deben separarse antes del montaje.

Les glissières doivent être séparées avant l'assemblage.

Separate and Install

Drawer Slides

### After Separated, Set Aside Until Needed for Assembly.

Después de la separación, déjelo a un lado hasta que sea necesario.

Après la séparation, mettez de côté jusqu'au moment de l'assemblage.

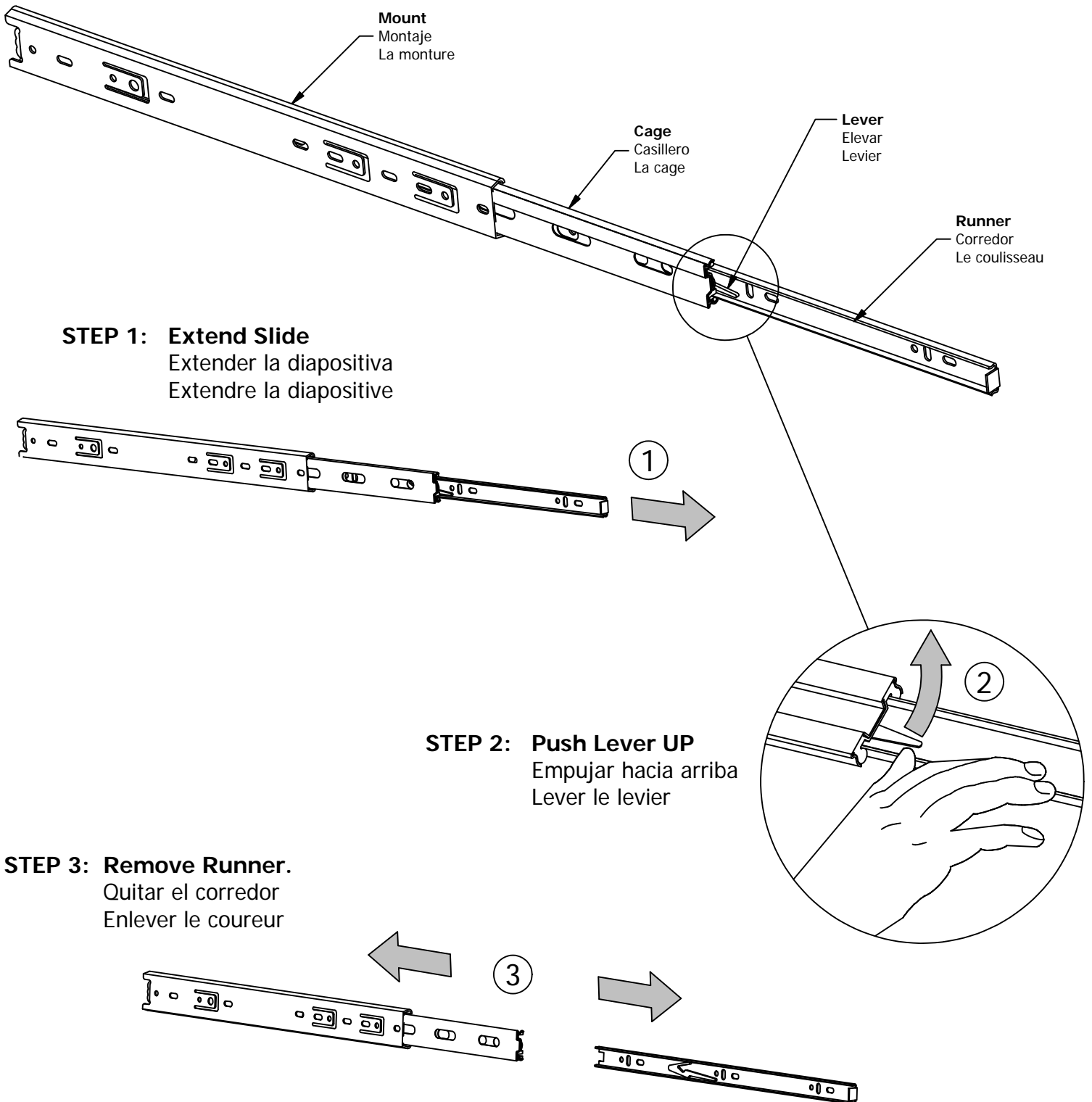

# STEP 11

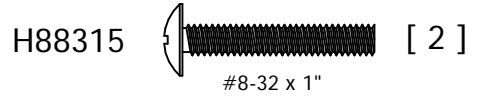
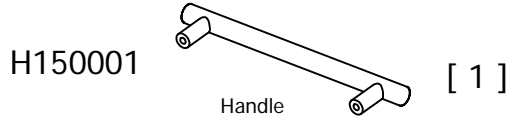
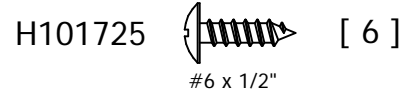
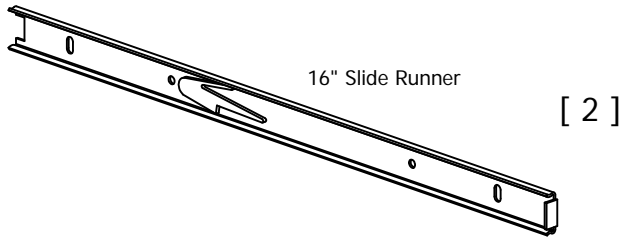

Separate and Install  
Drawer Slides

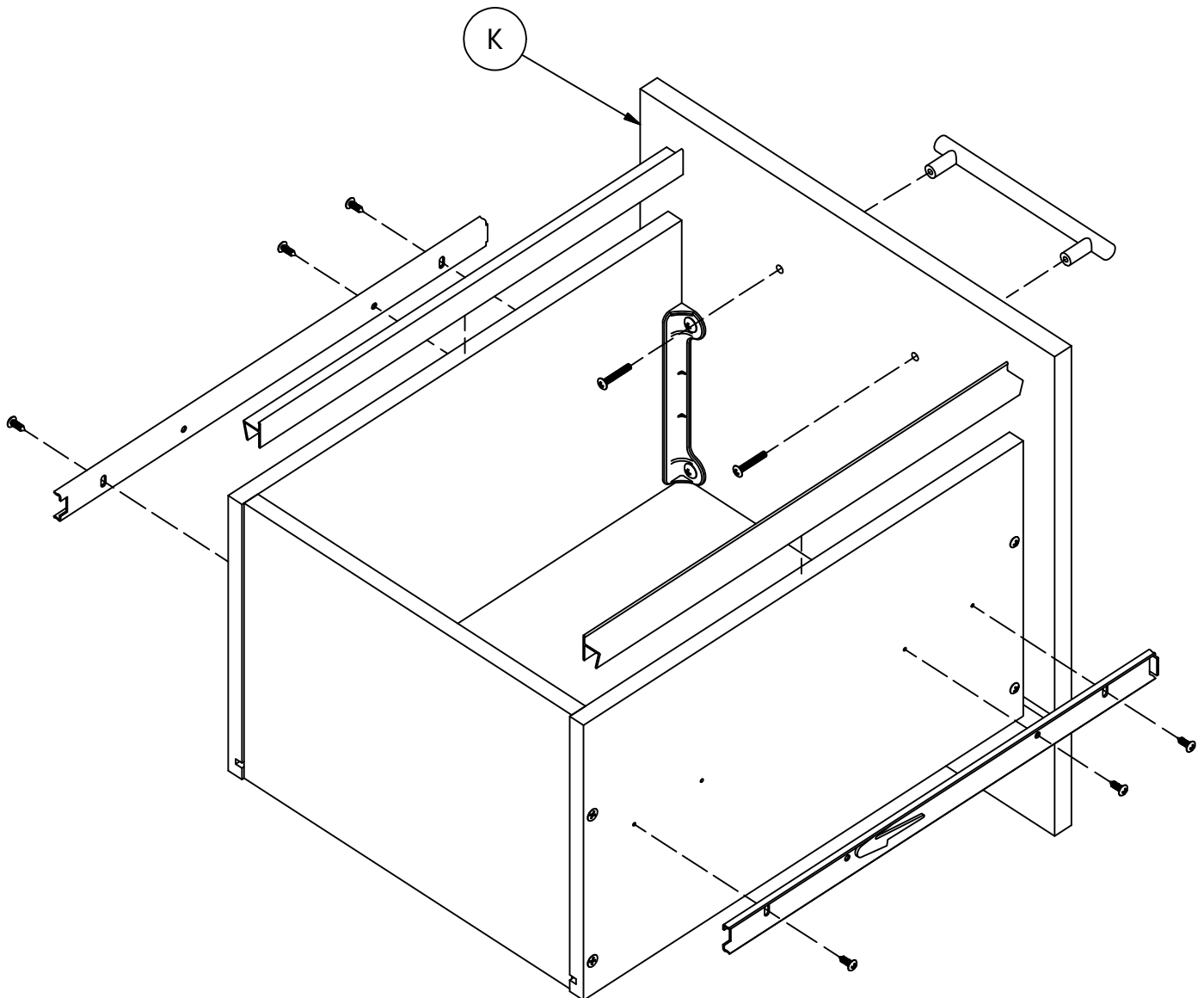
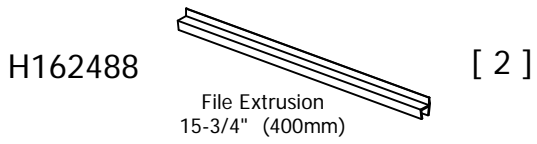

## STEP 12

---

Go to Step 13.  
Proceda al paso 13.  
Allez à l'étape 13.

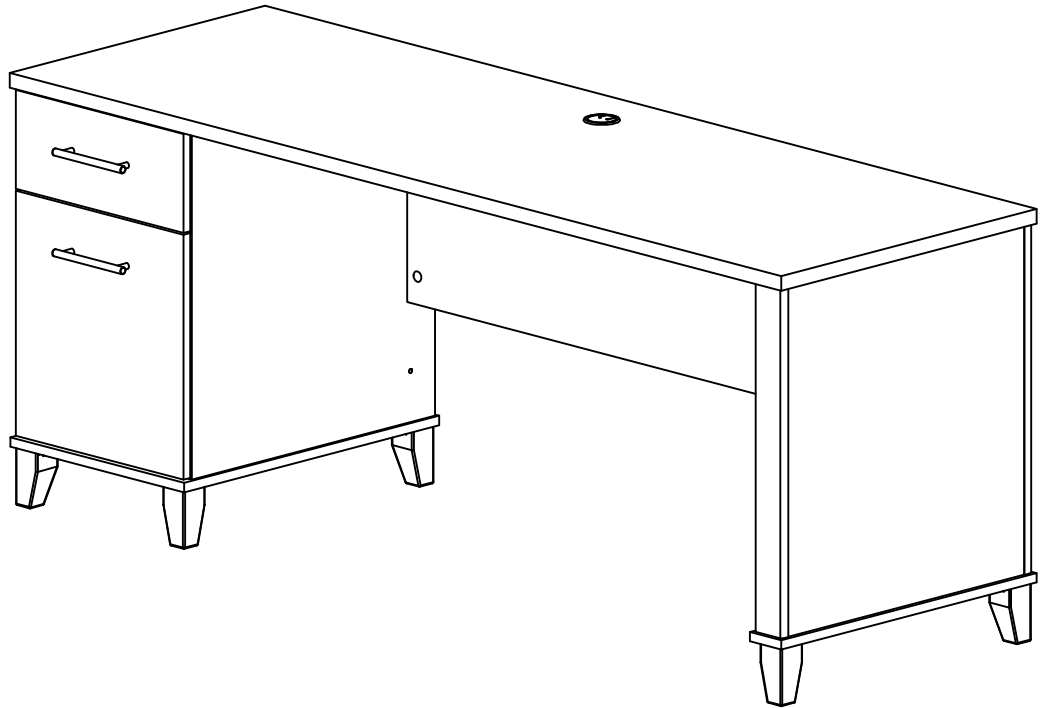

Go to Step 23.  
Proceda al paso 23.  
Allez à l'étape 23.



# STEP 13

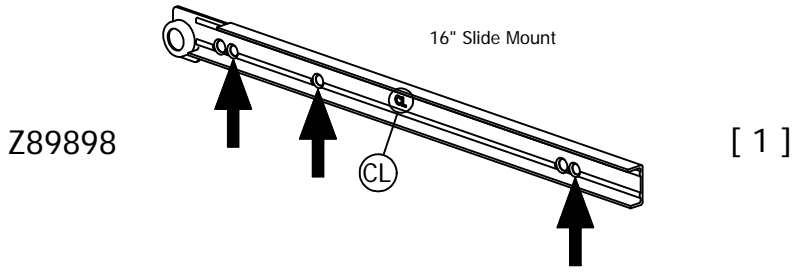

H28917  [ 6 ]  
#6 x 1/2"

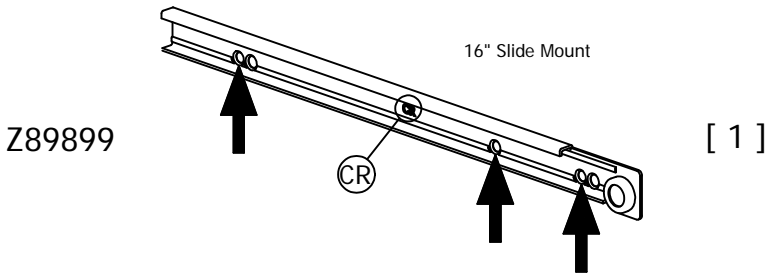

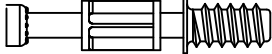
H72988  [ 4 ]  
KD Bolt

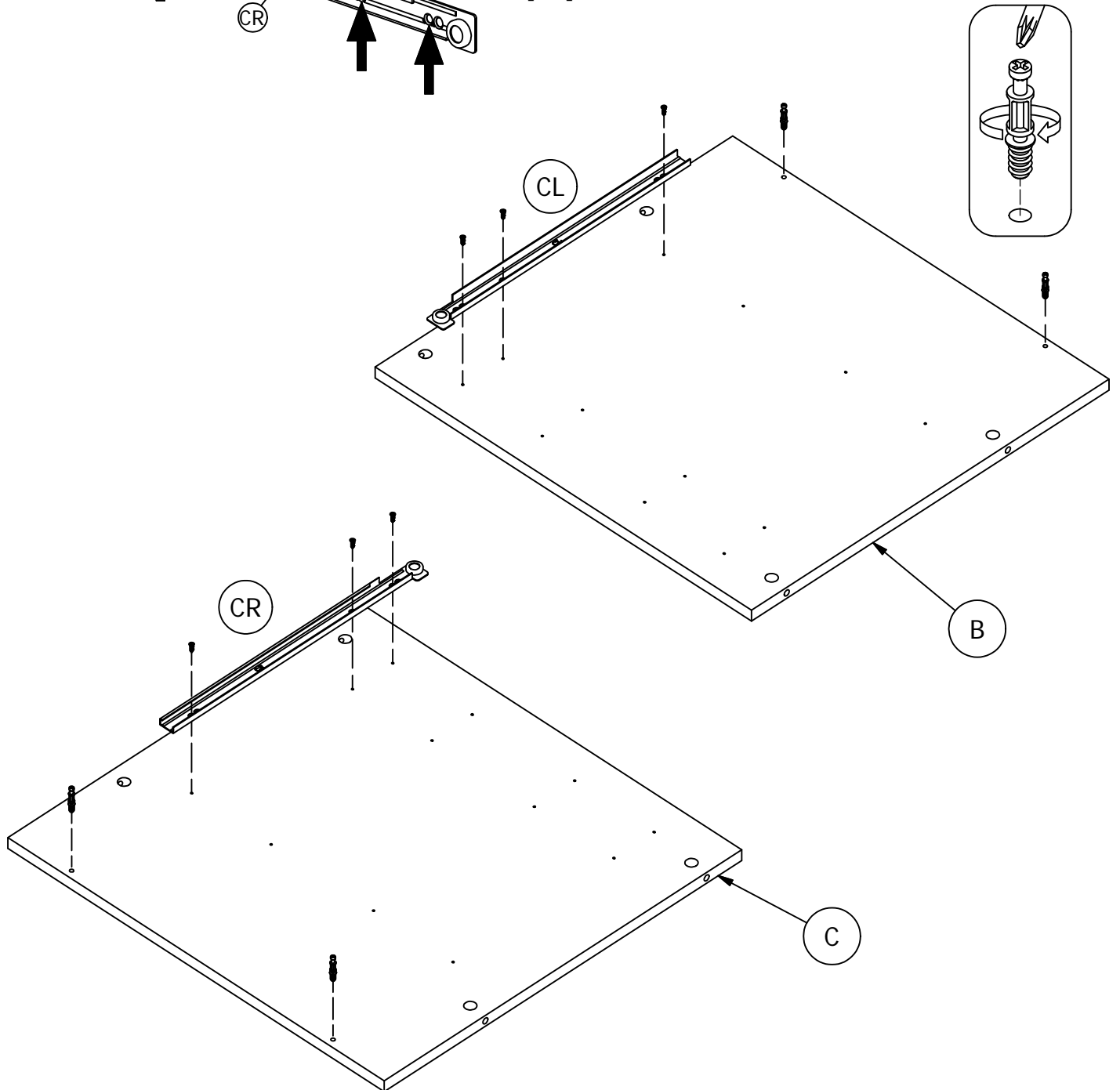

**STEP 14**

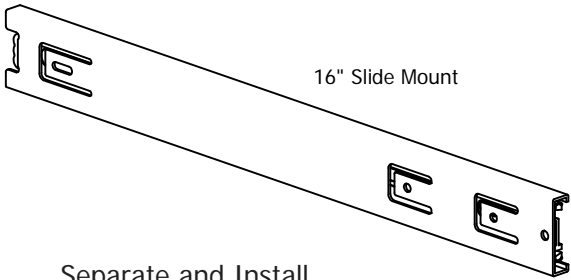

16" Slide Mount

[ 1 ]

H101725



[ 3 ]

#6 x 1/2"

Separate and Install  
Drawer Slides

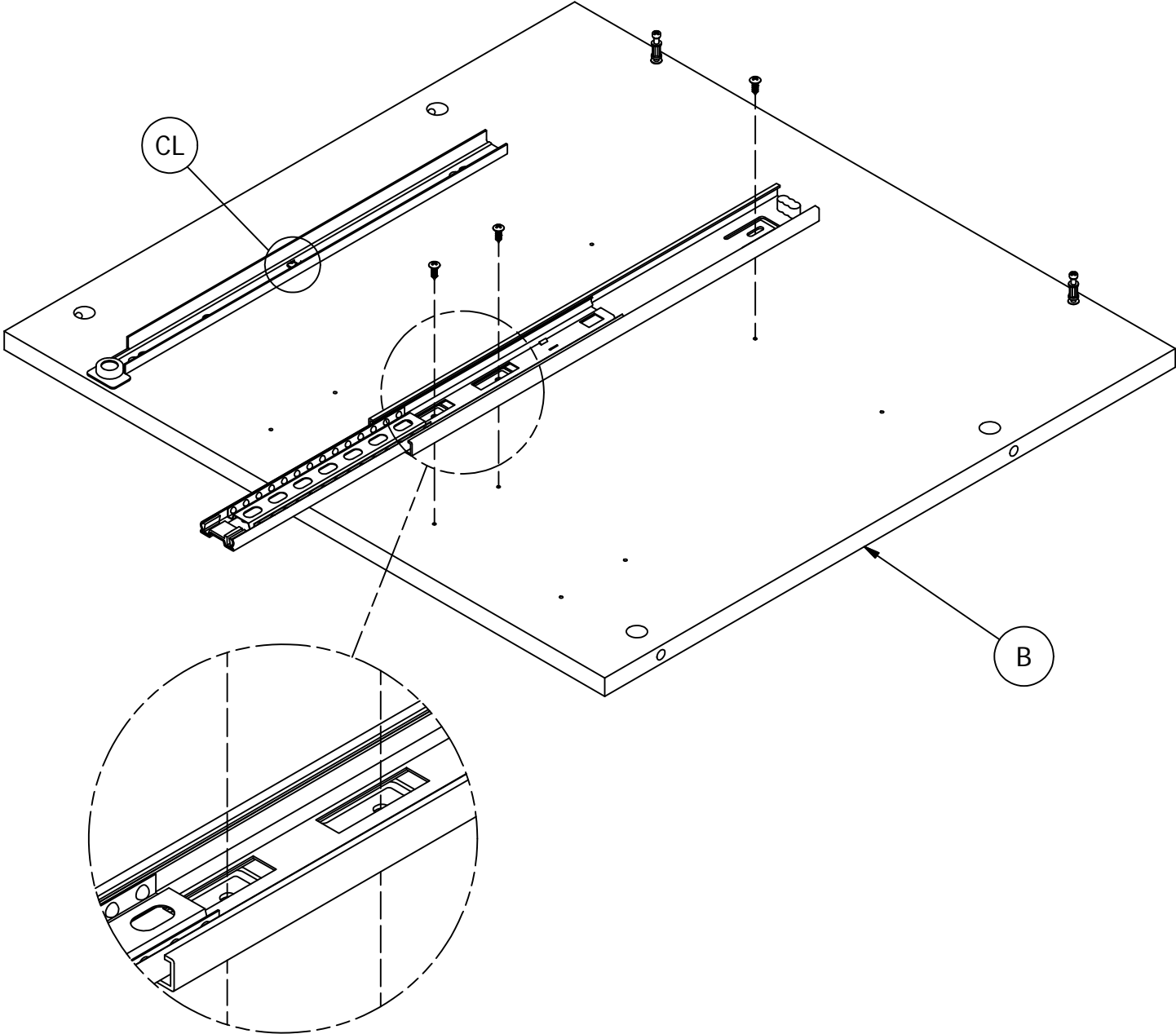

# STEP 15

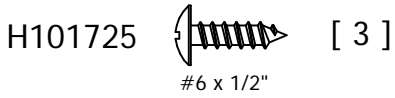
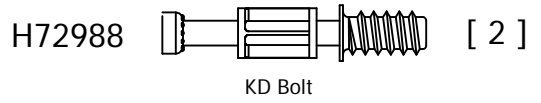
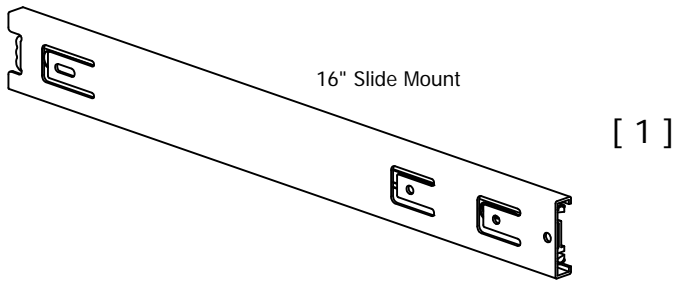

Separate and Install  
Drawer Slides

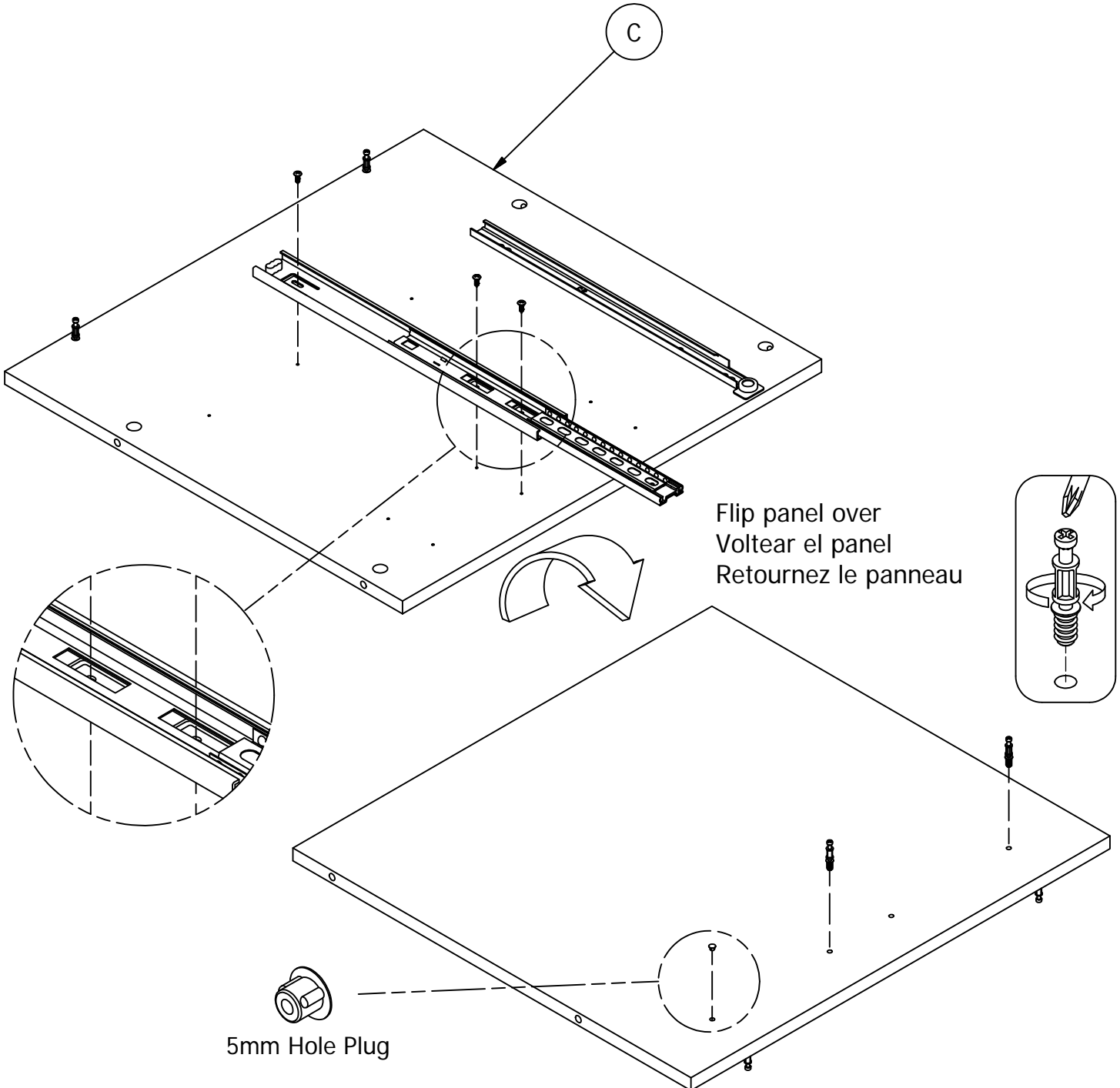

**STEP 16**

H71659

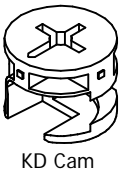

[ 4 ]

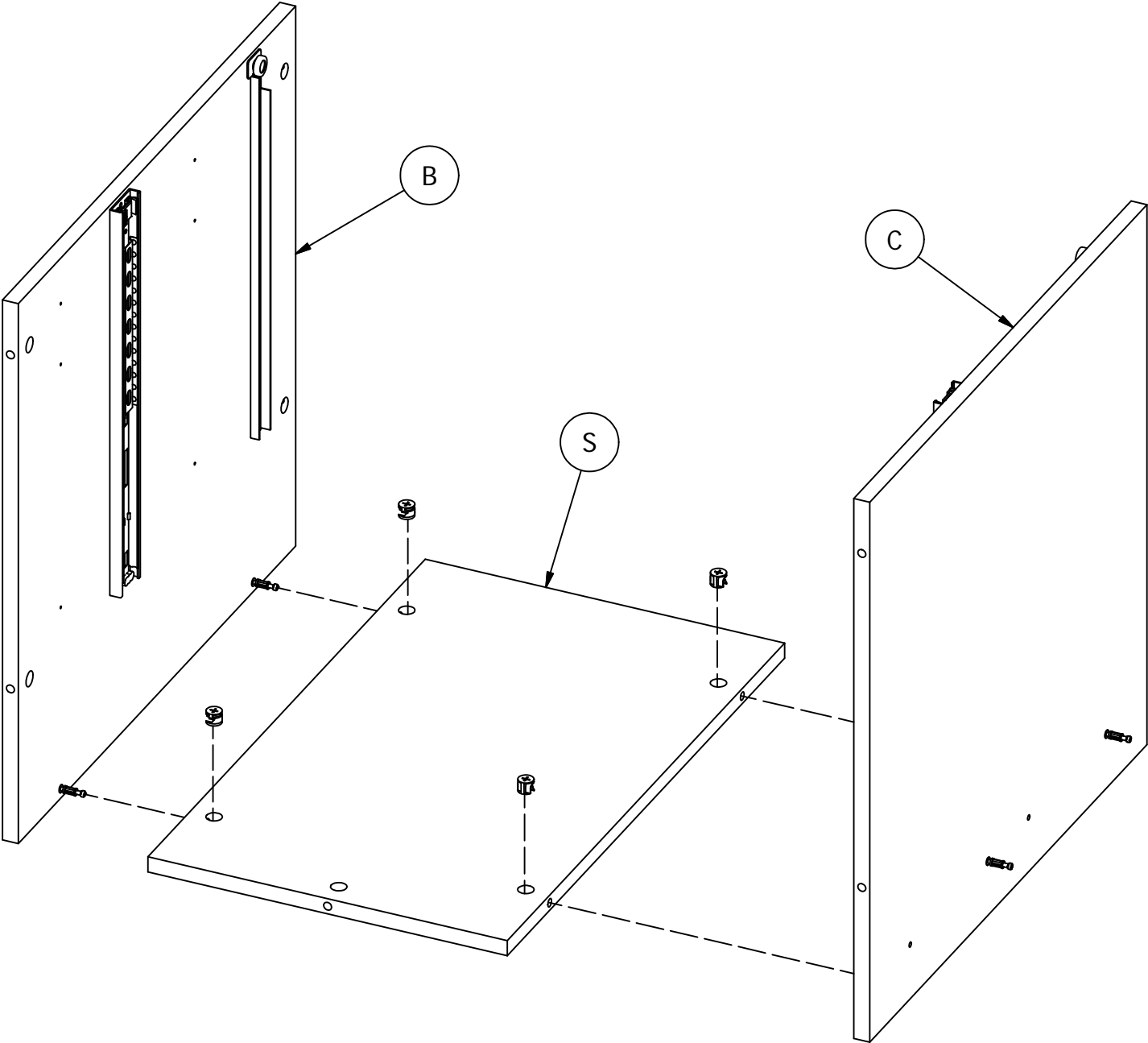
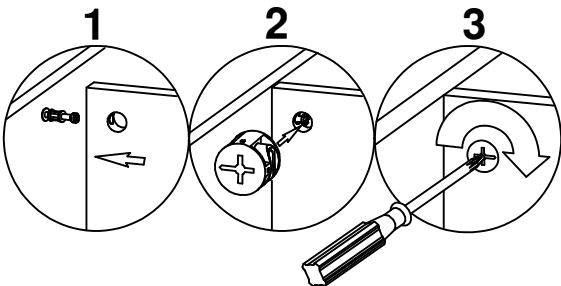

**STEP 17**

H71659

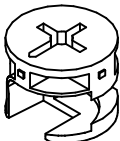

KD Cam

[ 5 ]

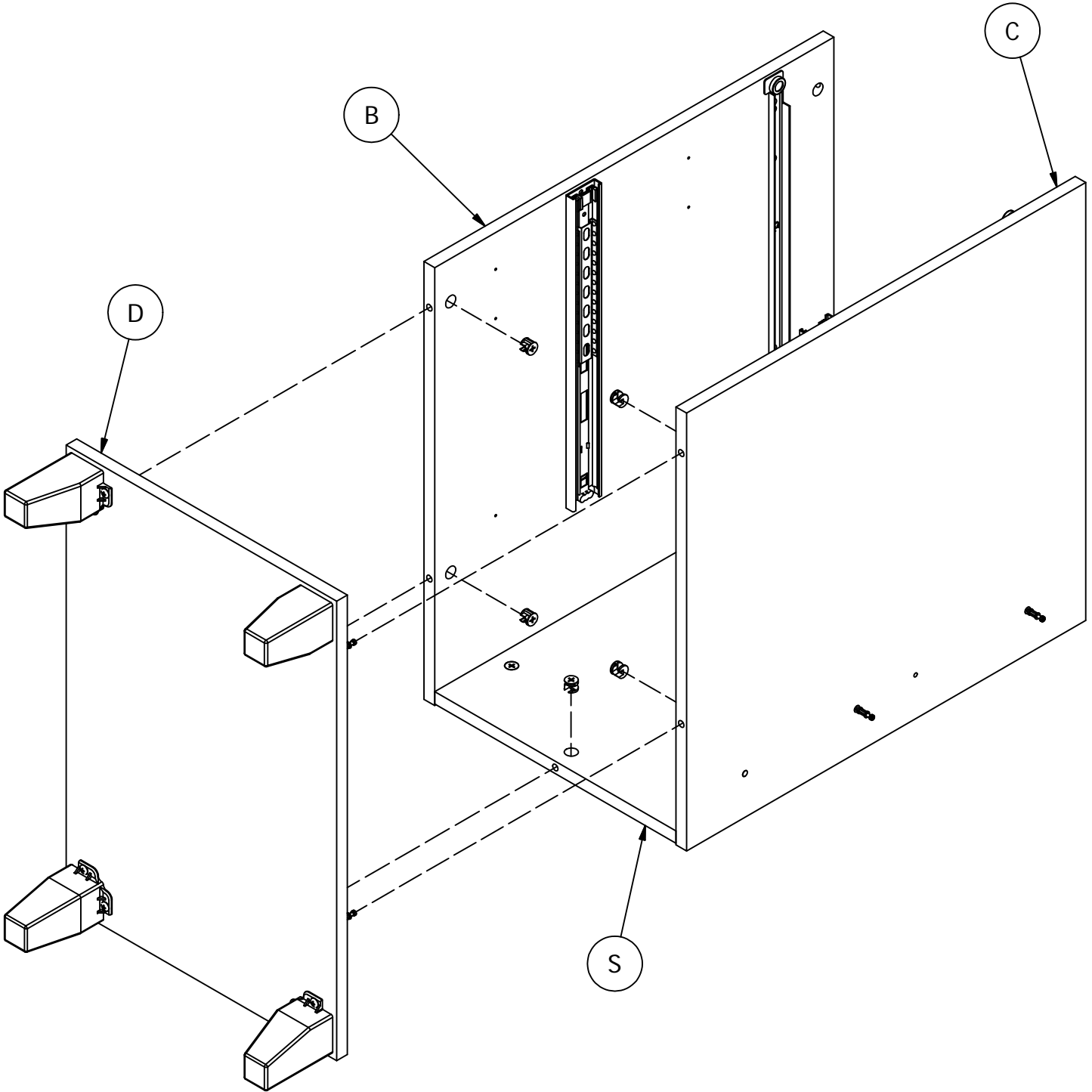
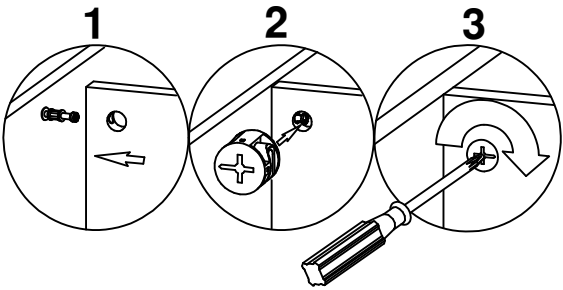

**STEP 18**

H72988 [ 2 ]  
KD Bolt

[ 2 ]  
5mm Hole Plug

[ 6 ]  
3mm Hole Plug

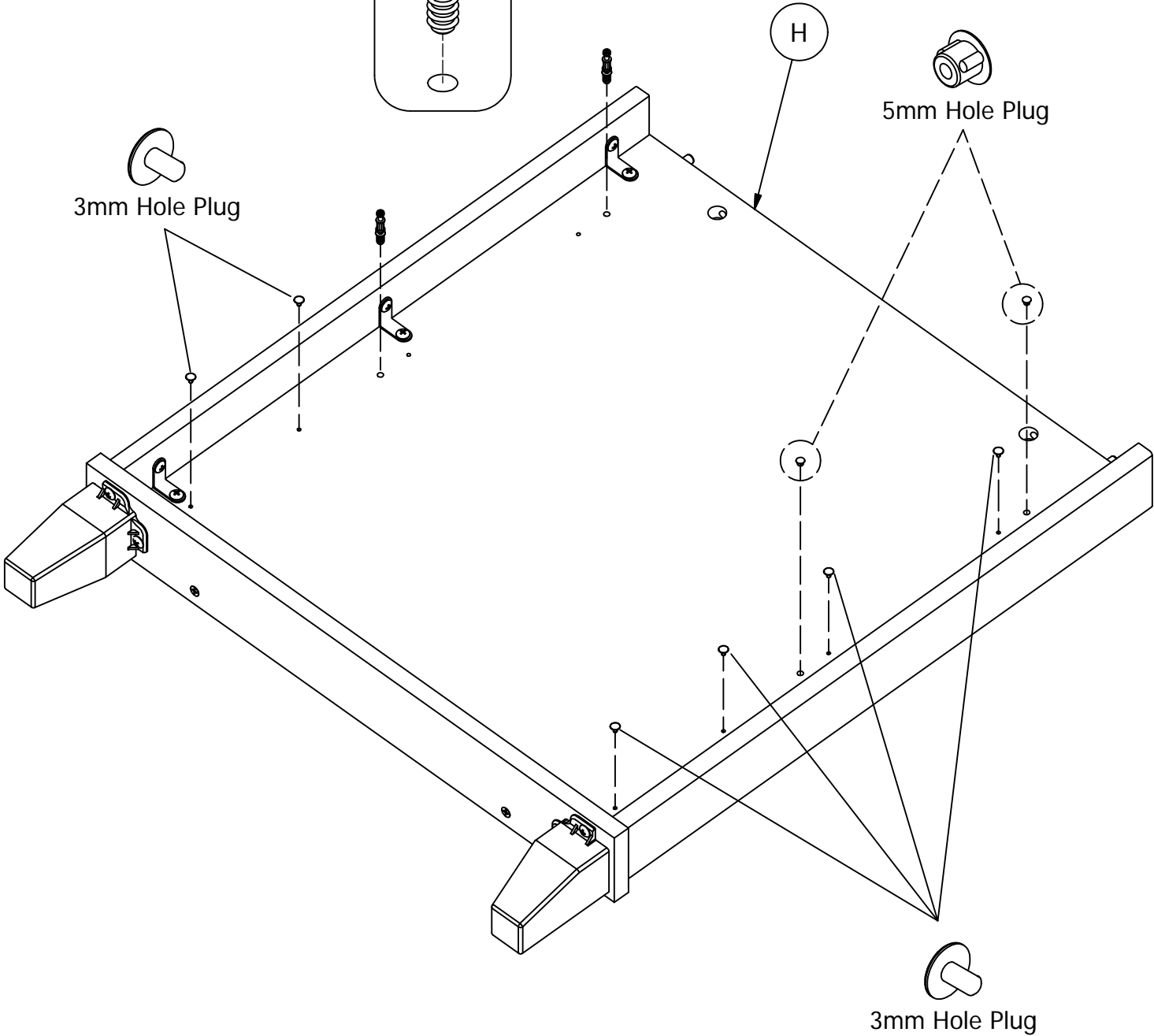
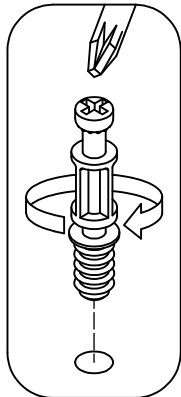

# STEP 19

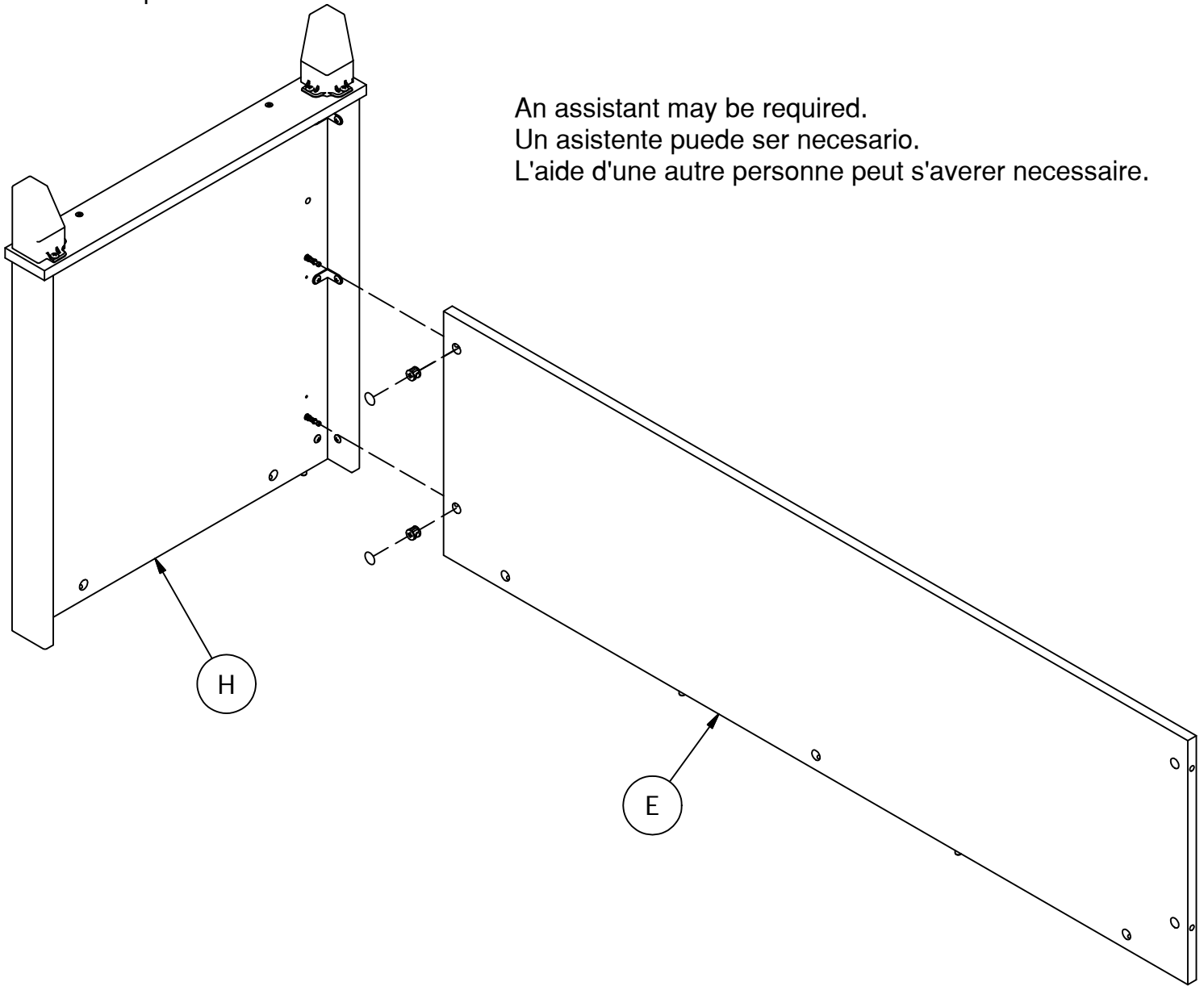
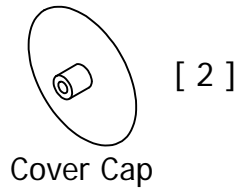
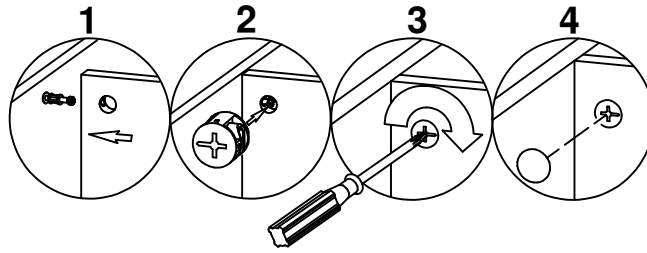
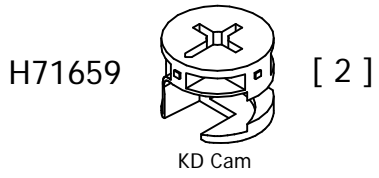

# STEP 20

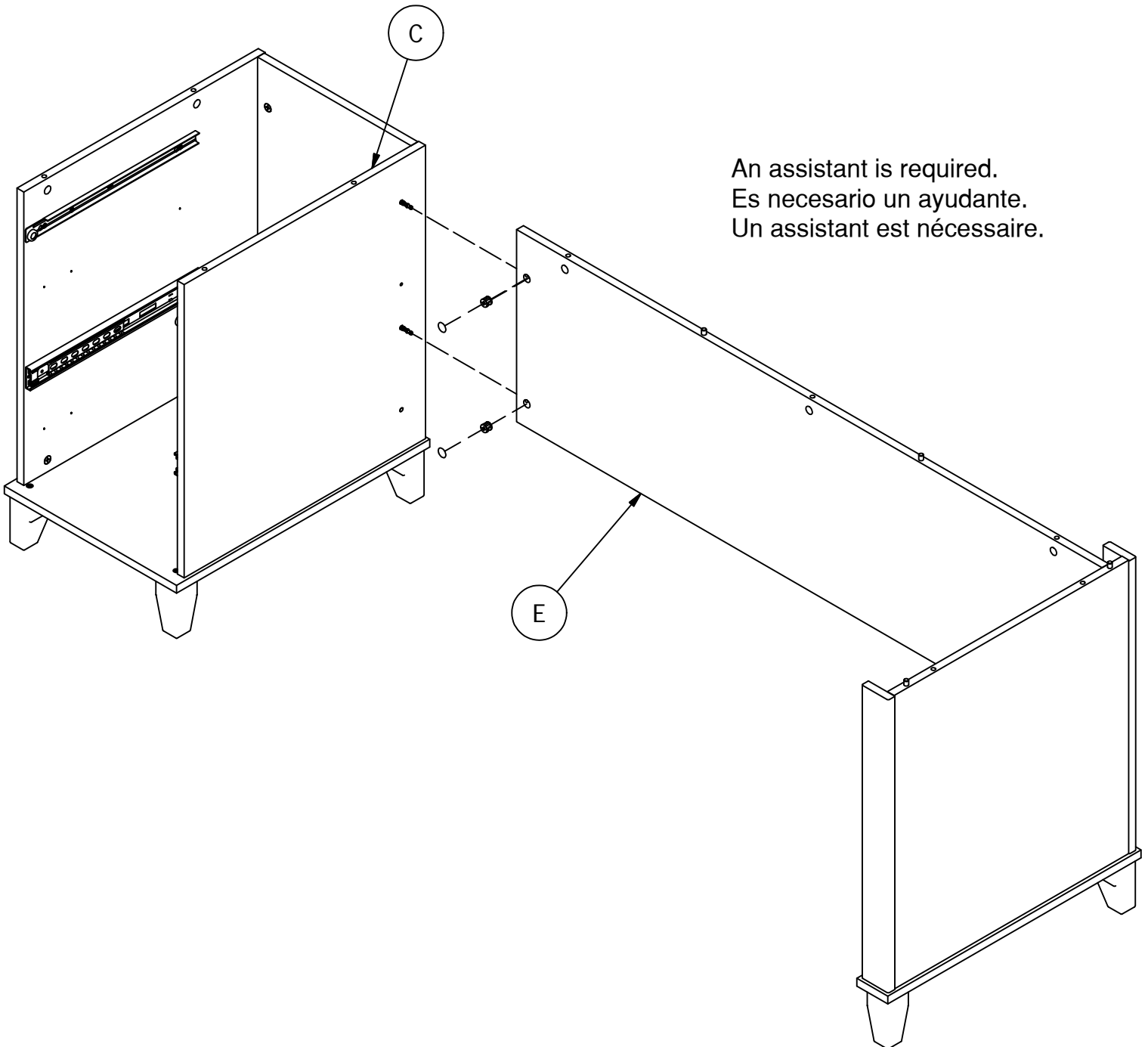
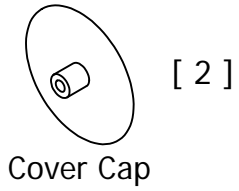
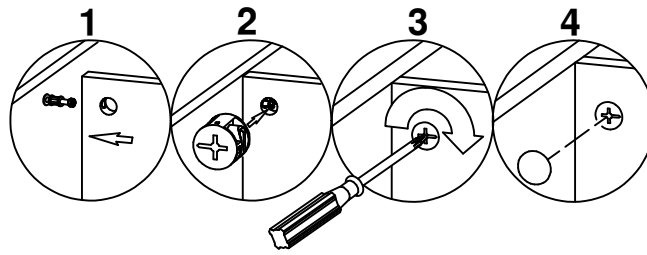
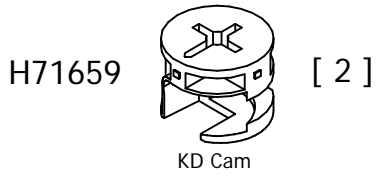

An assistant is required.  
Es necesario un ayudante.  
Un assistant est nécessaire.

**STEP 21**

H72988

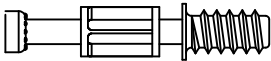

KD Bolt

[ 9 ]

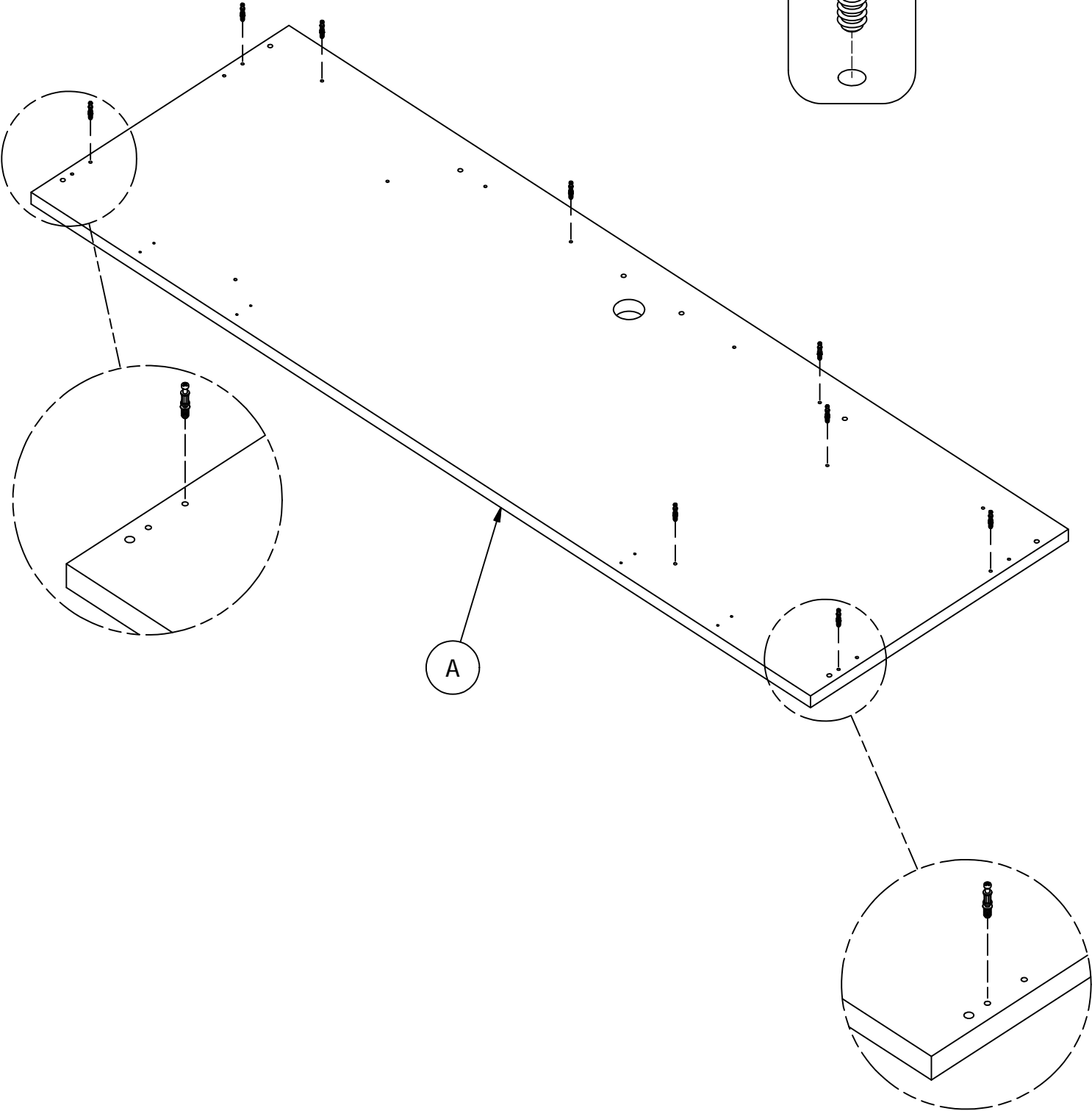
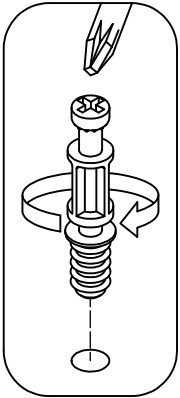

## STEP 22

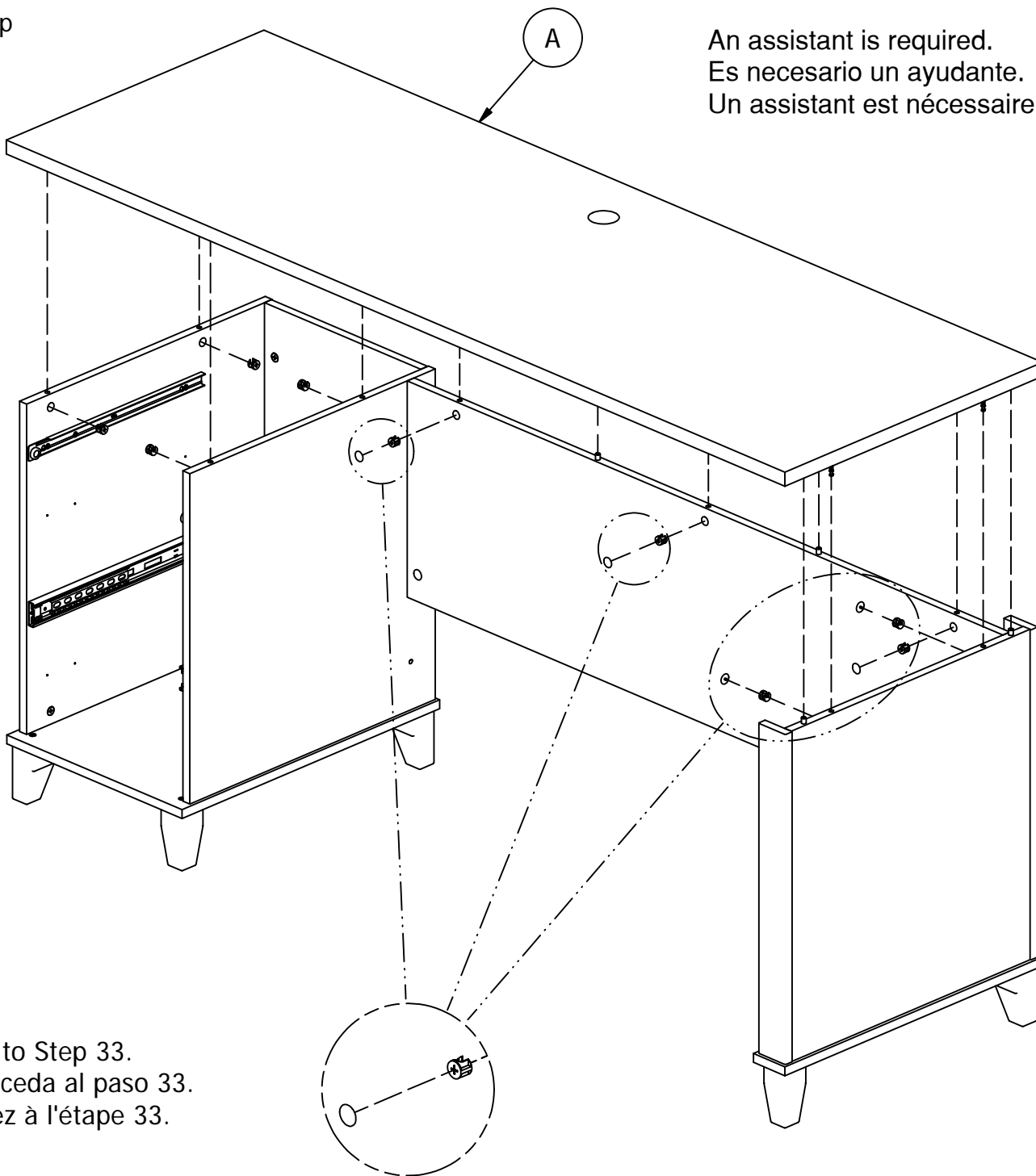
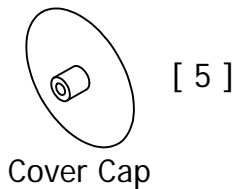
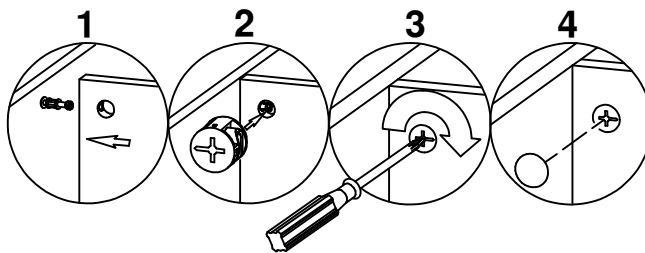
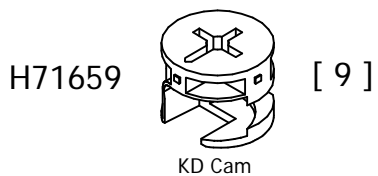

An assistant is required.  
Es necesario un ayudante.  
Un assistant est nécessaire.

Go to Step 33.  
Proceda al paso 33.  
Allez à l'étape 33.

# STEP 23

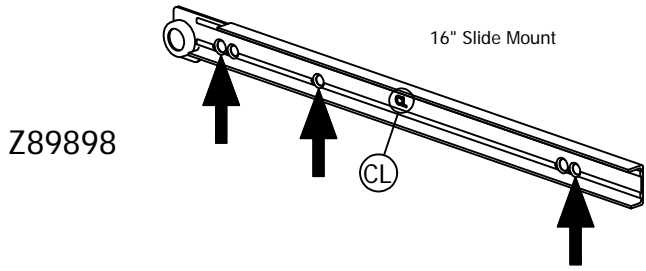

[ 1 ]

H28917

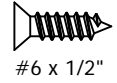

[ 6 ]

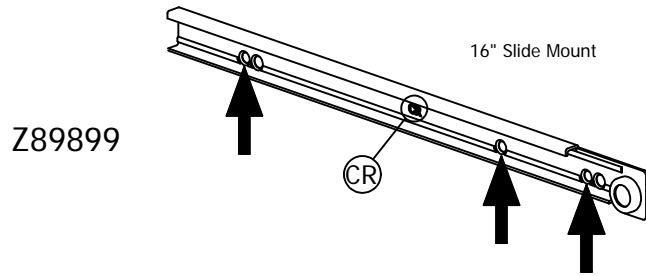

[ 1 ]

H72988

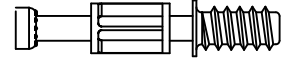

[ 4 ]

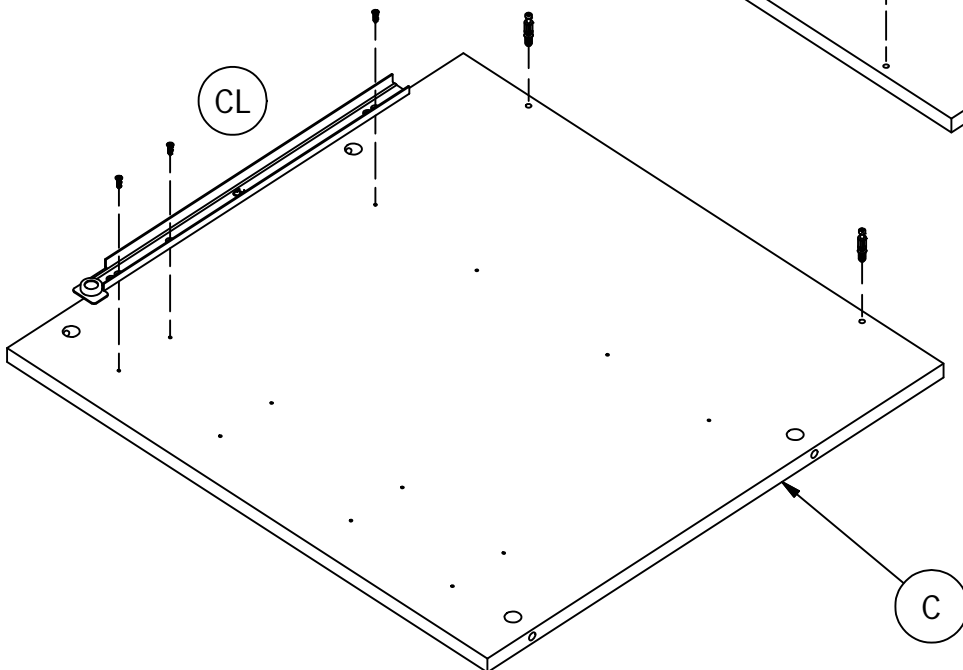
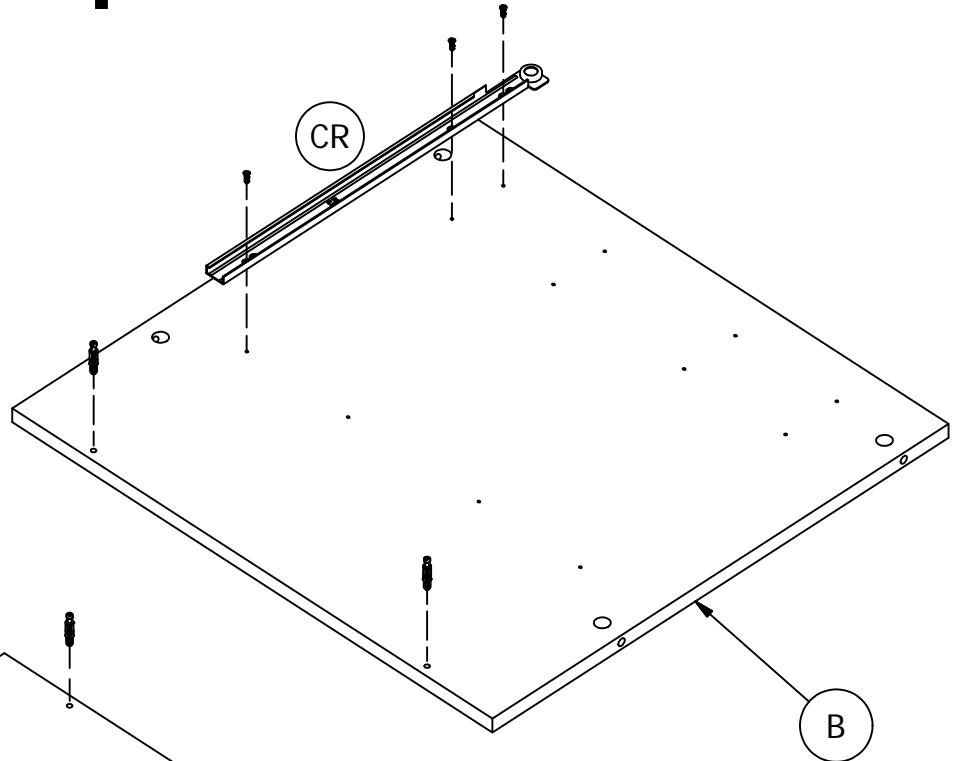
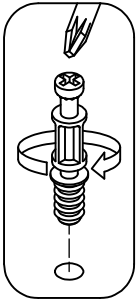

**STEP 24**

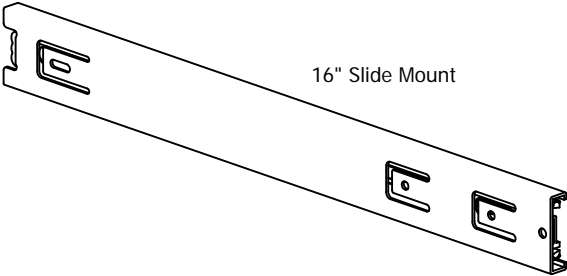

16" Slide Mount

[ 1 ]

H101725

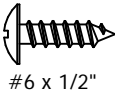

[ 3 ]

#6 x 1/2"

Separate and Install  
Drawer Slides

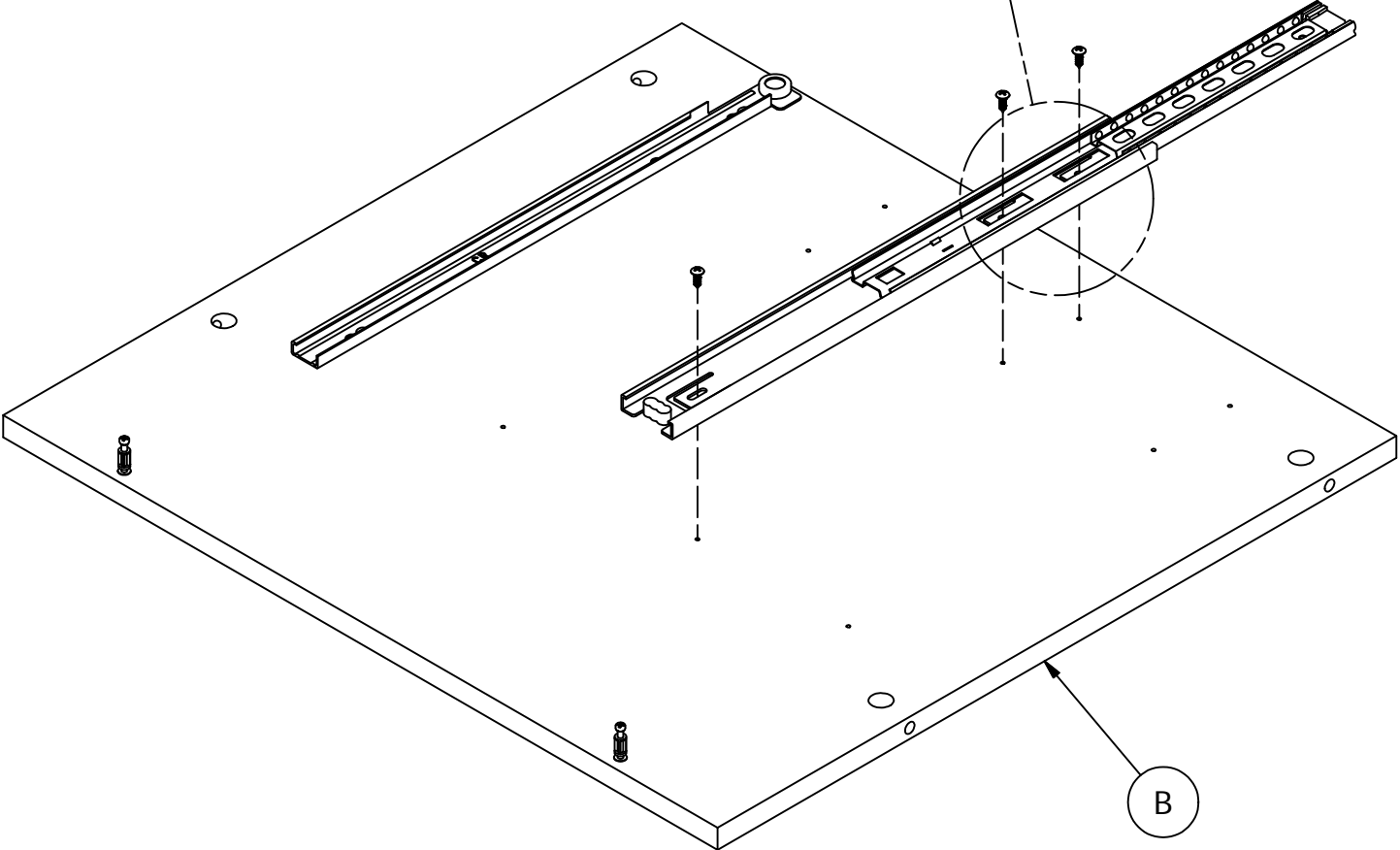
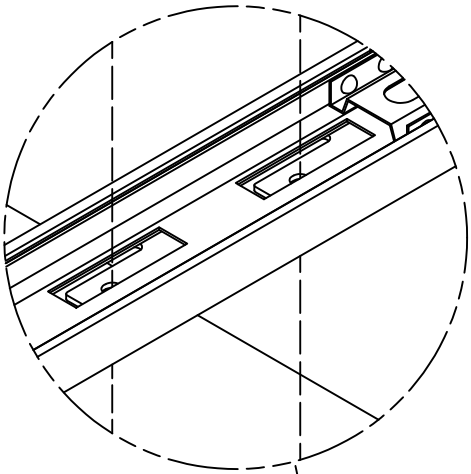

B

# STEP 25

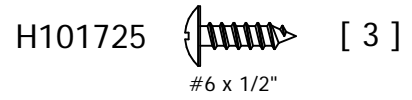
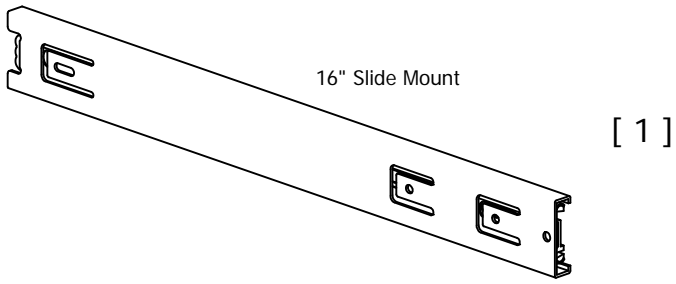

Separate and Install  
Drawer Slides

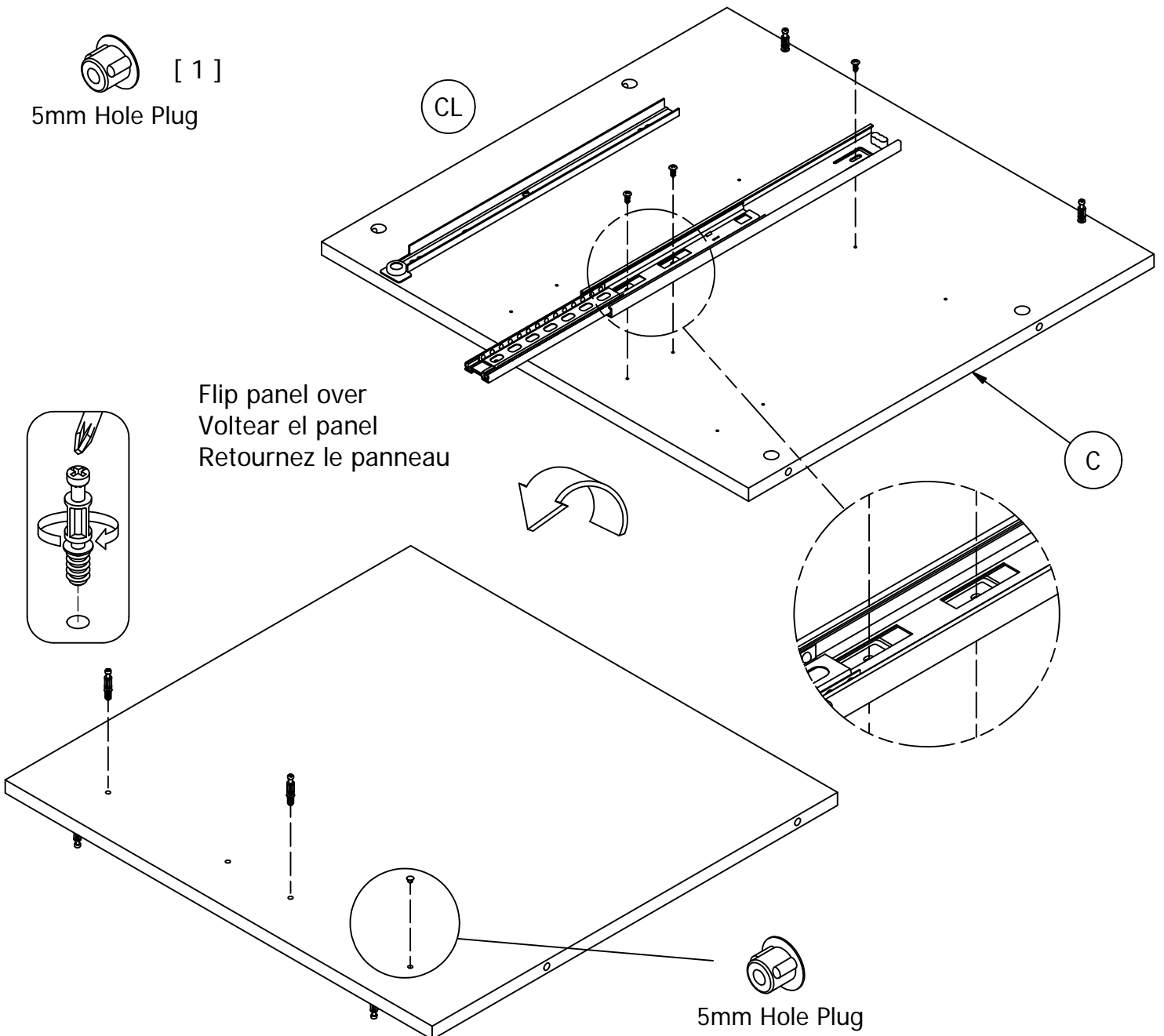
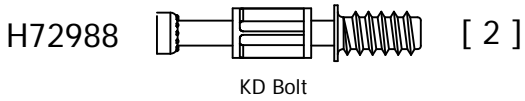

**STEP 26**

H71659

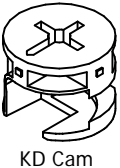

[ 4 ]

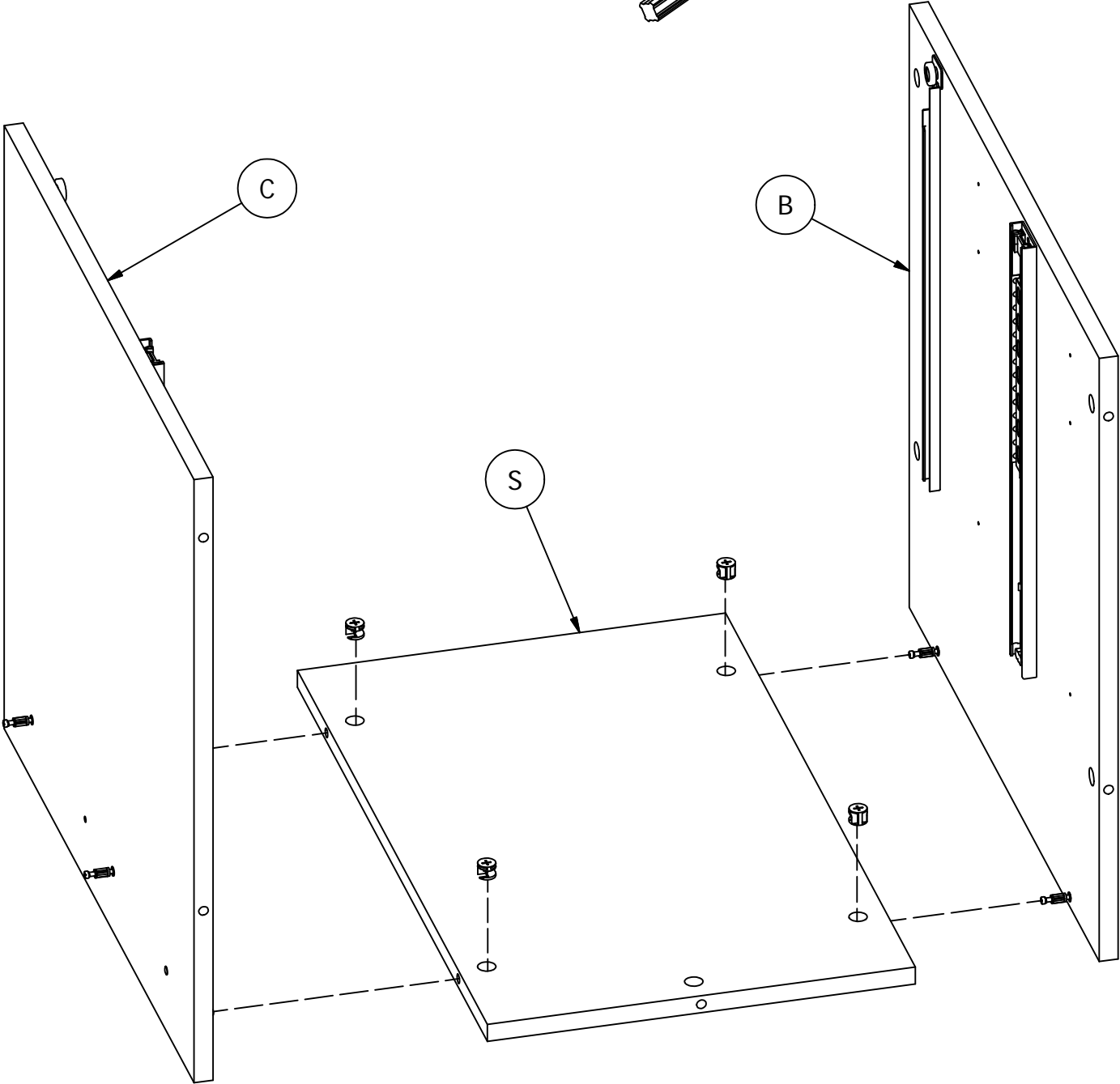
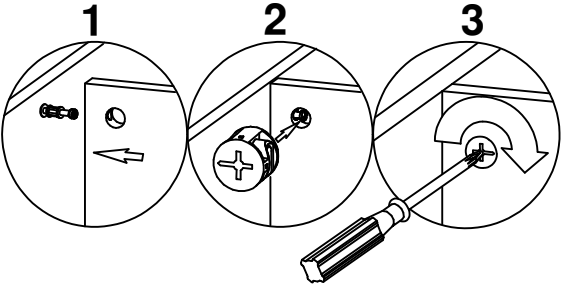

**STEP 27**

H71659

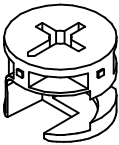

KD Cam

[ 5 ]

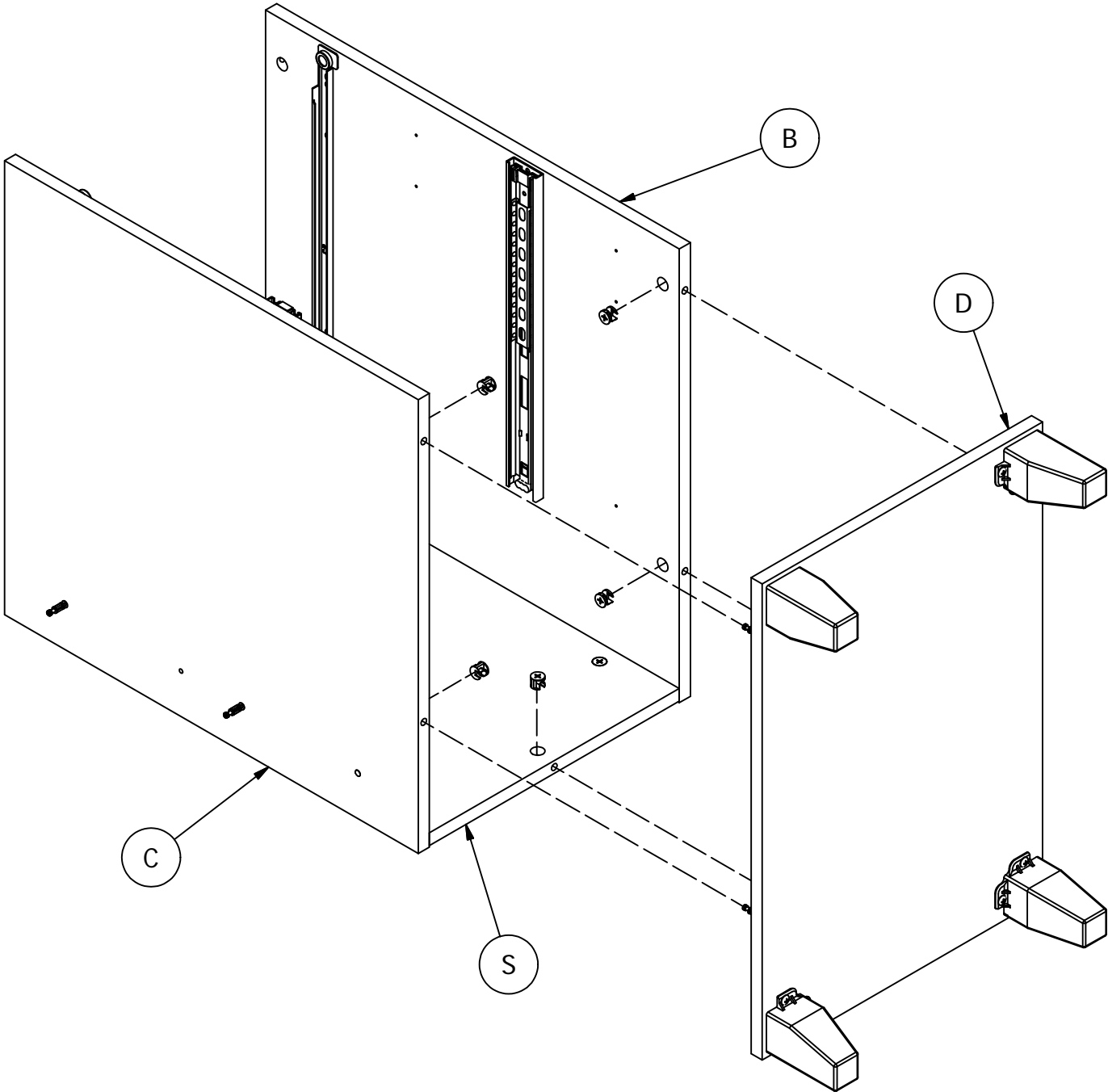
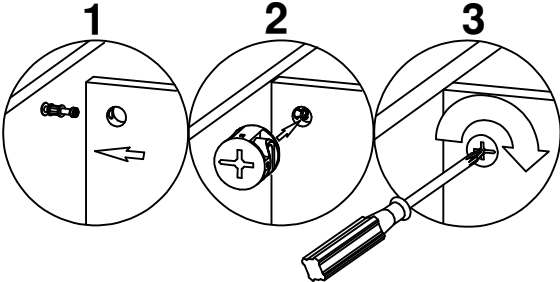

# STEP 28

H72988 [ 2 ]  
KD Bolt

[ 6 ]  
3mm Hole Plug

[ 2 ]  
5mm Hole Plug

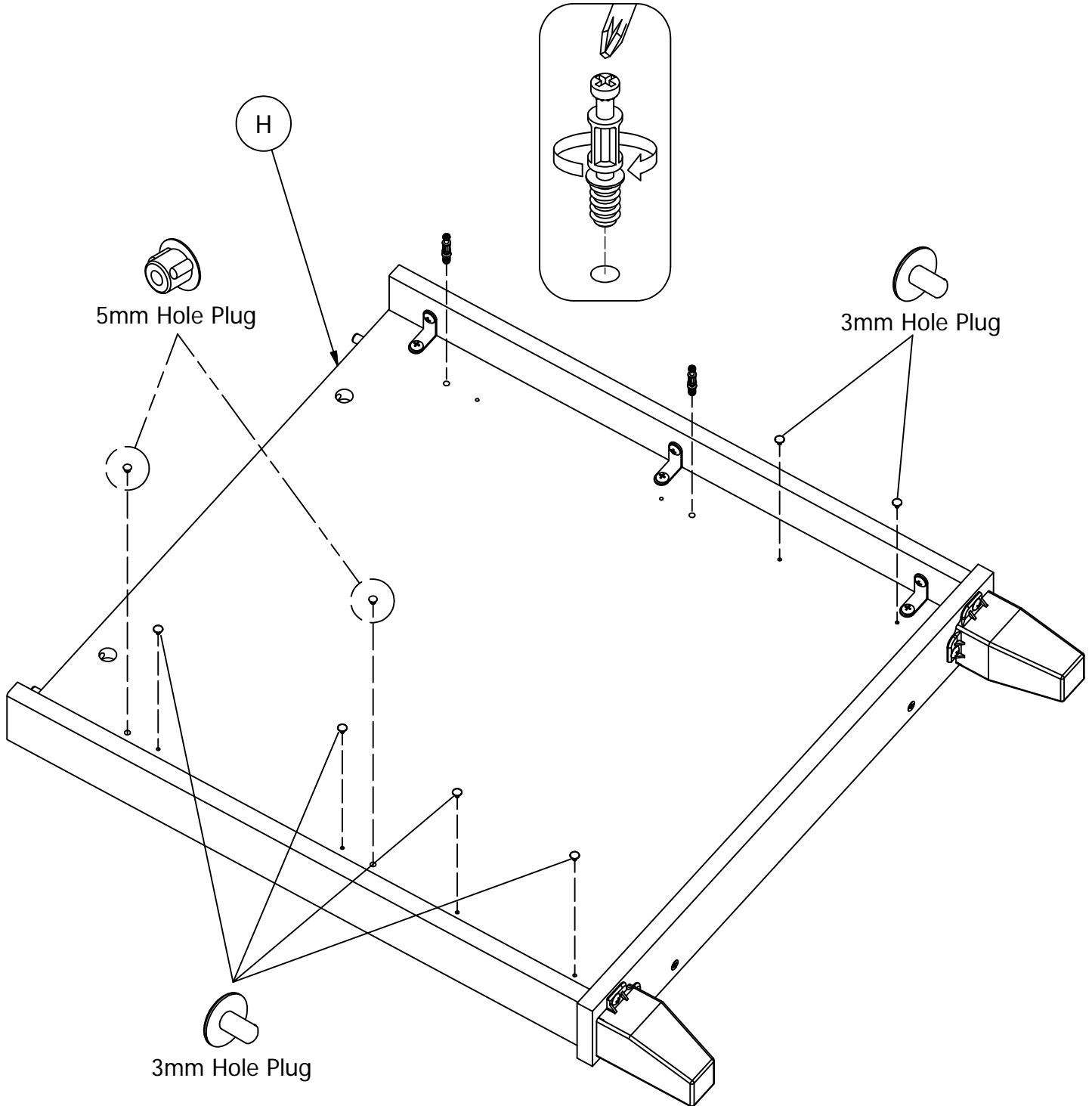

# STEP 29

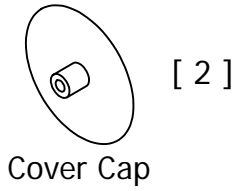
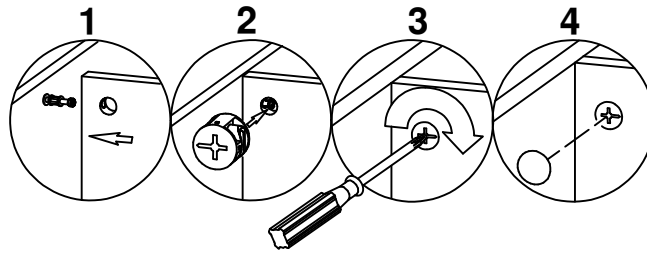
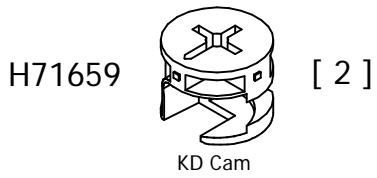

An assistant may be required.  
Un asistente puede ser necesario.  
L'aide d'une autre personne peut s'avérer nécessaire.

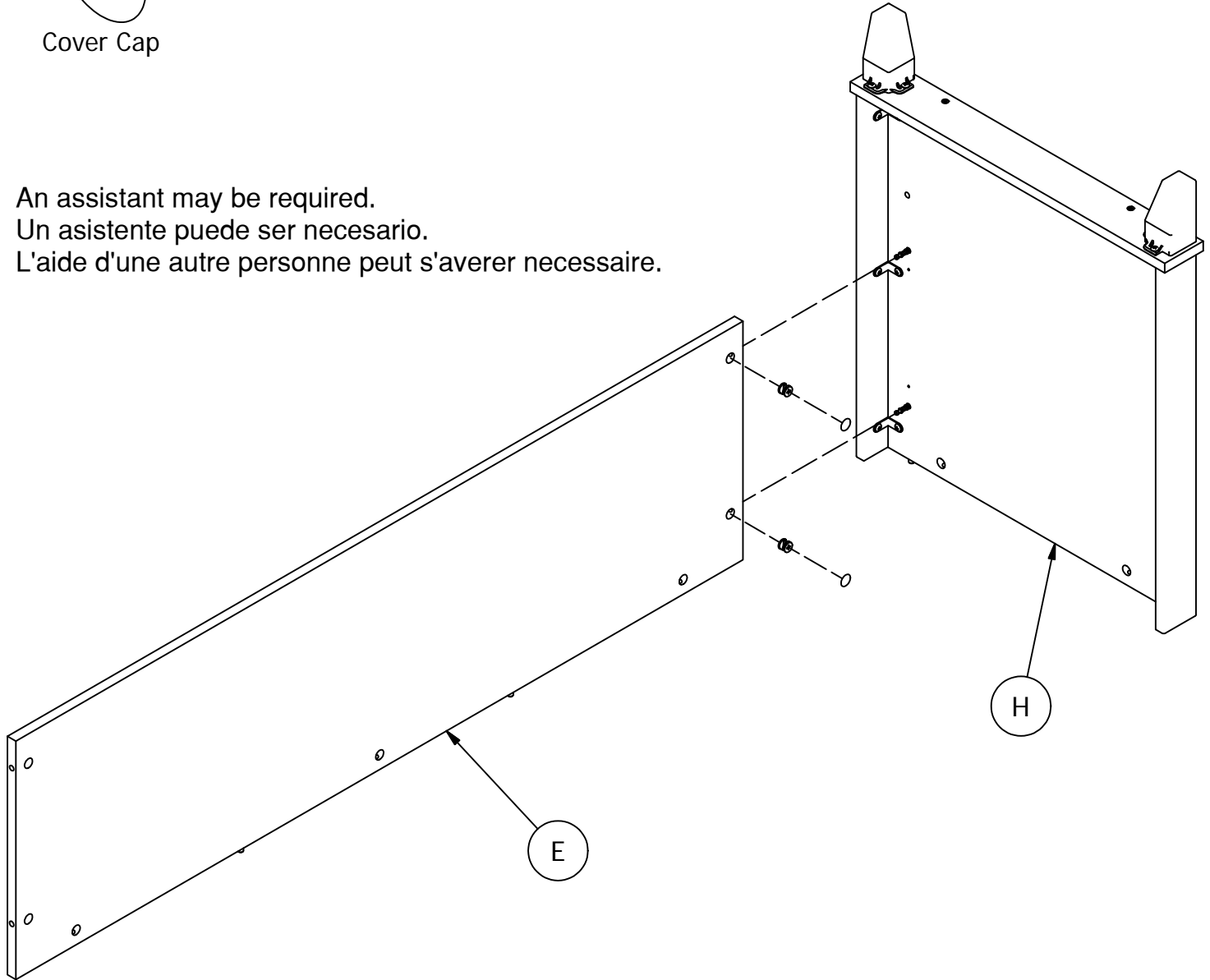

# STEP 30

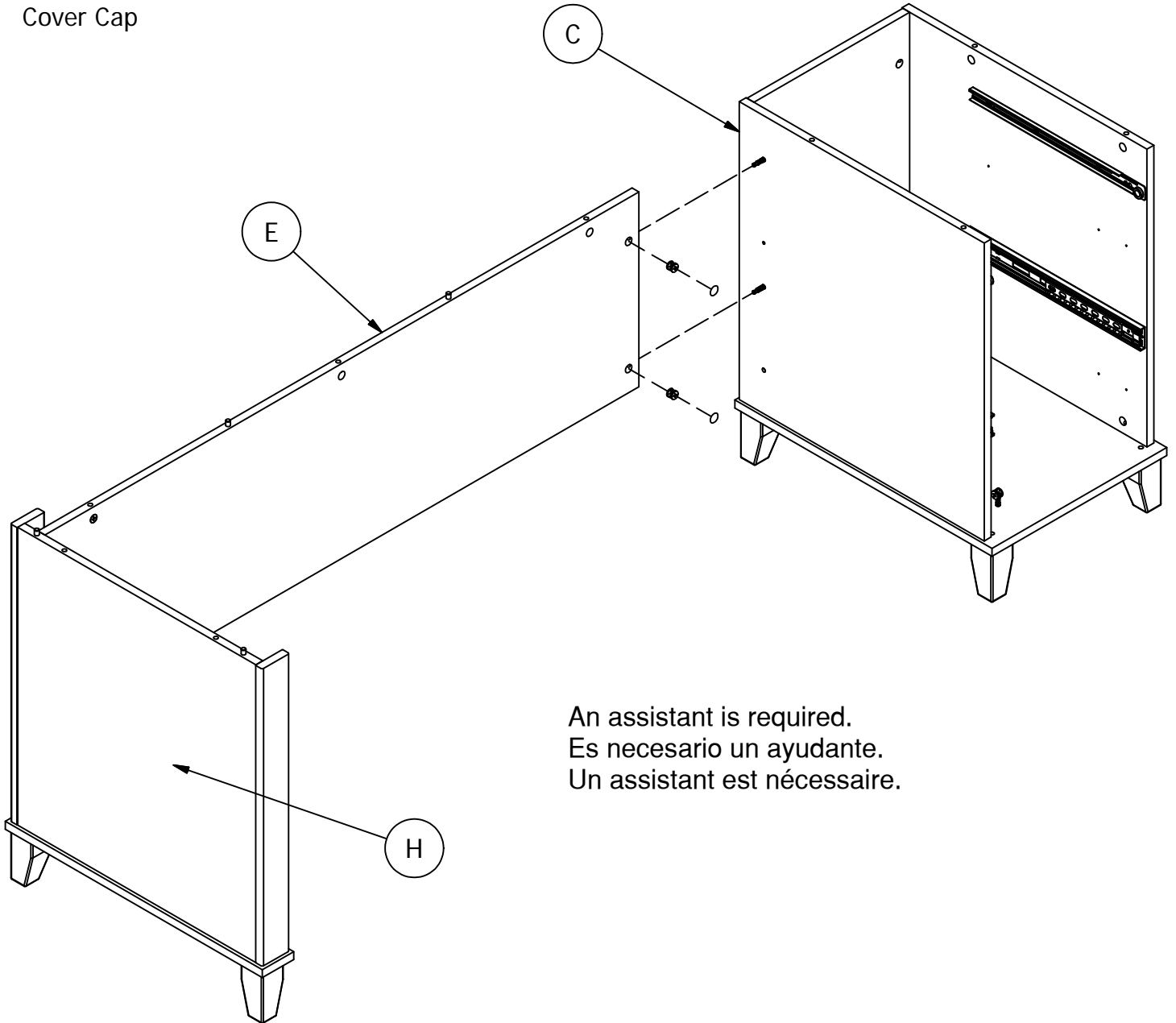
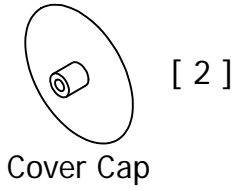
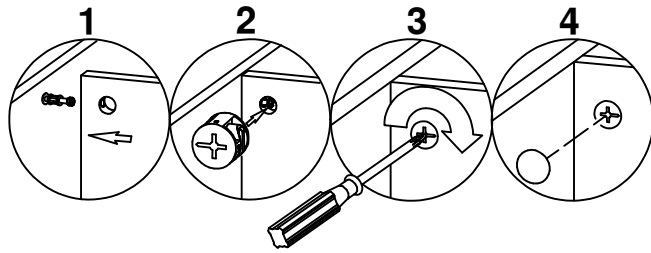
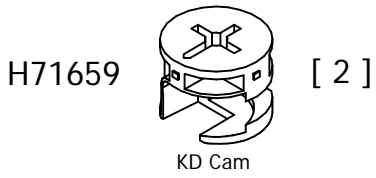

An assistant is required.  
Es necesario un ayudante.  
Un assistant est nécessaire.

**STEP 31**

H72988

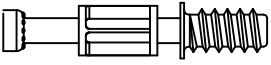

KD Bolt

[ 9 ]

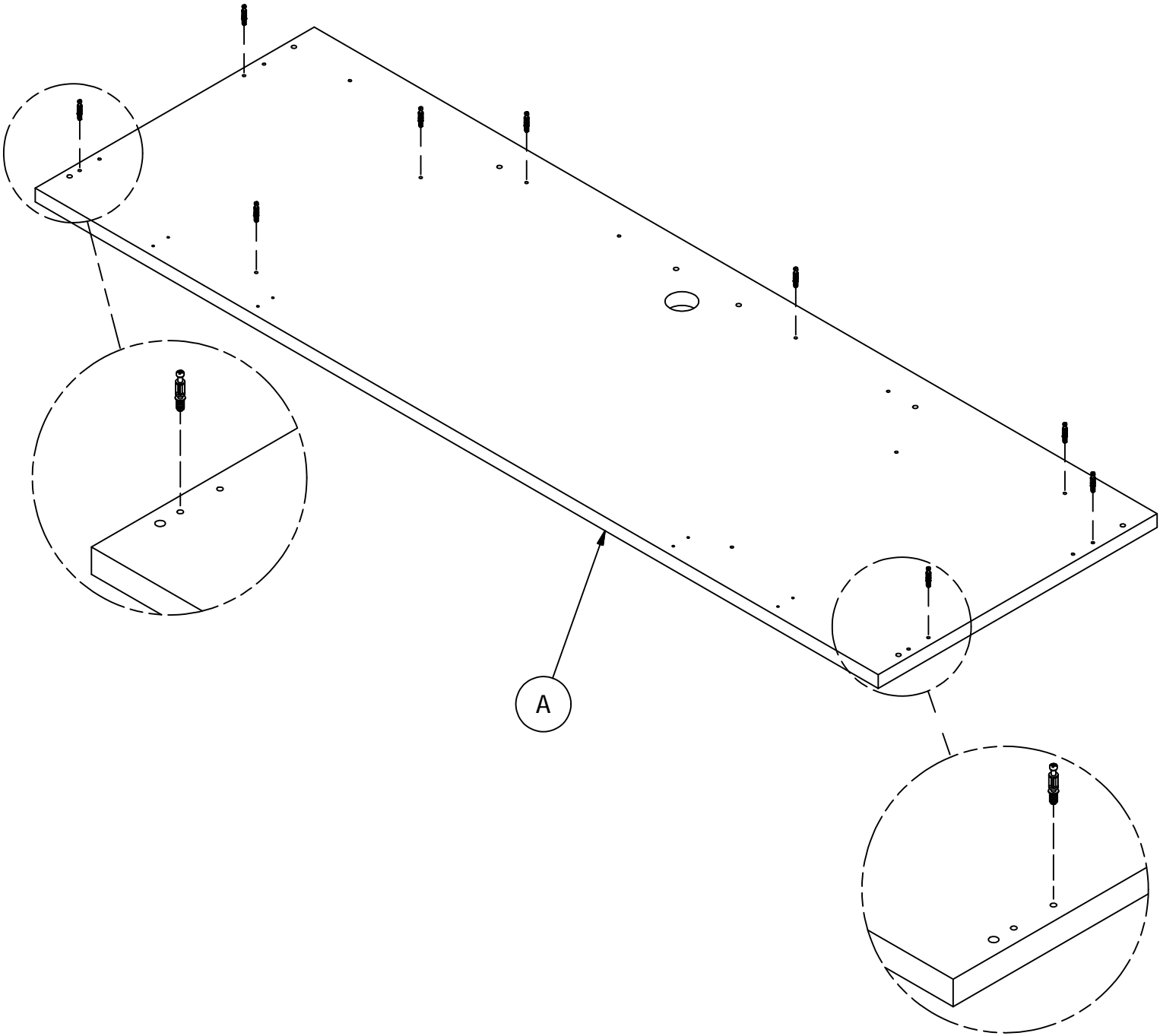
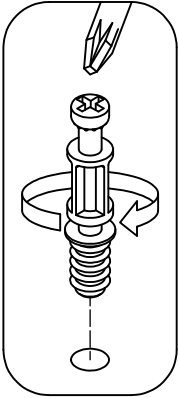

# STEP 32

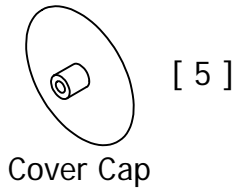
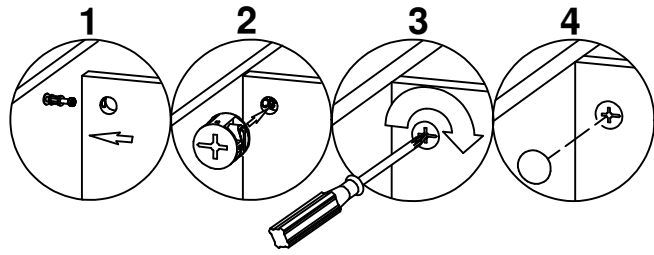
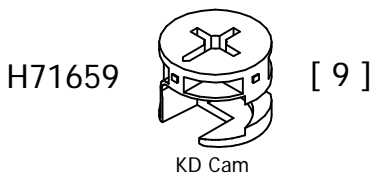

An assistant is required.  
Es necesario un ayudante.  
Un assistant est nécessaire.

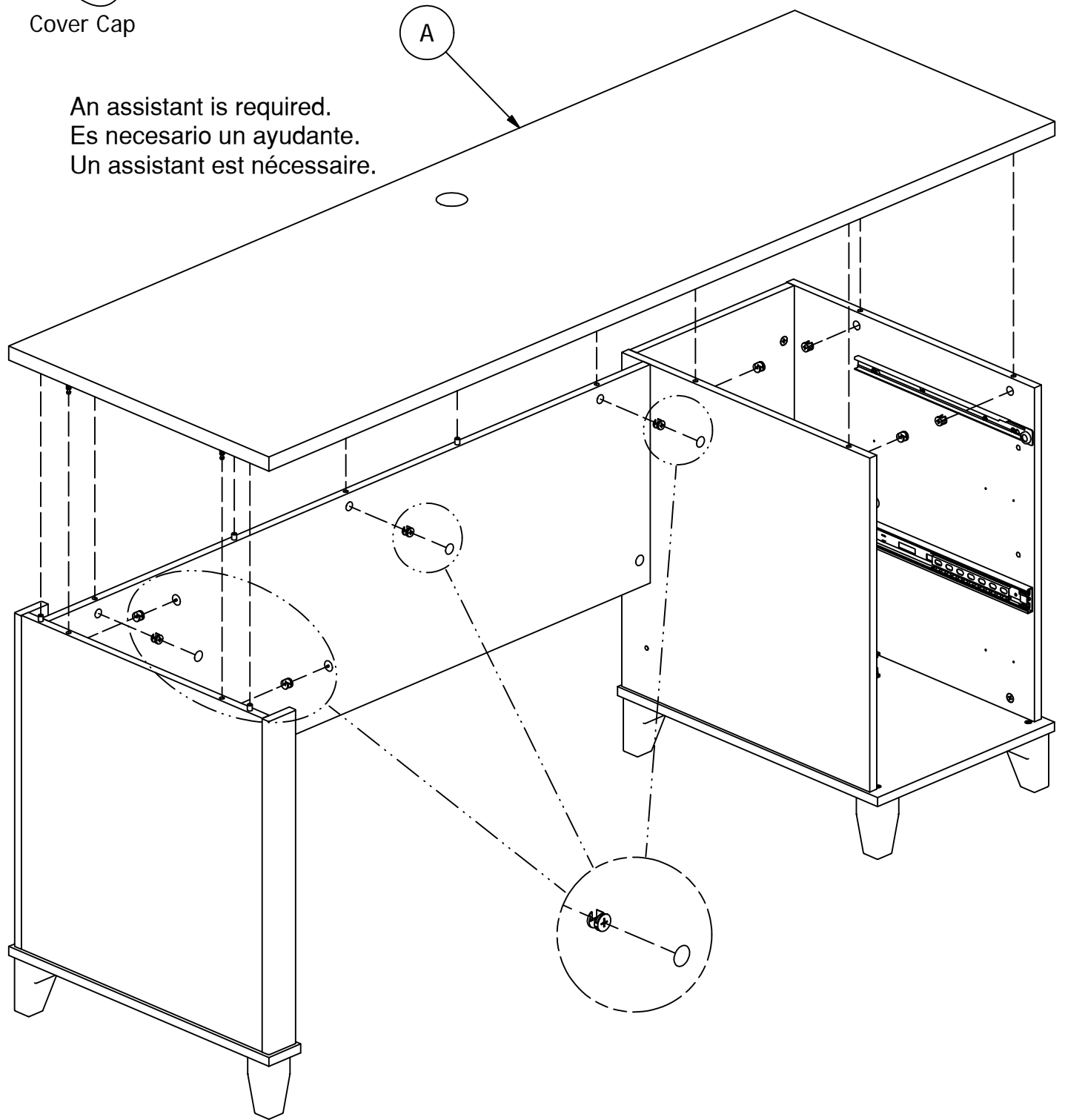

# STEP 33

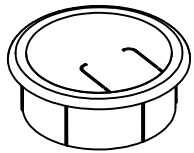

[ 1 ]

Grommet

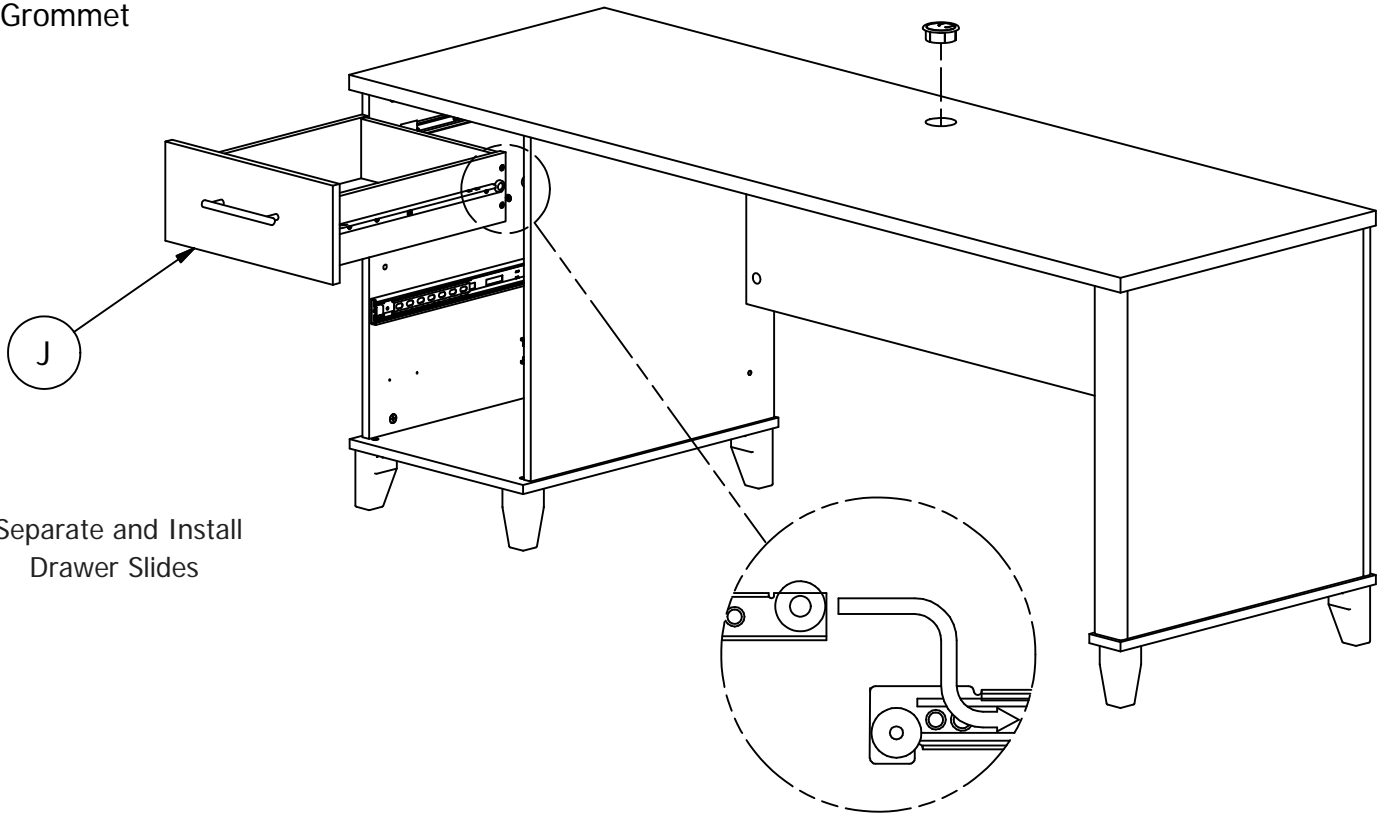

Separate and Install  
Drawer Slides

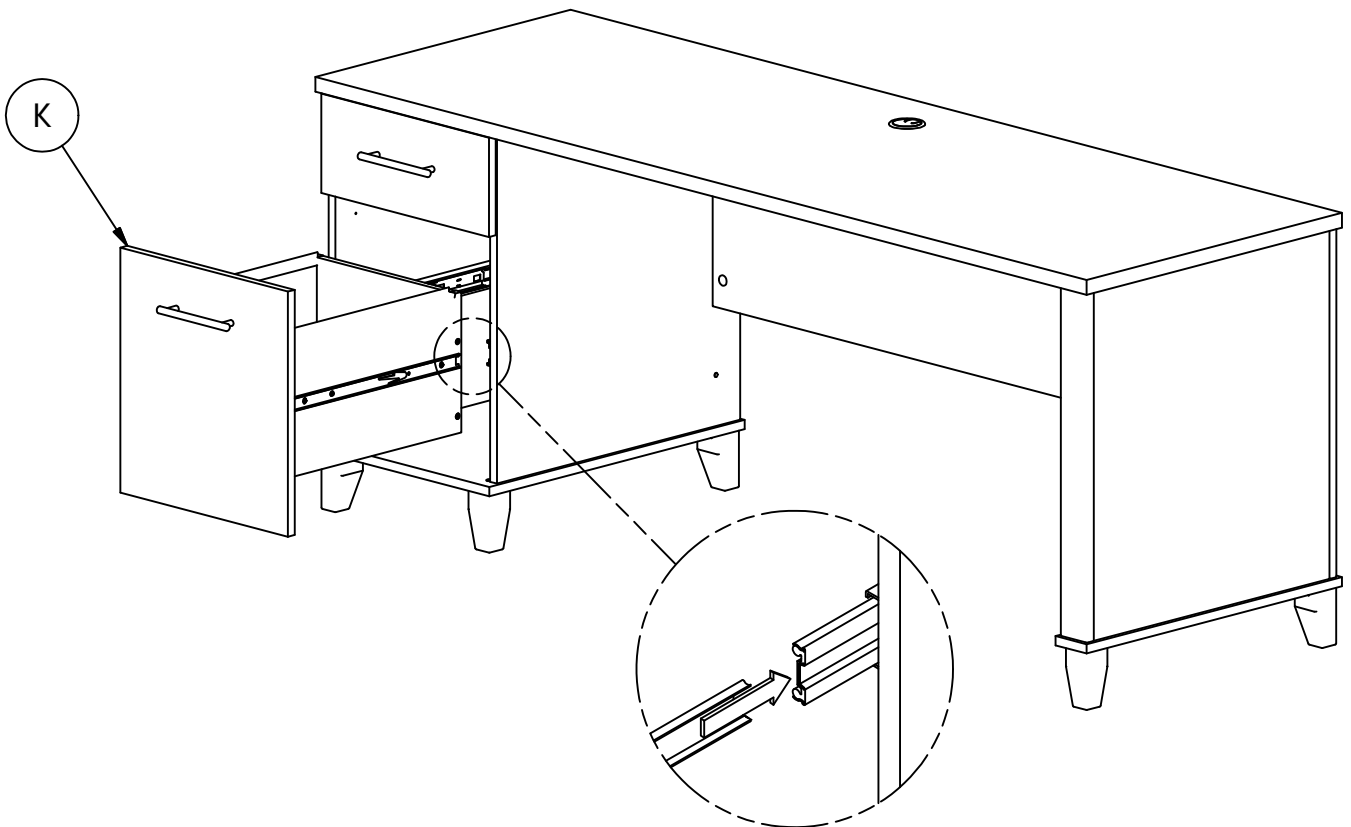

K

**STEP 34**

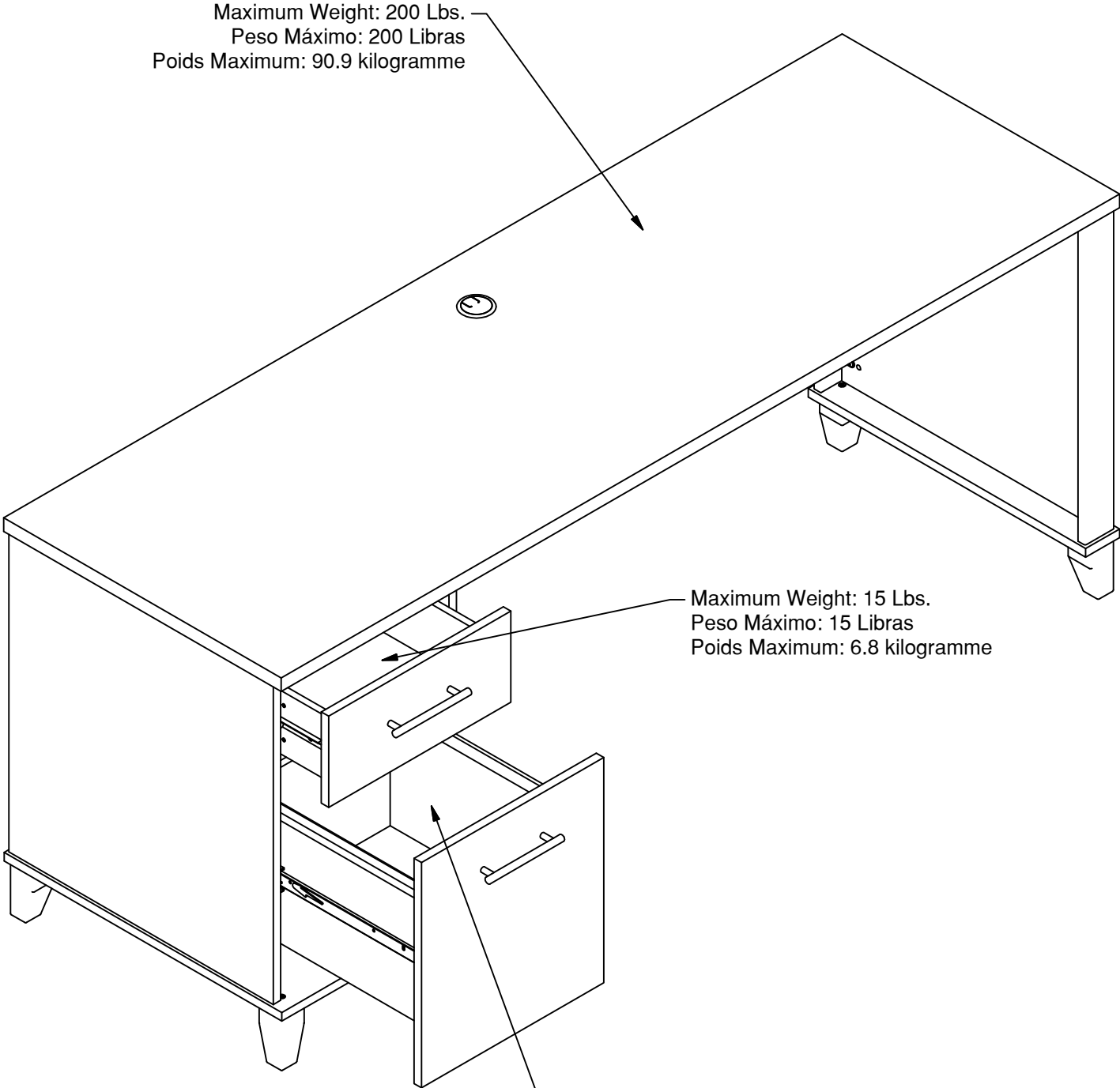

Maximum Weight: 200 Lbs.  
Peso Máximo: 200 Libras  
Poids Maximum: 90.9 kilogramme

Maximum Weight: 15 Lbs.  
Peso Máximo: 15 Libras  
Poids Maximum: 6.8 kilogramme

Maximum Weight: 30 Lbs.  
Peso Máximo: 30 Libras  
Poids Maximum: 13.6 kilogramme

## STEP 35

Adjust Drawer Fronts

### Move unit to final location.

Coloque esta unidad en su posición permanente.

Déplacez l'unité dans l'endroit final.

### Adjust drawer fronts as shown below.

Ajuste la parte delantera de las gavetas según es indicado.

Ajustez les façades de tiroir comme montré ci-dessous.

### Same adjustment steps for BOX and FILE drawers.

Mismos pasos de ajuste para cajones BOX y FILE.

Mêmes étapes de réglage pour les tiroirs BOX et FILE.

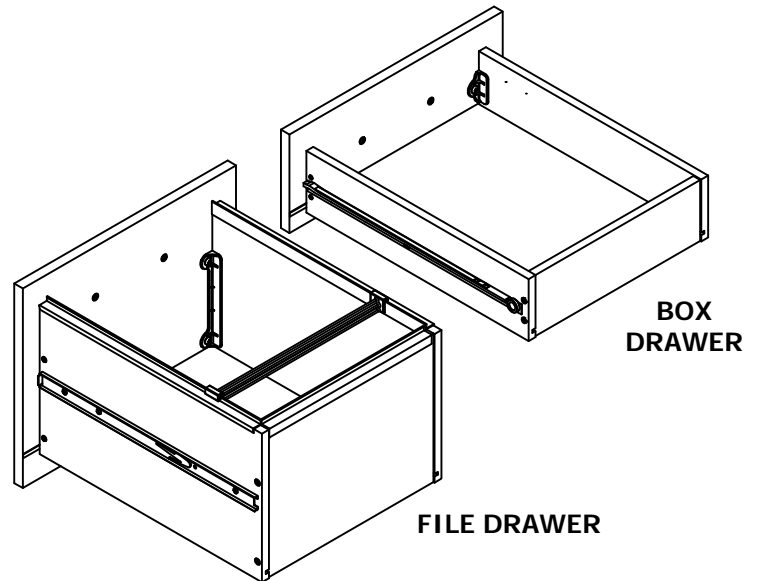
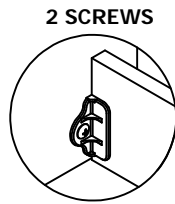
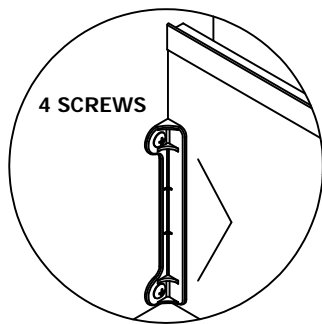

## STEP 1

### Loosen screws on back of drawer front brackets as shown.

Afloje los tornillos en la parte trasera de la gaveta según es indicado.

Desserrez les vis dans les appuis en plastique sur le dos de l'avant de tiroir comme montré.

## STEP 2

### Position drawer front as required.

Ajuste la parte delantera de la gaveta según sea necesario.

Placez l'avant de tiroir comme nécessaire.

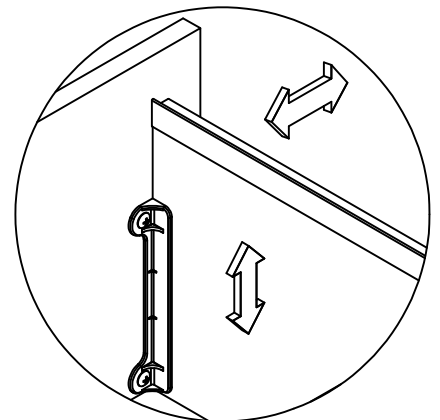
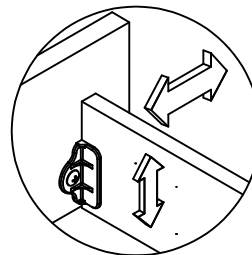
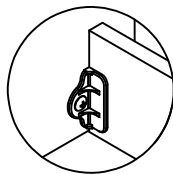
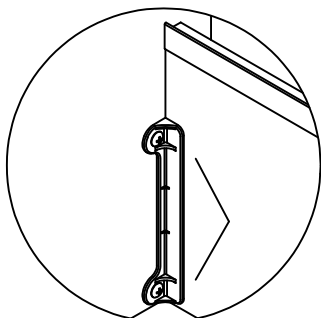

## STEP 3

### Tighten screws while holding drawer front in position.

Apriete los tornillos mientras sujeta la parte delantera de la gaveta en su posición permanente.

Serrez les vis tout en tenant l'avant de tiroir en position.

# WARRANTY INFORMATION/INFORMATIONS POUR LA GARANTIE/INFORMACIÓN DE GARANTÍA

## WRITTEN WARRANTY TO YOU

In order to provide you with timely assistance, please thoroughly inspect your furniture for missing or defective parts immediately after opening the carton. To receive replacement or missing parts under this warranty, call our Consumer Service Department TOLL-FREE at . Please have the Model, Part, and Lot Numbers found in the instruction manual available for your reference. You will also need your sales receipt or other proof of purchase. Replacement part(s) will be shipped to you at no charge with assuming all shipping and handling charges.

This product is warranted to the original purchaser at the time of purchase and for a period of six years thereafter.

We warrant to you, the original purchaser, that our furniture and all its parts and components are free of defects in material or workmanship. "Defects," as used in this warranty, is defined as any imperfection which impairs the use of the furniture product.

Our warranty is expressly limited to the replacement of furniture parts and components. Except for the limitations listed below, for six years after the date of purchase, will replace parts that are defective in material or workmanship.

Limitations involving materials and components: The materials and components listed below are covered according to the following schedule from the date of sale:

- Five Years – Glides, casters, polymer-based components, panel, upholstery fabrics, foam, laminates, veneer finishes, and other covering materials.
- One Year – Metal mechanism and related components in manual height adjustable products.

This warranty applies under conditions of normal use. Our products are not intended for outdoor use. This warranty does not cover: 1) defects caused by improper assembly or disassembly; 2) defects occurring after purchase due to product modification, intentional damage, accident, misuse, abuse, negligence or exposure to the elements; and 3) labor or assembly costs.

IMPLIED WARRANTIES, INCLUDING THE WARRANTY OF MERCHANTABILITY, SHALL NOT EXTEND BEYOND THE DURATION OF THE WRITTEN WARRANTY STATED ABOVE, AND IN NO EVENT SHALL BE LIABLE FOR INCIDENTAL OR CONSEQUENTIAL DAMAGES RESULTING FROM USE OF THE PRODUCT. Some states do not allow a limitation on how long an implied warranty lasts or the exclusion or limitation of incidental or consequential damages, so the above limitation and exclusion may not apply to you.

This warranty gives you specific legal rights. You may also have other rights that may vary from state to state.

## VOTRE GARANTIE

Afin de vous assister rapidement, veuillez inspecter votre mobilier en détail immédiatement après l'ouverture du carton en cas de pièces manquantes ou défectueuses. Pour recevoir une pièce de rechange ou manquante couverte par cette garantie, appelez notre département de service clientèle GRATUITEMENT au . Veuillez tenir à disposition les numéros de modèle, de pièce et de lot qui se trouvent dans le manuel d'instruction pour votre référence. Vous aurez également besoin de votre reçu ou d'une autre preuve d'achat. La (les) pièce(s) de rechange vous sera (seront) envoyée(s) sans frais, se chargeant de tous les frais d'expédition.

Tout le produit est garanti à l'acheteur original à partir de la date d'achat pour une période de six ans.

Nous vous garantissons, à vous l'acheteur original, que notre mobilier et toutes ses pièces et composants sont sans défaut de matériau ou de fabrication. Le terme "défauts" utilisé dans cette garantie, est défini comme étant toutes les imperfections qui compromettent l'utilisation du meuble.

Notre garantie est expressément limitée au remplacement des pièces et des composants du mobilier. Sauf les limitations énumérées ci-dessous, pendant six ans après la date d'achat, remplacera toute pièce défectueuse dans le matériau ou sa fabrication.

Limitations impliquant des matériaux et des composants: Les matériaux et composants énumérés ci-dessous sont couverts conformément au calendrier suivant à compter de la date de vente:

- Cinq ans - Glissements, roulettes, composants à base de polymères, panneaux, tissus d'ameublement, mousse, stratifiés, finitions de placage et autres matériaux de revêtement.
- Un an - Mécanisme métallique et composants associés dans des produits à réglage manuel de la hauteur.

Cette garantie d'applique sous des conditions d'utilisation normale. Nos produits ne sont pas destinés à être utilisés en plein air. Cette garantie ne couvre pas: 1) les défauts causés par un mauvais assemblage ou démontage, 2) les défauts ayant lieu après l'achat et dus à la modification du produit, des dommages intentionnels, des accidents, une mauvaise utilisation, un mauvais traitement, la négligence ou l'exposition aux éléments, et 3) les frais de main d'œuvre ou d'assemblage.

LES GARANTIES TACITES, Y COMPRIS LA GARANTIE DE QUALITE MARCHANDE, NE S'ETENDRONT PAS AU-DELA DE LA DUREE ECRITE CITEE CI-DESSUS, ET NE SERA EN AUCUN CAS RESPONSABLE DES DOMMAGES ACCESSOIRES OU INDIRECTS RESULTANT DE L'UTILISATION DU PRODUIT. Certains états ne permettent pas d'appliquer une limite à la durée de la garantie tacite, ni une exclusion ou limitation des dommages accessoires ou indirects; dans ce cas les limitations ou exclusion ci-dessus peuvent ne pas s'appliquer à vous.

Cette garantie vous donne des droits légaux spécifiques. Il se peut que vous ayez également d'autres droits qui peuvent varier d'un état à l'autre.

## GARANTIA ESCRITA DE PARA USTED

Para brindarle asistencia oportuna, por favor, verifique detalladamente que a su mueble no le falte o tenga piezas defectuosas inmediatamente después de abrir la caja. Pararecibir un reemplazo o la parte faltante bajo esta garantía, llame a nuestro Departamento de Servicio al Consumidor GRATIS al . Sírvase traer los números de modelo, parte y lote que se encuentran en el manual de instrucciones disponible para su referencia. Además, necesitará el recibo de su compra u otra prueba de compra. La(s) pieza(s) de reemplazo le será(n) enviada(s) sin recargo por asumiendo los gastos de envío y manipuleo.

Todo mueble de es garantizado al comprador original al momento de la compra y por un periodo de seis años en adelante.

Le garantizamos a usted, el comprador original, que nuestros muebles sus partes y componentes están libres de defectos en materiales o trabajo. "Defectos", según se usa en esta garantía, se define como una imperfección que perjudica el uso del producto mobiliario.

Nuestra garantía se limita expresamente al reemplazo de partes y componentes mobiliarios. Excepto las limitaciones enumeradas a continuación, durante seis años después de la fecha de compra, reemplazará cualquier parte defectuosa en material o trabajo.

Limitaciones que involucran materiales y componentes: Los materiales y componentes que se enumeran a continuación están cubiertos de acuerdo con el siguiente calendario a partir de la fecha de venta:

- Cinco años: deslizadores, ruedas, componentes a base de polímeros, paneles, telas de tapicería, espuma, laminados, acabados de enchapado y otros materiales de recubrimiento.
- Un año: mecanismo de metal y componentes relacionados en productos de altura manual.

Esta garantía se aplica bajo condiciones de uso normal. Nuestros productos de no son para uso en exteriores. Esta garantía no cubre: 1) defectos causados por un ensamblaje o desensamblaje inadecuado; 2) defectos que ocurran después de la compra debido a modificación del producto, daño intencional, accidente, mal uso, abuso, negligencia o exposición a los elementos; y 3) costos de trabajo o ensamblaje.

LAS GARANTÍAS IMPLICADAS, INCLUYENDO LA GARANTÍA DE COMERCIABILIDAD, NO SE EXTENDERÁN MÁS ALLÁ DE LA DURACIÓN DE LA GARANTÍA ESCRITA MENCIONADA, Y EN NINGÚN CASO SERÁ RESPONSABLE POR DAÑOS INCIDENTALES O CONSIGUIENTES COMO RESULTADO DEL USO DEL PRODUCTO. Algunos estados no permiten una limitación sobre el tiempo de duración de la garantía implicada o la exclusión o limitación de daños incidentales o consiguientes, de manera que la limitación y exclusión mencionadas pueden no aplicarse para usted.

Esta garantía le otorga derechos legales específicos. Puede también tener otros derechos que pueden variar según los estados.

## Thank you for purchasing

We trust that you will be completely satisfied with your product for many years to come.

Our products are backed by a 6-year warranty and crafted with today's styles in mind for the way you work. **Do not return product to store**

## Merci d'avoir acheté ce produit

Nous sommes sûr que vous serez complètement satisfait de votre meuble pendant de nombreuses années. Les produits sont garantis pendant 6 ans et sont conçus dans les styles actuels tout en gardant à l'esprit votre façon de travailler. **Ne renvoyez pas le produit au magasin, contactez-nous d'abord au**

## Gracias por comprar este producto de

. Confiamos que usted estará completamente satisfecho con su mueble por muchos años. Los productos de tienen 6 años de garantía y son diseñados con los estilos de hoy en mente para la manera que usted vive.

**No devuelva el producto a la tienda, primero comuníquese con nosotros al**

# IT'S AS EASY AS 1,2,3

## Assembly tips:

1. Read the instructions and become familiar with the parts.
2. Ensure this carton contains all parts, fasteners and hardware.
3. To protect floors, assemble the furniture on the carton.
4. An assistant may be helpful.
5. Use of power tools is not recommended.

## Conseils d'assemblage:

1. Lisez les instructions et familiarisez-vous avec les pièces.
2. Assurez-vous que le carton contient toutes les pièces, toutes les pièces de fixation et toute la quincaillerie.
3. Pour protéger vos sols, assemblez le meuble sur le carton.
4. Il peut être utile de vous faire aider.
5. L'utilisation d'outils électriques n'est pas recommandée.

## Consejos de Ensamblaje:

1. Lea las instrucciones y familiarícese con las partes.
2. Asegúrese de que esta caja contenga todas las piezas, los sujetadores y el equipo.
3. Para proteger el piso, ensamble el mueble en el carton.
4. Un asistente puede serle útil.
5. El uso de herramientas eléctricas no se recomienda.



## CONSUMER SERVICE

## YOU CAN DEPEND ON

**Questions?** Operators are standing by at our TOLL-FREE help line to assist you with assembly; and, if necessary, to quickly replace damaged/missing parts. Assistance is available 5 days a week. Simply have your store receipt, instruction manual, and part number/description ready when you call our TOLL-FREE help line. It's that easy.

UN SERVICE CLIENTELE SUR LEQUEL VOUS POUVEZ COMPTER

**Des questions?** Des opérateurs sont prêts sur notre ligne d'assistance GRATUITE pour vous aider à l'assemblage et, si nécessaire, remplacer rapidement les pièces endommagées/manquantes. L'assistance est disponible 5 jours par semaine. Ayez simplement votre reçu de magasin, votre manuel d'instruction et le numéro de pièces/description à votre disposition lorsque vous appelez notre ligne d'assistance GRATUITE. C'est aussi simple que ça.

SERVICIO AL CONSUMIDOR CON EL QUE PUEDE CONTAR

**¿Preguntas?** Los operadores están listos para ayudarlo con el ensamblaje a través de una línea de ayuda GRATUITA, y en caso de ser necesario, reemplazar de inmediato las piezas dañadas o faltantes. La asistencia está disponible los 5 días de la semana. Solamente tenga listos su recibo de compra, manual de indicaciones y número/descripción de la pieza al momento de llamarnos a la línea de ayuda GRATUITA. Es así de sencillo.