

OFFICE CHAIR

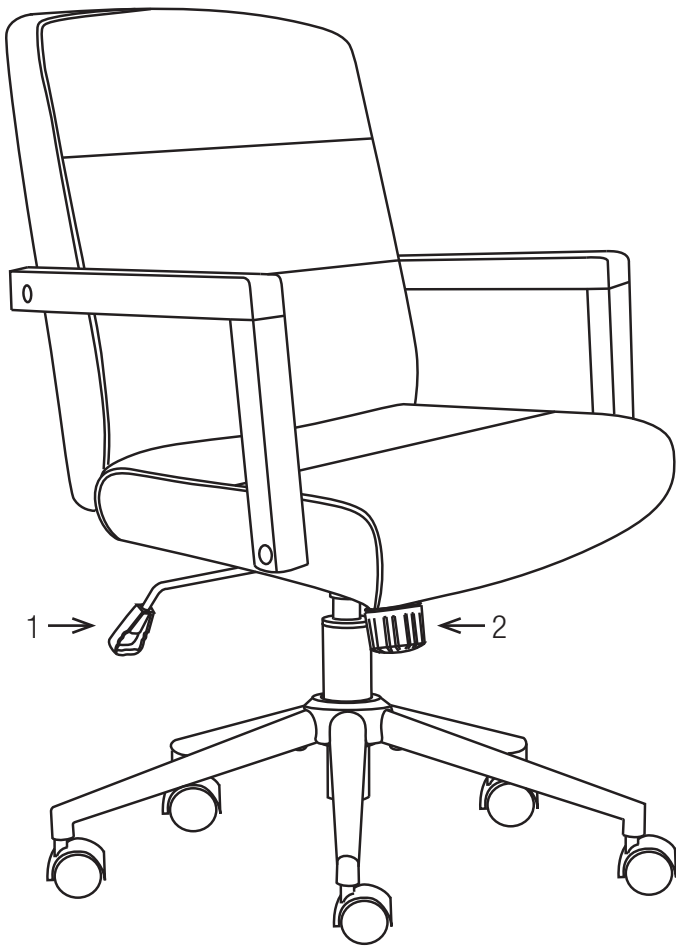

Assembly Instructions - Important:

Carefully unpack and identify each component before attempting to assemble. Refer to parts list. Please take care when assembling the unit and always set the parts on a clean, soft surface. If you require any assistance with assembly, parts or information on other products, please visit our website: www.officestar.net or call or write us.



FEATURES

• PNEUMATIC SEAT HEIGHT ADJUSTMENT

To raise seat, remove pressure from seat and pull lever (1) up. To lower seat, sit on chair and pull lever (1) up.

NOTE: It is normal for chair to slightly lower under body weight.

• LOCKING TILT ADJUSTMENT

For individual comfort, this chair has been equipped with an adjustment that will allow the user to change the tension of the tilting feature. Turn knob (2) clockwise to increase tension and counter-clockwise to decrease or ease the tension. To lock, return chair to the upright position and push lever (1) in. To unlock, pull lever (1) out.

NOTE: Be careful not to loosen back tilt adjustment knob completely.

1. Do not use this product unless all screws and bolts are securely tightened.
2. Check that all screws and bolts are tight every three months or as needed.
3. Dispose of packing material properly. Do not use plastic cover as head covering. It may cause suffocation.
4. Do not use this product as a stepladder.
5. Use this product for its intended purpose only.
6. **FOR INDOOR RESIDENTIAL USE ONLY.**

PARTS

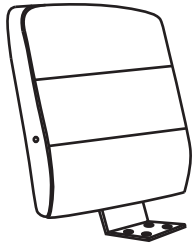

(A) Backrest (1 PC)

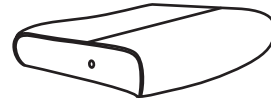

(B) Seat Cushion (1 PC)

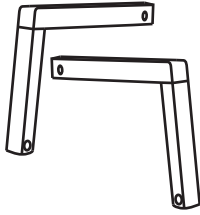

(C) Arm (2 PCS)

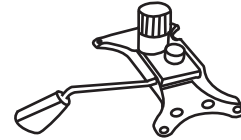

(D) Seat Plate (1 PC)

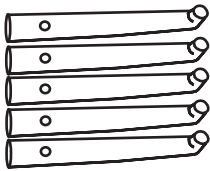

(E) Foot (5 PCS)

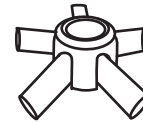

(F) Base (1 PC)







(G) Caster (5 PCS)

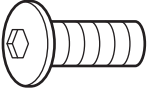
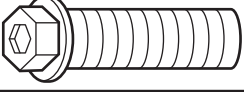
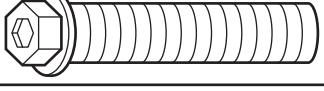

(H) Pneumatic Cylinder (1 PC)

HARDWARE LIST

NO	DRAWING	DESCRIPTION	SIZE	QUANTITY
1		Allen Bolt	6mm x 12mm	5 PCS
2		Allen Bolt	8mm x 22mm	2 PCS
3		Allen Bolt	8mm x 32mm	6 PCS
4		Allen Bolt	8mm x 40mm	4 PCS
5		Plastic Cap	N/A	4 PCS
6		Allen Wrench	M5	1 PC

STEP 1

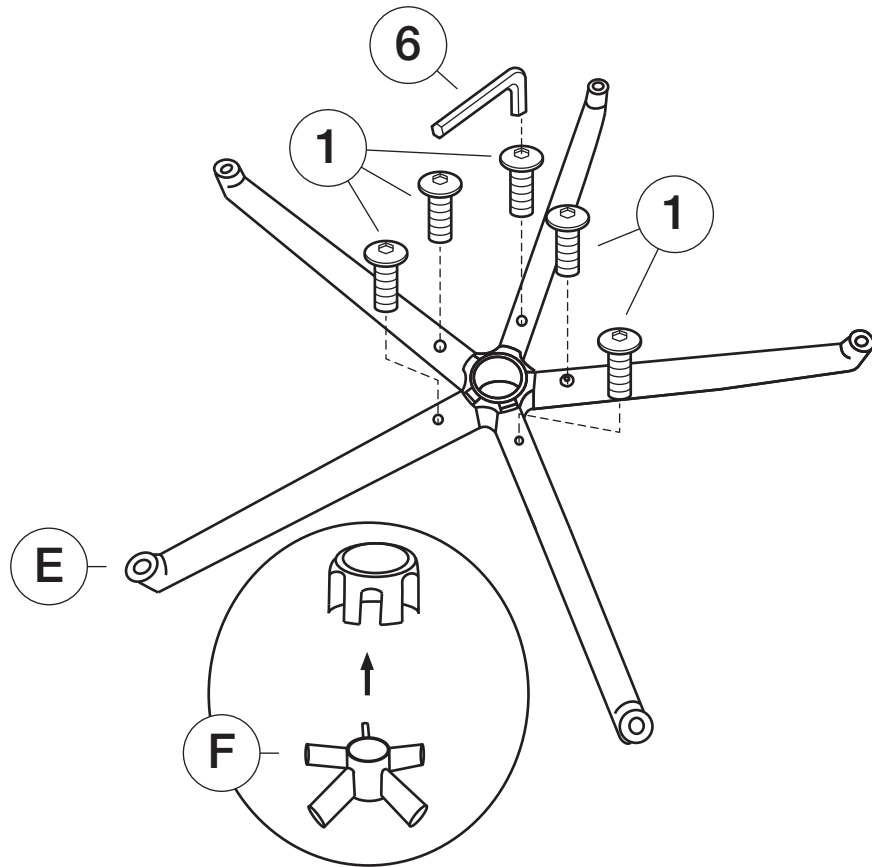

FULLY TIGHTEN ALL BOLTS

STEP 2

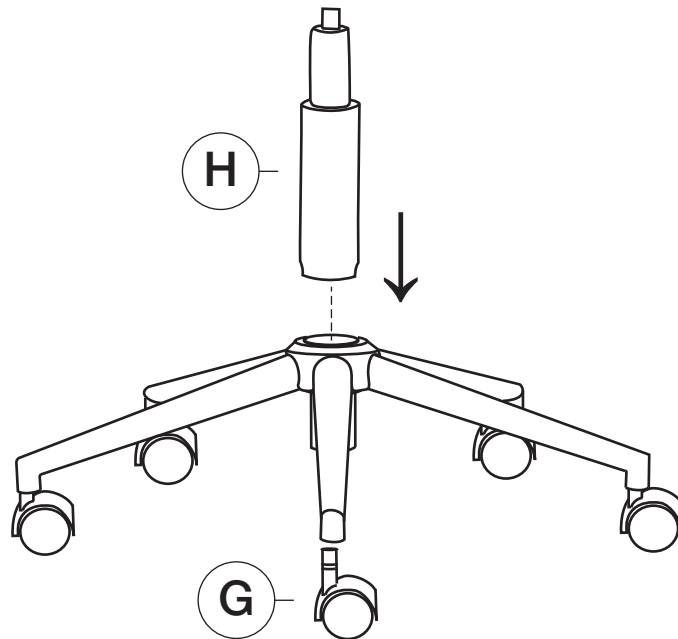

STEP 3

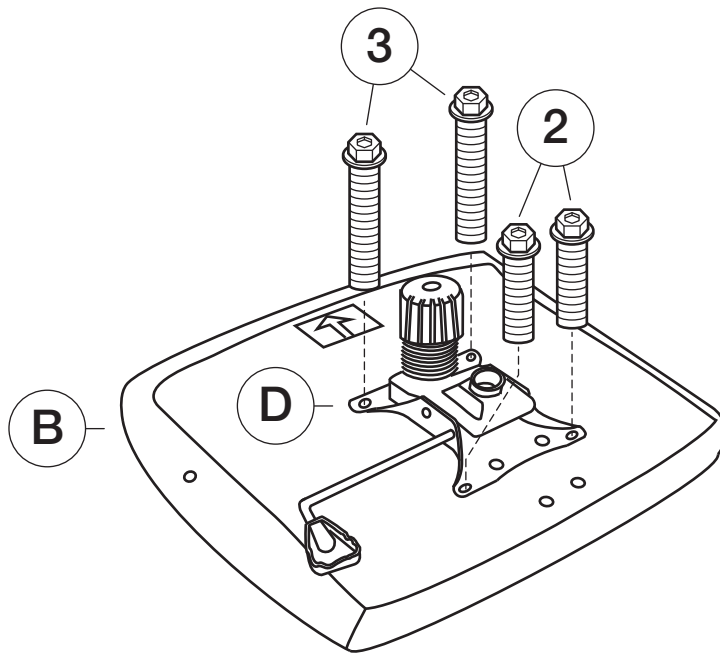

DO NOT FULLY TIGHTEN BOLTS

STEP 4

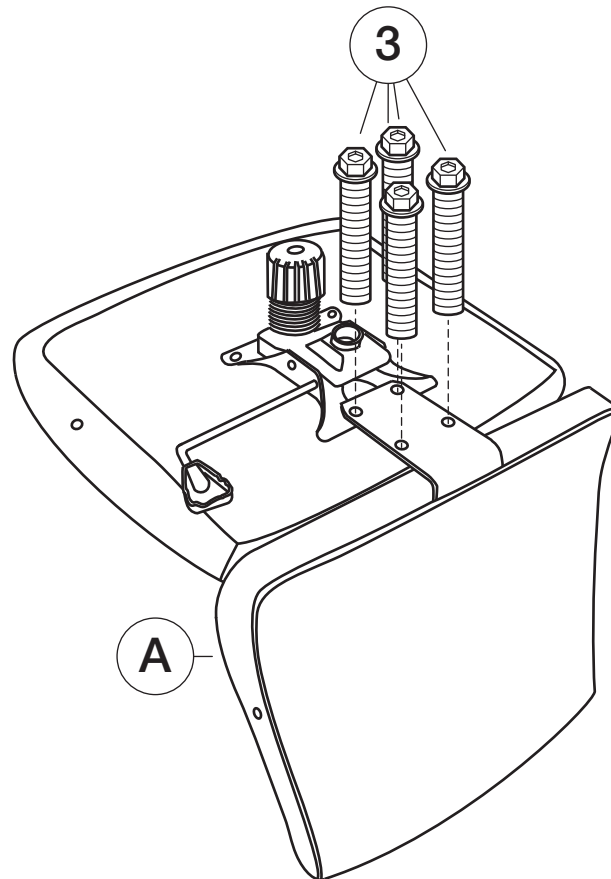

FULLY TIGHTEN ALL BOLTS FROM STEPS 3 AND 4

STEP 5

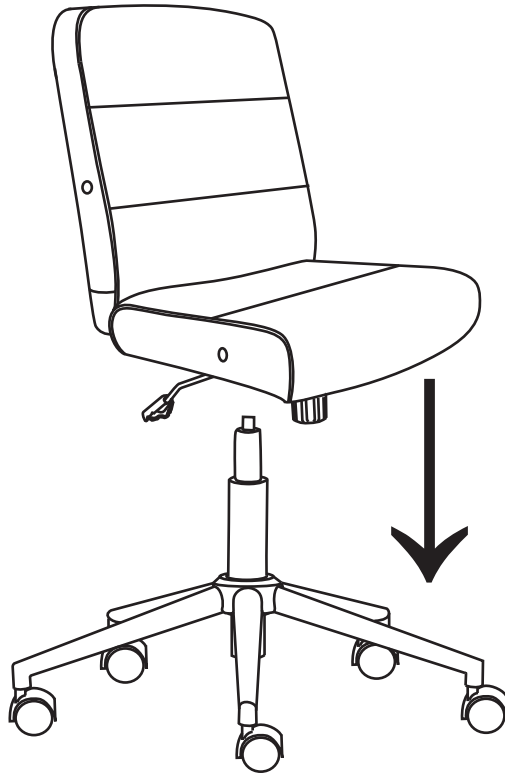

STEP 6

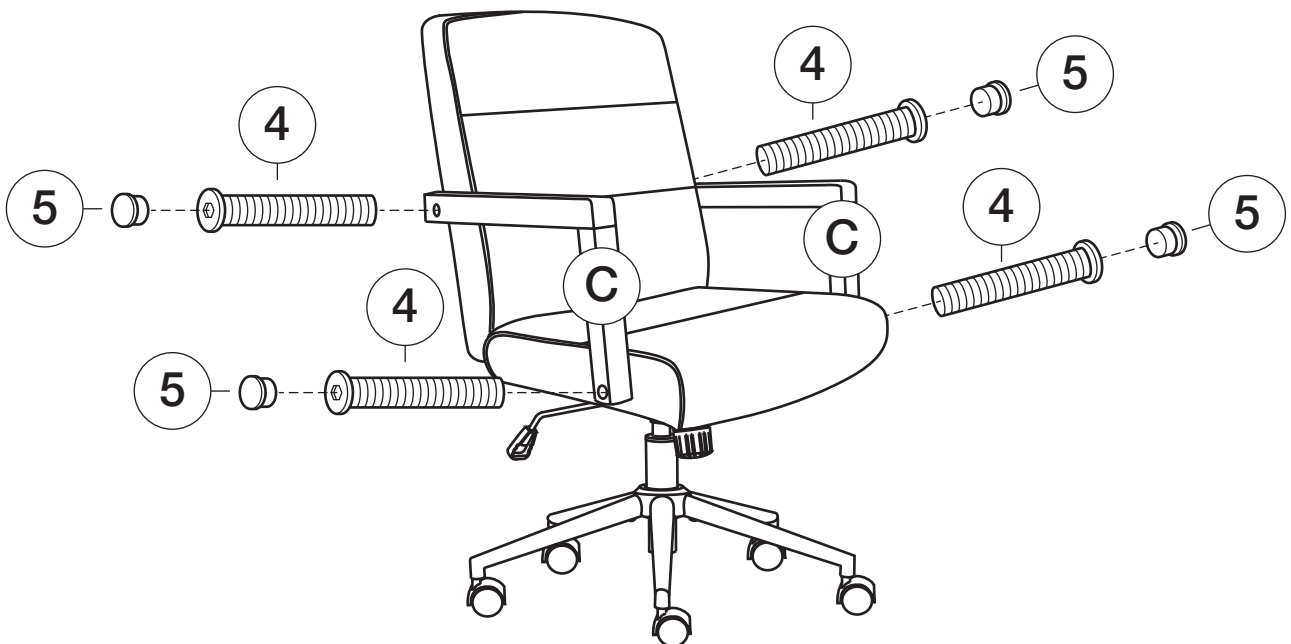

FULLY TIGHTEN ALL BOLTS