

Assembly Instructions

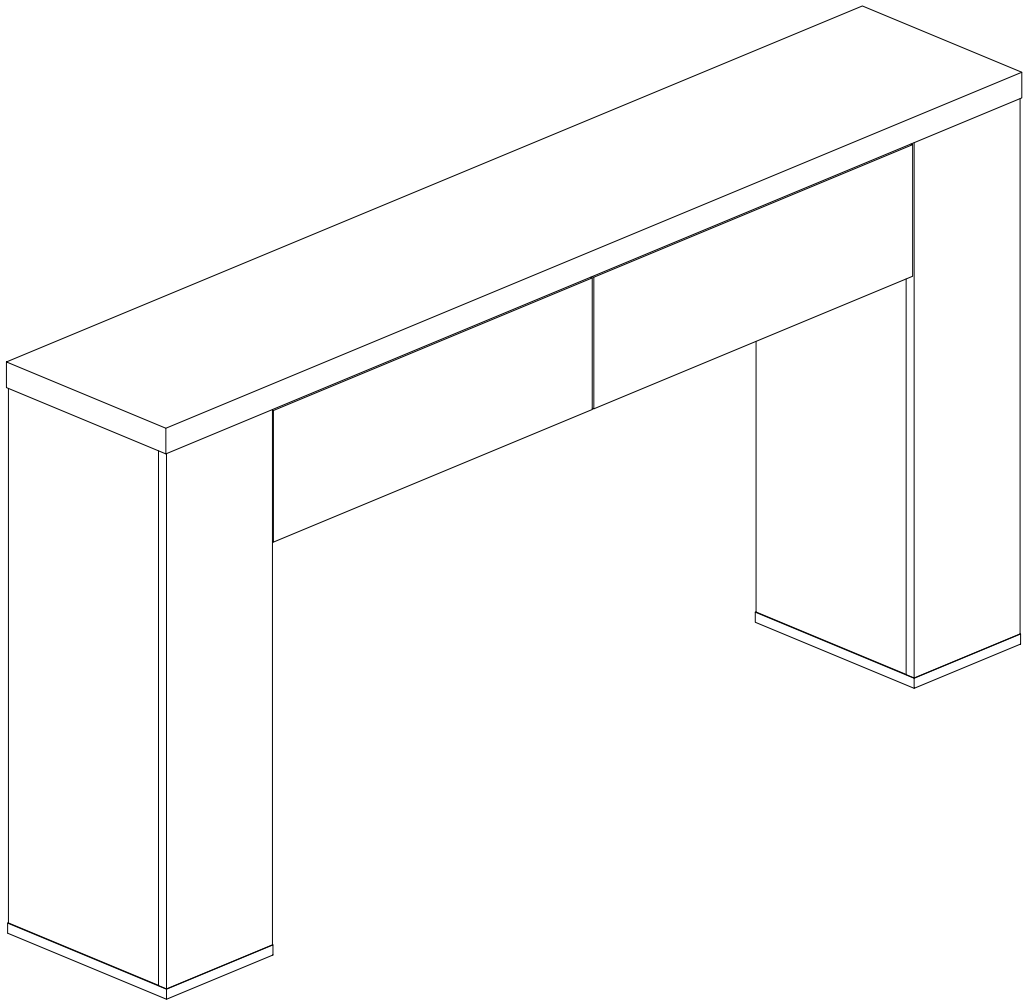

Console Table

Model No.
HOGA-RY0361

Contact Us

We're here to help you.



Your satisfaction is our top priority. If you encounter any issues with this product, such as missing or damaged parts, we're here to help. Please retain the original packaging and take photos of the packaging and the product, then contact us as soon as possible.

Warm Tips

1. Carefully read these instructions and keep them for future reference.
2. Check the parts list and confirm everything's there before starting assembly.
3. When assembling, put all parts on a soft, smooth surface like a carpet to avoid scratches.
4. Don't fully tighten screws until all parts are confirmed in place to avoid misalignment.

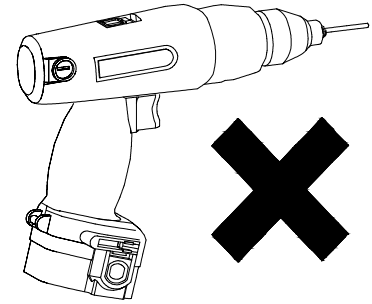
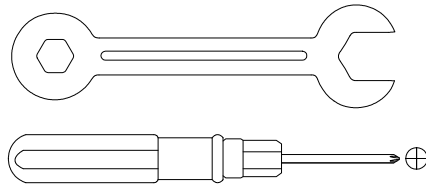
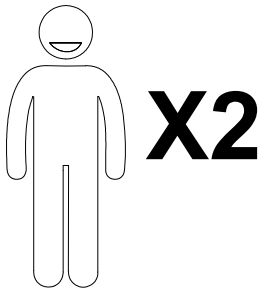

We recommend using hand tools for assembly.

If an electric screwdriver is used, reduce power and torque to avoid damage to the product.

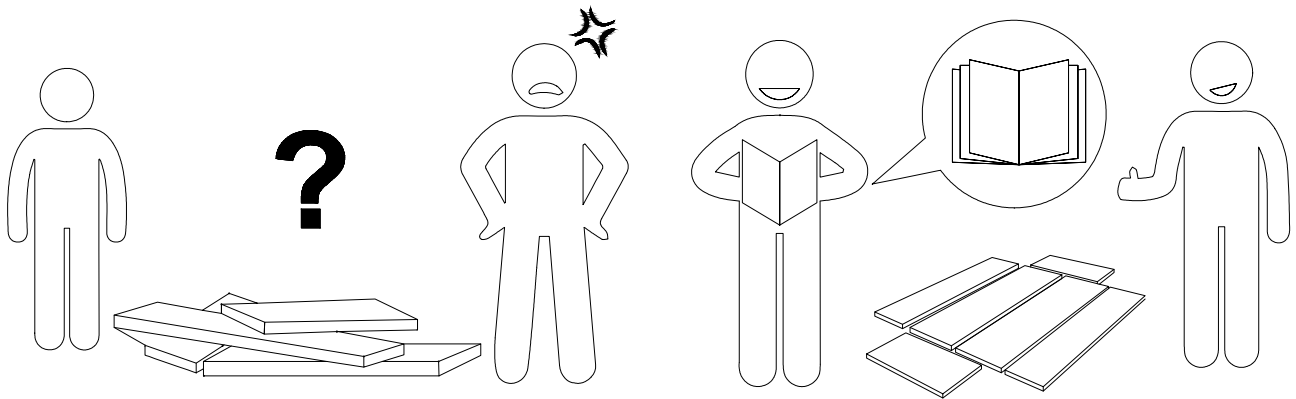

Install the Anti-Tip Straps

Using the anti-tip straps can reduce the risk of tipping over, but can not eliminate it.

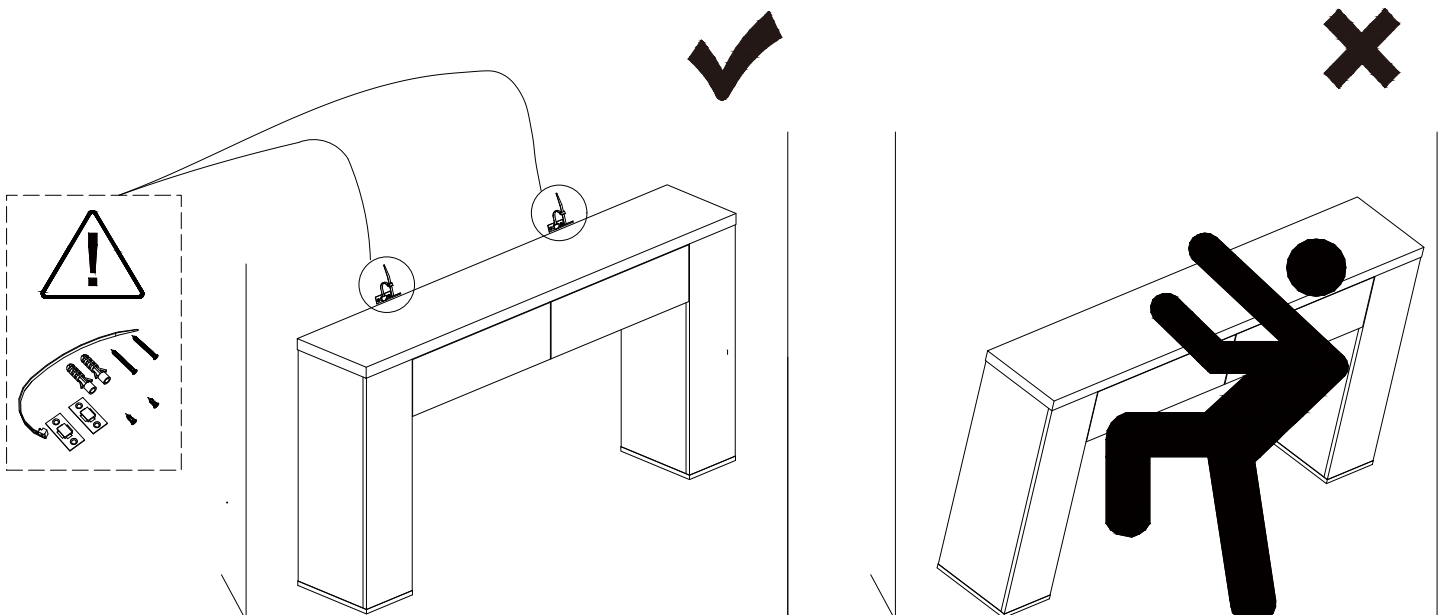

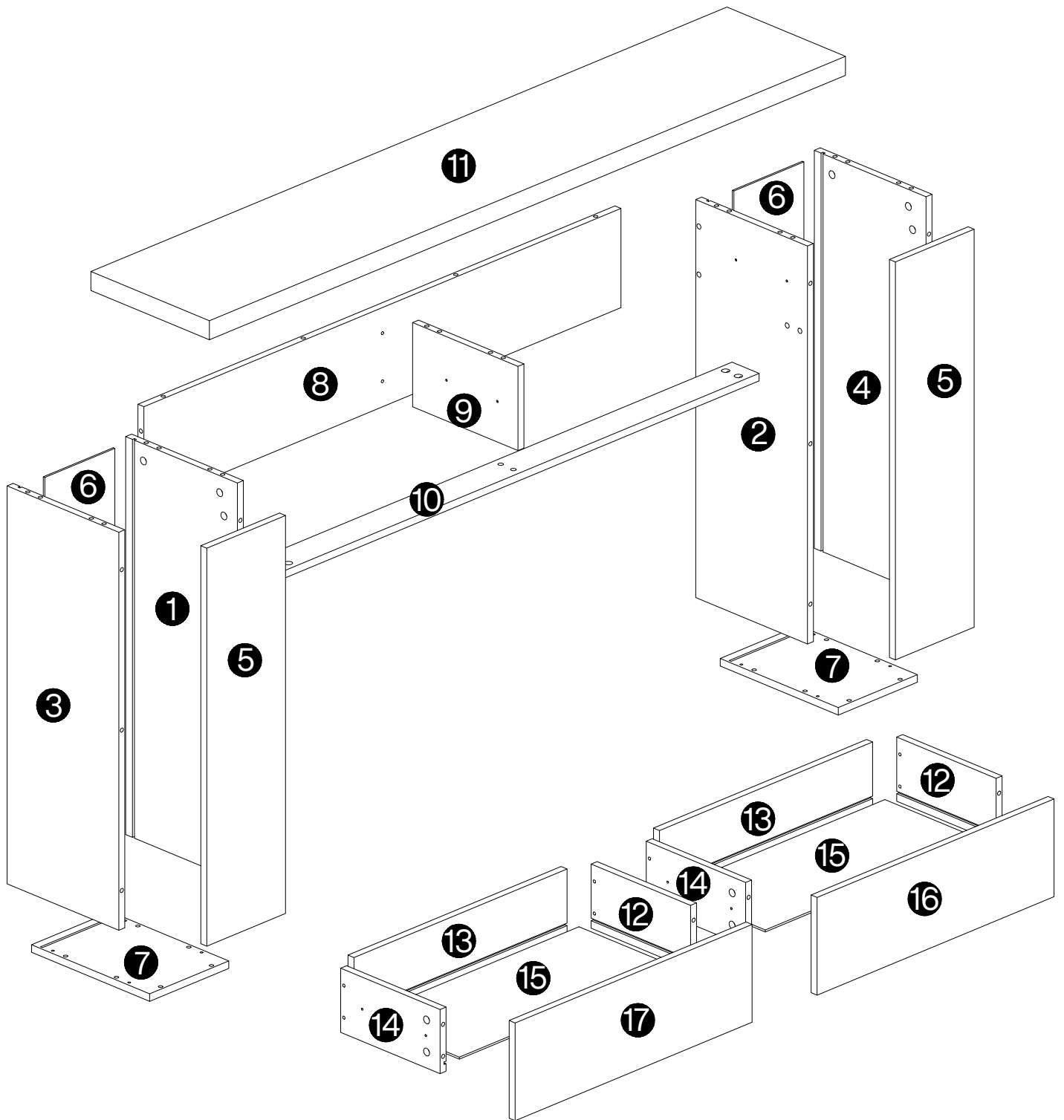

⚠ Caution

Make sure all parts are included. Most board parts are labeled or stamped on the raw edge. Contact us for a free replacement if you encounter any damaged or missing parts.



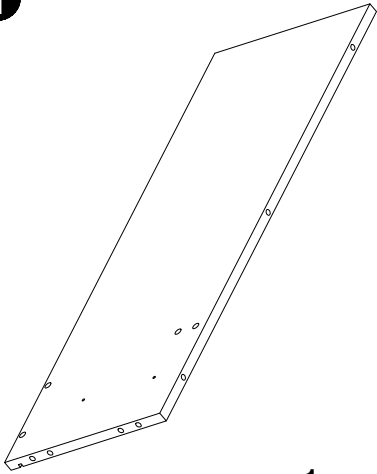
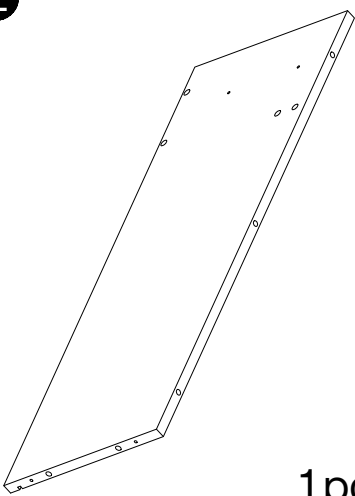
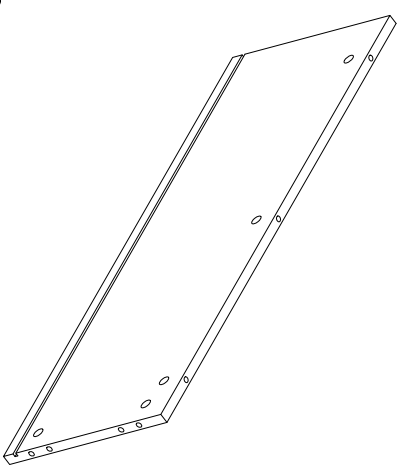
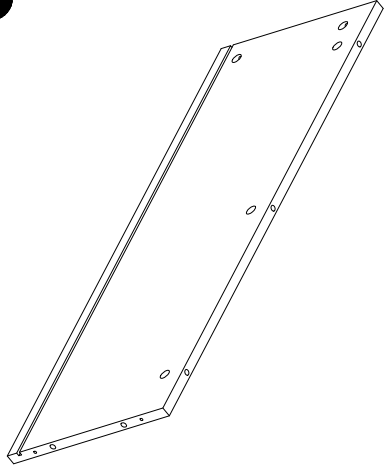
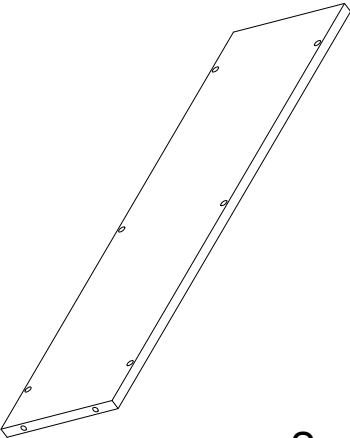
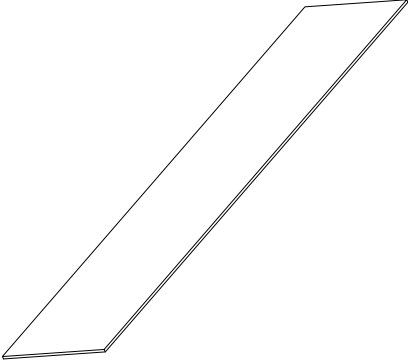
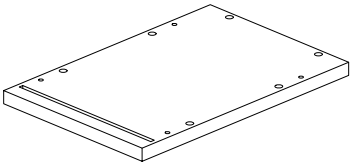
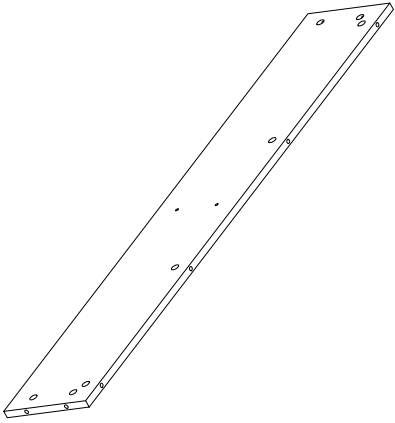
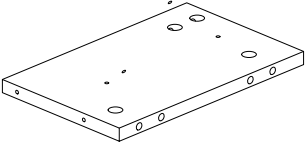

Parts List

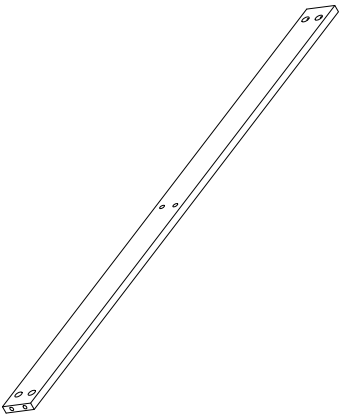
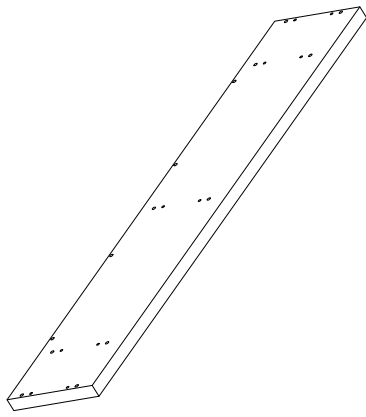
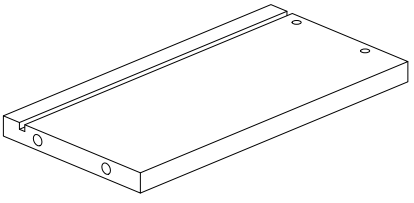
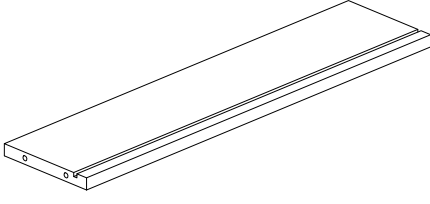
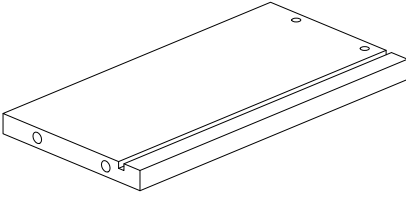
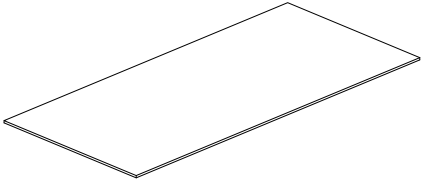
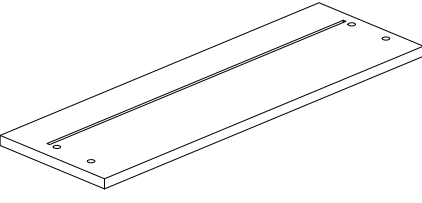
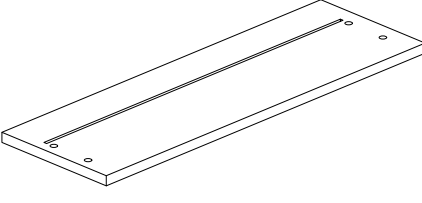
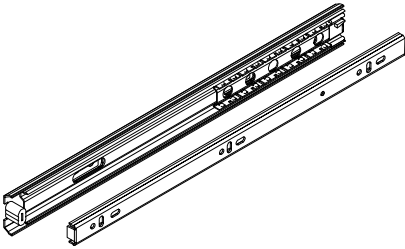

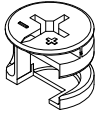
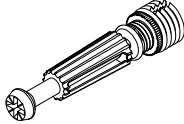
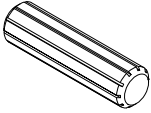

<p>1</p>  <p>1 pc</p>	<p>2</p>  <p>1 pc</p>	<p>3</p>  <p>1 pc</p>
<p>4</p>  <p>1 pc</p>	<p>5</p>  <p>2 pcs</p>	<p>6</p>  <p>2 pcs</p>
<p>7</p>  <p>2 pcs</p>	<p>8</p>  <p>1 pc</p>	<p>9</p>  <p>1 pc</p>

Parts List

<p>10</p>  <p>1 pc</p>	<p>11</p>  <p>1 pc</p>	<p>12</p>  <p>2 pcs</p>
<p>13</p>  <p>2 pcs</p>	<p>14</p>  <p>2 pcs</p>	<p>15</p>  <p>2 pcs</p>
<p>16</p>  <p>1 pc</p>	<p>17</p>  <p>1 pc</p>	<p>18</p>  <p>2 sets</p>

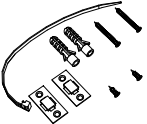
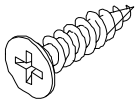
Hardware List

A	B	C	D	E	F
					
Ø15x12mm	M6x40mm	M8x30mm	M6x10mm	M5x38mm	M3
44 pcs	44 pcs	22 pcs	8 pcs	18 pcs	1 pc

G	H	I	J	K	
					
	M3.5x14mm		Ø22	M4	
2 pcs	24 pcs	8 pcs	12 pcs	1 pc	

Installation of Cams and Pins

Step 1-2: Align the plastic part with the mounting hole and press it in. If you can't press it in, loosen the screw counter clockwise or completely remove the screw from the plastic part and try again.
Step 3-4: After pressing the plastic part into place, use a screwdriver to tighten the screw clockwise.

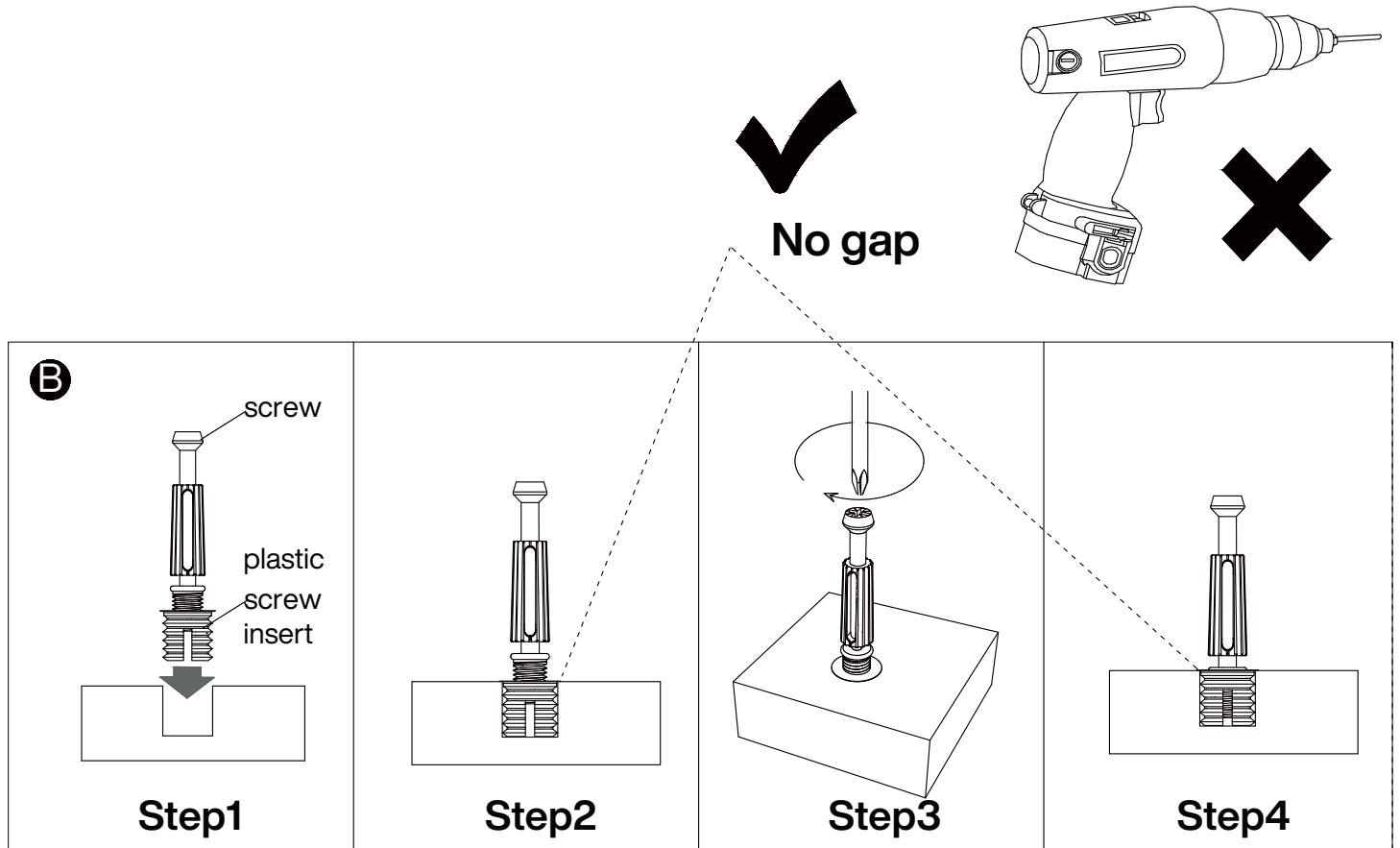

Screw the pin into the hole. Set the cams correctly by aligning the head of the cams with the lock pins. Lock the cam by turning the cam head with a screwdriver until it is tightened. Please do not use an electric screwdriver to assemble the unit.

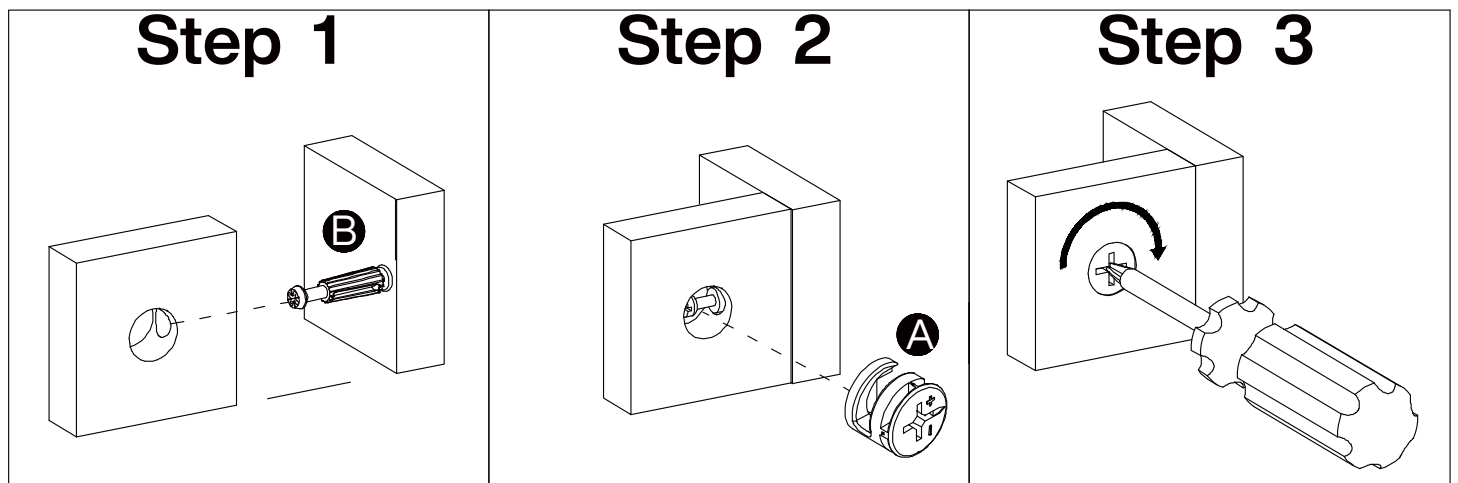

Please split component "18" into "18-1" and "18-2" before assembling the slide and then proceed to the next step of assembly

Step 1

Pull apart component "18" to each side, and then gently push up the lever of component "18-2"

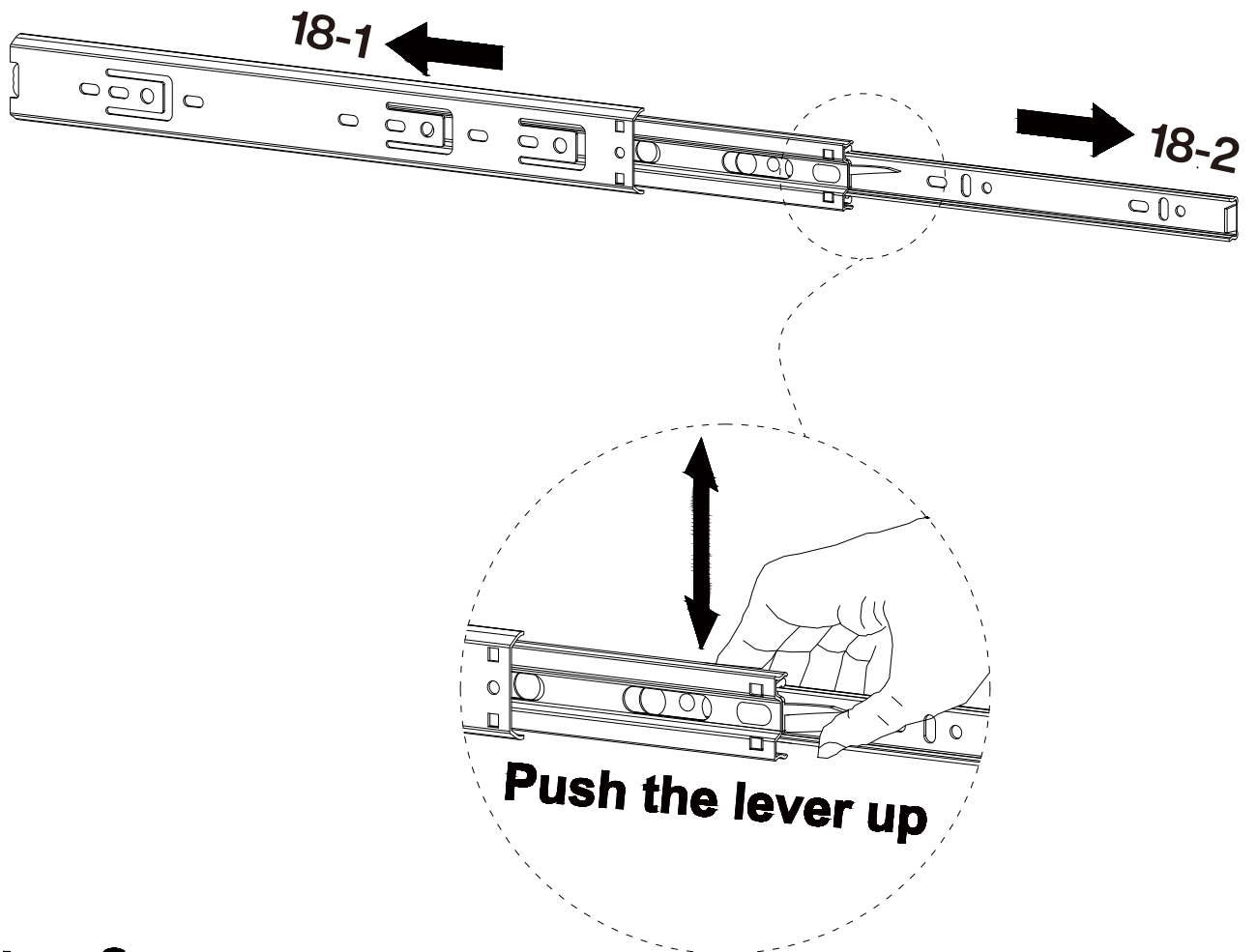

Step 2 Split component "18-1" and "18-2"

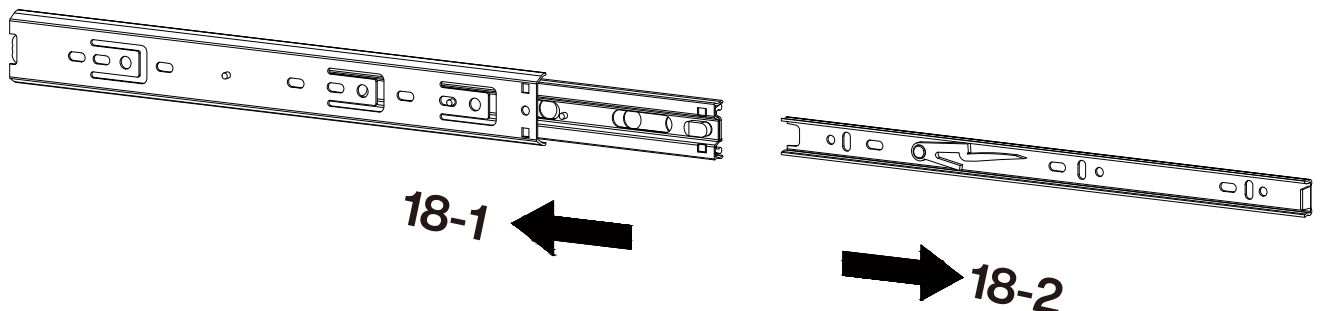

1

18

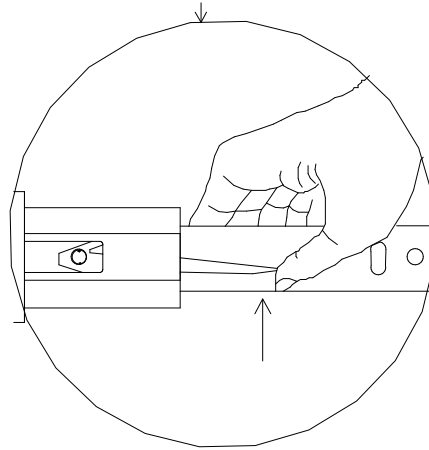
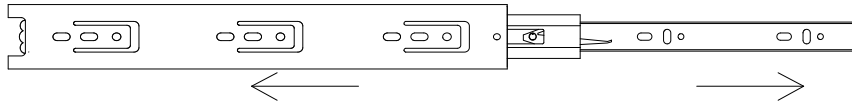

18-1

18-2

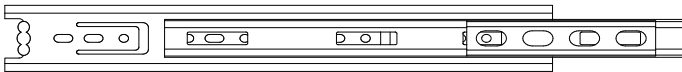

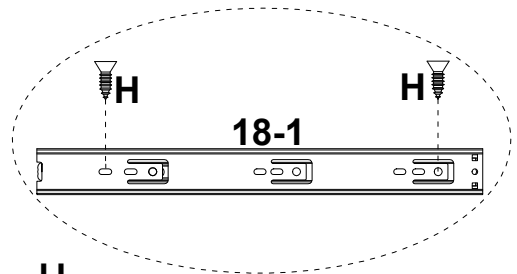
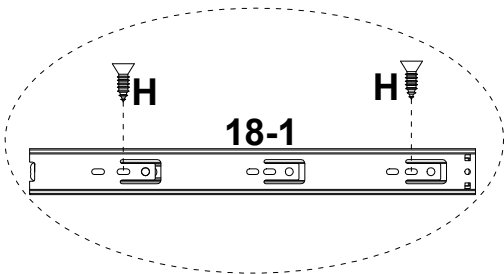

2

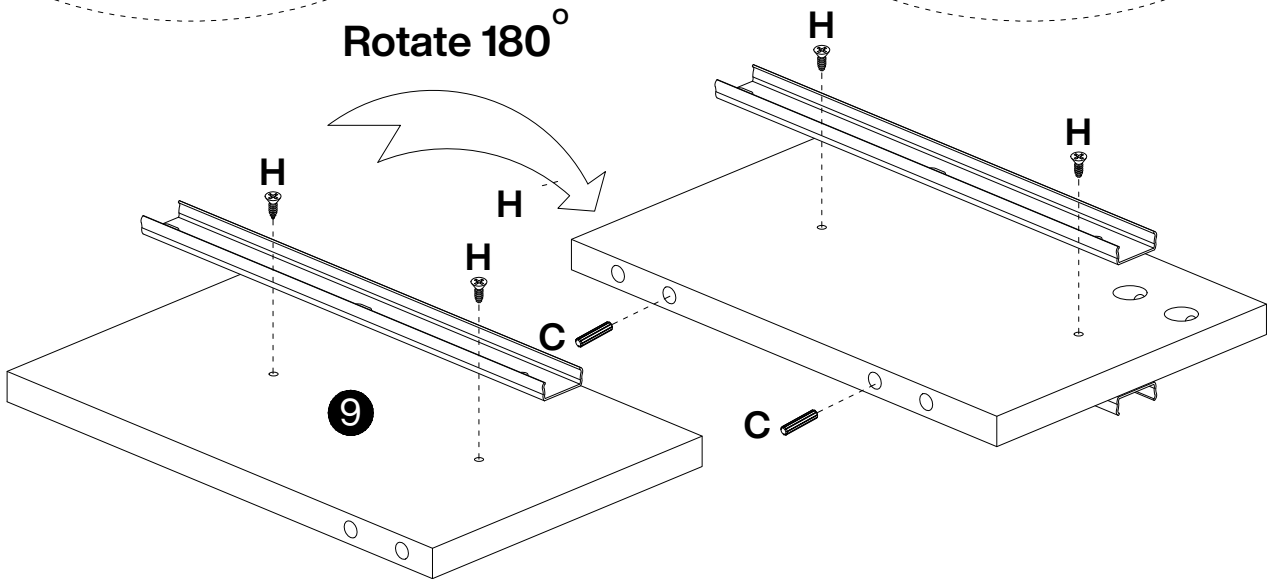

Rotate 180°



C	H	18-1
		
M8x30mm 2 pcs	M3.5x14mm 4 pcs	250mm 2 pcs

3

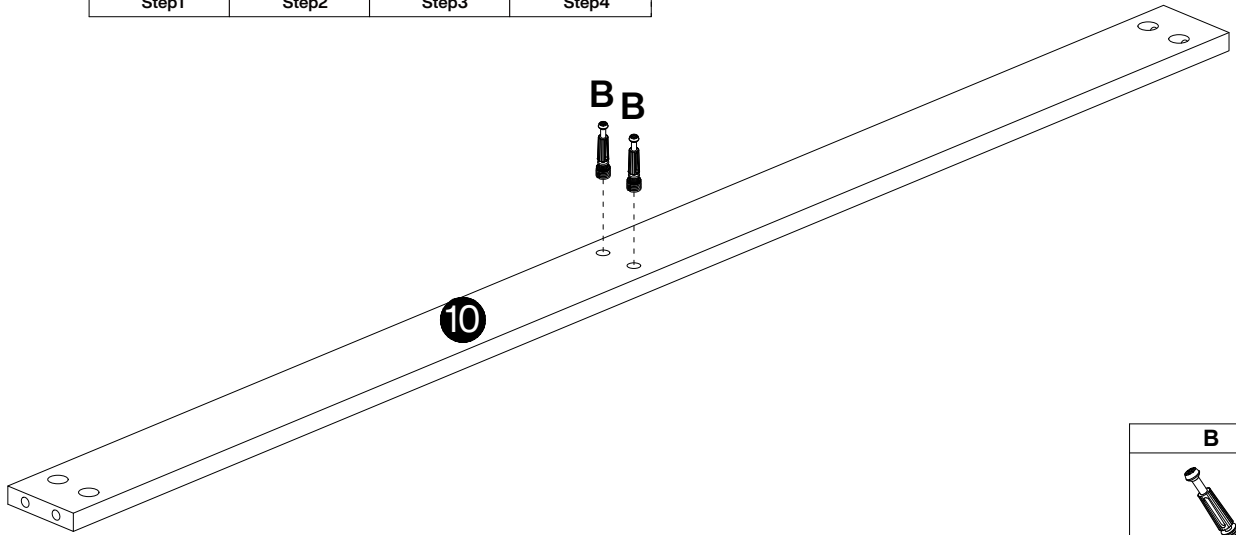
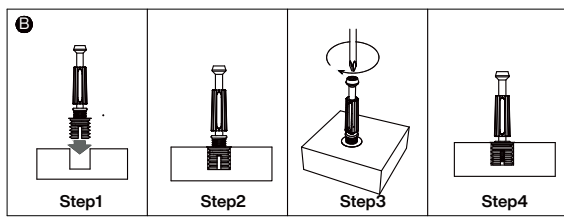

B
M6x40mm
2 pcs



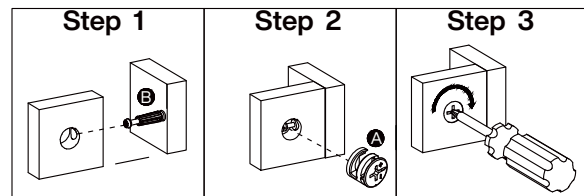
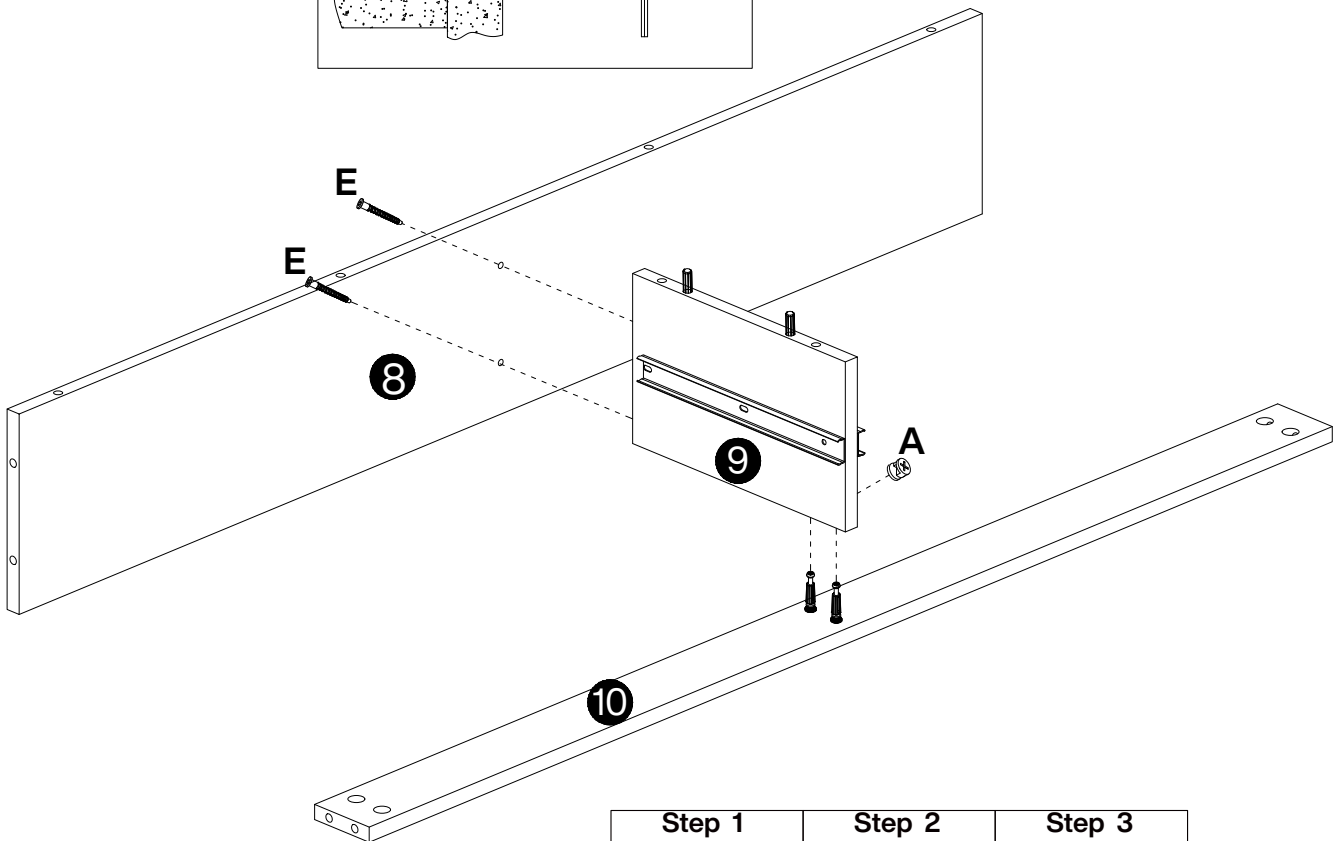
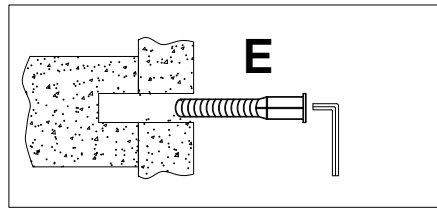

4

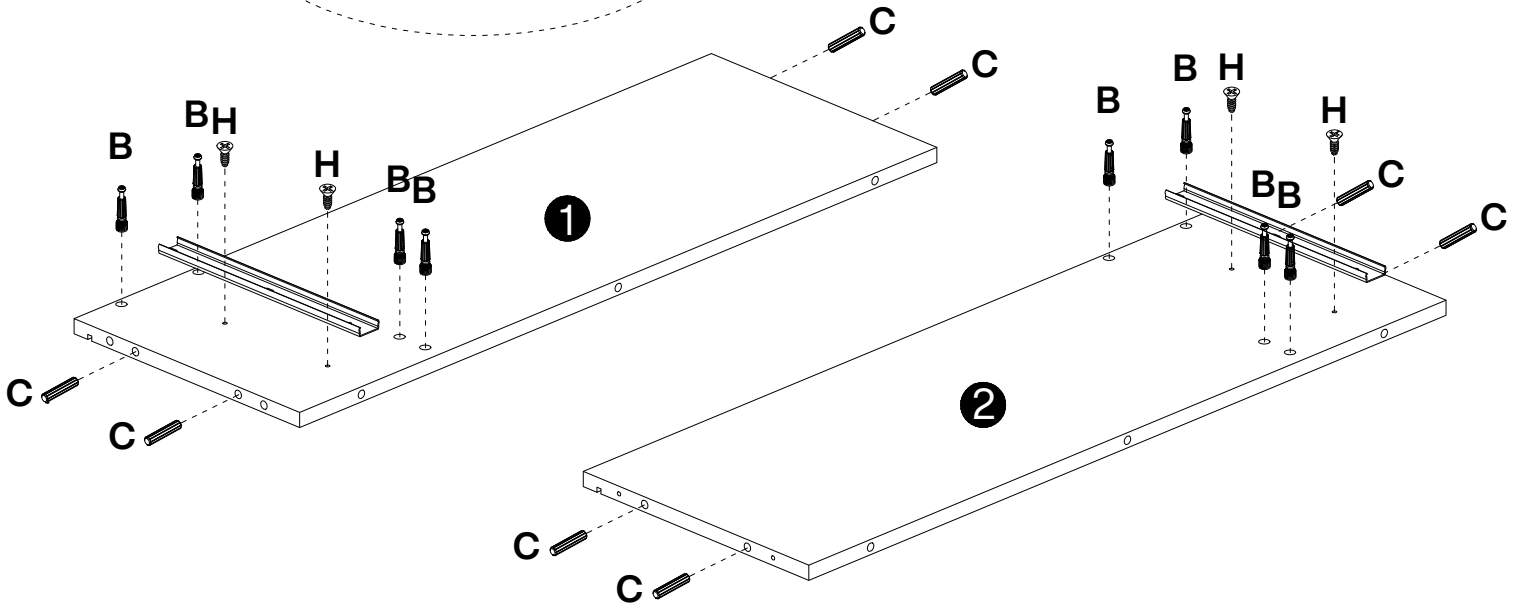
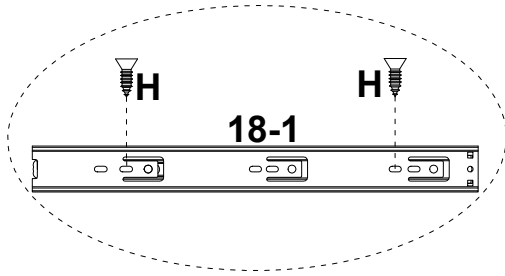

A	E	F
Ø15x12mm	M5x38mm	M3
2 pcs	2 pcs	1 pc



5

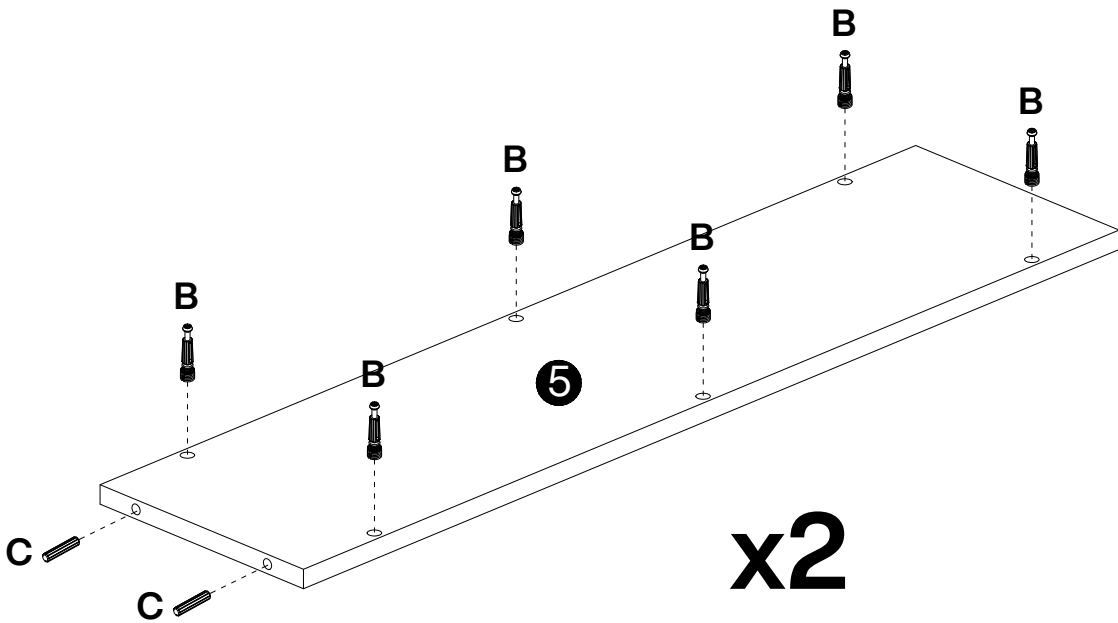

B	C	H	18-1
			
M6x40mm	M8x30mm	M3.5x14mm	250mm
8 pcs	8 pcs	4 pcs	2 pcs

6



B	C
	
M6x40mm	M8x30mm
12 pcs	4 pcs

7

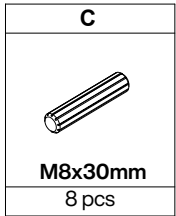
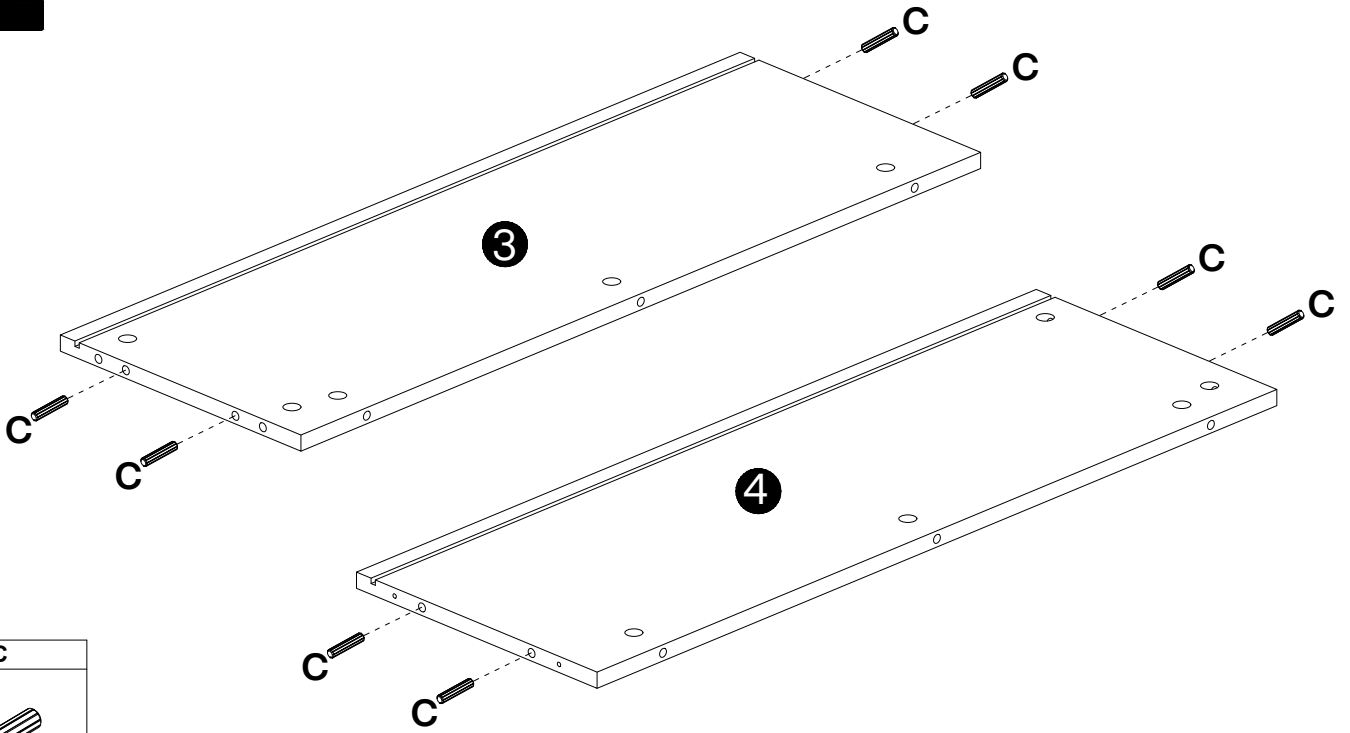

8

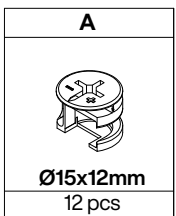
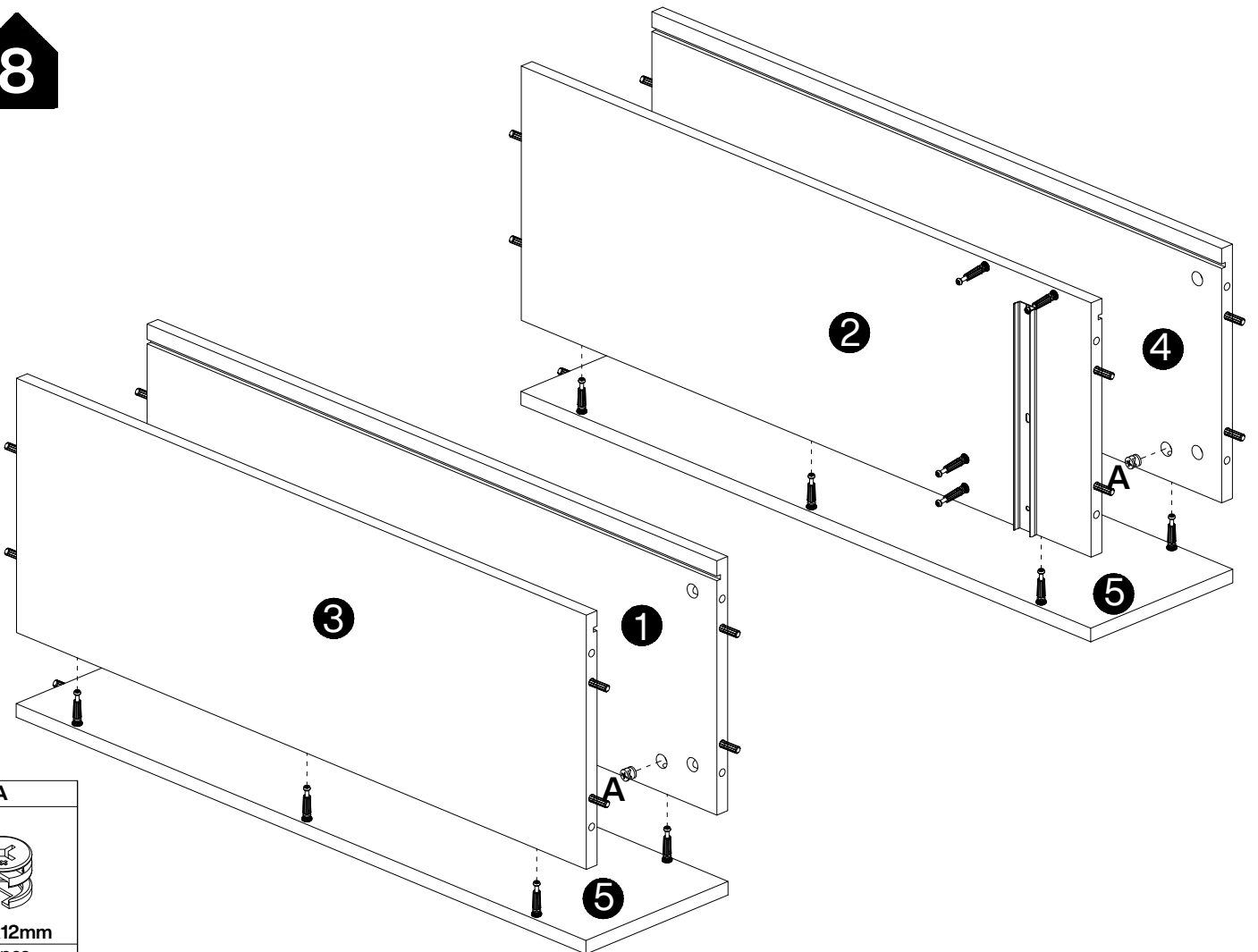

9

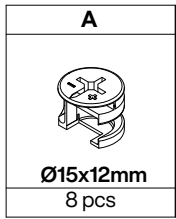
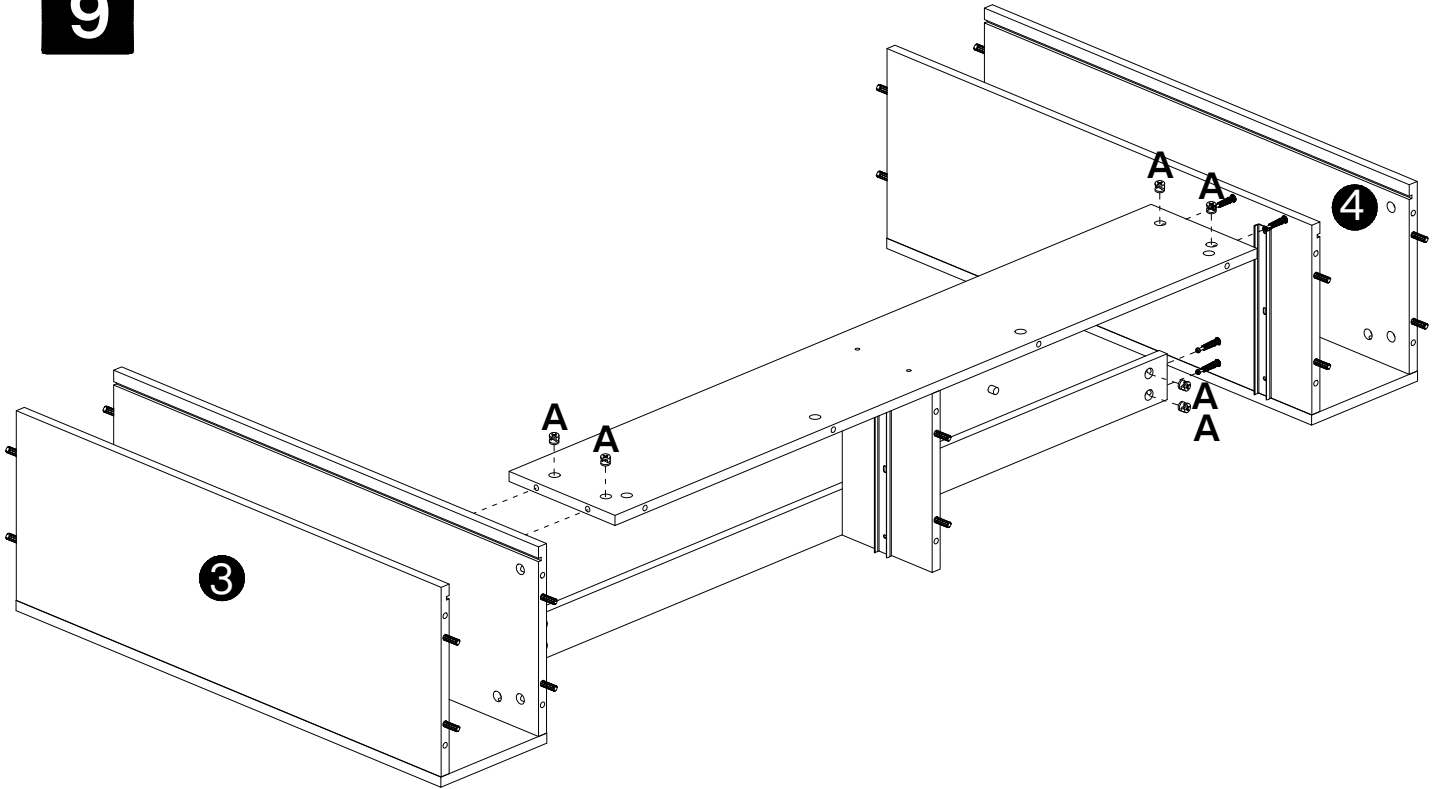

10

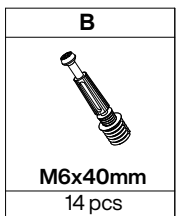
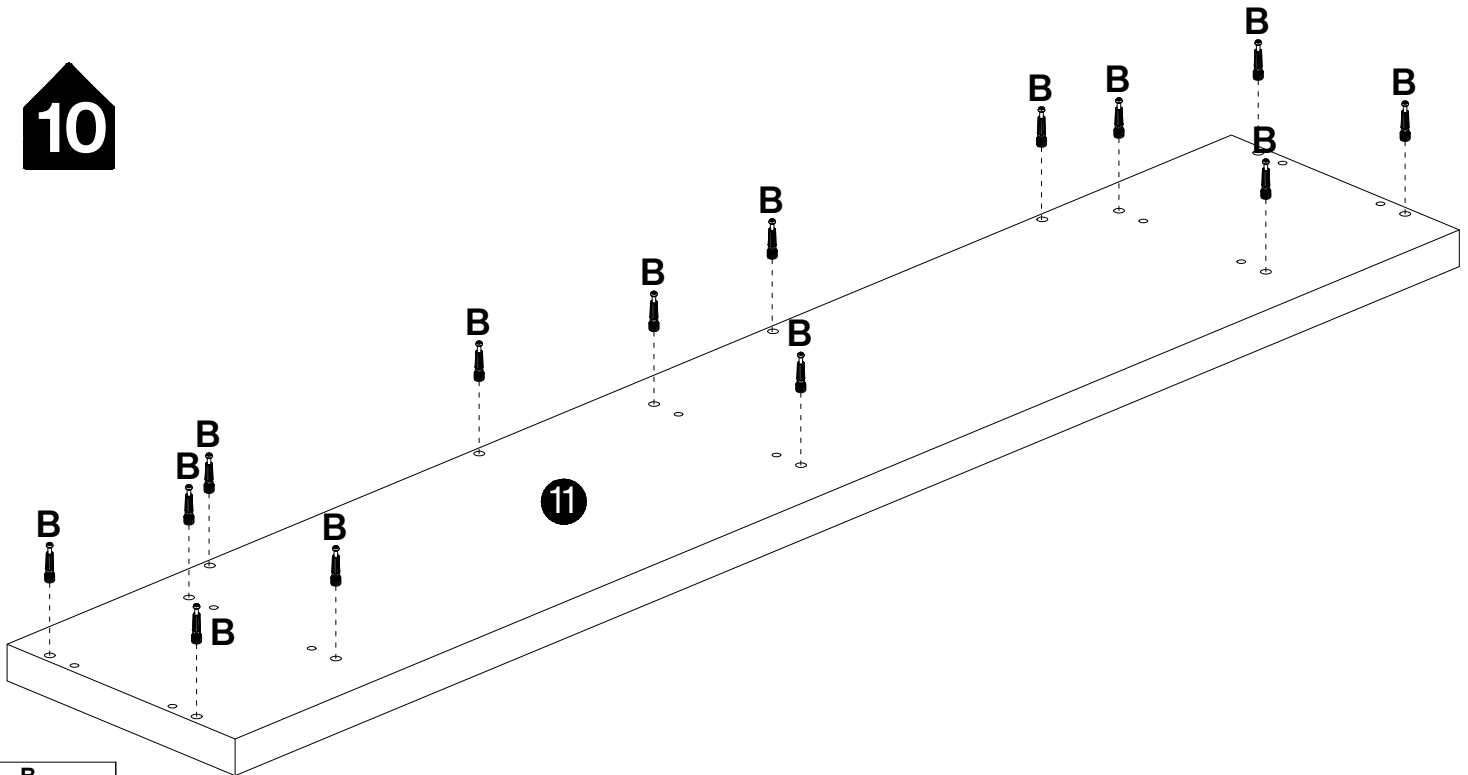

11

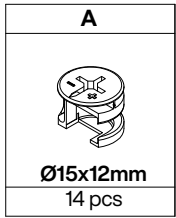
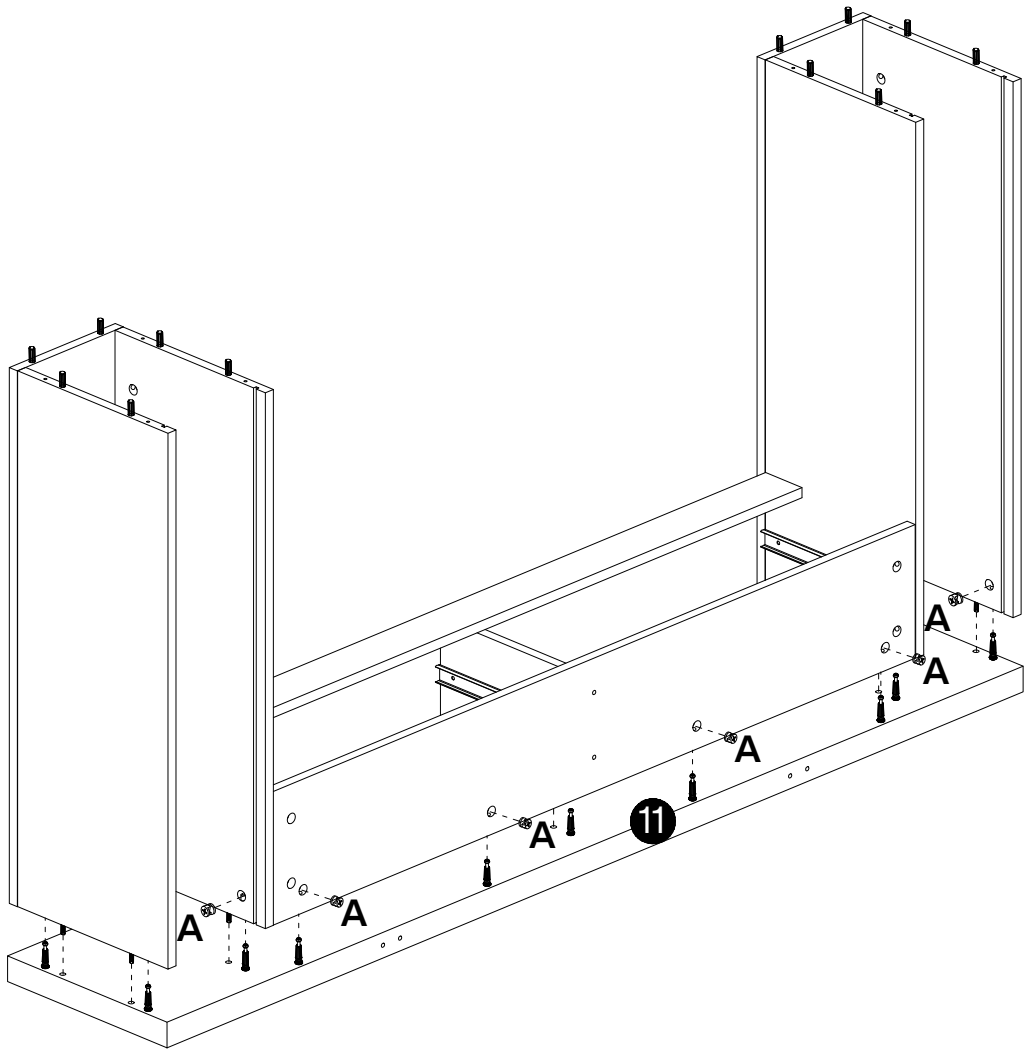

12

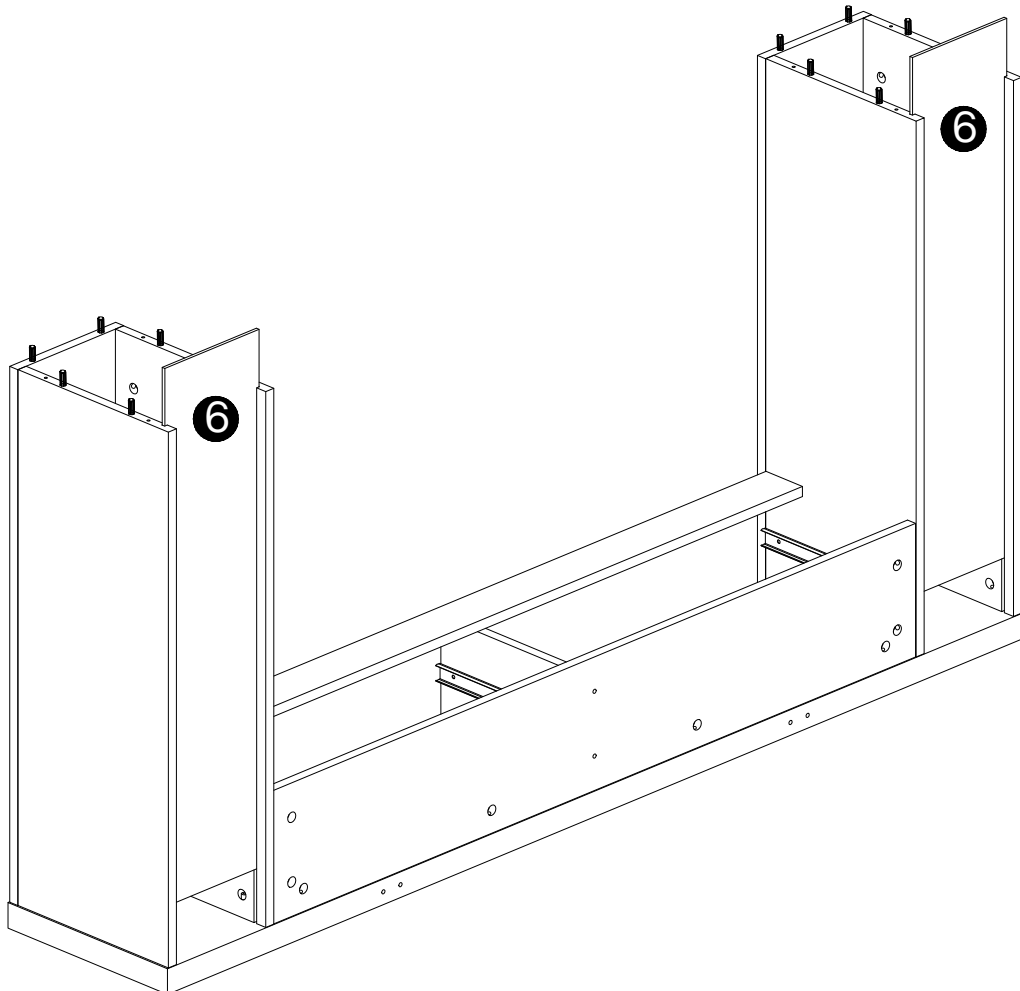

13

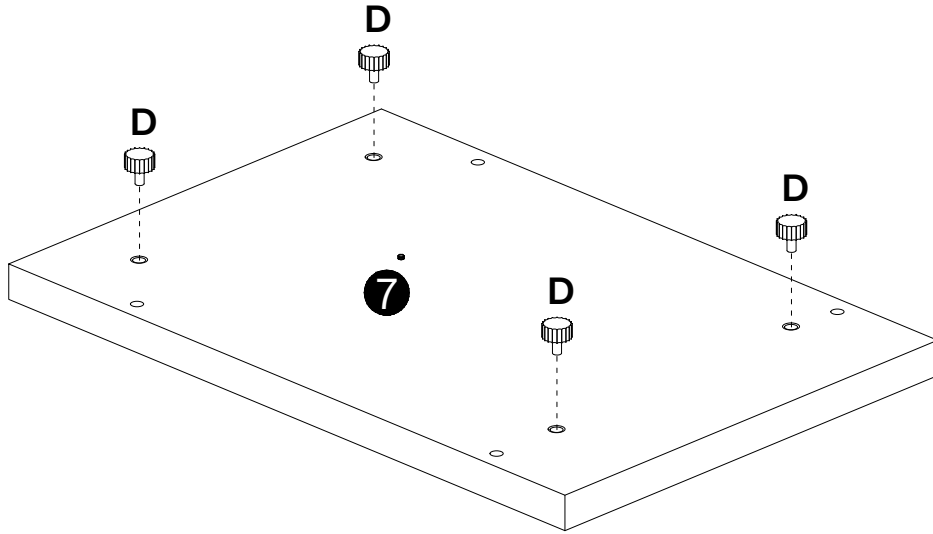

x2

D

M6x10mm 8 pcs

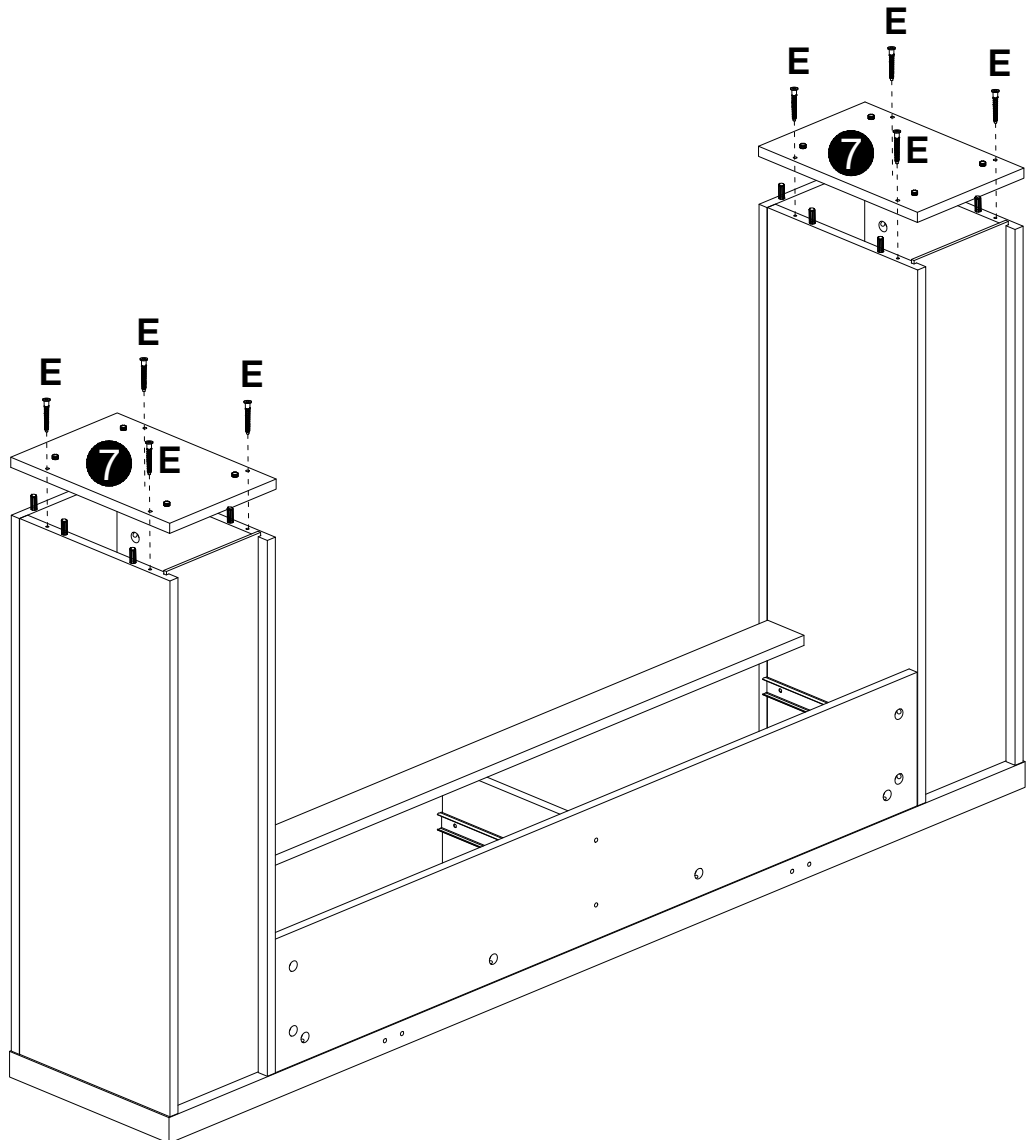

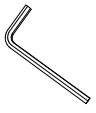
14

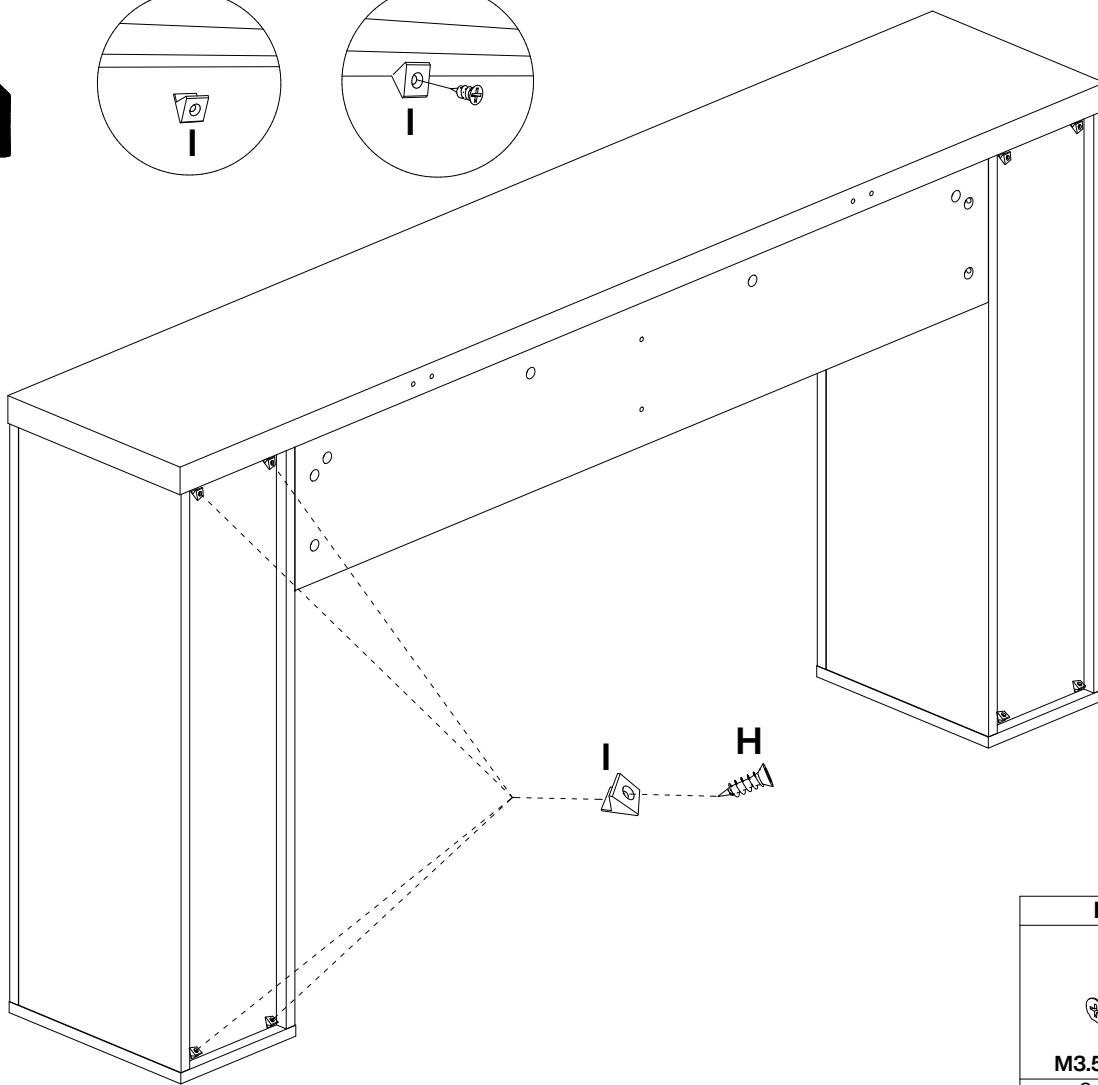
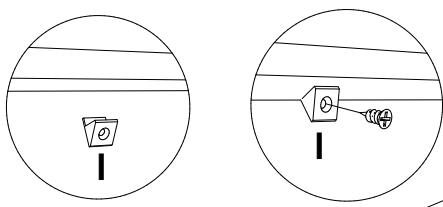

E	F
	
M5x38mm 8 pcs	M3 1 pc



15



H	I
	
M3.5x14mm	
8 pcs	8 pcs

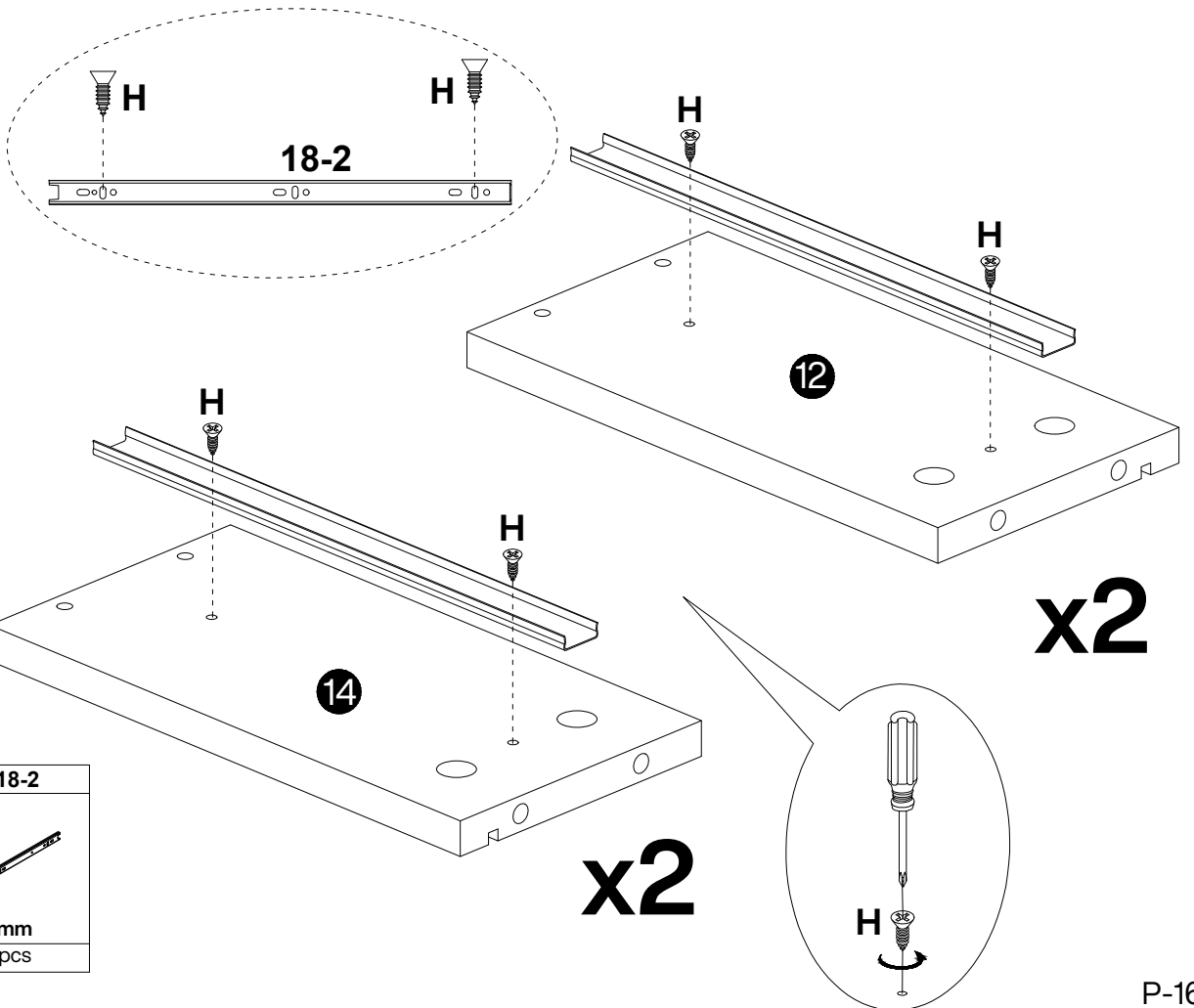

16

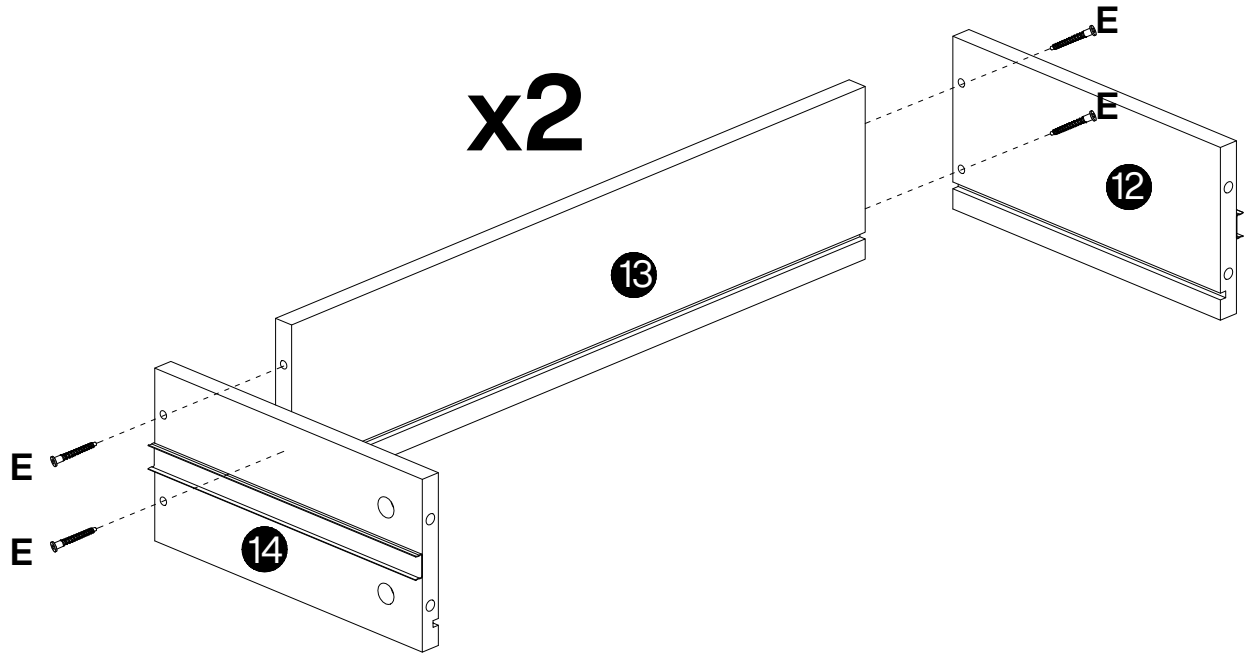

H	18-2
	
M3.5x14mm	250mm
8 pcs	4 pcs

17



E	F
	
M5x38mm 8 pcs	M3 1 pc

18

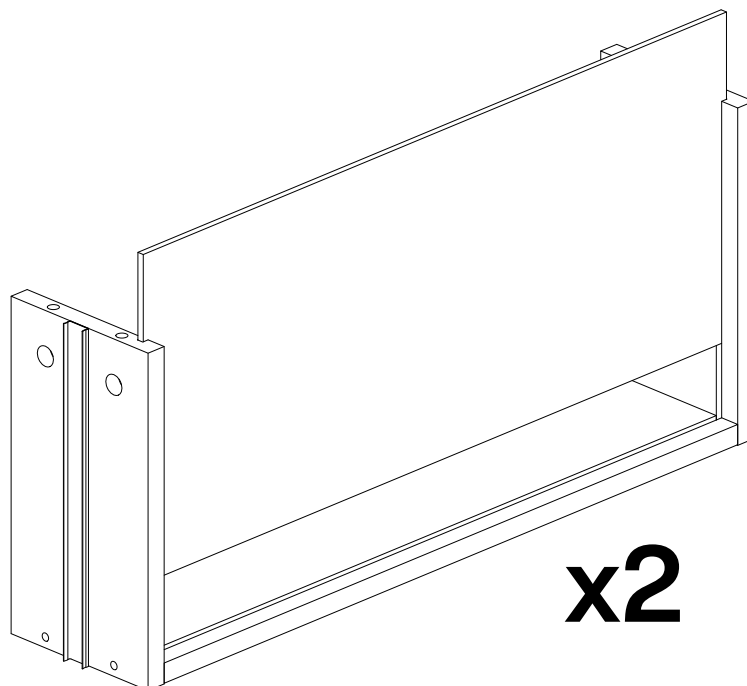

19

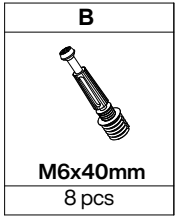
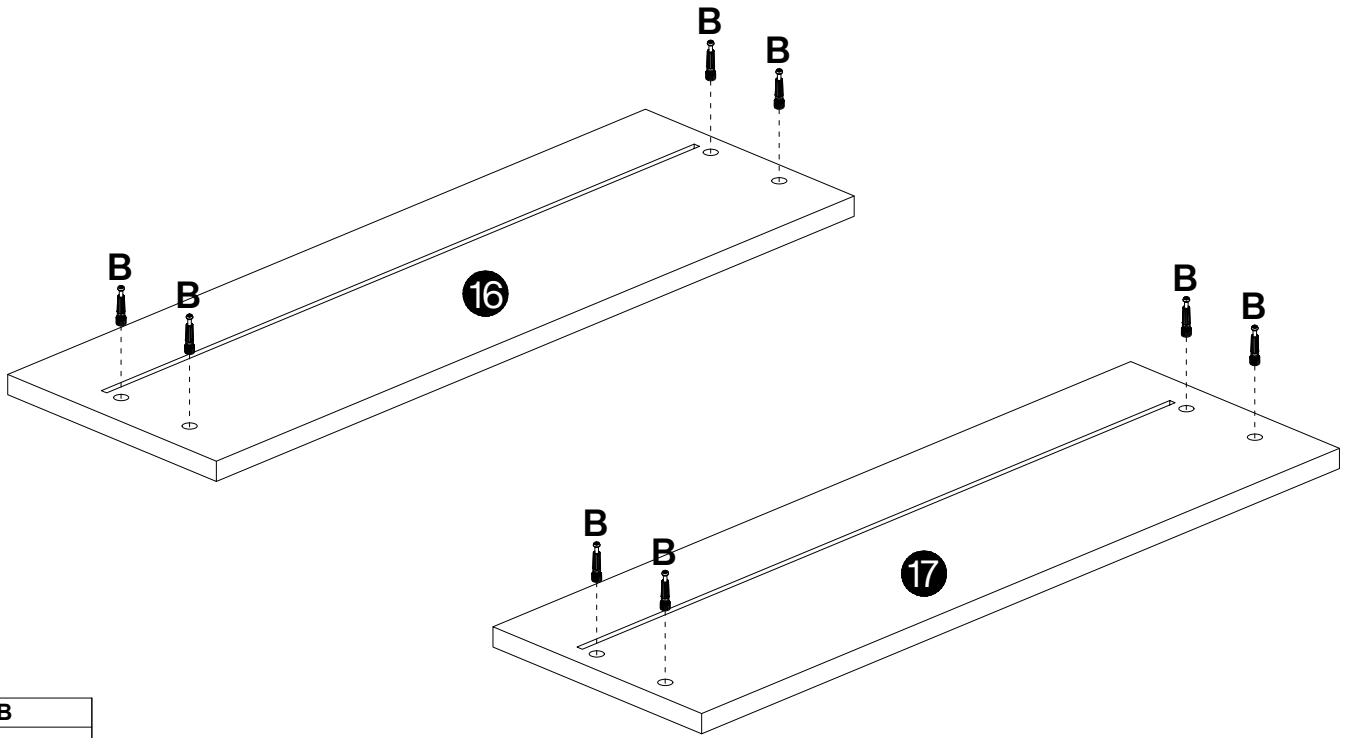

20

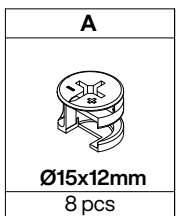
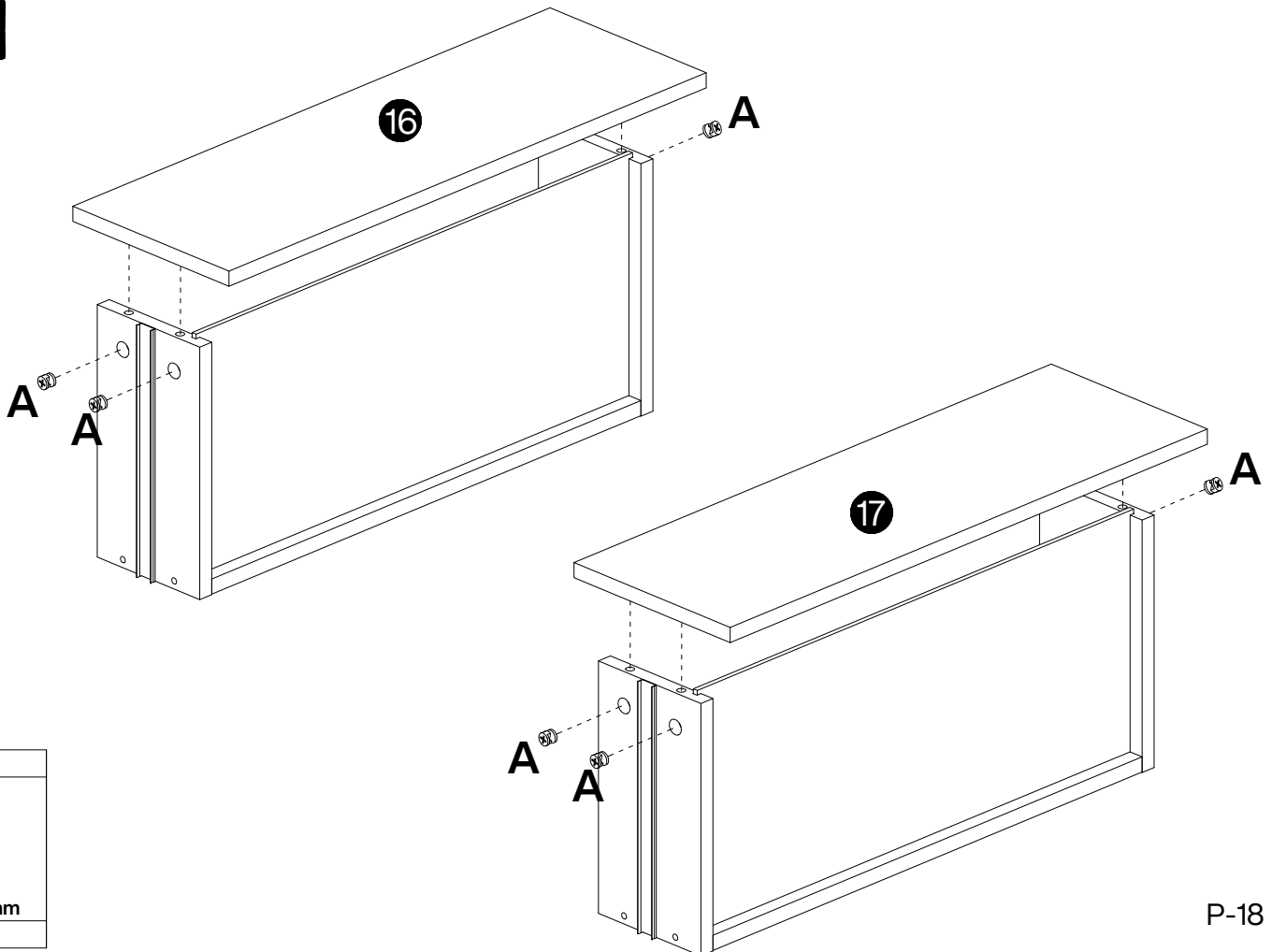

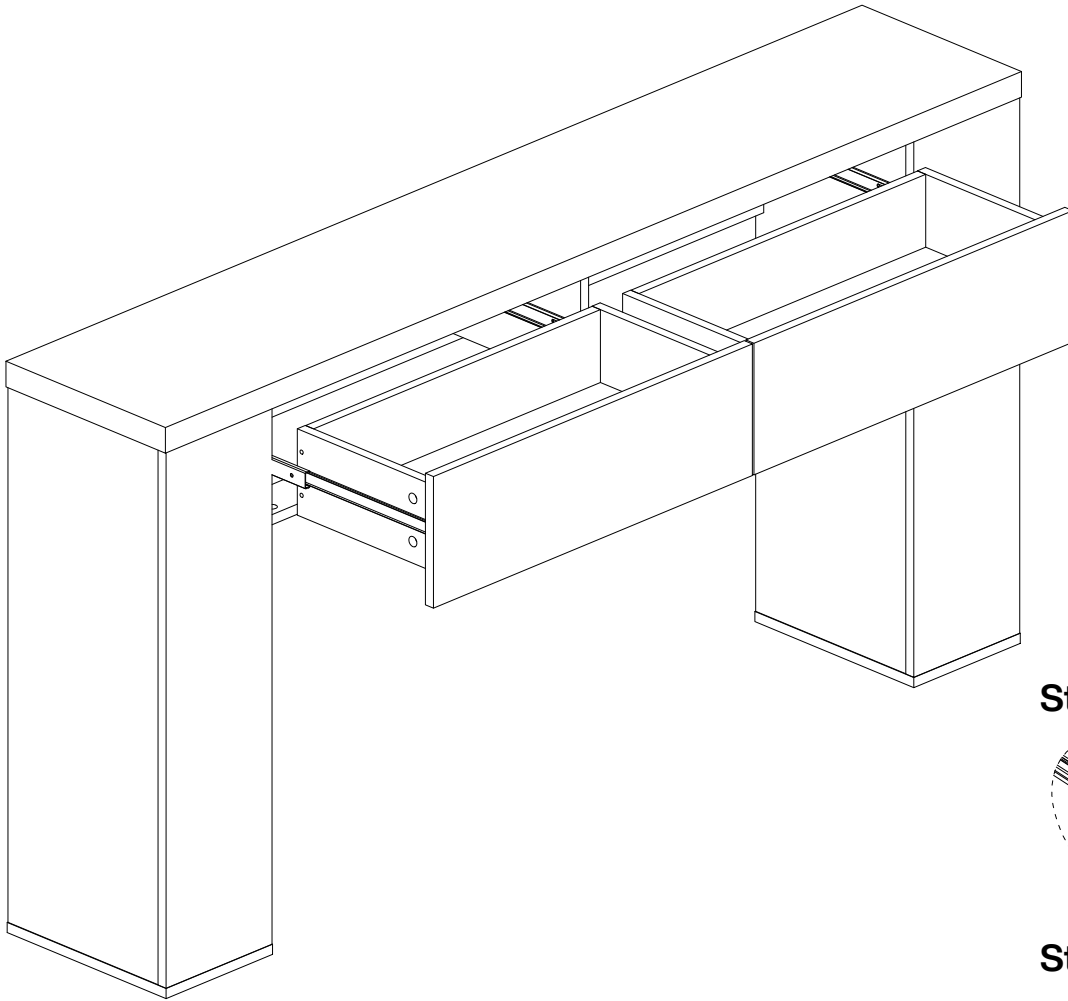

Step 1

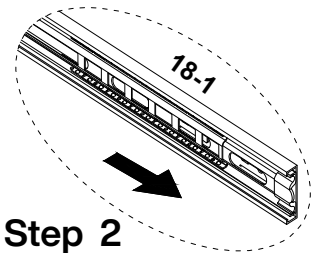

Step 2

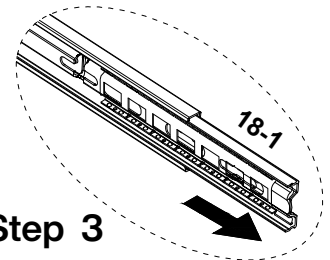

Step 3

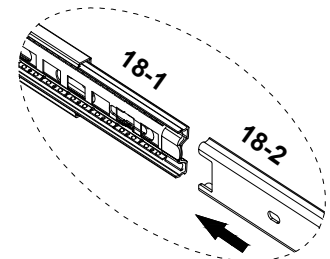

Before installation, slide the inner iron pieces of #18-1 to the outermost side. Then align it with #18-2 and gently push it inward to complete the slide installation.

22

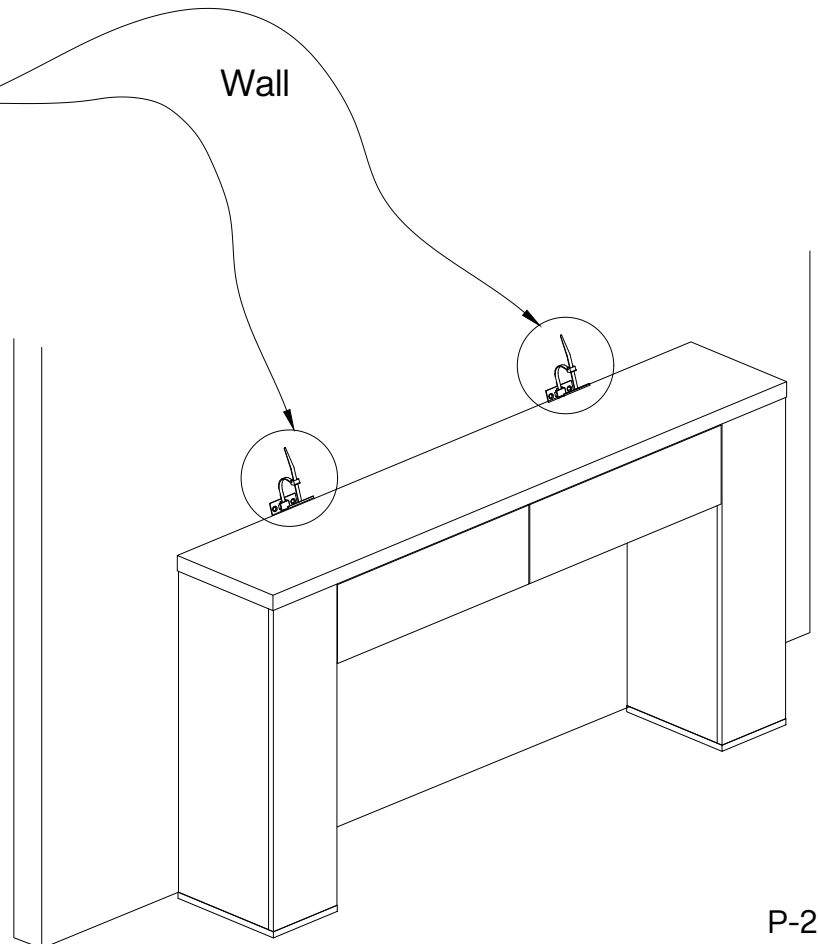
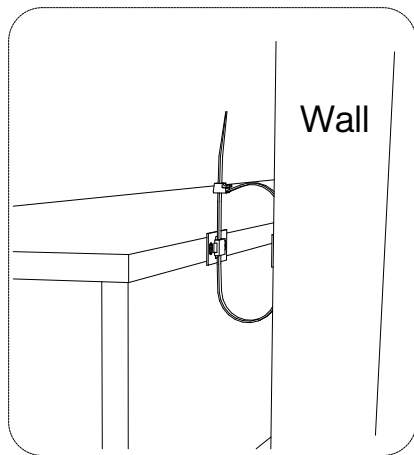
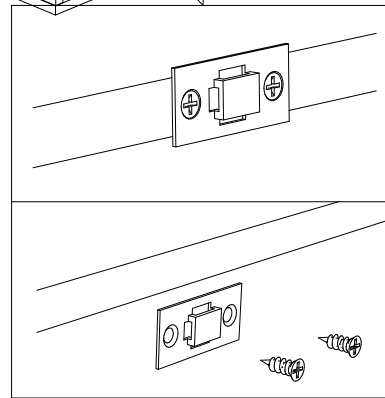
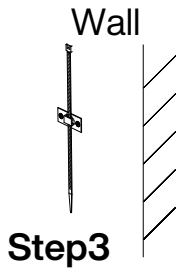
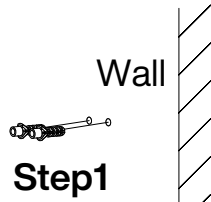
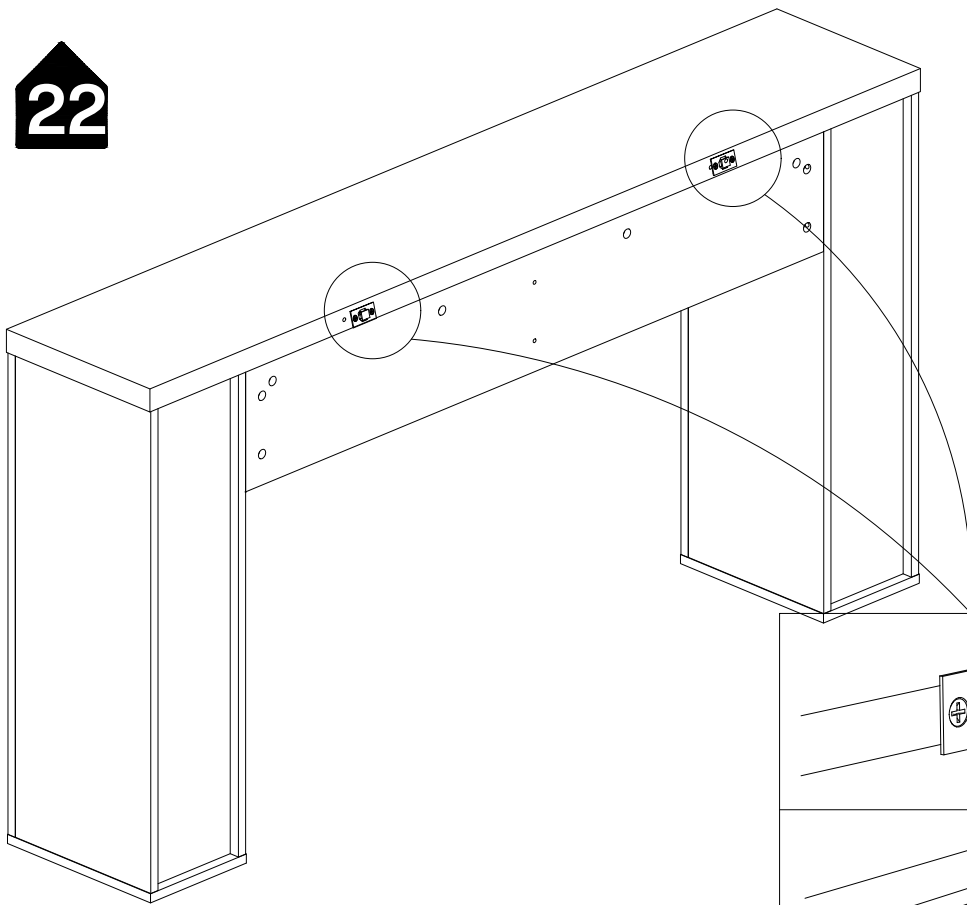

Thank you for your support !

