

ASSEMBLY INSTRUCTIONS



**IMPORTANT
PLEASE READ BEFORE YOU CONTINUE FURTHER**

WARNING AND INSTRUCTIONS

- PLEASE KEEP THE ORIGINAL PACKAGING UNTIL THE ITEM IS FULLY ASSEMBLED AND IN PLACE. IN THE UNLIKELY EVENT THAT YOU NEED TO RETURN YOUR PRODUCT, IT MUST BE RETURNED IN ITS ORIGINAL PACKAGING TO AVOID FURTHER DAMAGE. FAILURE TO COMPLY TO THESE PROCEDURES, NO RETURN'S WILL BE ACCEPTED.
- **IMPORTANT: RETAIN THESE INSTRUCTIONS FOR FUTURE REFERENCE.**
- DUE TO THE SIZE OF THIS PRODUCT WE RECOMMEND THAT IT IS ASSEMBLED IN THE ROOM INTENDED FOR USE.
- WHEN YOU ARE READY TO START, MAKE SURE THAT YOU HAVE THE RIGHT TOOLS, PLENTY OF SPACE AND A CLEAN, DRY AREA FOR ASSEMBLY.
- UNWRAP ALL PACKAGING MATERIALS AND PLACE THE COMPONENTS ON TOP OF THE CARTON BOX OR ON A CLEAN FLOOR TO PREVENT IT FROM SCRATCHING.
- CHECK THE PACK AND MAKE SURE YOU HAVE ALL THE PARTS LISTED.
- ENSURE THAT THIS PRODUCT IS FULLY ASSEMBLED AS ILLUSTRATED BEFORE USE.
- TOOLS NOT INCLUDED.
- CHECK ALL SCREWS OR BOLTS ARE TIGHTENED AND INSPECT REGULARLY.
- THIS PRODUCT SHOULD ONLY BE USED ON FIRM LEVEL GROUND.
- KEEP SMALL PART OUT OF REACH OF CHILDREN.
- MAKE SURE THE LEGS REMAIN IN CONTACT WITH THE GROUND.
- DO NOT USE POWER TOOLS TO CONSTRUCT THIS PRODUCT.
- DO NOT TIGHTENED SCREWS UNTIL FULLY ASSEMBLED.
- DO NOT OVER TIGHTENED SCREWS OR BOLTS.
- DO NOT USE THIS PRODUCT IF PARTS ARE MISSING, DAMAGE OR WORN.
- DO NOT SIT AND STAND ON THE PRODUCT.
- TO CLEAN WIPE WITH A SPONGE AND WARM SOAPY WATER. DO NOT USE SOLVENT BASED CLEANERS OR DETERGENTS AS THEY CAN BLEACH OR DAMAGE THE PRODUCT.
- NEVER USE SCOURERS, ABRASIVES OR CHEMICAL CLEANERS.

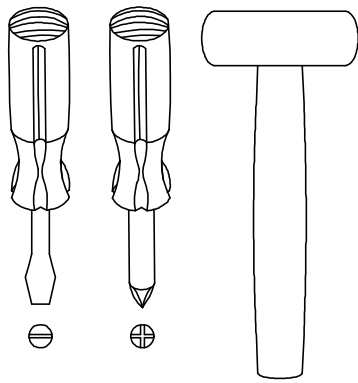

(Tools not provided)

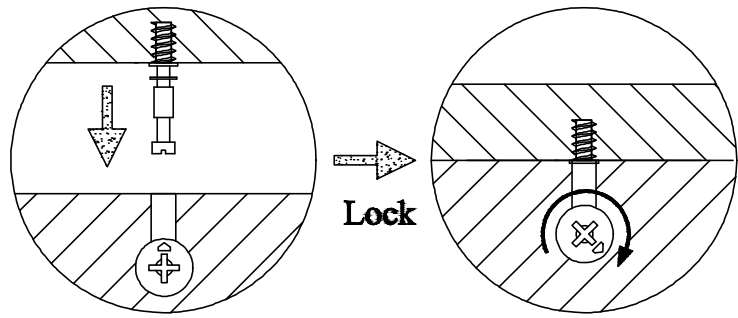

Use a flat blade screwdriver to tighten the cam nuts. A quarter turn clockwise is all that is needed.

This is how a cam nut works.....

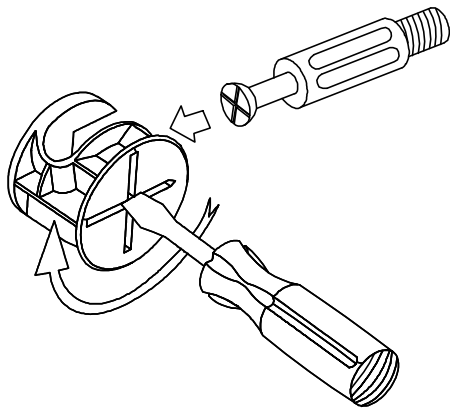

The head of the cam bolt goes into the open mouth of the cam nut. You then turn the cam nut so it tightens over the bolt.

TWO PERSONS REQUIRED TO ASSEMBLE THIS PRODUCT

1. Please check that you have all the parts listed before you start assembling. If you do find that something is missing, do not continue assembly. Please contact your supplier immediately.
2. Lay out all of the components on a soft surface as if you were preparing to do a jigsaw puzzle.
3. Separate and identify each component from the hardware pack and rest each one in its proper location before fastening.

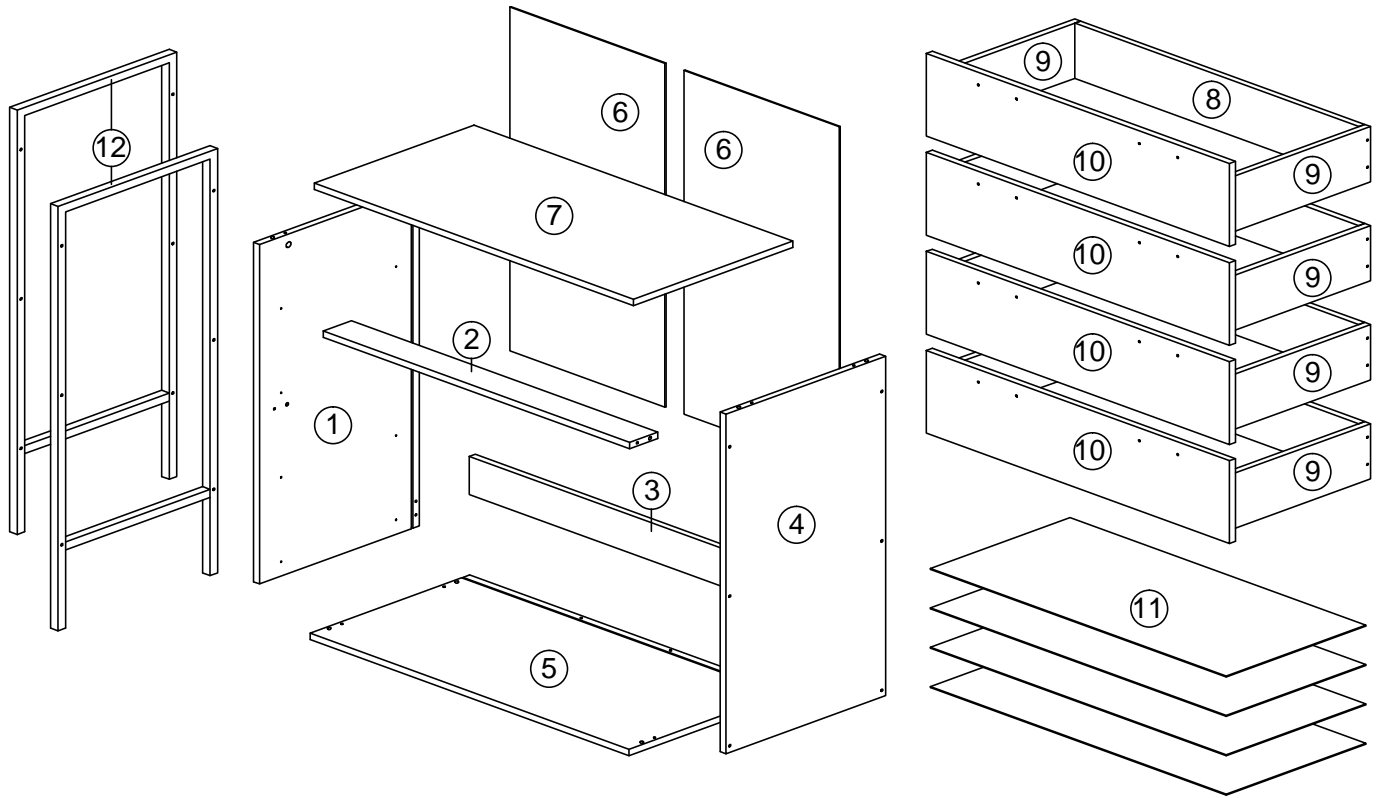

PARTS LIST

NO.	PARTS					QTY
1	800	X	399	X	15	1 PC
2	768	X	70	X	15	1 PC
3	768	X	90	X	15	1 PC
4	800	X	399	X	15	1 PC
5	800	X	400	X	15	1 PC
6	810	X	388.5	X	2.5	2 PCS
7	800	X	400	X	15	1 PC
8	712	X	130	X	15	4 PCS
9	350	X	130	X	15	8 PCS
10	760	X	195	X	15	4 PCS
11	741	X	350	X	2.5	4 PCS
12	982	X	400	X	19	2 PCS

HARDWARE LIST

NO.	DESCRIPTION		QTY
A		WOOD DOWEL M8 x 25MM	10
B1		CAM NUT	12
B2		CAM BOLT	12
B3		CAM CAP	12
C		CB SCREW M3.5 x 16MM	56
D		CB SCREW M4 x 38MM	32
E		CSK CAP WOOD M6 x 50MM	4
F		NAIL 5/8	40
G1		HANDLE 7050-96MM	8
G2		HANDLE SCREW M4 x 19MM	16
H		HANDLE SCREW M4 x 30MM	12
I		ALLEN KEY M4	1
J		PVC CORNER L BRACKET	4
K		3MM PVH	1
L1		DRAWER SLIDE 14"	8
L2		DRAWER SLIDE 14"	8

THE USE OF POWER TOOLS TO ASSEMBLE THIS PRODUCT WILL INVALIDATE ANY CLAIM AND MAY DAMAGE THIS PRODUCT MAKING IT UNSAFE.



STEP 1

A	 WOOD DOWEL M8 x 25MM	10
---	--	----

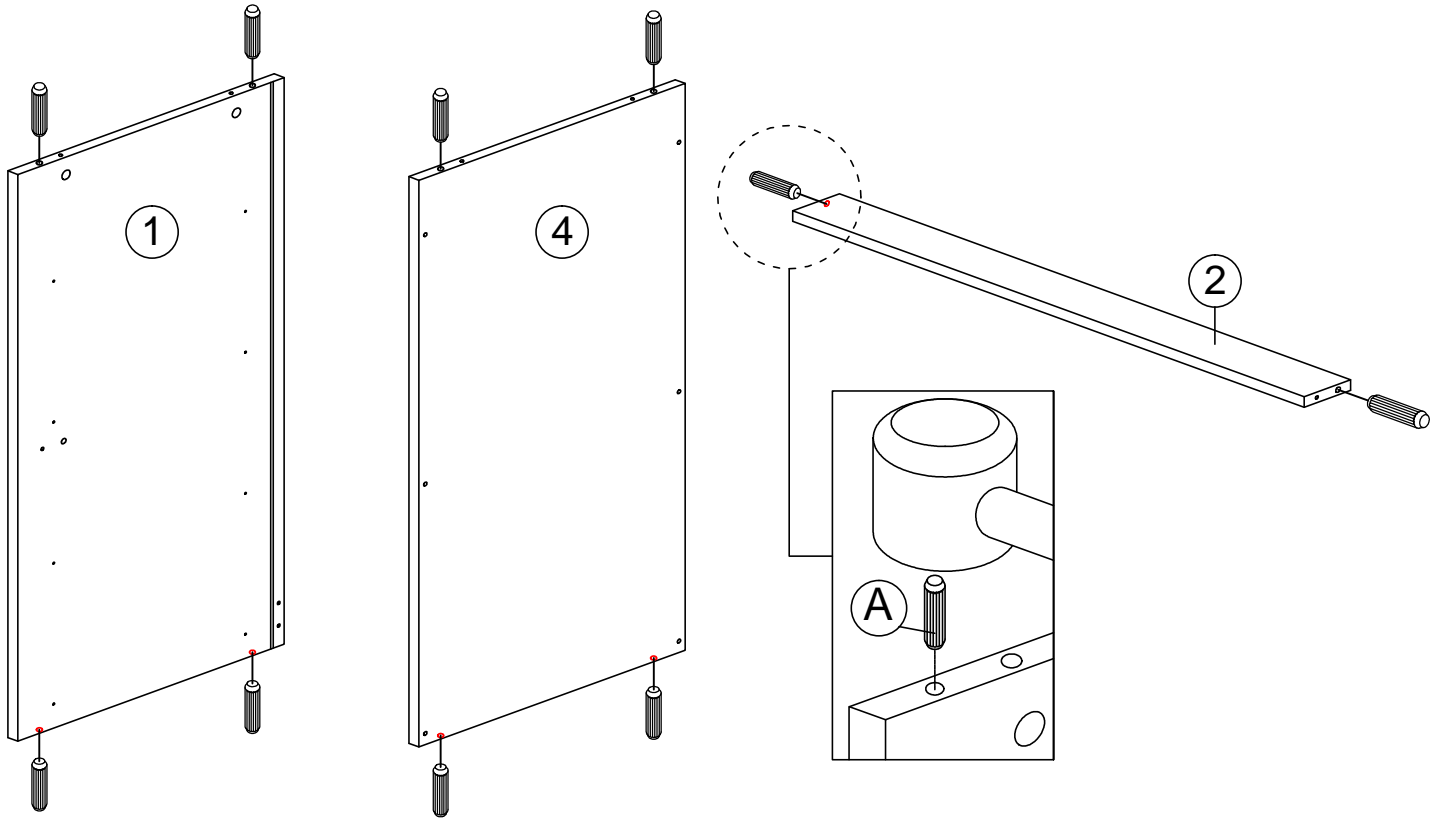

STEP 2

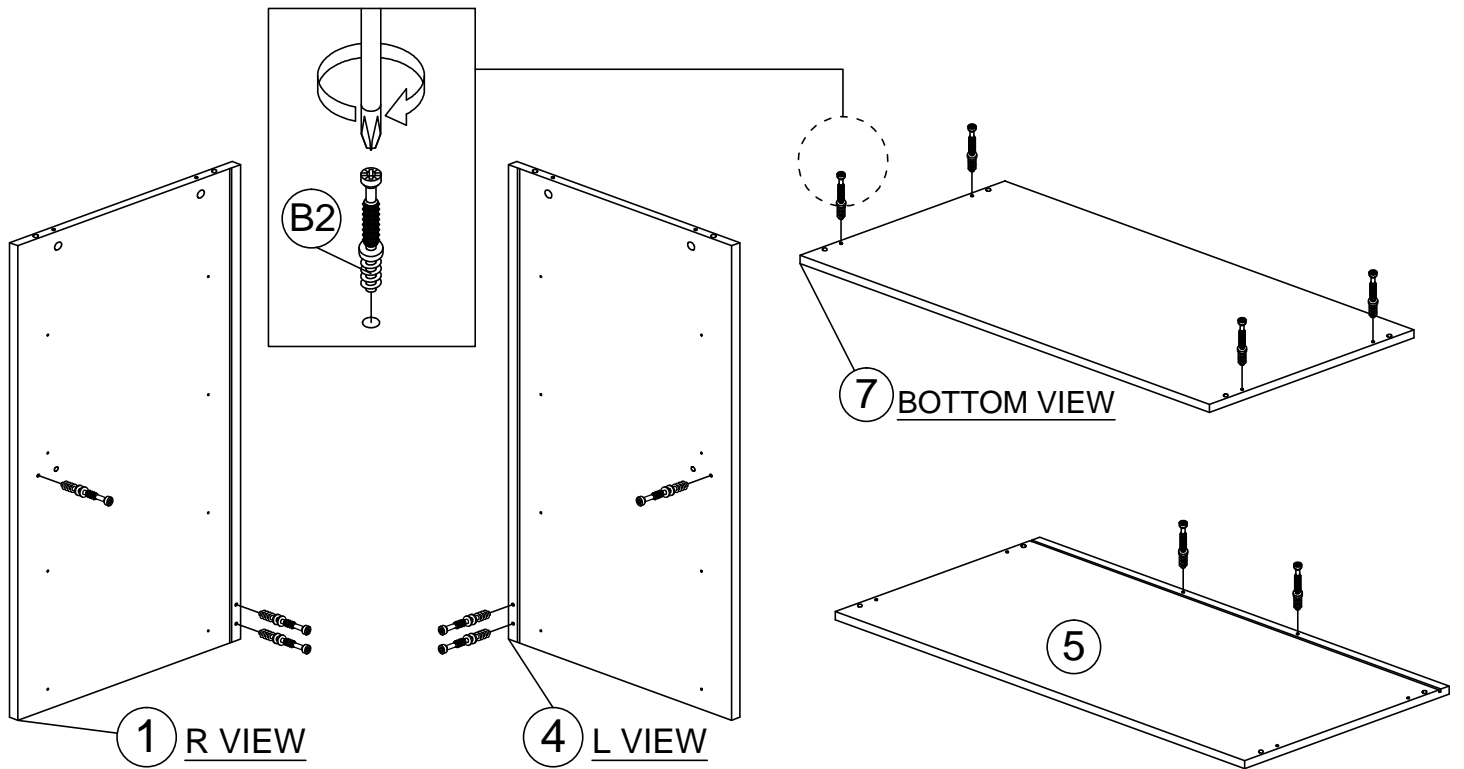

B2	 CAM BOLT	12
----	--	----



THE USE OF POWER TOOLS TO ASSEMBLE THIS PRODUCT WILL INVALIDATE ANY CLAIM AND MAY DAMAGE THIS PRODUCT MAKING IT UNSAFE.



STEP 3

C		CB SCREW M3.5 x 16MM	24
L1		DRAWER SLIDE 14"	8

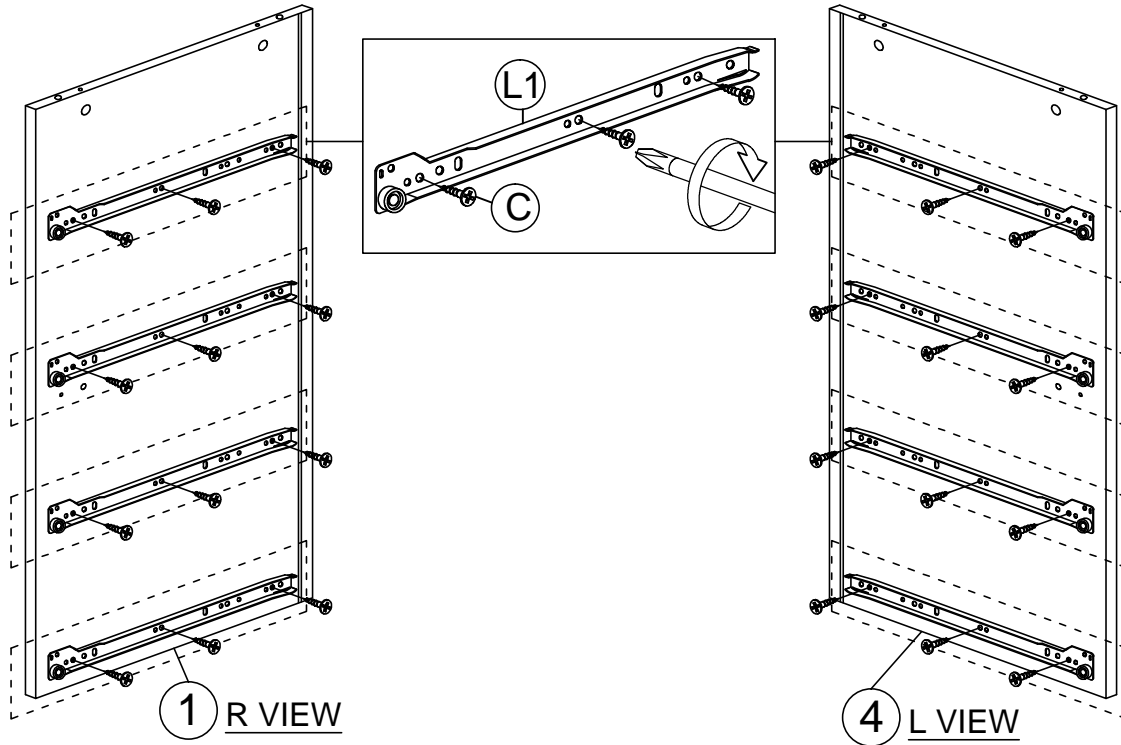

STEP 4

D		CB SCREW M4x38MM	32
---	---	------------------	----

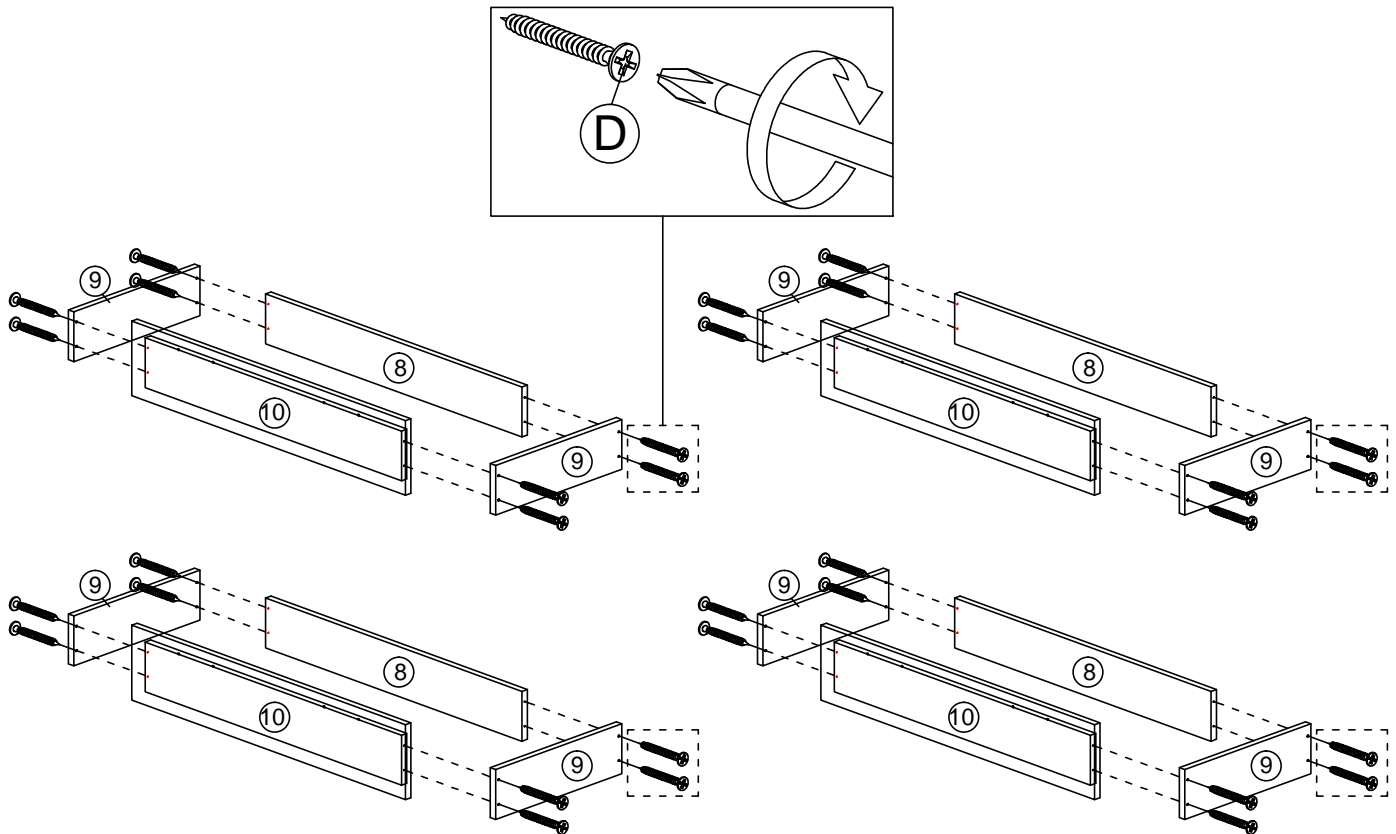

THE USE OF POWER TOOLS TO ASSEMBLE THIS PRODUCT WILL INVALIDATE ANY CLAIM AND MAY DAMAGE THIS PRODUCT MAKING IT UNSAFE.



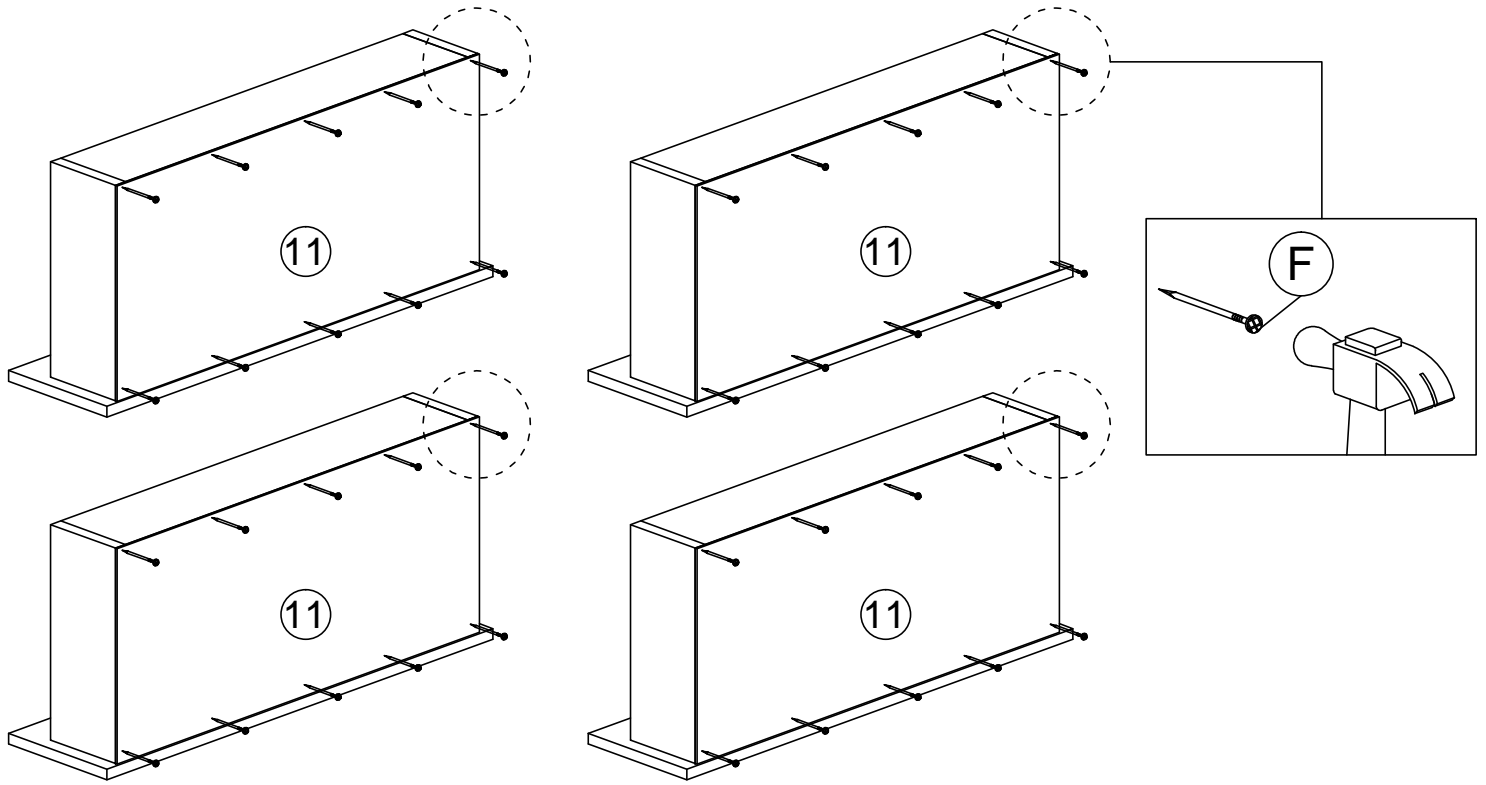

STEP 5

F		NAIL 5/8	40
---	---	----------	----



STEP 6

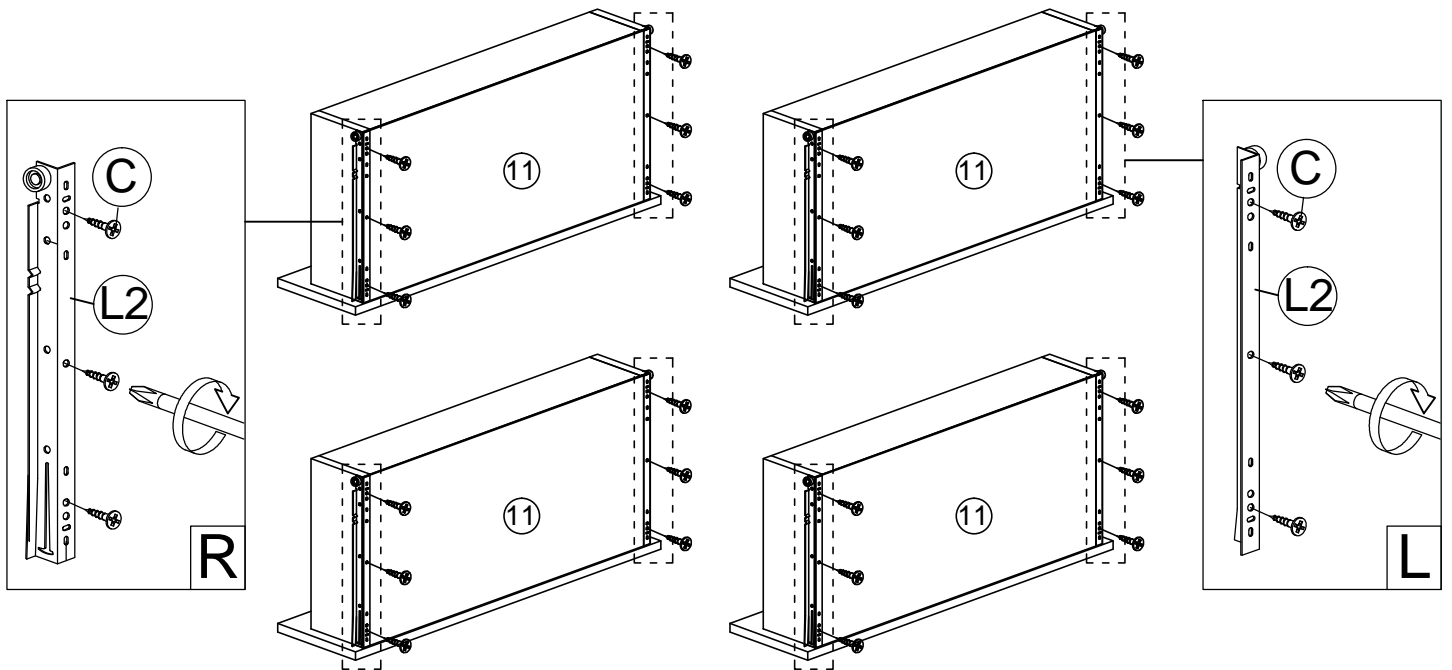

C		CB SCREW M3.5 x 16MM	24
L2		DRAWER SLIDE 14"	8



THE USE OF POWER TOOLS TO ASSEMBLE THIS PRODUCT WILL INVALIDATE ANY CLAIM AND MAY DAMAGE THIS PRODUCT MAKING IT UNSAFE.



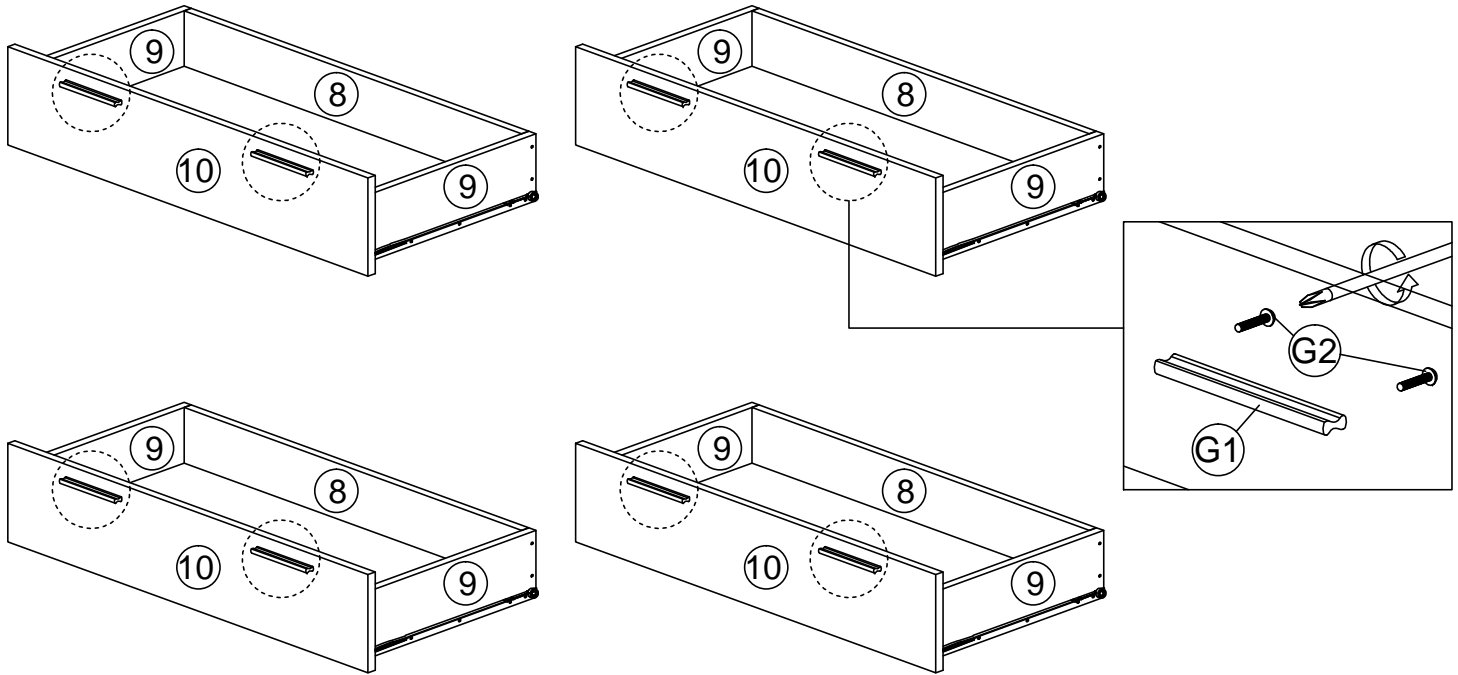

STEP 7

G1		HANDLE 7050-96MM	8
G2		HANDLE SCREW M4 x 19MM	16



STEP 8



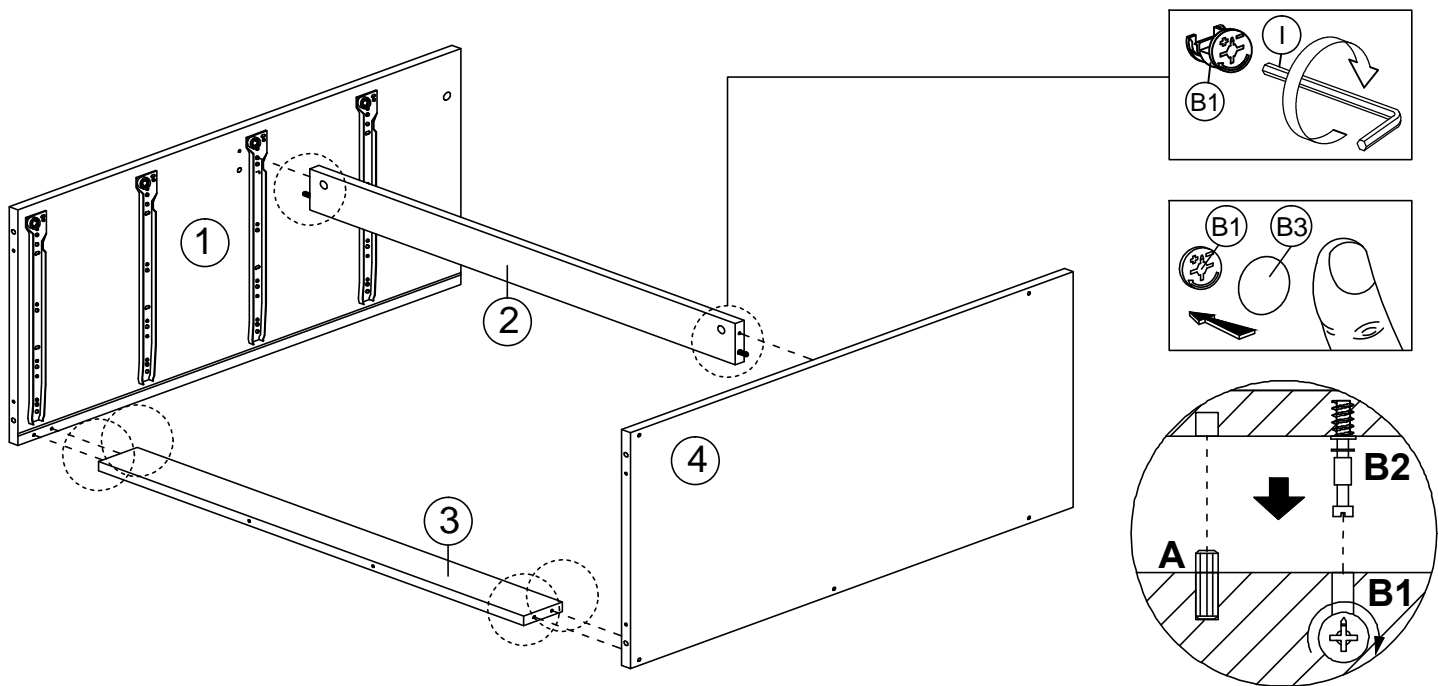

B1		CAM NUT	6
B3		CAM CAP	6
I		ALLEN KEY M4	1



THE USE OF POWER TOOLS TO ASSEMBLE THIS PRODUCT WILL INVALIDATE ANY CLAIM AND MAY DAMAGE THIS PRODUCT MAKING IT UNSAFE.



STEP 9

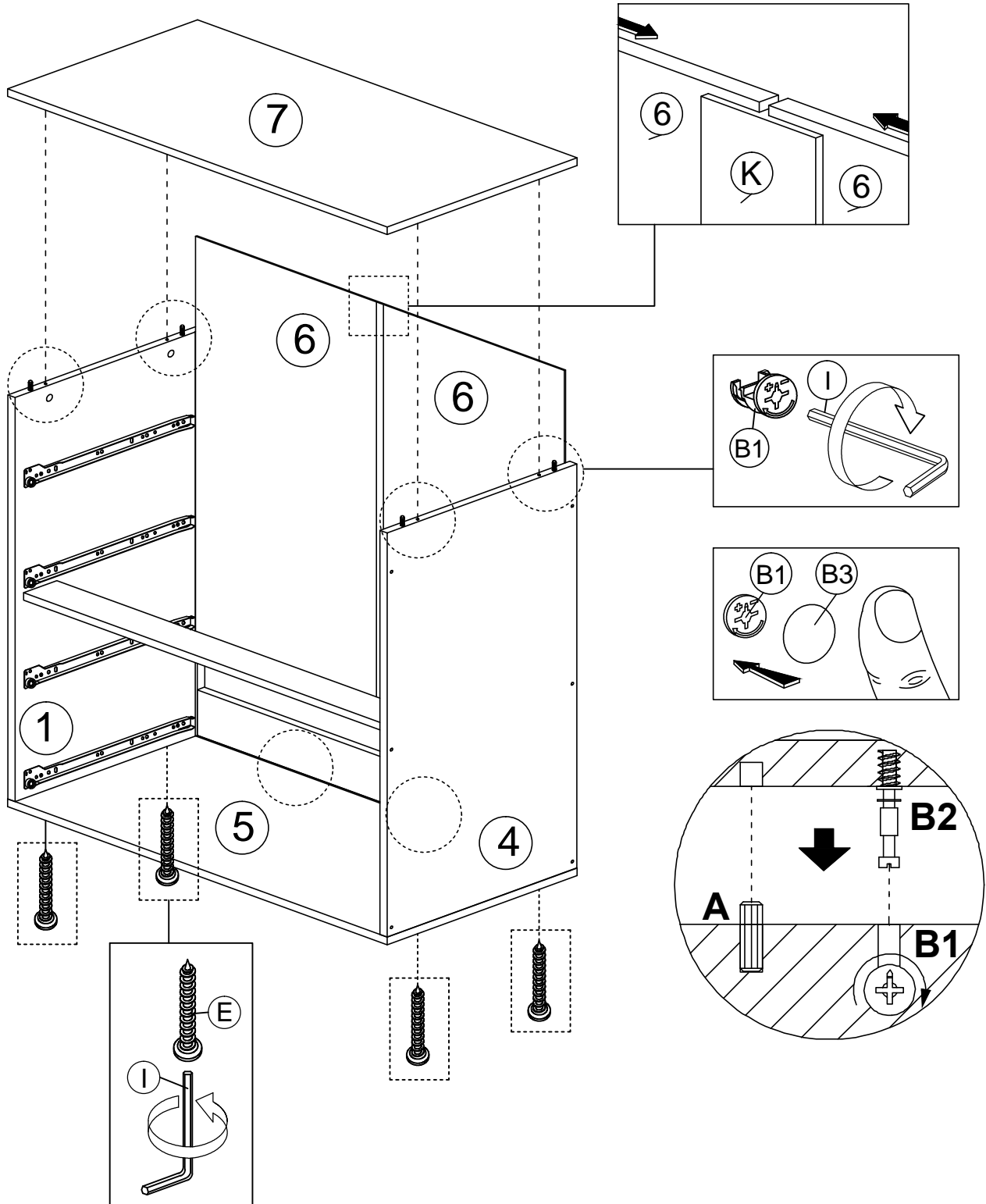

B1		CAM NUT	6
B3		CAM CAP	6
E		CSK CAP WOOD M6 x 50MM	4
I		ALLEN KEY M4	1
K		3MM PVH	1



THE USE OF POWER TOOLS TO ASSEMBLE THIS PRODUCT WILL INVALIDATE ANY CLAIM AND MAY DAMAGE THIS PRODUCT MAKING IT UNSAFE.



STEP 10

C		CB SCREW M3.5 x 16MM	8
J		PVC CORNER L BRACKET	4

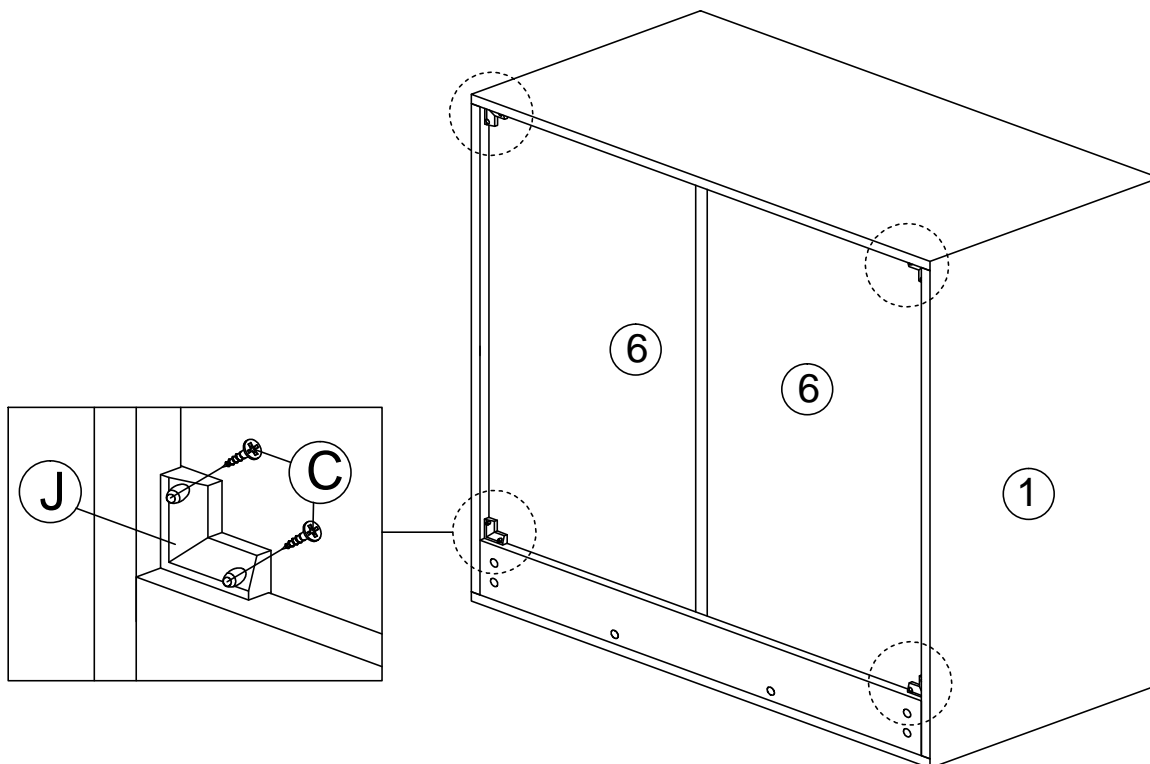

STEP 11

H		HANDLE SCREW M4 x 30MM	12
---	---	------------------------	----

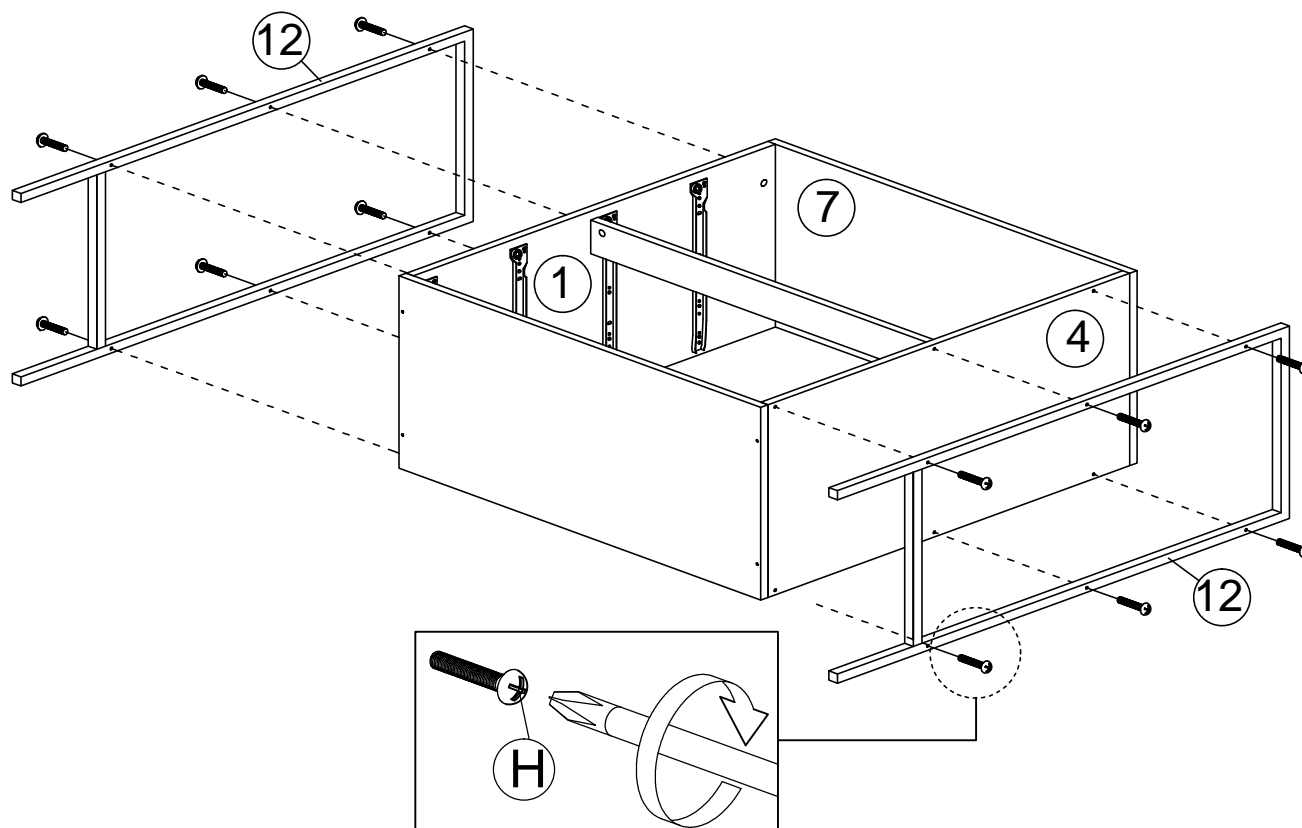

THE USE OF POWER TOOLS TO ASSEMBLE THIS PRODUCT WILL INVALIDATE ANY CLAIM AND MAY DAMAGE THIS PRODUCT MAKING IT UNSAFE.



STEP 12

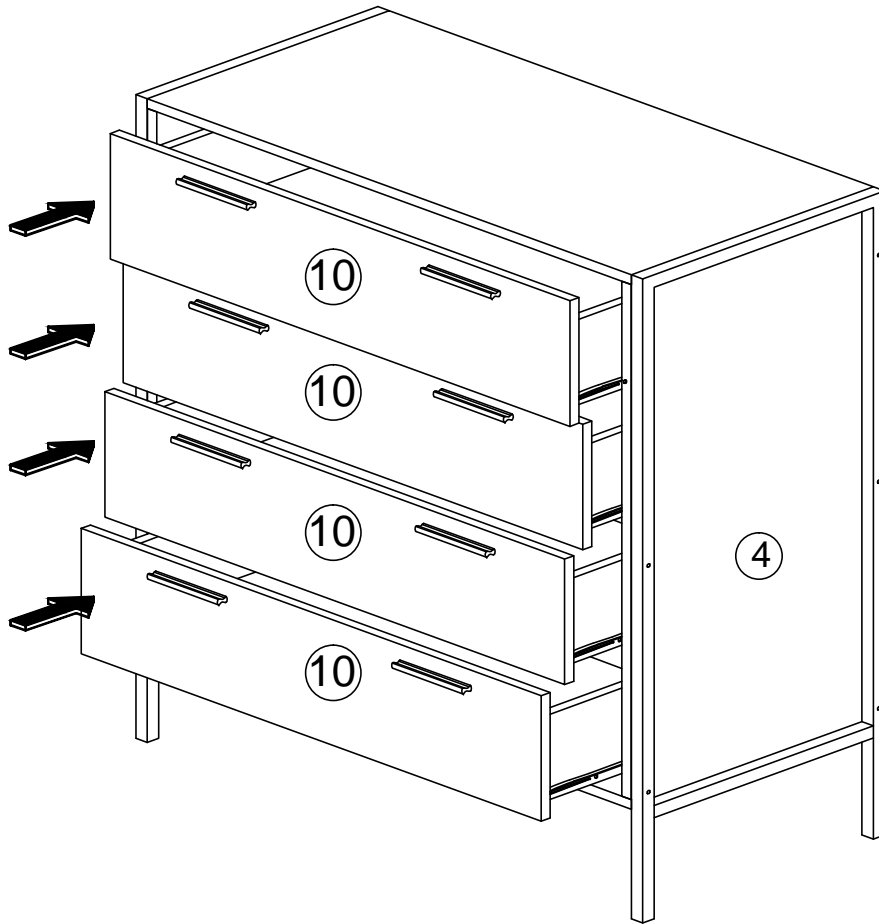

COMPLETED

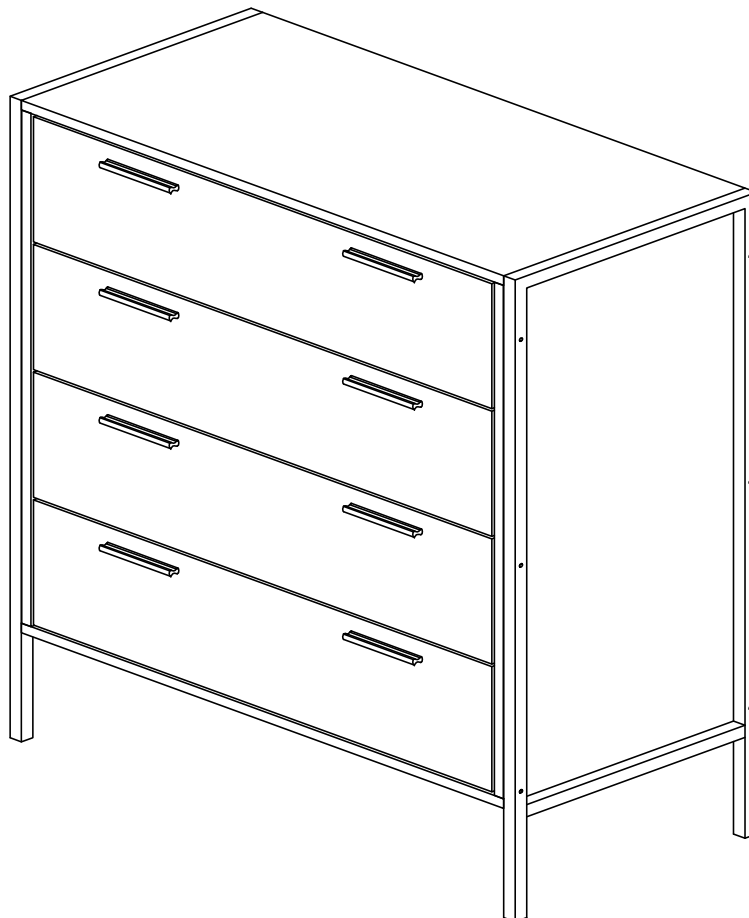

THE USE OF POWER TOOLS TO ASSEMBLE THIS PRODUCT WILL INVALIDATE ANY CLAIM AND MAY DAMAGE THIS PRODUCT MAKING IT UNSAFE.



Installation of Anti-Tip Restraint

Kit includes:

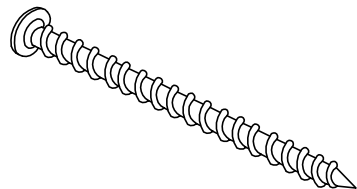

A (x1)
Long screw

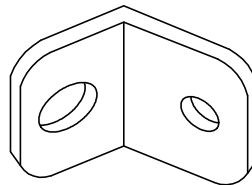

B (x2)
Mounting bracket

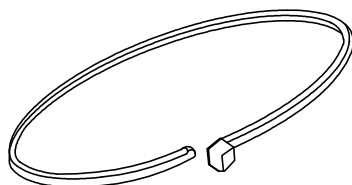

C (x1)
Restraint strap

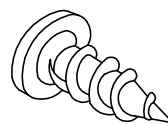

D (x1)
Short screw



WARNING



Serious or fatal crushing injuries can occur from furniture tip-over. To help Prevent tip-over:

- Install tip-over restraint provided
- Place heaviest items in the lower drawers
- Do not set TV's or other heavy objects on top of this product
- Never allow children to climb or hang on drawers, doors or shelves
- Never open more than one drawer at a time
- Do not defeat or remove the drawer interlock system

Use tip-over restraints may only reduce but not eliminate the risk of tip-over.

FITTING OF ANTI-TIP SAFETY STRAP

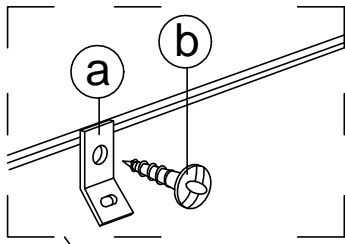

STEP 1:

- Attach the mounting bracket (a) to the furniture in the solid part below the top panel a few inches away from the side of the unit.
- Screw (b) through the smallest hole of (a).

BACK SIDE OF TOP PANEL

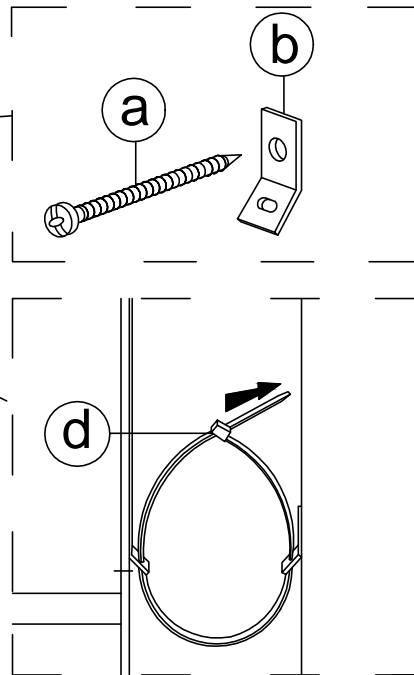

STEP 2:

- Locate a stud in behind the have to
- Place the other mounting bracket (a) on the wall stud 2 inches below the mounting bracket secured to the back of your unit.
- Attach to the wall stud using (c) through the smaller hole of (a).

← WALL

FURNITURE

STEP 3:

- Repeat the same step a few inches away from the other side of the unit.
- Place the furniture into position so both mounting brackets are vertically in line.
- Lace the end of the restraint strap through the larger holes in each mounting bracket.
- Secure the straps and lock into place.

