

Model :
(4'6" Full & 5' Queen)

Assembly Instruction

Step 1: Fix the headboard and footboard with legs as shown.

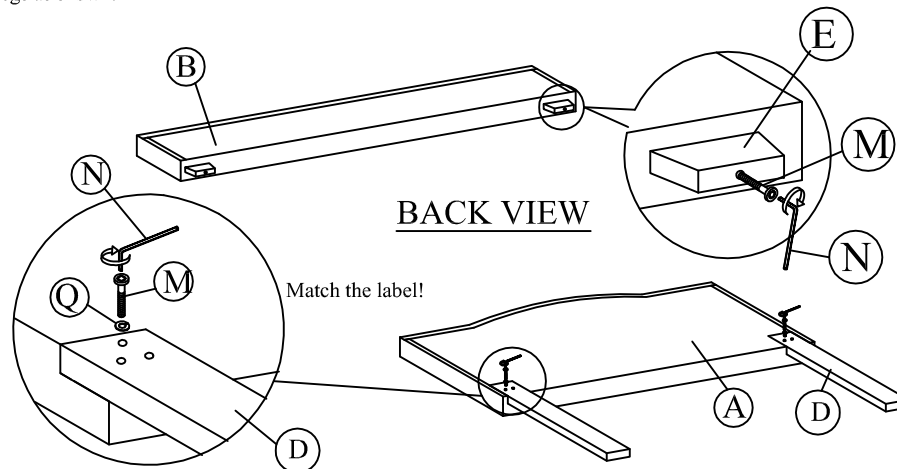

Step 2: Attach the JCBB Bolt (J) to the headboard bracket and footboard bracket .

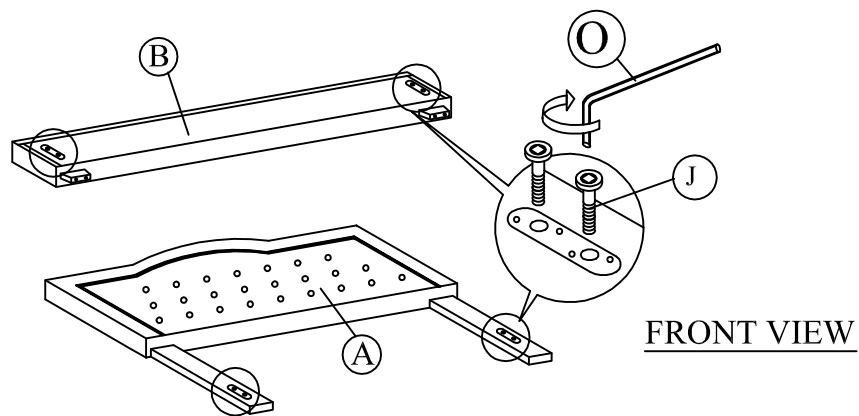

Step 3: Attach the side rail support wood (G) to the side rail (C) .

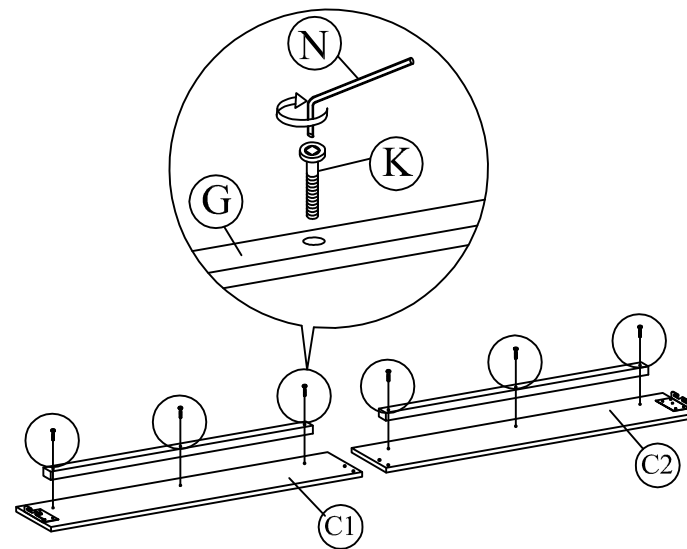

A		Headboard	1pc
B		Footboard	1pc
C		Side Rail	4pcs
D		Headboard Legs	2pcs
E		Footboard Legs	2pcs
F		Side Rail Legs	2pcs
G		Side Rail Support Wood	4pcs
H		Slat	4pcs
I		Support Legs	4pcs
J		JCBB M8 x16	8pcs
K		JCBC M6 x 30	12 pcs
L		JCBC M6 x 35	12 pcs
M		JCBC M6 x 50	8 pcs
N		Allen Key 100mm	1pc
O		Allen Key 70mm	1pc
P		CSK Screw 32mm	8pcs
Q		Spring Washers	6pcs
R		Flat Washers	8pcs

Step 4: Attach the side rail leg (F) to the side rail (C).

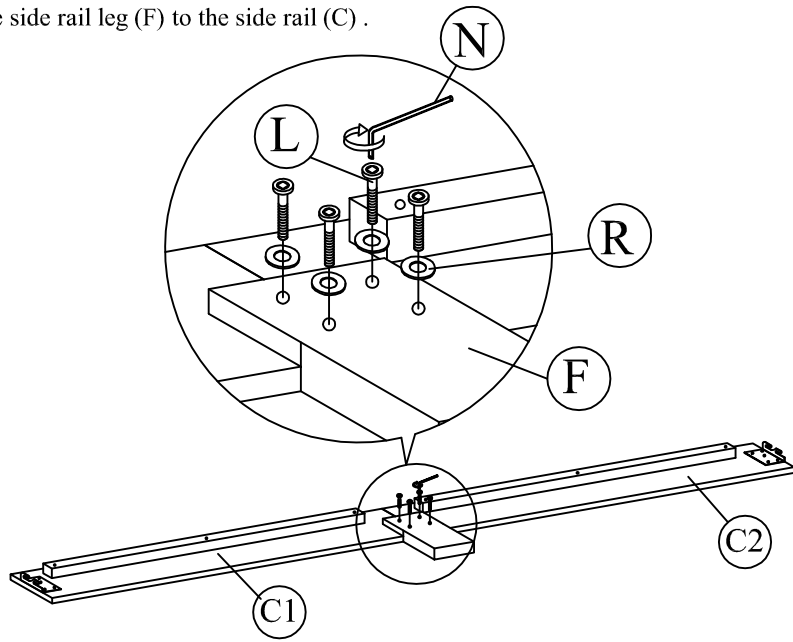

Step 5: Attach side rail (C) to headboard (A) and footboard (B) by pushing the bracket down to fit it.

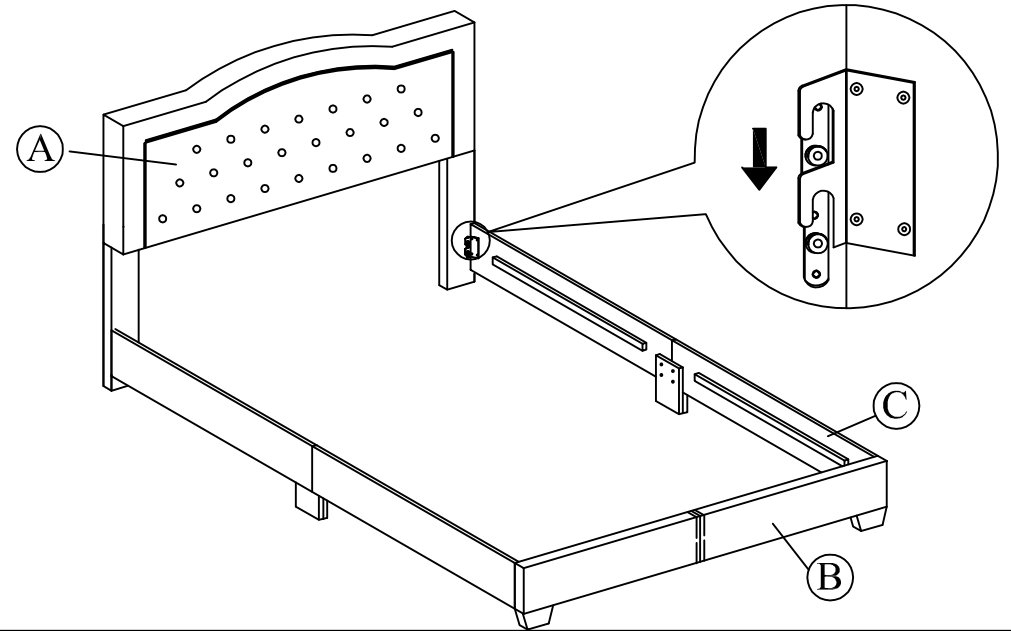

Step 6: Attach the support legs (I) to the slats (H).

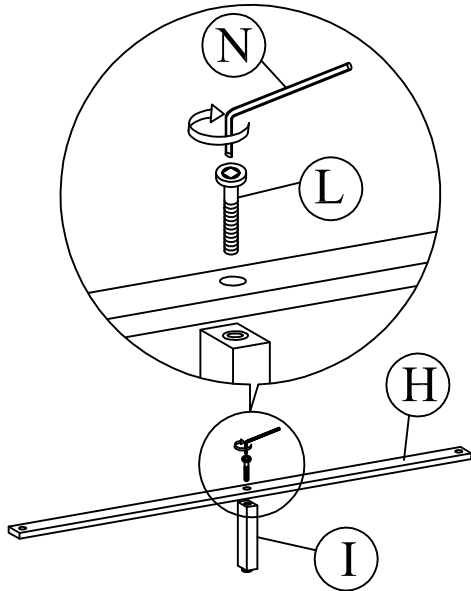

Step 7: Tighten the 4 Corner with Allen Key (O). Install the bed slats to side rail. Tighten the slats with CSK screw. The distance of the slats should be sufficient to obtain desirable bed stability.

