

Installation & Assembly

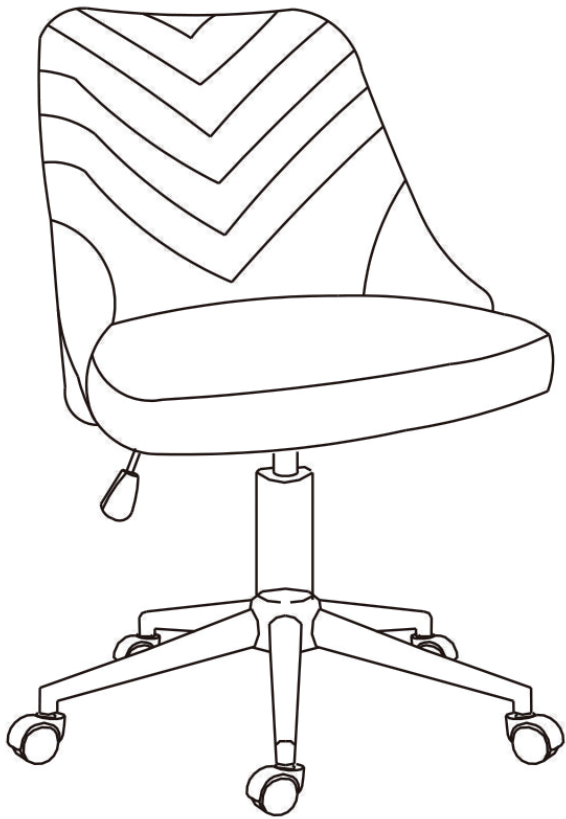

Chair



y Guide

Do check for all the components and screws guide before putting things together. If any part is missing, contact us.

Your satisfaction is our top priority. If our **Assembl** tisify you, please let us know make things right for you. Our care team can handle most concerns and assist you with any questions listed in this o be eligible for a full-refund must be in pristine condition, packaging, with all of the ts intact and not yet with the item's unique proof

Return Policy

product fails to sa
how we can
trained customer

you
retu
in th
ship
ass
of p



Item Description: Chair

Trouble shooting:

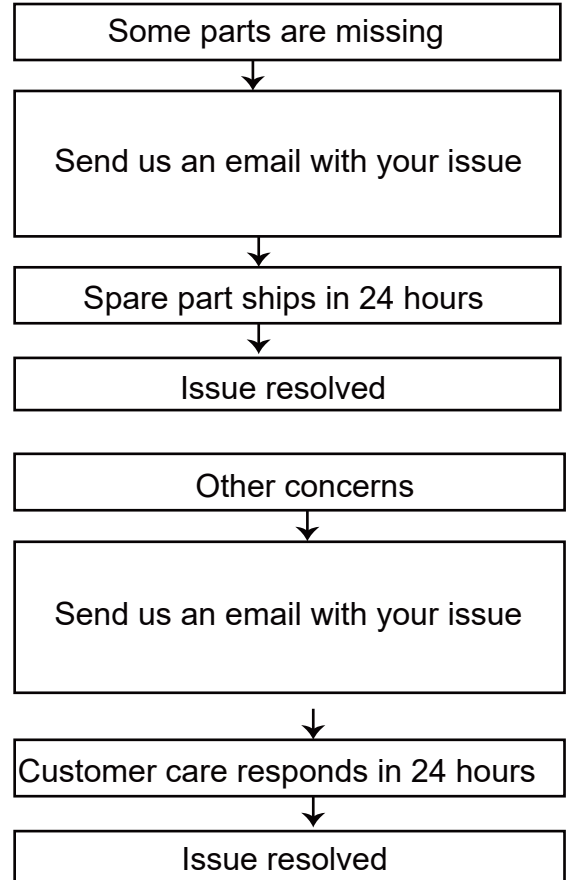

We run our own manufacturer, so rest assured about the quality consistency.

Guide de montage

Attention !

VÉRIFIEZ la présence de l'ensemble des éléments et vis énumérés dans ce guide avant de procéder au montage.

Politique de retour

Votre satisfaction est notre priorité absolue. Si notre produit ne vous donne pas entière satisfaction, n'hésitez pas à nous faire savoir ce que nous pouvons faire pour améliorer la situation. Notre équipe d'assistance à la clientèle qualifiée est en mesure de résoudre la plupart de vos problèmes et de répondre à toutes vos questions. Pour pouvoir bénéficier d'un remboursement intégral, l'article doit être en parfait état, dans son emballage d'origine, avec tous les composants expédiés intacts et non encore assemblés, et avec la preuve d'achat unique de l'article.

Dépannage :

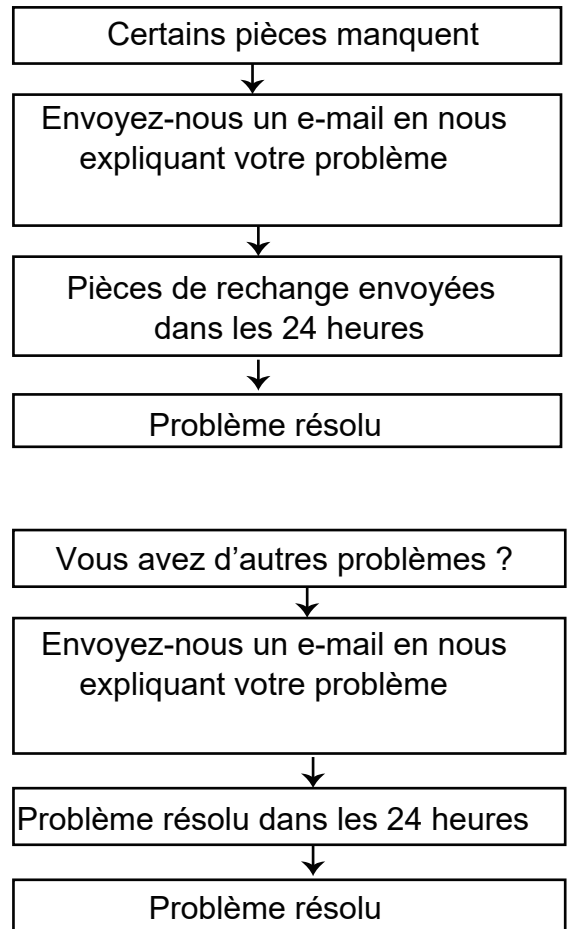

Nous assurons notre propre fabrication, donc soyez assuré de bénéficier d'une qualité constante.



Item Description: Chaise

Guida all'assemblaggio

Mancia!

Controllare tutti i componenti e le viti elencati in questa guida prima di inserire le cose insieme. Se manca qualche parte,

Politica di ritorno

La vostra soddisfazione è la nostra massima priorità. Se il nostro il prodotto non ti soddisfa, faccelo sapere come possiamo sistemare le cose per te. Nostro un team di assistenza clienti qualificato può gestire la maggior parte preoccupazioni e assistervi per qualsiasi domanda tu forse hai. Essere eleggibile per un reso con rimborso completo, l'articolo deve essere presente ottime condizioni, nella confezione originale, con tutti i componenti spediti intatti e non ancora assemblato e con l'oggetto unico prova d'acquisto.

Risoluzione dei problemi:

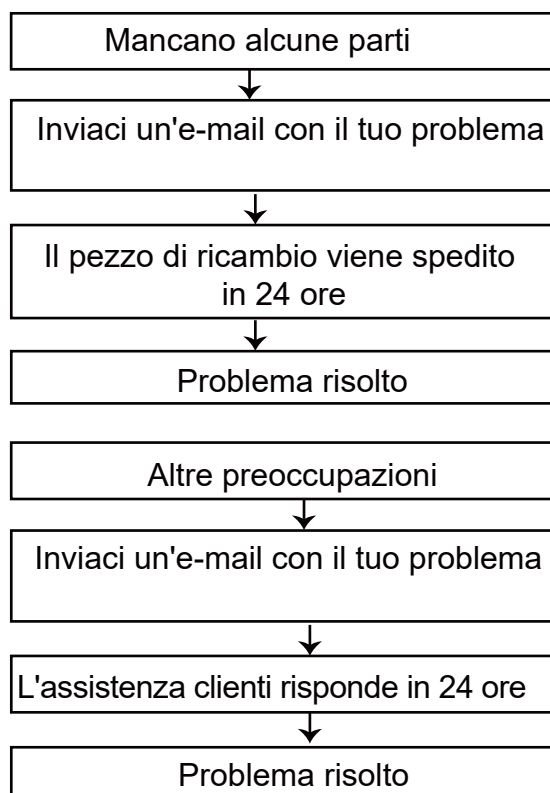





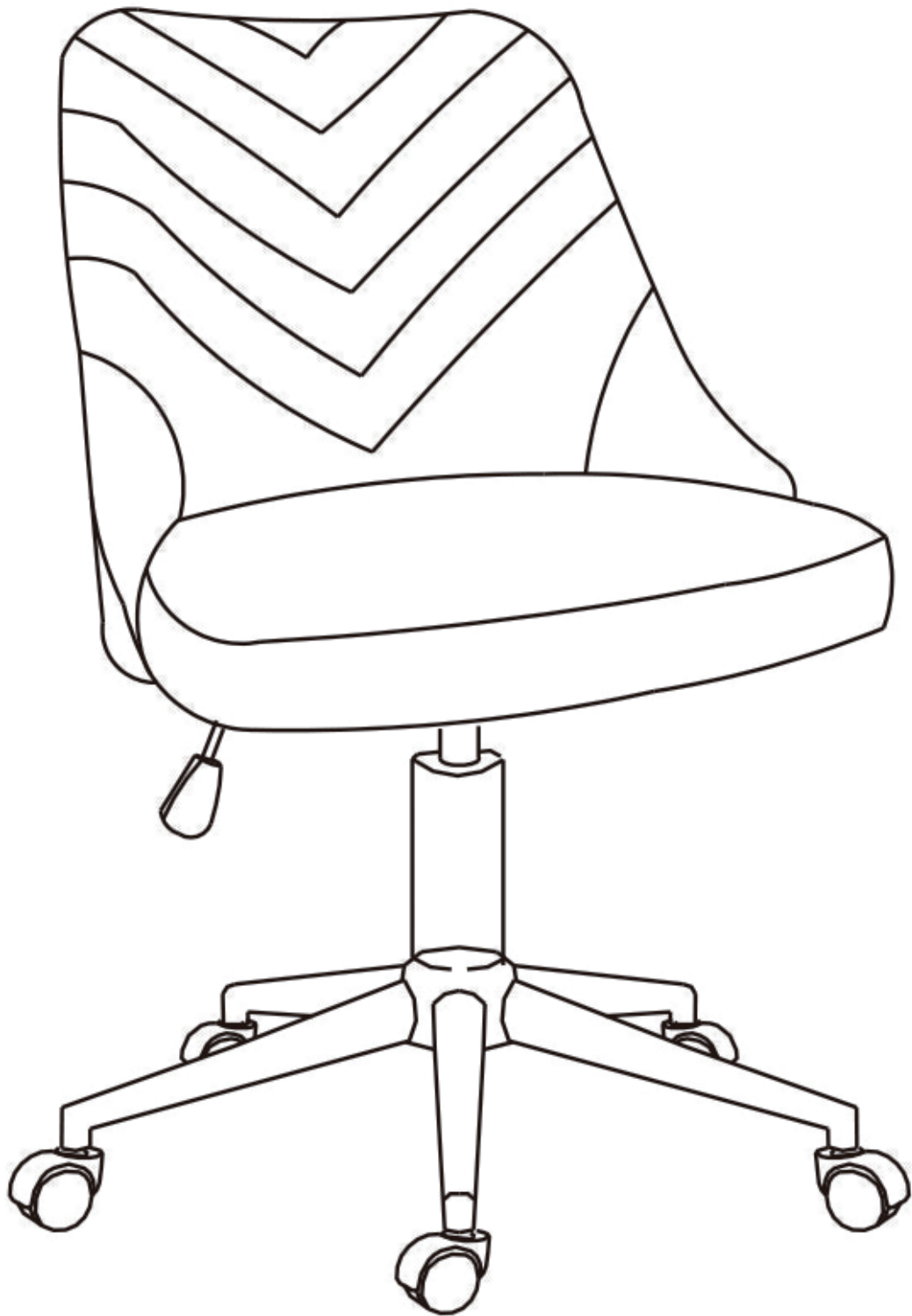

Gestiamo il nostro produttore, quindi riposati assicurato circa la consistenza di qualità.

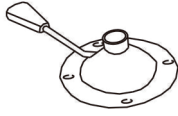

Descrizione dell'articolo: Sedia

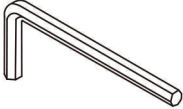

<p>A</p>	 <p>50mm castors</p>	<p>5pcs</p>	<p>E</p>	 <p>16.5*16.5*5.5cm Mechanism</p>	<p>1pc</p>
<p>B</p>	 <p>320mm Feet</p>	<p>1pc</p>	<p>F</p>	 <p>50*54*42.5cm Seat</p>	<p>1pc</p>
<p>C</p>	 <p>120mm Gas Spring</p>	<p>1pc</p>	<p>G</p>	 <p>M6 20mm screws</p>	<p>4pcs</p>
<p>D</p>	 <p>D85 Decoration Ring</p>	<p>1pc</p>	<p>H</p>	 <p>Allen Key</p>	<p>1pc</p>

Step 1

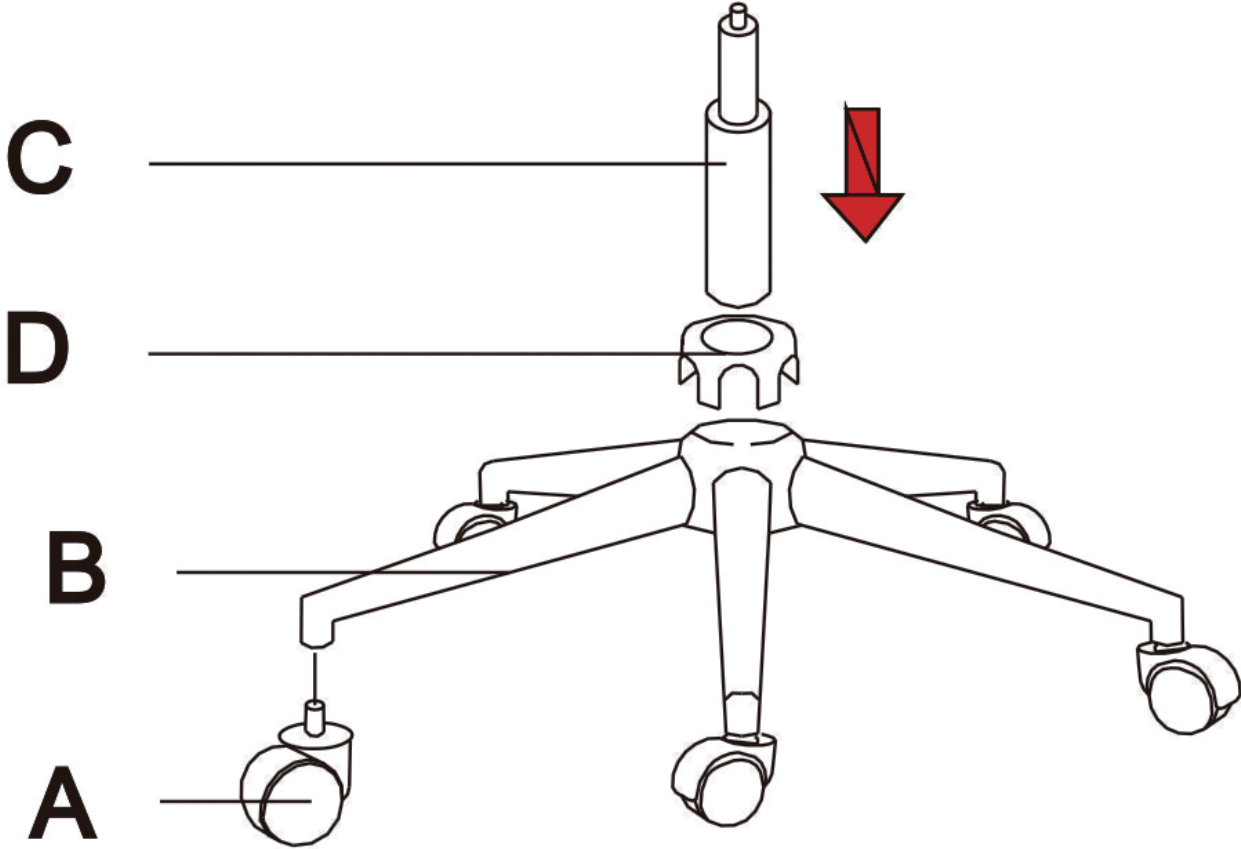

Step 2

Gx4

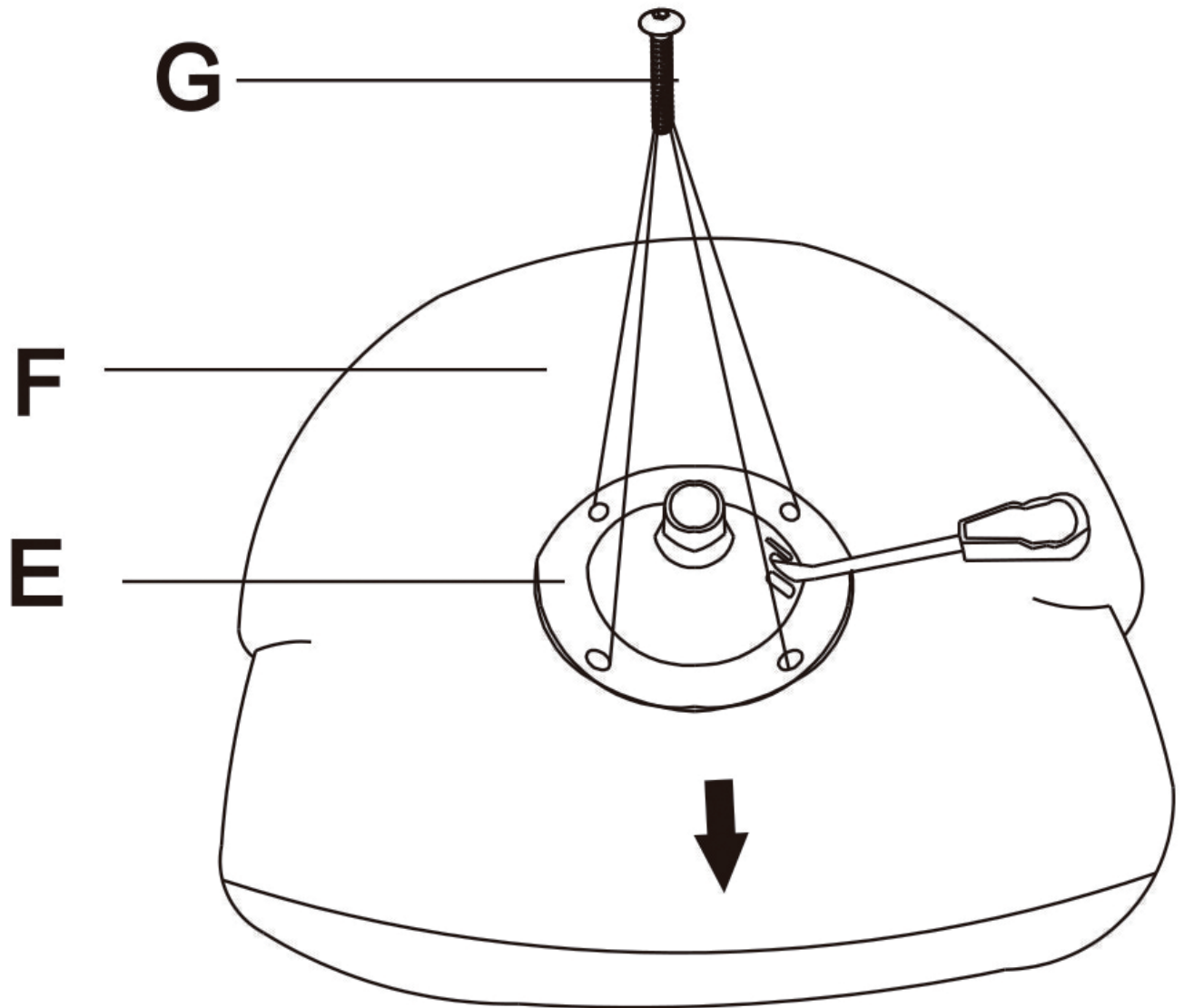

Step 3

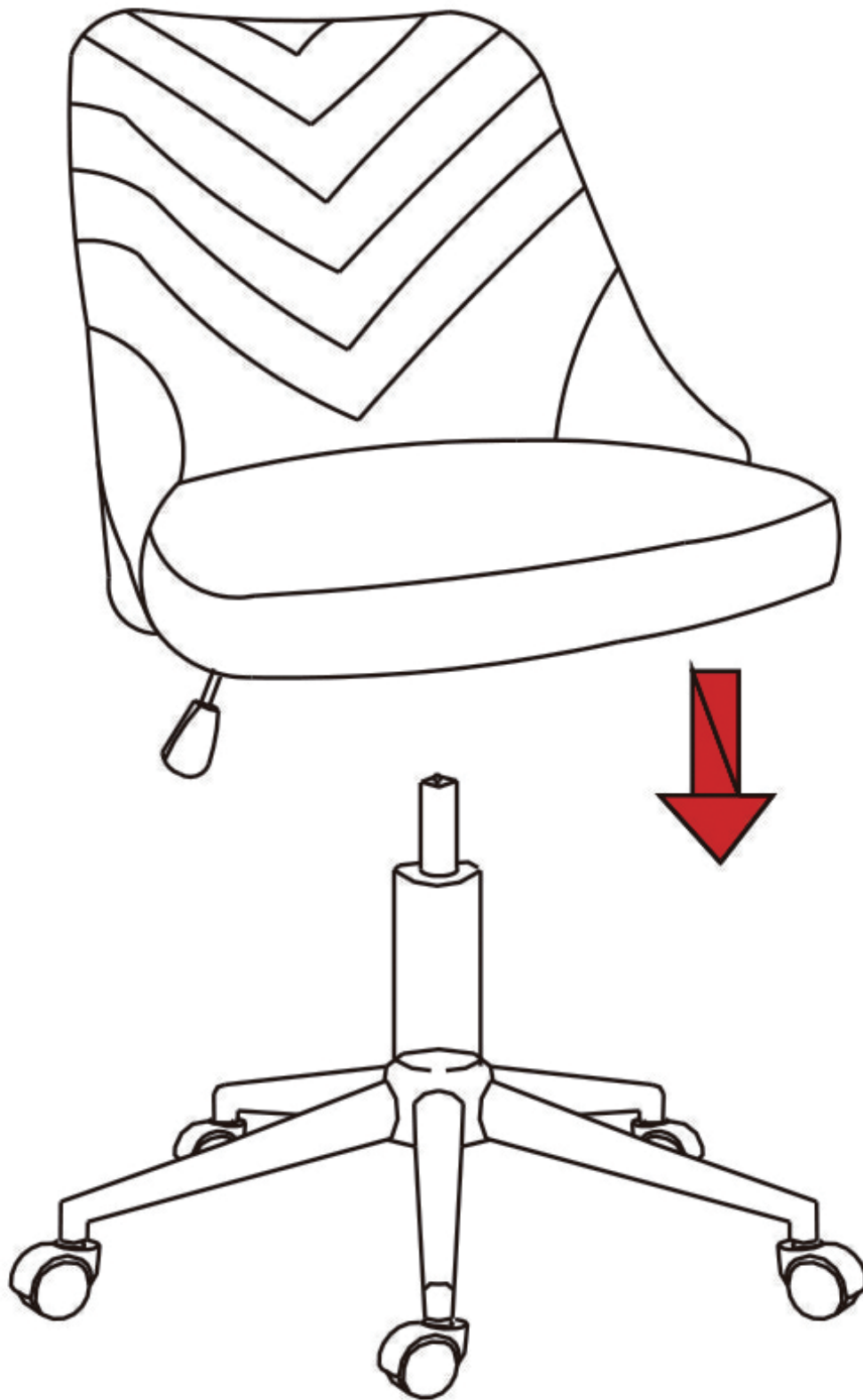

Step 4

