

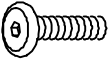



---

## HARDWARE LIST

 <b>HA X 18</b> (1/4" X 1-3/4")	 <b>HB X 6</b> (1/4" X 1")	 <b>HC X 6</b> (1/4" X 2-3/8")
 <b>HD X 26</b> (1/4" )	 <b>HE X 26</b> (1/4" )	 <b>HF X 1</b> <b>Allen Wrench</b>

\*\*\* **Note:** Find the label of "Hardware Enclosed" on one of the carton corner then follow the red ribbon to get the hardware bag.

\*\*\* **Remarque:** Repérez l'étiquette «Quincaillerie Incluse» sur le coin de la boîte, puis suivez le ruban rouge pour récupérer le sac contenant la quincaillerie.

\*\*\* **Nota:** Busque la etiqueta "Ferretería Incluida" en una de las esquinas de la caja, luego siga la cinta roja para recuperar la bolsa que contiene la tornillería.

---

## **PARTS LIST**

### **SPARE PARTS - available for replacement**

<b>DESCRIPTION</b>	<b>QTY</b>
<b>OVAL BACK</b>	<b>01</b>
<b>LEFT SIDE ARMREST</b>	<b>01</b>
<b>RIGHT SIDE ARMREST</b>	<b>01</b>
<b>MIDDLE RING</b>	<b>01</b>
<b>FOOTREST RING</b>	<b>01</b>
<b>LEGS</b>	<b>04</b>
<b>HARDWARE PACK</b>	<b>01</b>

### **SPARE PARTS - not available for replacement**

<b>DESCRIPTION</b>	<b>QTY</b>
<b>CUSHION SEAT</b>	<b>01</b>

---

### IMPORTANT:

1. Do not tighten bolts completely until all bolts are completely lined up and inserted into holes / nuts.
2. Do not over tighten screws and bolts to avoid stripping.
3. Please use hand tools to assemble this product. Do not use power tools.
4. For ease of assembly, two adults are recommended.

### IMPORTANT:

1. Ne serrez pas complètement les boulons jusqu'à ce que tous les boulons soient complètement alignés et insérés dans les trous / écrous.
2. Ne pas trop serrer les vis et les boulons pour éviter d'endommager les filets.
3. Utilisez des outils à main pour assembler ce produit. N'utilisez pas d'outils électriques.
4. L'assemblage par deux adultes est recommandé.



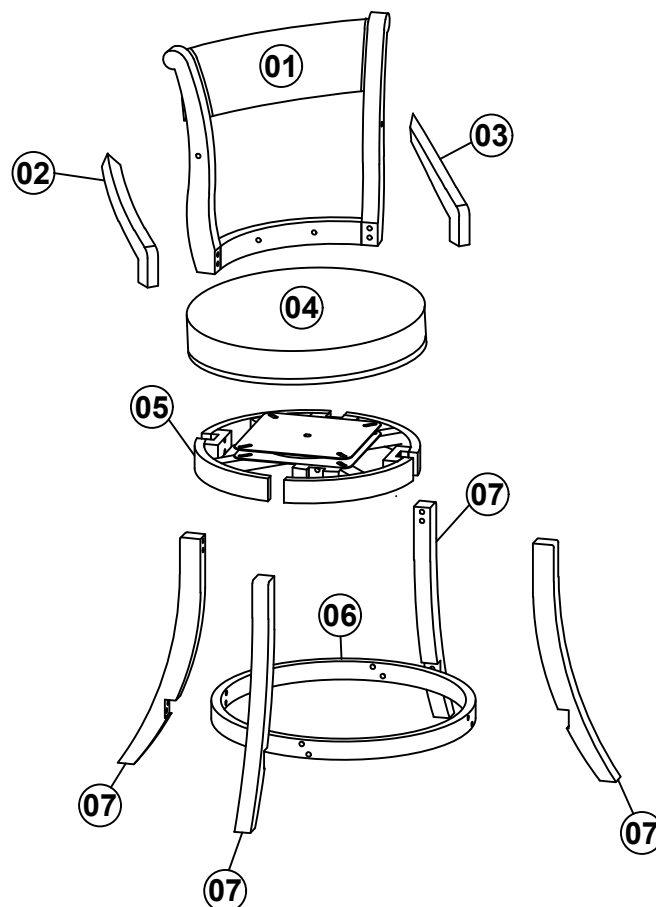

### IMPORTANTE:

1. No apriete completamente los pernos hasta que todos los tornillos estén alineados completamente y se inserten en los agujeros / tuercas.
2. No apriete demasiado los tornillos y los pernos para evitar dañar los filetes.
3. Utilice herramientas de mano para montar este producto. No utilice herramientas eléctricas.
4. Se recomienda el montaje por dos adultos.

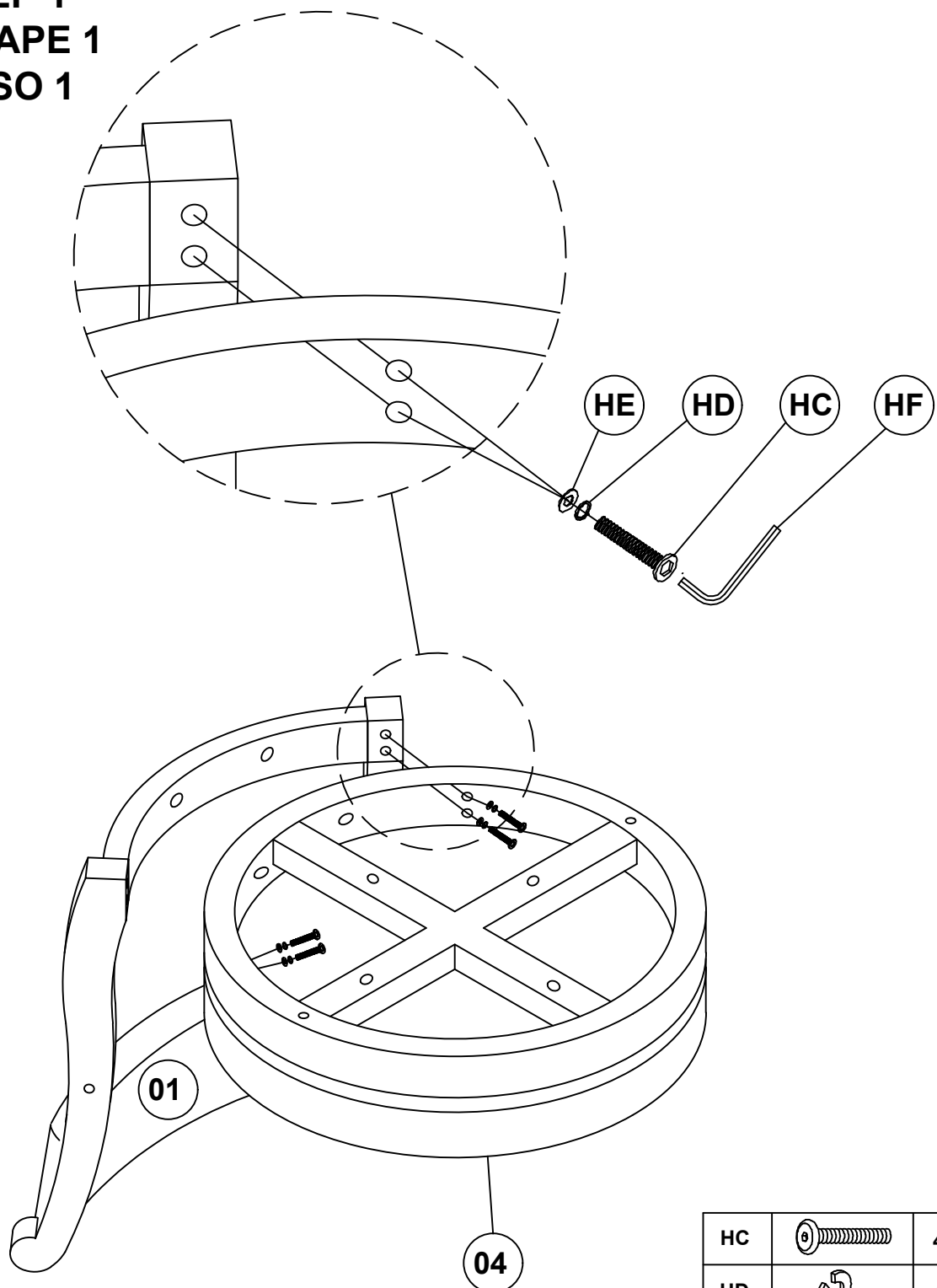





**STEP 1**  
**E'TAPE 1**  
**PASO 1**

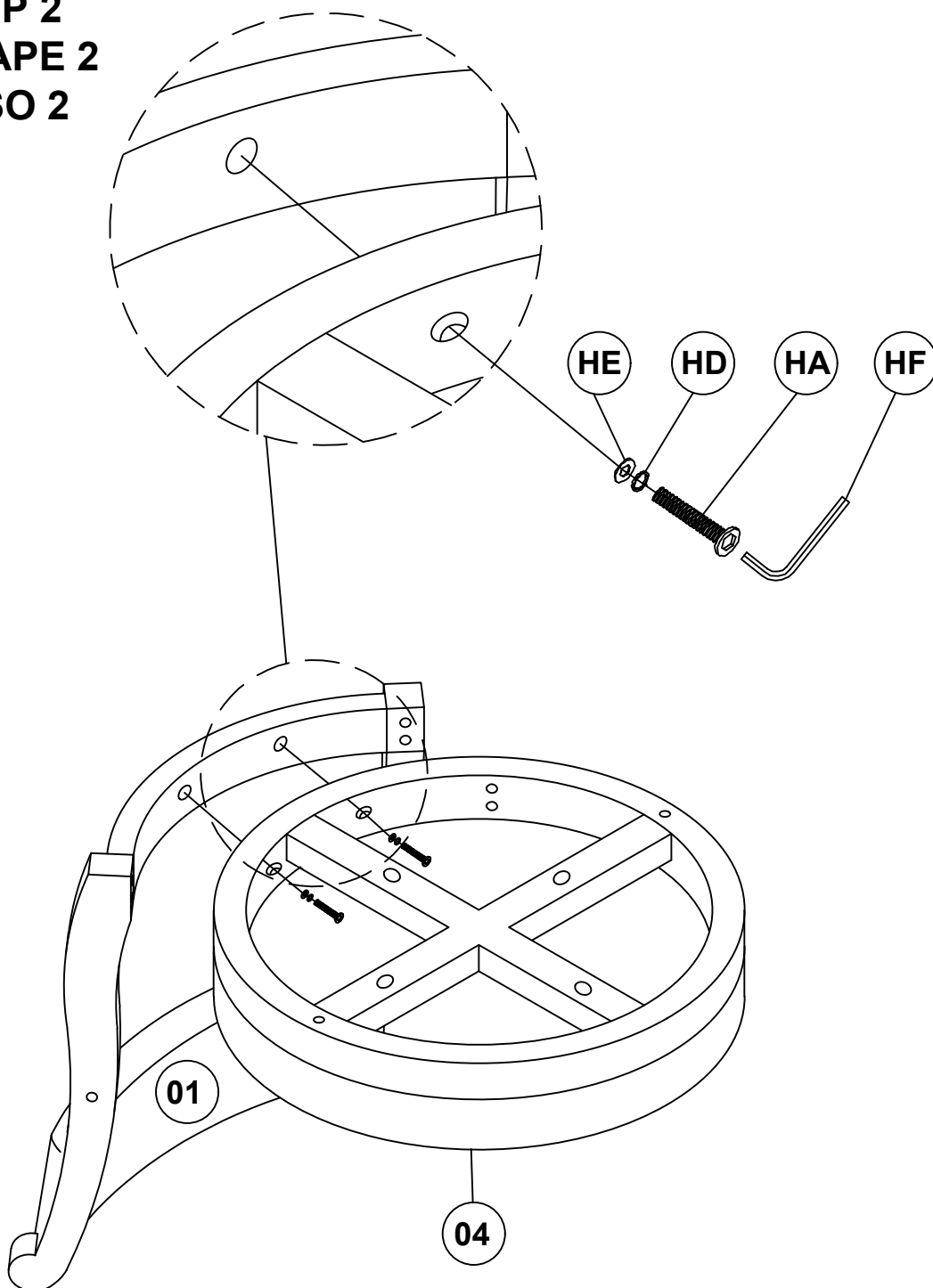

HC		4
HD		4
HE		4
HF		1

**STEP 2**  
**E'TAPE 2**  
**PASO 2**



HA		2
HD		2
HE		2
HF		1

**STEP 3**  
**E'TAPE 3**  
**PASO 3**

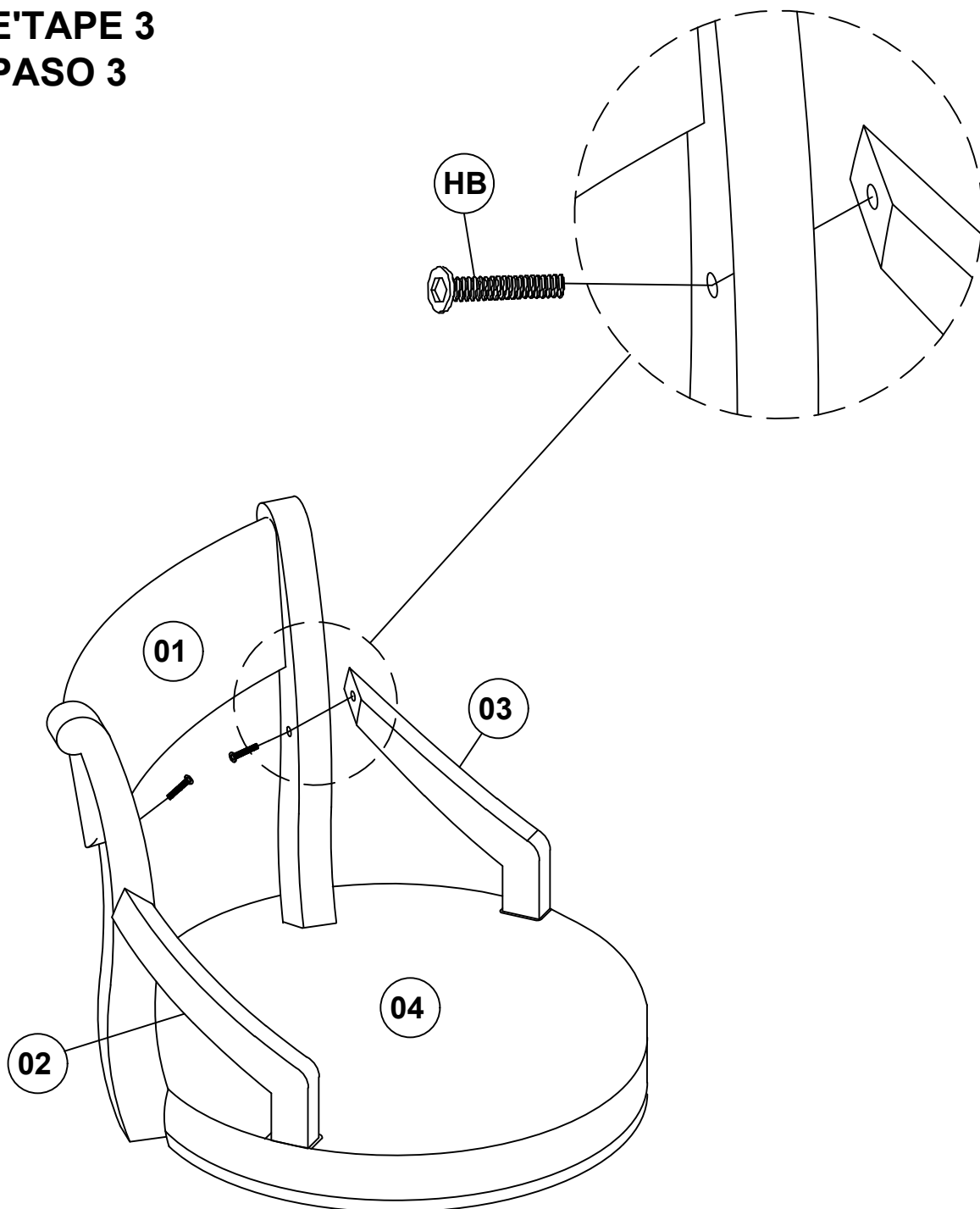

HB		2
----	---------------------------------------------------------------------------------------	---



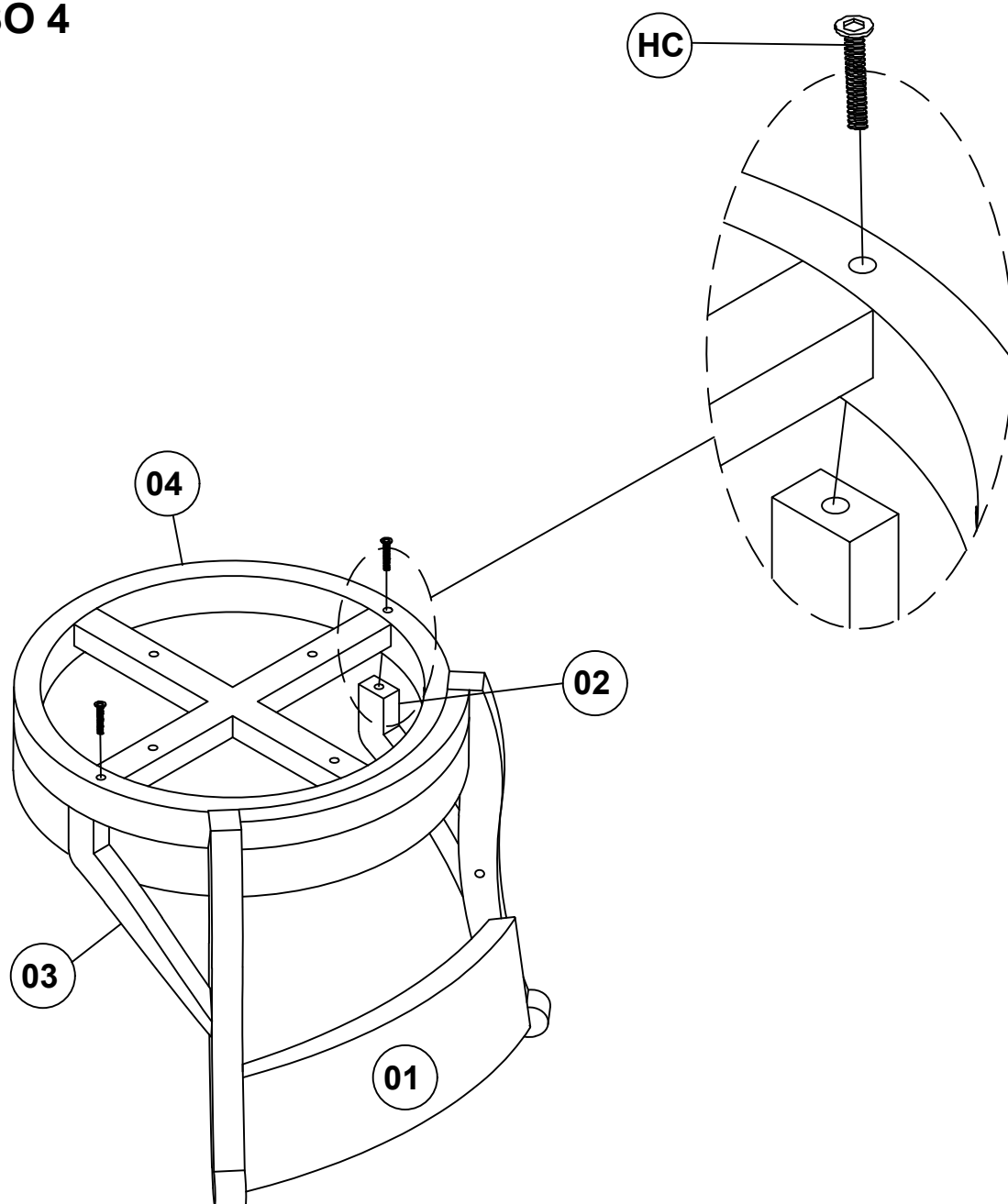

**STEP 4**  
**E'TAPE 4**  
**PASO 4**

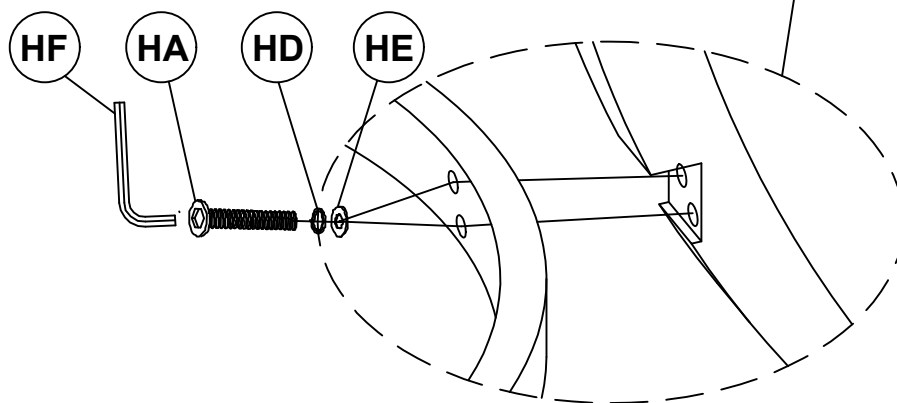
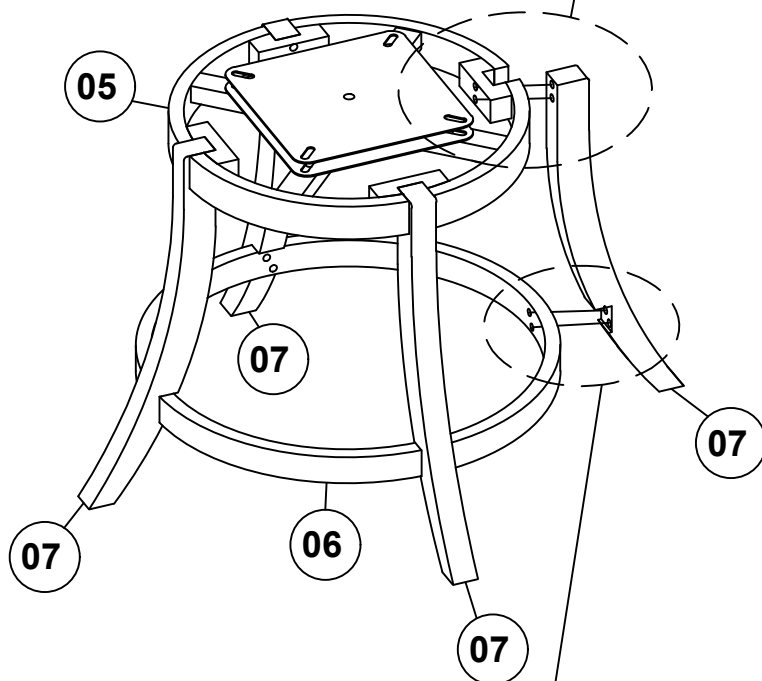
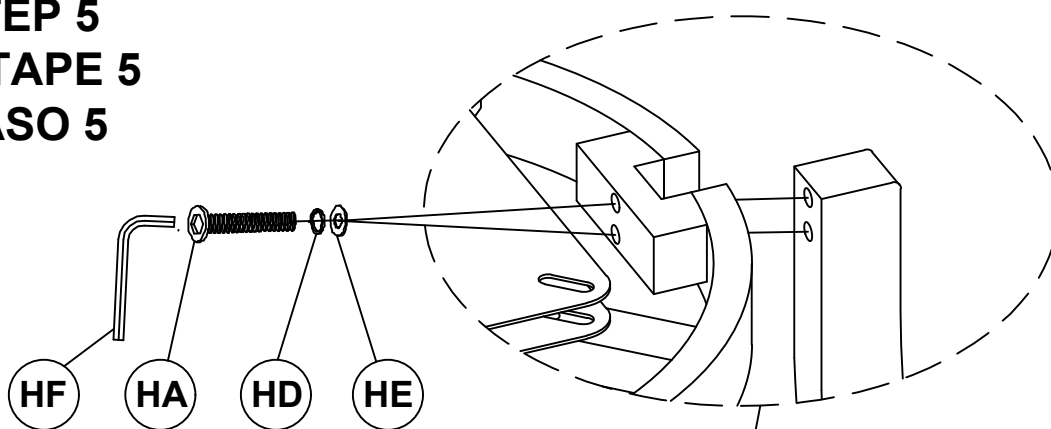

HC		2
----	---------------------------------------------------------------------------------------	---





**STEP 5**  
**E'TAPE 5**  
**PASO 5**

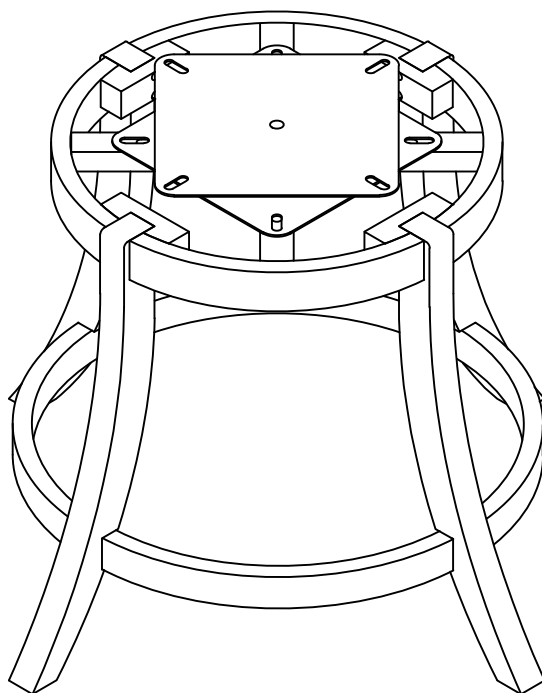
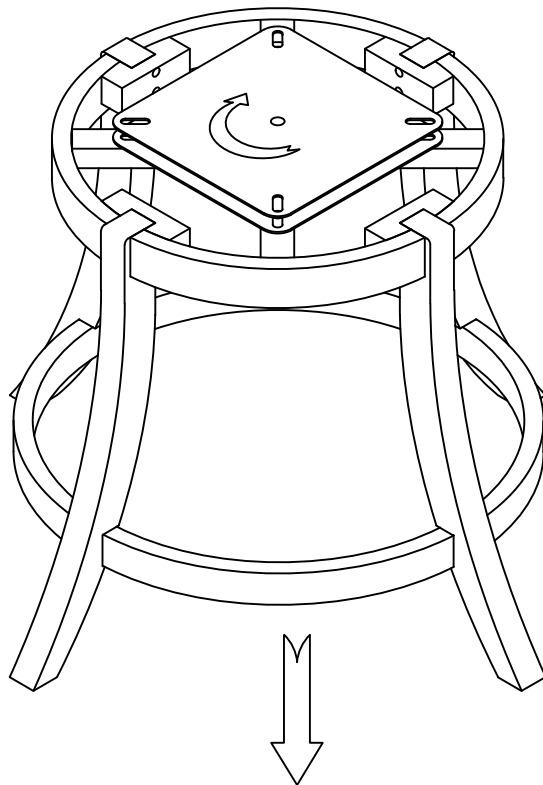

HA		16
HD		16
HE		16
HF		1





**STEP 6**  
**E'TAPE 6**  
**PASO 6**

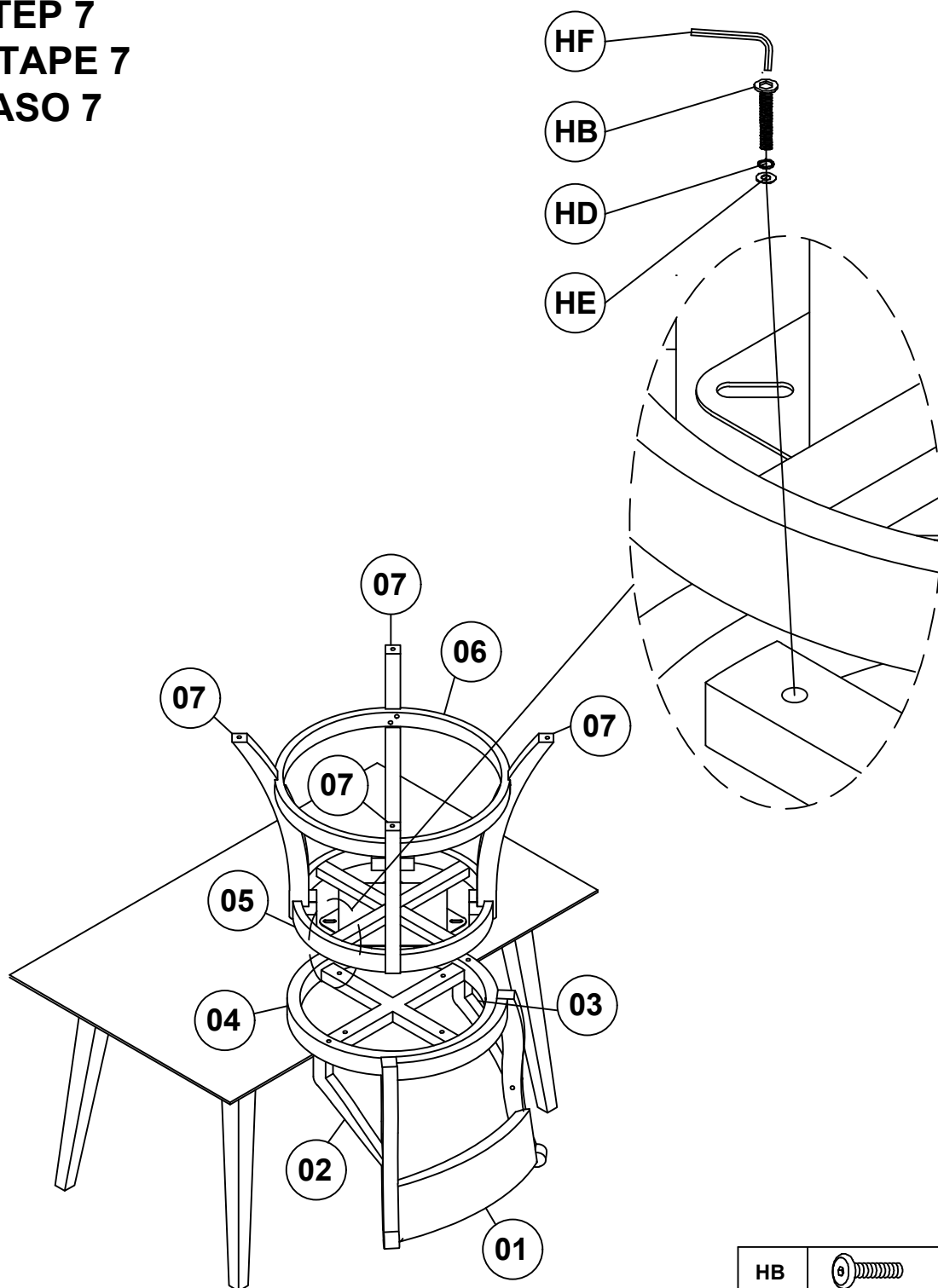

HB		4
HE		4
HF		4
HG		1

**STEP 7**  
**E'TAPE 7**  
**PASO 7**



HB		4
HD		4
HE		4
HF		1

---

**COMPLETED ASSEMBLY  
ASSEMBLAGE TERMINÉ  
ENSAMBLAJE COMPLETADO**

**Maximum Weight 275 lbs  
Poids maximum: 275 lbs (125 kg)  
Peso máximo: 275 lbs (125 kg)**

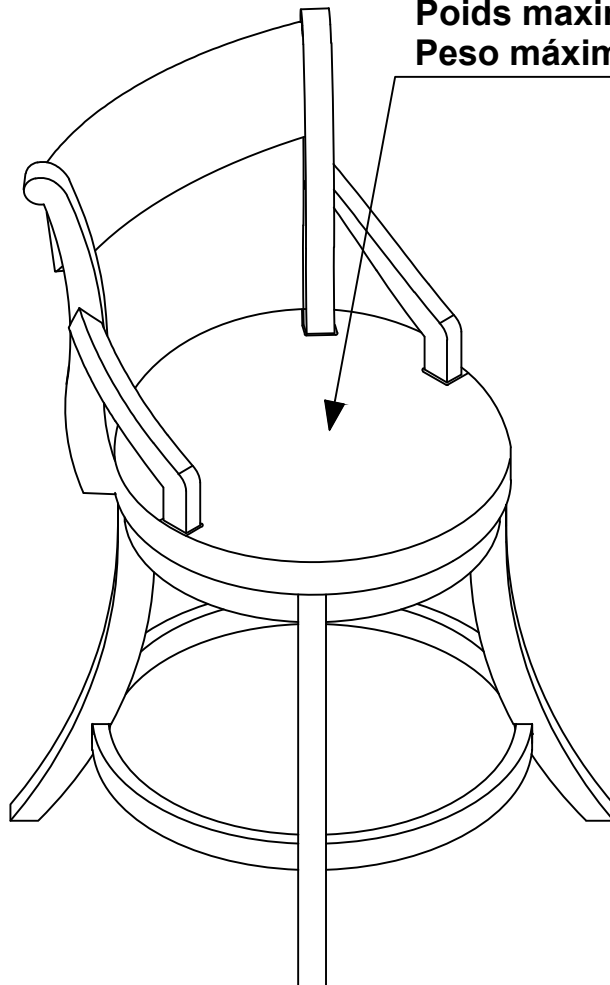

---

# **LIMITED 6 MONTHS WARRANTY**

# **GARANTIE LIMITEÉ DE 6 MOIS**

# **GARANTÍA LIMITADA DE 6 MESES**

## **WHAT IS COVERED**

This product is covered under our manufacturer's 6 months limited warranty (L.Powell Acquisition Corp.). To ensure your complete satisfaction, this warrants to the original purchaser that the Powell supplied item is free from defects in material and workmanship, as of the date of purchase, and that it will, under normal use and proper care, remain so for six months after the date of purchase.

Replacement of missing or initially defective parts will be sent, at no charge, for a period of 30 days from the date of purchase with valid proof of purchase providing the parts are available in our warehouse and the item purchase is part of our current inventory.

## **WHAT IS COVERED**

It remains the customer's responsibility for freight and packaging charges to and from the customer service center. Labor and material changes to remove or replace parts under this warranty are not covered

This warranty are not covered: Furniture used for commercial purposes, failures caused by improper installation assembly or by improper damage, acts of God, rust, purchase parts or return freight and packaging charges. Proof of purchase( date register receipt) is required for warranty claims.

## **QU'EST-CE QUI EST COUVERT**

Ce produit est couvert sous une garantie limitée de 6 mois offerte par le fabricant. Afin d'assurer votre entière satisfaction, cela garantit à l'acheteur original que le produit fourni est exempt de la date d'achat, et ce, sous des conditions d'utilisation normales et de soins adéquats, valide pendant six mois après la date d'achat.

Le remplacement de pièces manquantes ou défectueuses dès le départ sera envoyé, sans frais, pour une période de 30 jours suivant la date d'achat avec une preuve d'achat valide pourvu que les pièces soient disponibles dans notre entrepôt et que l'article acheté fait partie de notre inventaire actuel.

## **QU'EST-CE QUI N'EST PAS COUVERT**

Il y a de la responsabilité de client de couvrir les frais de transport et d'emballage vers et à partir du centre de service après-vente. Les frais de la main-d'œuvre et des matériaux pour retirer les pièces ou les remplacer sous cette garantie ne sont pas couverts.

Cette garantie ne couvre pas: les meubles utilisés à des fins commerciales, les défaillances causées par un mauvais assemblage ou entretien (sans dépasser les limites de poids), l'utilisation déraisonnable ou abusive, les frais de transport et d'emballage pour des pièces achetées ou retournées. Une preuve d'achat (recu de caisse date) est requise pour les réclamations sous garantie.

## **QUÉ ESTÁ CUBIERO**

Este producto está cubierto por la garantía limitada de 6 meses de nuestro fabricante. Para asegurar su total satisfacción, esta garantiza al comprador original que el artículo proporcionado se encuentra libre de defectos materiales y de fabricación, a partir de la fecha de compra, y que permanecerá en el estado, durante los seis meses posteriores a la fecha de la compra.

Las partes faltantes o que presenten defectos al inicio de ese periodo de tiempo serán enviadas sin cargo, durante un lapso de 30 días a partir de la fecha de compra, mediante la presentación de un comprobante de compra válido, siempre que las partes estén disponibles en nuestro almacén y el artículo adquirido sea parte de nuestro inventario actual.

## **QUÉ NO ESTÁ CUBIERTO**

Il y a de la responsabilité de client de couvrir les frais de transport et d'emballage vers et à partir du centre de service après-vente. Les frais de la main-d'œuvre et des matériaux pour retirer les pièces ou les remplacer sous cette garantie ne sont pas couverts.

Cette garantie ne couvre pas: les meubles utilisés à des fins commerciales, les défaillances causées par un mauvais assemblage ou entretien (sans dépasser les limites de poids), l'utilisation déraisonnable ou abusive, les frais de transport et d'emballage pour des pièces achetées ou retournées. Une preuve d'achat (recu de caisse date) est requise pour les réclamations sous garantie.