

INSTALLATION INSTRUCTIONS

*The vessel and faucet set is not included

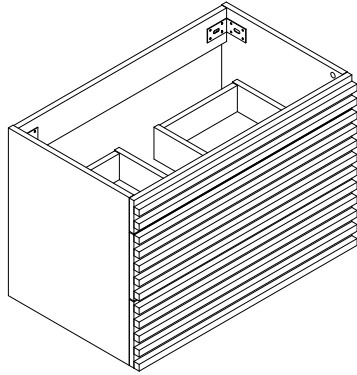

ASSEMBLY DIAGRAM

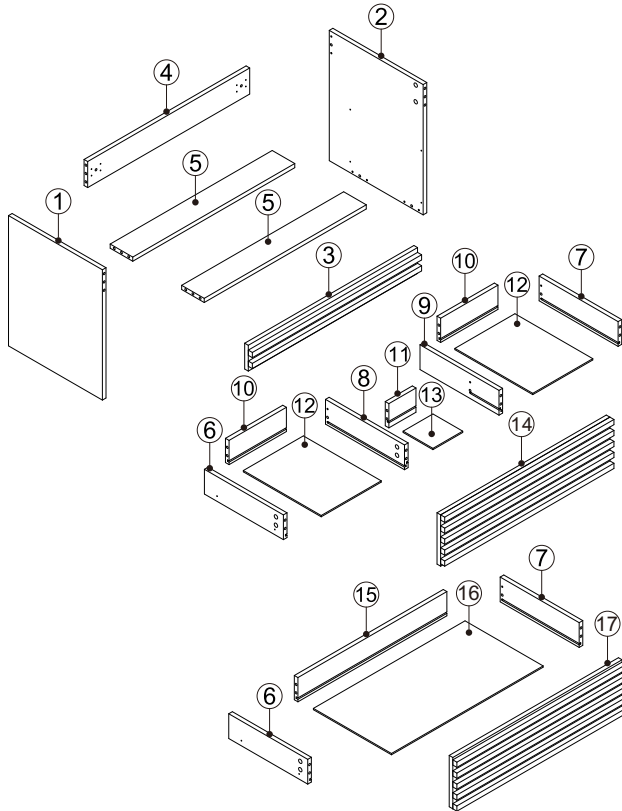

YOU MAY NEED (NOT SUPPLIED)

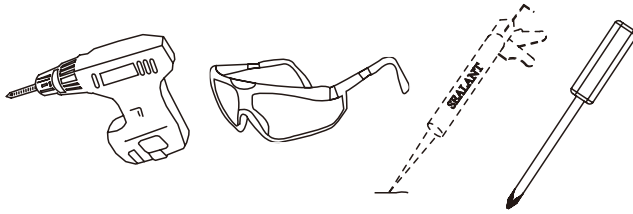

INSTALLATIONS

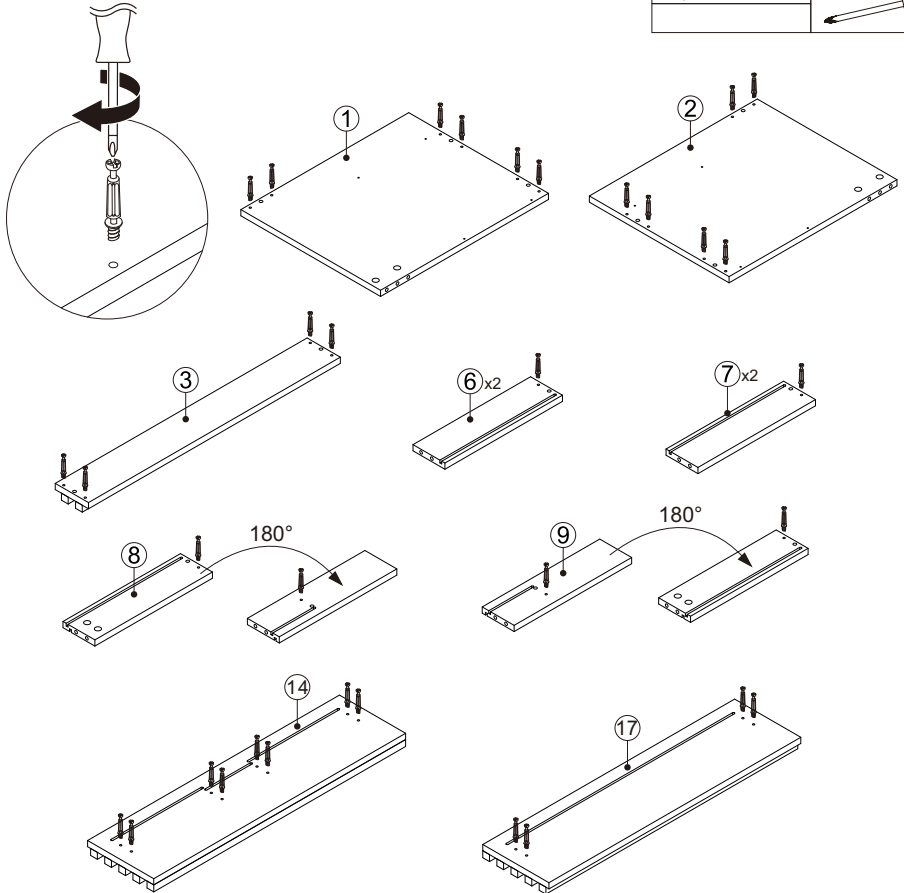

STEP 1

HARDWARE LIST	
A 	36PCS



- Insert the Cam Screw into the shelves above.

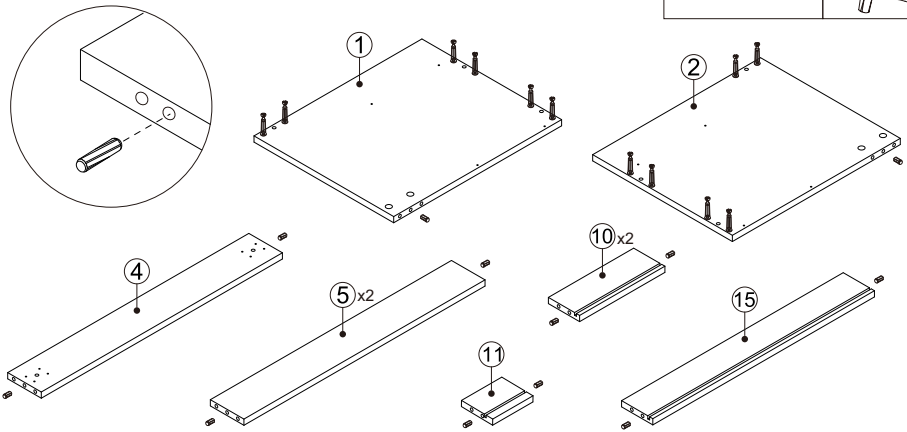

STEP 2

HARDWARE LIST		
B		16PCS
		



- Insert the wooden dowel pins into the shelves.

STEP 3

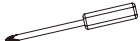
HARDWARE LIST		
D		4PCS
C		12PCS
		

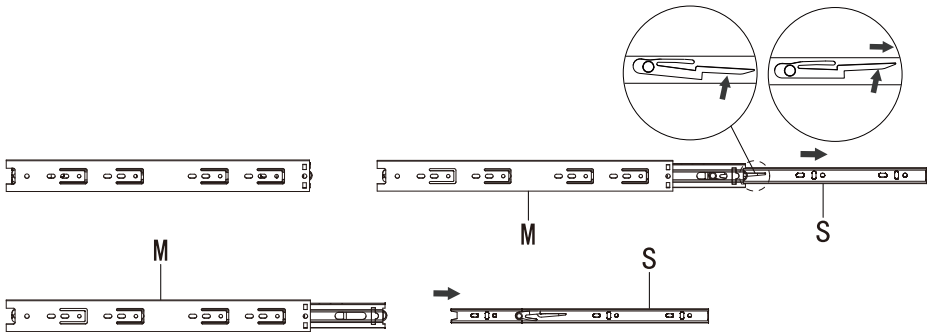

- Keep pressing here, then pull out to divide the slide.

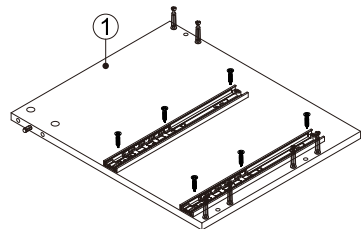
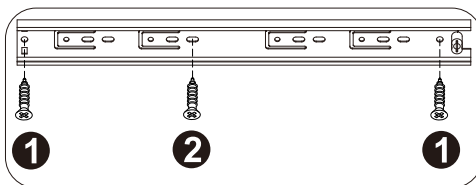

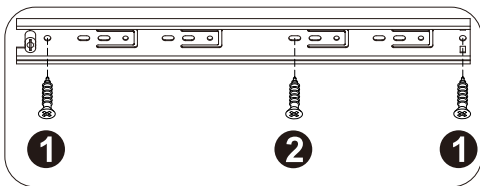
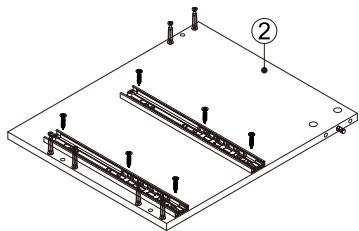

- Refer to the illustration, to fix the slide rails to the board #1,#2 with screws.

STEP 4

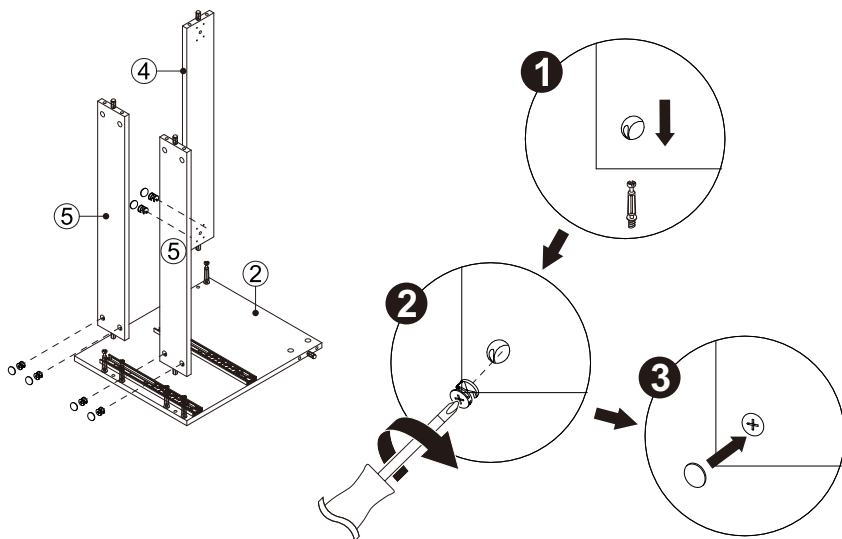

HARDWARE LIST		
A		6PCS
A		6PCS



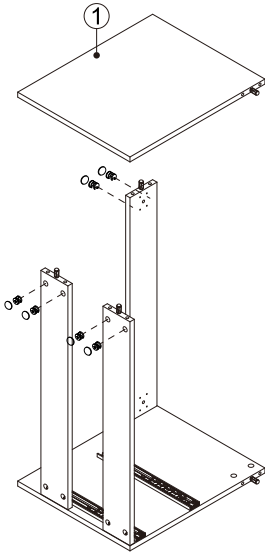

- Refer to the illustration, insert the shelves #4,#5 on the shelf #2. Then tighten the cam lock with the cover.

STEP 5



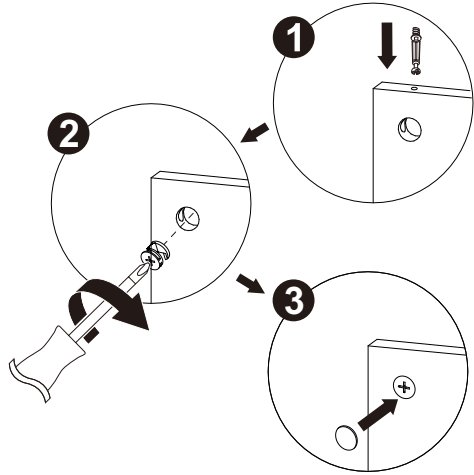
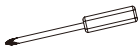

HARDWARE LIST		
A		6PCS
A		6PCS

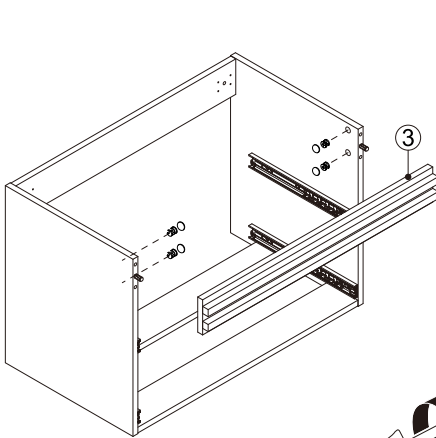

- Refer to the illustration, Install shelf #1 on the cabinet. Then tighten the cam lock with the cover.

STEP 6



HARDWARE LIST		
A		4PCS
A		4PCS

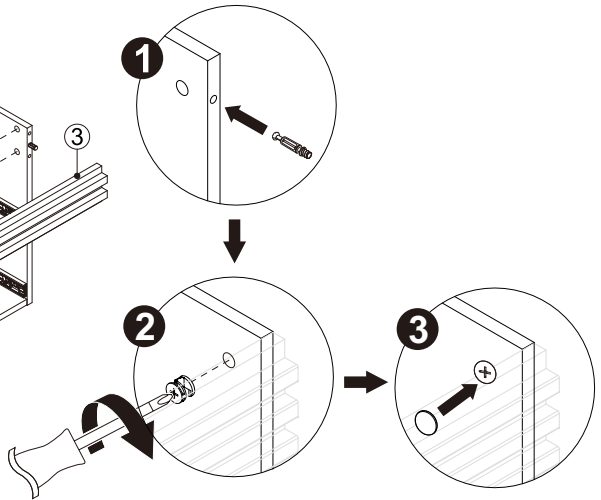
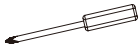

- Refer to the illustration, insert the #3 into the assembled shelf as well. Then tighten the cam lock with the cover.

STEP 7

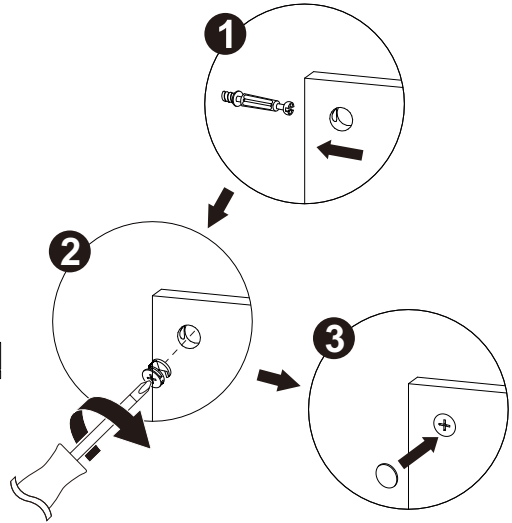
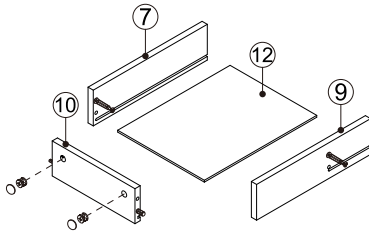
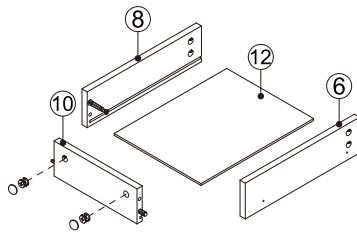

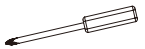

HARDWARE LIST		
A		4PCS
A		4PCS

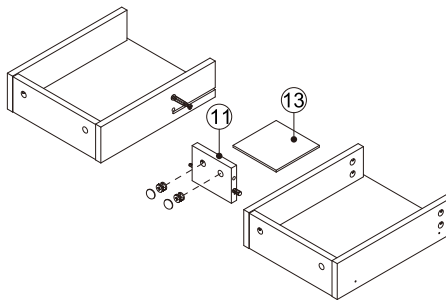

- Refer to the illustration, connect the plates #6,#8,#10 #12 together,connect the plates #7,#9,#10,#12 together, Then tighten the cam lock with the cover.

STEP 8



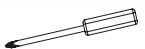

HARDWARE LIST		
A		2PCS
A		2PCS



- Connect the assembled shelves to the plate #11,#13 together,then tighten the cam lock with the cover.

STEP 9

HARDWARE LIST		
A		8PCS
A		8PCS

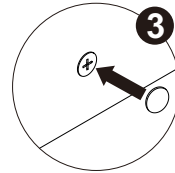
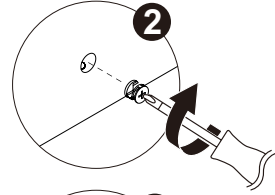
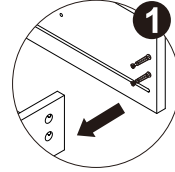
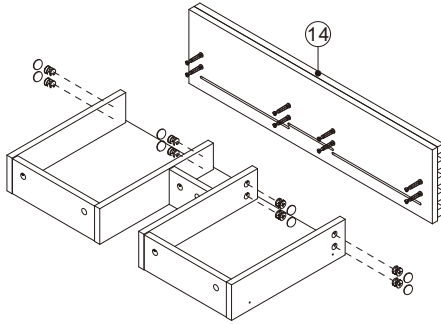

- Refer to the illustration, draw the panel #14 is inserted into the prepared plate. Then tighten the cam lock with the cover.

STEP 10

HARDWARE LIST		
D		2PCS
C		6PCS

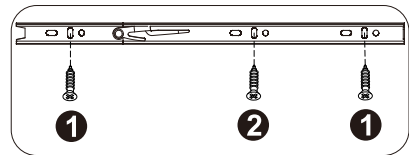
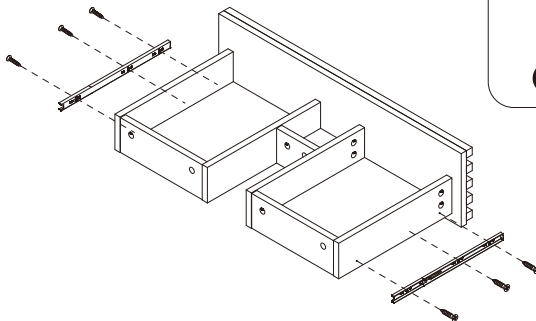

- Refer to the illustration, Apply screws to fix the slides on the boards #6,#7.

STEP 11

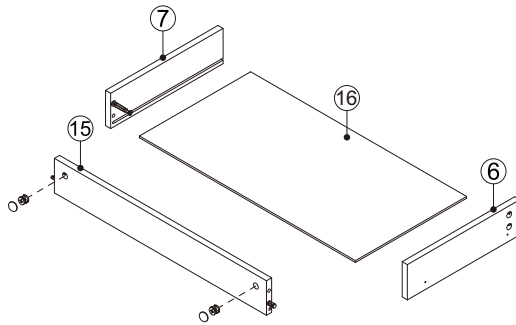

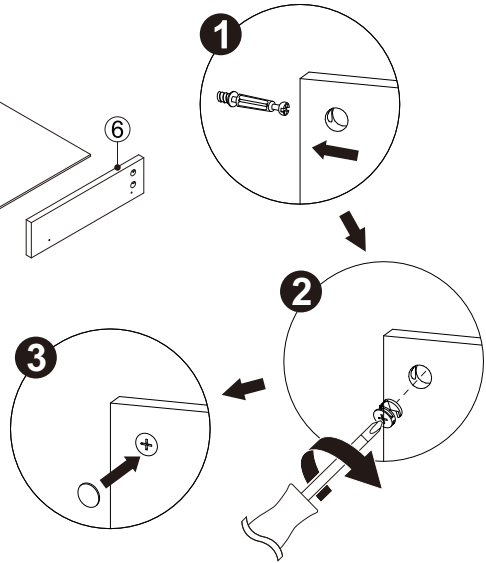
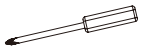

HARDWARE LIST		
A		2PCS
A		2PCS

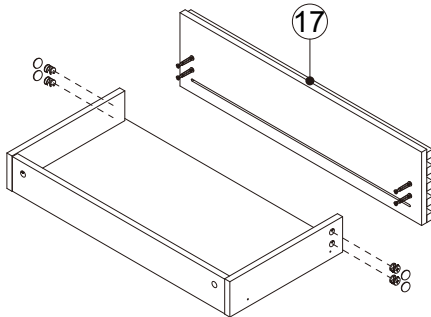

- Refer to the illustration, connect the plates #6,#7, #15,#16 together, Then tighten the cam lock with the cover.

STEP 12



HARDWARE LIST		
A		4PCS
A		4PCS

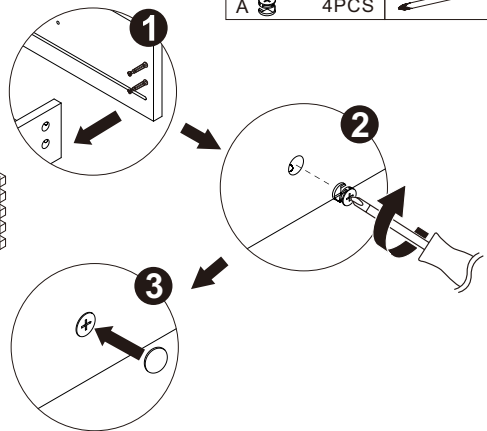

- Refer to the illustration, draw the panel #17 is inserted into the prepared plate. Then tighten the cam lock with the cover.

STEP 13

HARDWARE LIST		
D		2PCS
C		6PCS

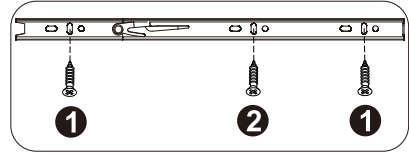
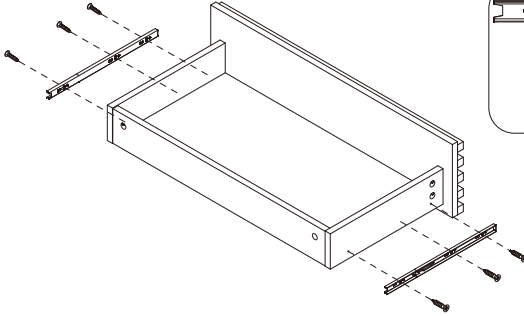

- Refer to the illustration, Apply screws to fix the slides on the boards #6,#7.

STEP 14



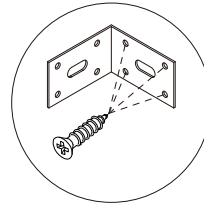
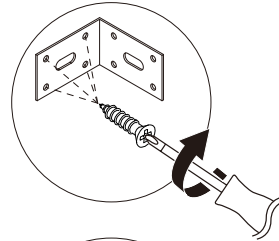
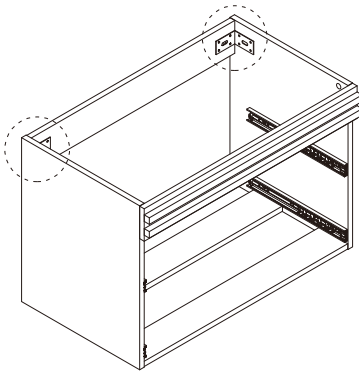

HARDWARE LIST		
C		16PCS
F		2PCS

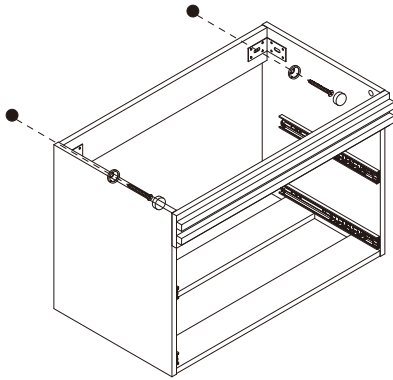

- Refer to the illustration,use screws to secure the bracket to the plate.

STEP 15



HARDWARE LIST		
E		2PCS
E		2PCS
E		2PCS
E		2PCS

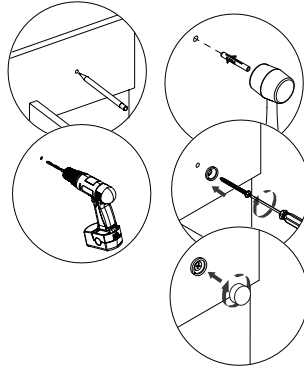

- Refer to the illustration, draw the spacing between the walls on the cabinet, punch holes in the wall, and fix the cabinet to the wall with screws. Then tighten the nut cover.

STEP 16

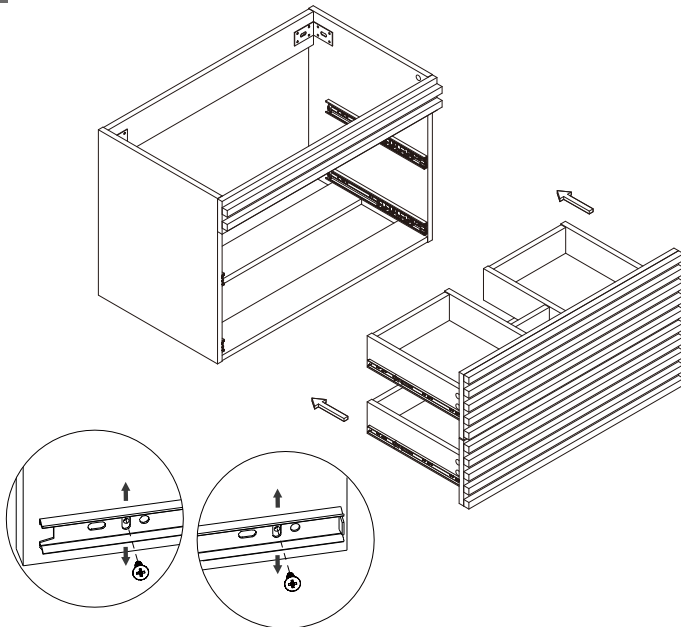

- If the drawers are not in the same level, please adjust the screws in the drawer box.
- Assembled drawers are loaded onto cabinets.

STEP 17

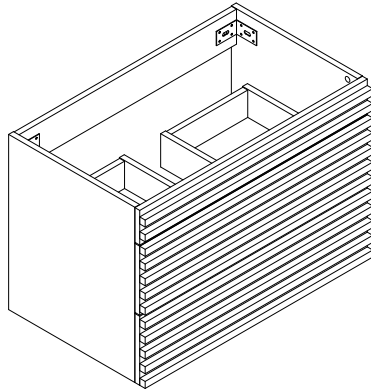

- To help prevent mildew, apply sealant to the space between the wall and the edge of the cabinet.

CARE AND CLEANING

1. Many cleansers contain abrasive and chemical substance which is not suitable for cleaning stainless steel, enamel, plating or plastic products. You may use mild cleansers or soaps to clean the surfaces. Wipe any splashes of cleaner solutions from the surface with a clean soft cloth.
2. Maintain ventilation in the bathroom and separate the dry area from the damp one if conditions permit. Try to open the door and windows of the bathroom to maintain adequate ventilation.
3. This cabinet is built to withstand normal bathroom humidity. For best results, keep this vanity dry and take necessary steps to minimize bathroom humidity by opening windows and doors and using the exhaust fan (if available).
4. To maintain the cabinet door, clean and wipe the door regularly with a soft cloth. Wipe condensation with a dry, soft cloth. Keep away from fires and high temperatures.
5. Please do not sit, lean or step on the basin cabinet.

FEEDBACK ★★★★★

Thank you very much for purchasing from us.

We have always been trying to provide the best service and reliable products for every customer.

We sincerely hope you will be satisfied with our products and leave us FIVE STARS and POSITIVE feedback/review in our page.

However, accident may happen sometimes, please contact us to resolve any issue before leaving a negative feedback.

Many thanks and welcome to our shop again!