

# Folie S/70.2

Design / Diseño:  
Christophe Mathieu / 2022

Typology: Pendant lamp  
Tipología: Suspensión

Environment: Indoor  
Ambiente: Interior

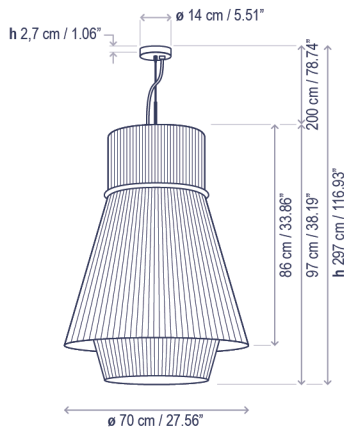

## Technical description / Descripción técnica:

 Net Weight: 16.53 lbs  
Peso Neto: 16.53 lbs

 1 Box/Caja  
34.65 x 34.65 x 55.51 inches | 38.5601 ft<sup>3</sup>  
Gross Weight / Peso bruto: 27.56 lbs

Materials: Steel, Aluminum  
Materiales: Acero, Aluminio

Diffuser: Polycarbonate  
Difusor: Policarbonato

Shade GWFI: 960°  
Hilo incandescente pantalla: 960°

Customizable: consult  
Personalizable: consultar

Bulbs not included  
Bombillas no incluidas

Certifications  
Certificaciones   

## Lamps description / Descripción lámpara:

 120V  
60Hz | DRY | IP-20 |  MAX. 5 x 16 W E26 LED A19 | 

Ref	Finishing / Acabados	Ean13
20602202182U	Black - White Translucent Ribbon Shade Negro - Pantalla Cinta Translúcida Blanca	8435493703558
20602202183U	Black - Cream Translucent Ribbon Shade Negro - Pantalla Cinta Translúcida Crema	8435493703534

**bover**  
barcelona lights

1251 Collier Road,  
Suite C  
Atlanta, GA 30318  
United States

T. +1 (404) 924 2342  
info@boverusa.com  
www.boverusa.com

## Family / Familia: Folie

