

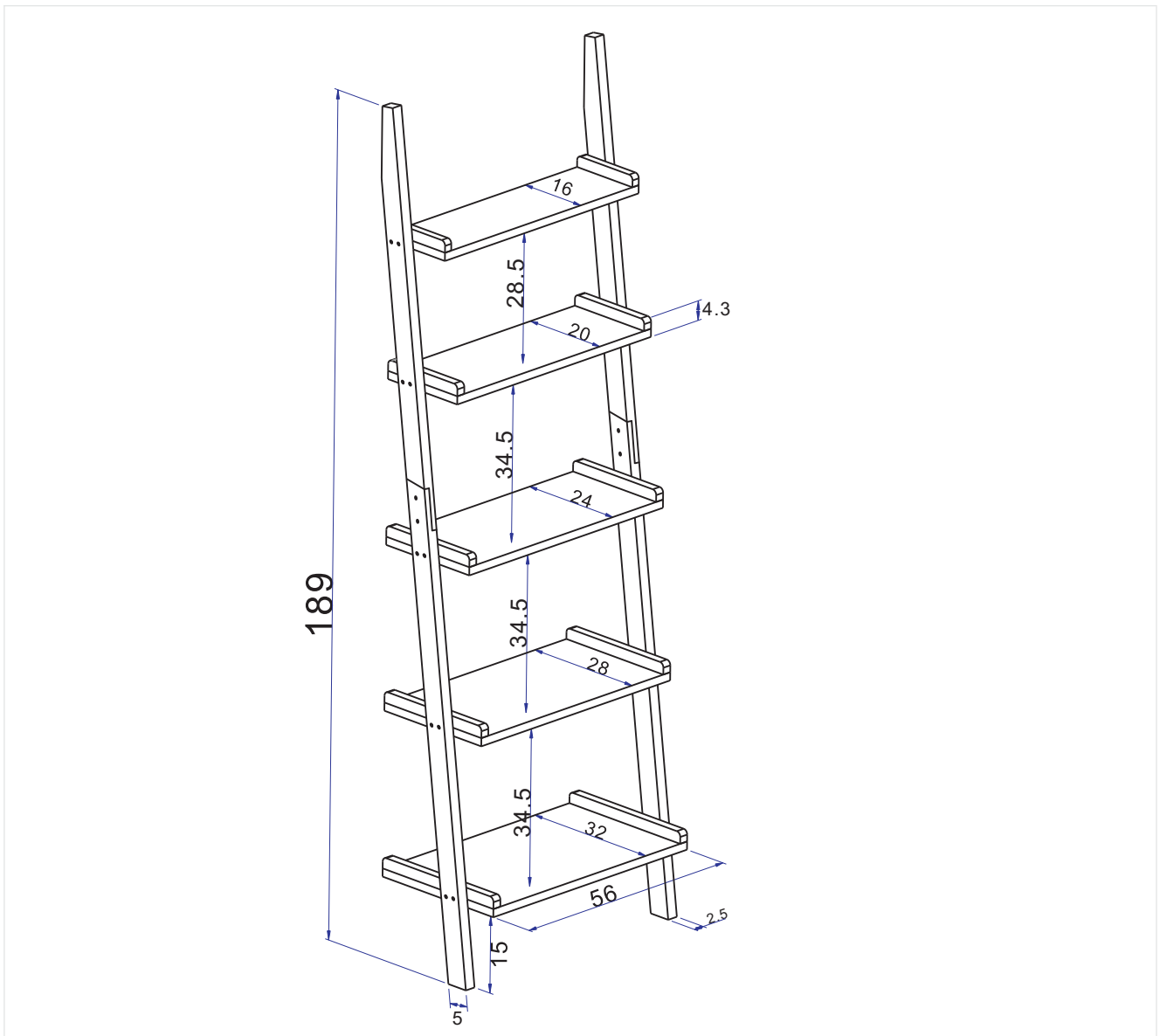

LADDER SHELF

Assembly Instructions – Please keep for future reference



Dimensions	No. people	Assembly Time	
Width: 100cm Depth: 50cm Height: 72cm		90 mins (approx.)	

Important – Please read these instructions fully before starting assembly

Safety and Care Advice

Important – Please read these instructions fully before starting assembly

- ξ Check you have all the components and tools listed on pages 2, 3 and 4.
- ξ Remove all fittings from the plastic bags and separate them into their groups.
- ξ Keep children and animals away from the work area, small parts could choke if swallowed.
- ξ Make sure you have enough space to lay out the parts before starting.
- ξ Do not stand or put weight on the product, this could cause damage.
- ξ Assemble the item as close to its final position (in the same room) as possible.
- ξ Assemble on a soft, level surface to avoid damaging the unit or your floor.
- ξ We do not recommend the use of power drill/drivers for inserting screws, as this could damage the unit. Only use hand screwdrivers.
- ξ Dispose of all packaging carefully and responsibly.



Care and Maintenance

- ξ Only clean using a damp cloth and mild detergent, do not use bleach or abrasive cleaners.
- ξ From time to time check that there are no loose screws on this unit.
- ξ This product should not be discarded with household waste. Take to your local authority waste disposal centre.

If you are unhappy with the product and wish to return it, please follow the retailer's returns procedure.



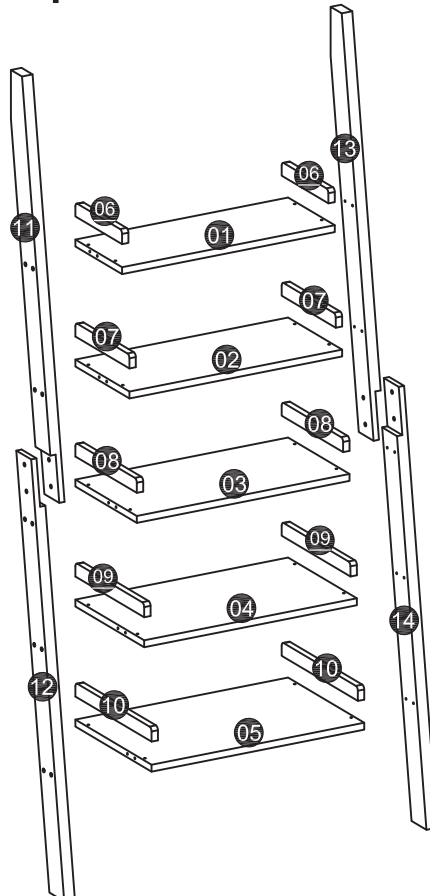





Components - Panels

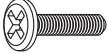

Components - Fixings

Please check that you have all the components listed below before constructing your item.

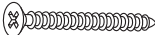
Note: The quantities below are the correct amount to complete the assembly. In some cases more fittings may be supplied than are required.

(A)	 Ø4 x50mm X20	(B)	 X20	(C)	 M6 x15mm X4	(D)	 Nut X4
(E)	 Ø4 x30mm X20	(F)	 Expansion bolt X2	(G)	 Ø4x40mm X2	(H)	 Corner iron X2
(I)	 Screw X2						

Tools Required (Not Provided)

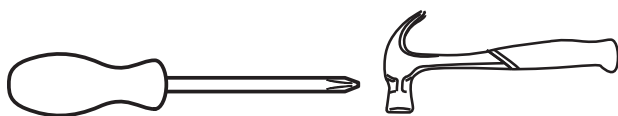

Ruler – Use this to measure your screws (mm)

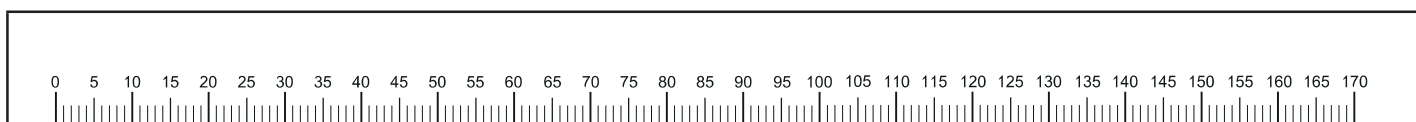

Important – Please read these instructions fully before starting assembly

Assembly Instructions

Step 1

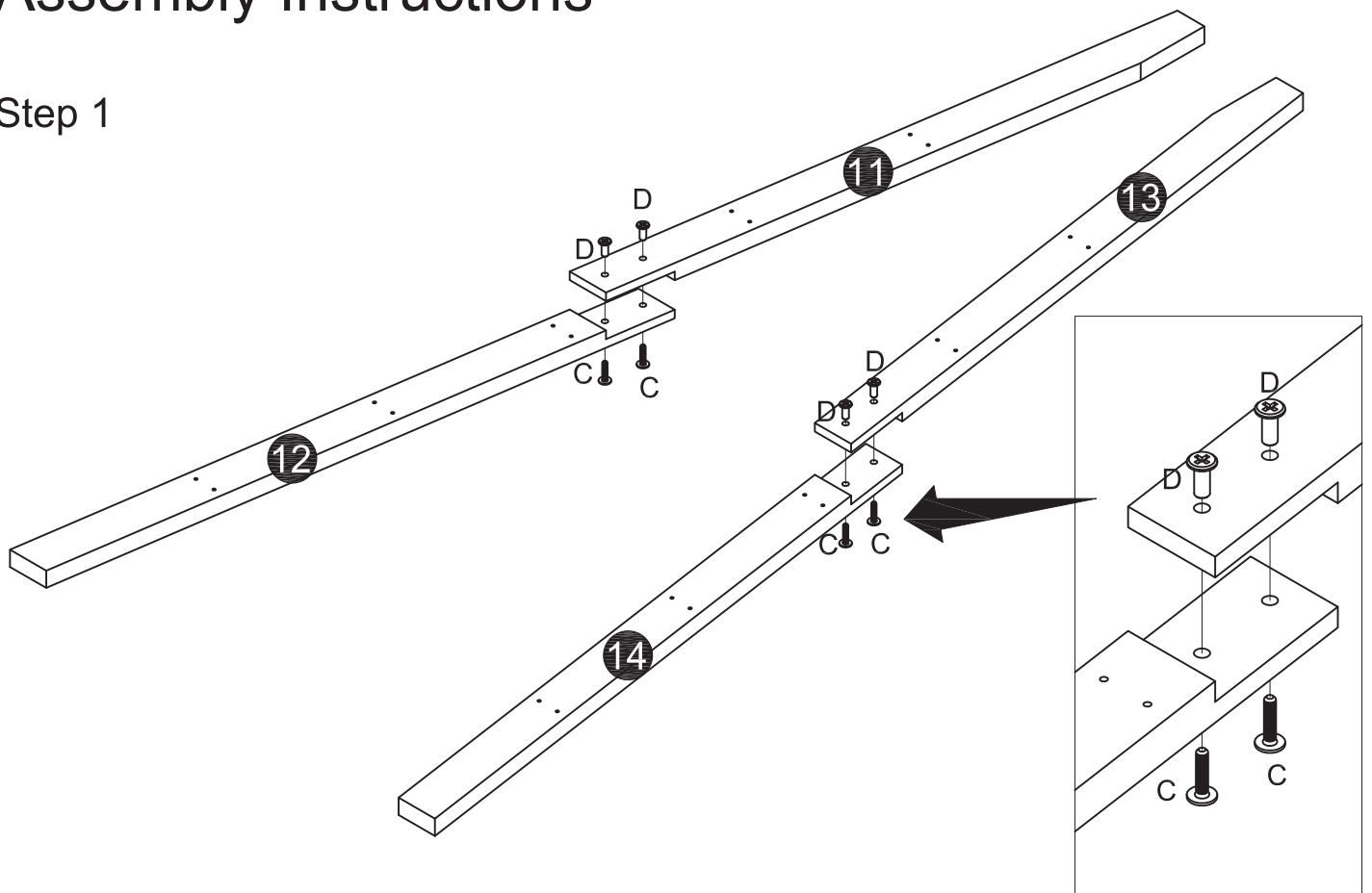

Step 2

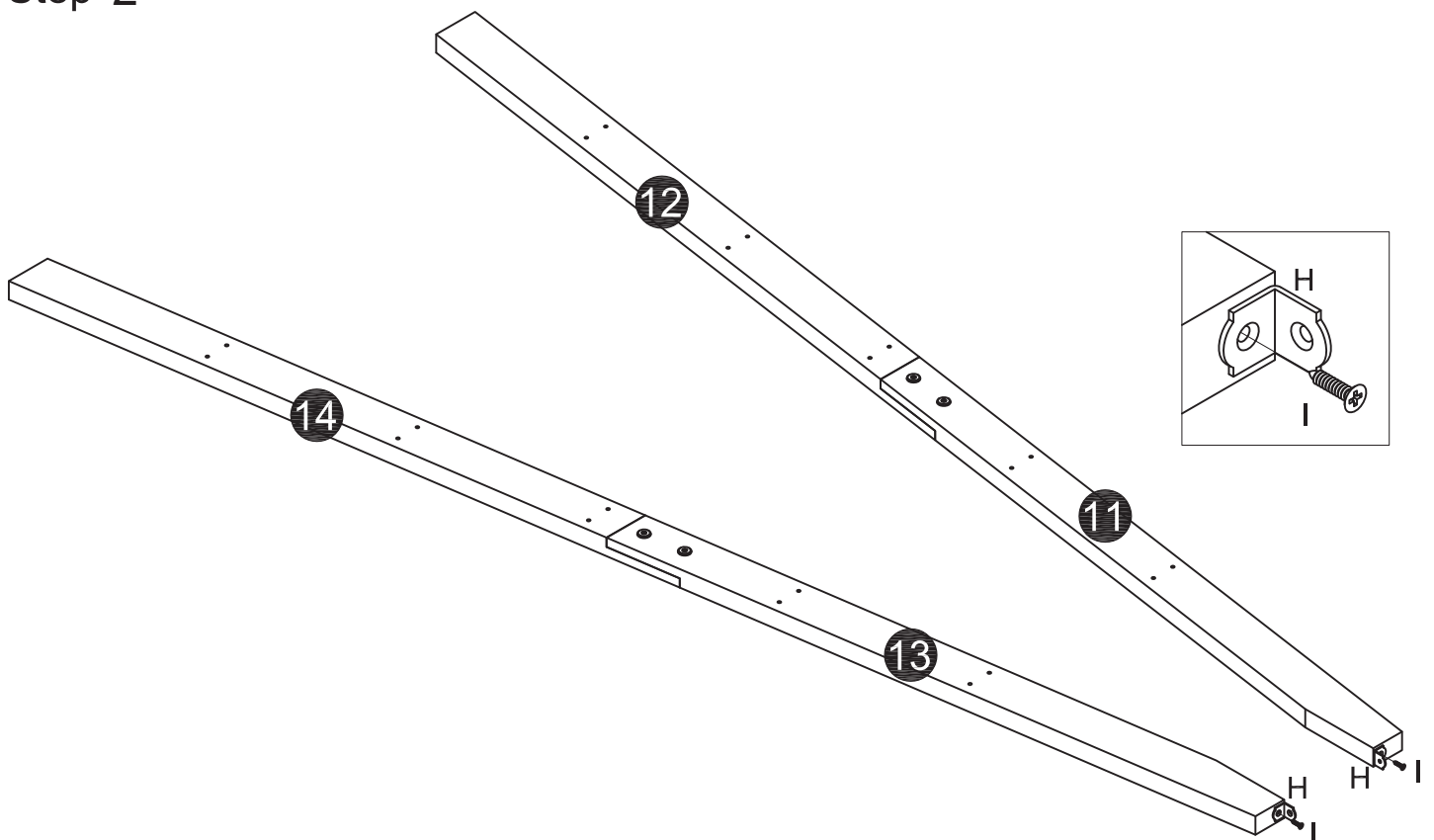

Step 3

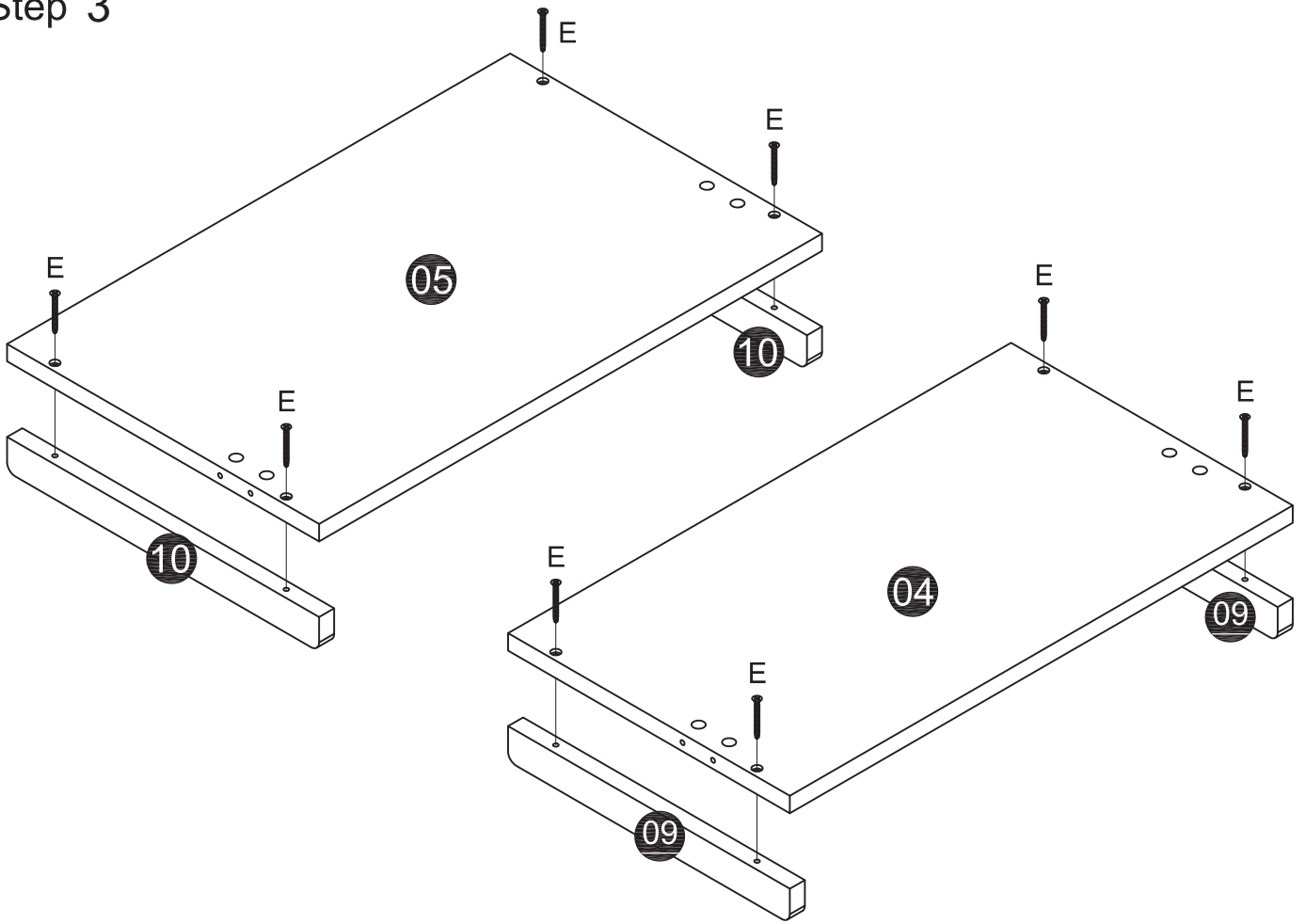

Step 4

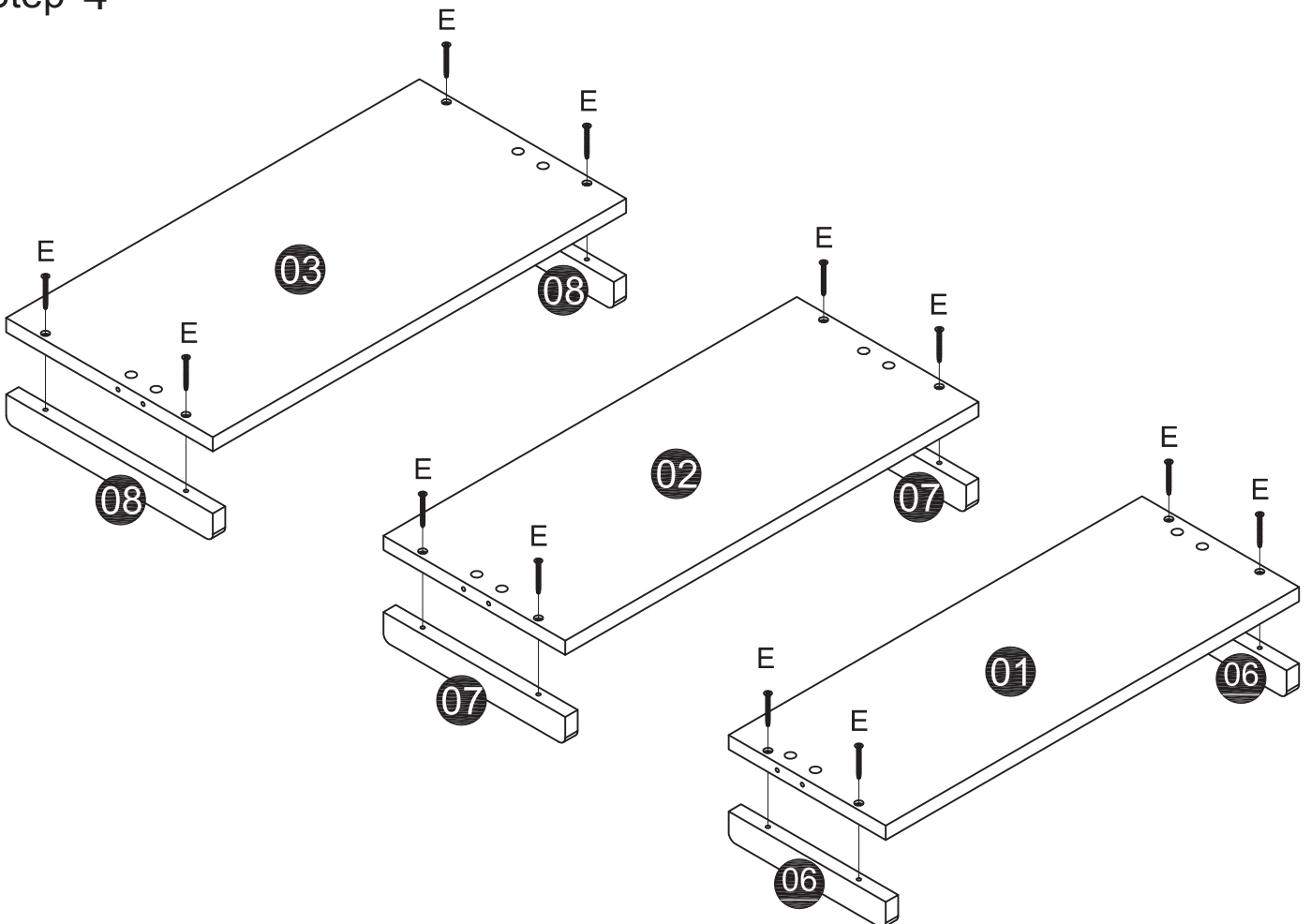

Step 5

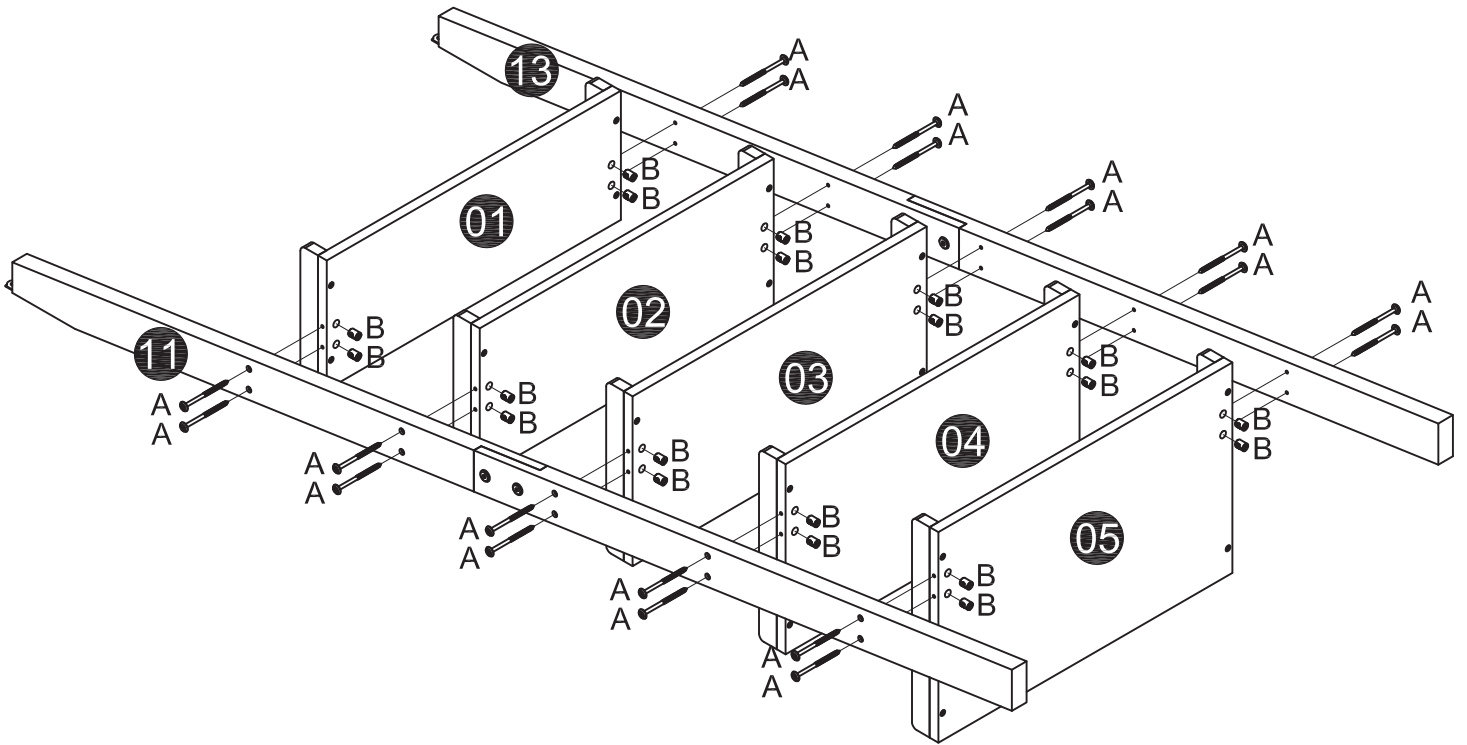

Step 6

