

Pure & Easy



# **ASSEMBLY INSTRUCTIONS**

# NOTICE

IMPORTANT, RETAIN FOR FUTURE REFERENCE: READ CAREFULLY  
WICHTIG, FÜR SPÄTERE NACHSCHLAGE AUFBEWAHREN: SORGFÄLTIG LESEN  
IMPORTANTE, GUARDAR PARA REFERENCIA POSTERIOR: LEER ATENTAMENTE  
IMPORTANTE, CONSERVARE PER RIFERIMENTI FUTURI: LEGGERE ATTENTAMENTE  
IMPORTANT, À CONSERVER POUR RÉFÉRENCE FUTURE : LIRE ATTENTIVEMENT

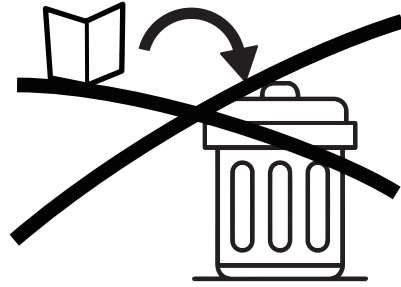
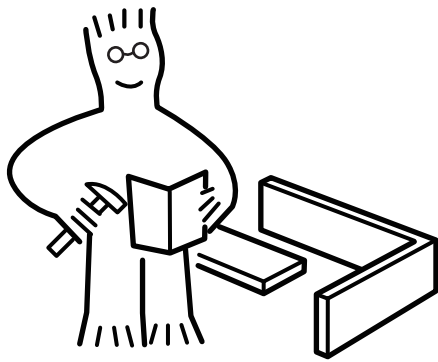

Assemble on a flat, clean and soft surface.  
Auf einer flachen, sauberen und weichen Oberfläche zusammenbauen.  
Assembler sur une surface plate, propre et douce.  
Assemblare su una superficie piatta, pulita e morbida.  
Ensamblar sobre una superficie plana, limpia y suave.

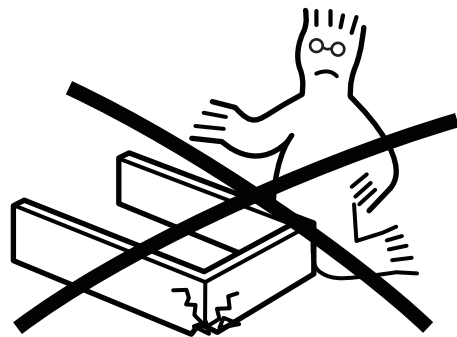
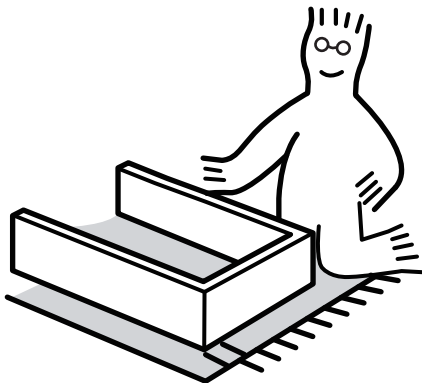

Professional installation is highly recommended.  
Eine professionelle Installation wird dringend empfohlen.  
Une installation professionnelle est fortement recommandée.  
Si raccomanda vivamente l'installazione professionale.  
Se recomienda altamente la instalación profesional.



Periodically Check That All Components Are Tightly Secured.  
Überprüfen Sie Regelmäßig, Dass Alle Komponenten Fest Gesichert Sind.  
Vérifiez Périodiquement Que Tous Les Composants Sont Bien Fixés.  
Controllare Periodicamente Che Tutti I Componenti Siano Ben Fissati.  
Verifique Periódicamente Que Todos Los Componentes Estén Bien Asegurados.



It is recommended that multiple people assemble this product.  
Es wird empfohlen, dass mehrere Personen dieses Produkt zusammenbauen.  
Il est recommandé que plusieurs personnes assemblent ce produit.  
Si raccomanda che più persone assemblino questo prodotto.  
Se recomienda que varias personas ensambren este producto.

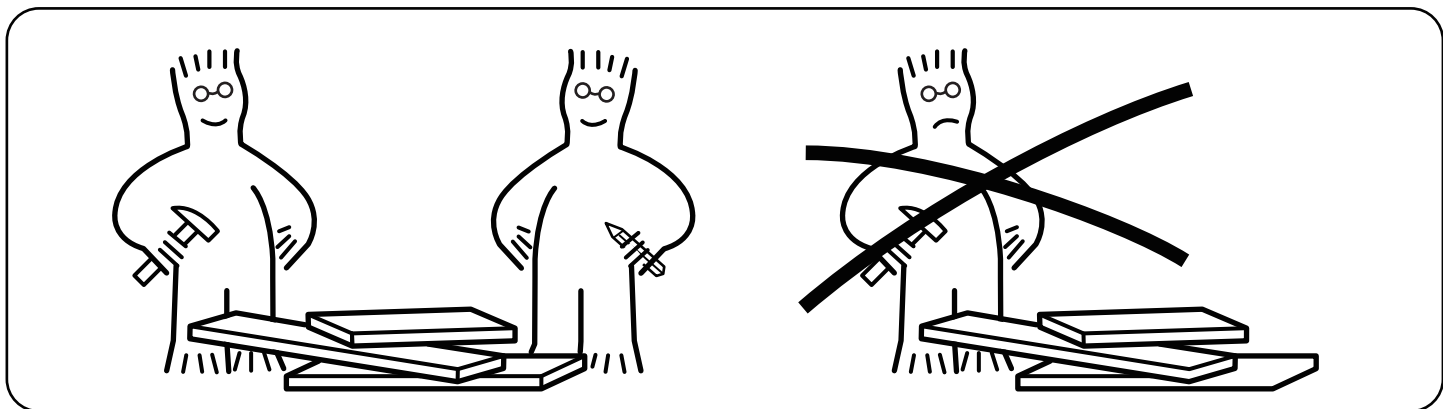

Please have the following auxiliary tools ready:  
Bitte halten Sie folgende Hilfswerkzeuge bereit:  
Veuillez préparer les outils auxiliaires suivants :  
Si prega di avere pronti i seguenti strumenti ausiliari:  
Por favor, tenga listas las siguientes herramientas auxiliares:

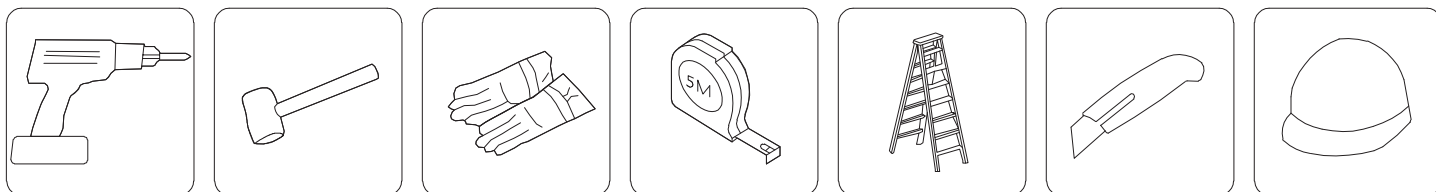

Assemble on a flat and solid surface. To avoid the unstable surface affecting the overall frame stability during installation.

Montieren Sie auf einer ebenen und festen Oberfläche. Um zu verhindern, dass eine unebene Oberfläche während der Montage die Gesamtrahmen-Stabilität beeinträchtigt.

Ensamblar en una superficie plana y sólida. Afin d'éviter que la surface inégale n'affecte la stabilité générale du cadre lors de l'installation.

Assemblare su una superficie piana e solida. Per evitare che una superficie irregolare influisca sulla stabilità complessiva della struttura durante l'installazione.

Assemble on a flat and solid surface. To avoid the unstable surface affecting the overall frame stability during installation.

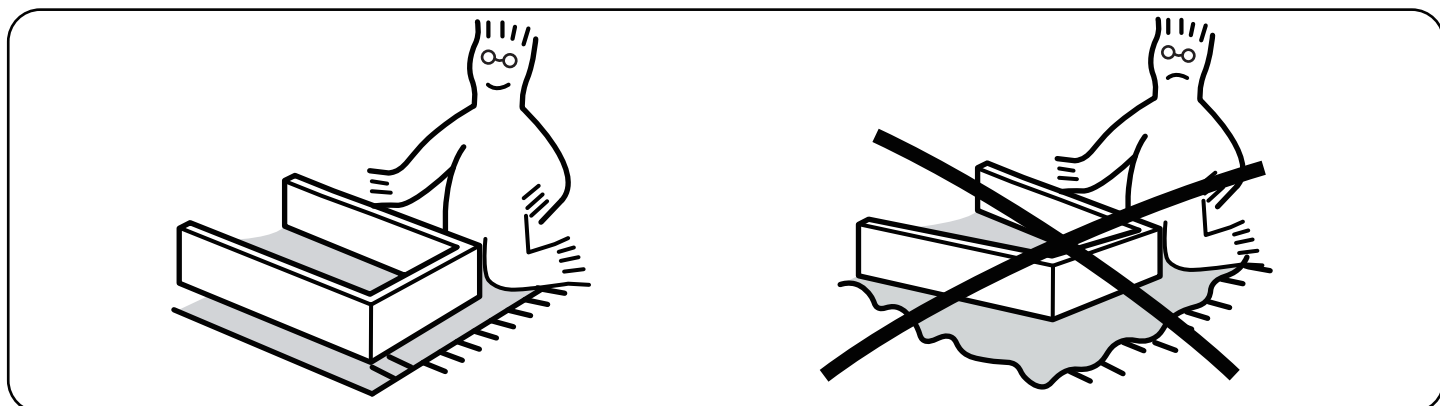

USING CAM LOCK AND QUICKFIT  
 VERWENDUNG VON NOCKENSCHLOSS UND QUICKFIT  
 UTILISATION DE SERRURE À CAME ET QUICKFIT  
 USO DI SERRATURA A LEVA E QUICKFIT  
 USANDO EL CIERRE DE LEVA Y QUICKFIT

Tighten QuickFit until the shoulder is flush with the panel. Do not overtighten or undertighten.  
 Ziehen Sie den Quickfit an, bis die Schulter bündig mit der Platte ist. Nicht zu fest oder zu locker anziehen.  
 Serrez le quickfit jusqu'à ce que l'épaulement soit affleurant avec le panneau. Ne serrez pas trop ou trop peu.  
 Stringere il quickfit fino a quando la spalla è a filo con il pannello. Non stringere troppo o troppo poco.  
 Apriete el quickfit hasta que el hombro esté al ras con el panel. No apriete demasiado ni demasiado poco.

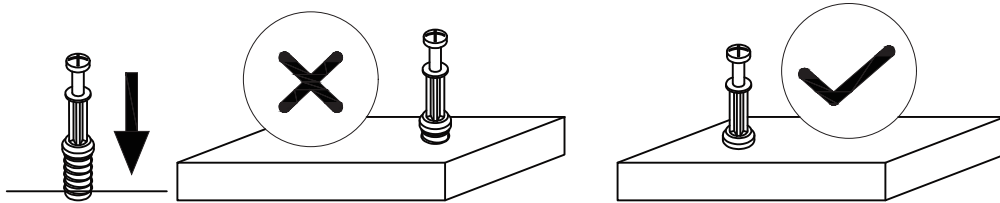

When fitting the cam lock, ensure the starting position is correct before inserting the connecting QuickFit.  
 Stellen Sie beim Einbau des nockenschloss sicher, dass die Startposition korrekt ist, bevor Sie den verbindenden Quickfit einsetzen.  
 Lors de la pose du serrure à came, assurez-vous que la position de départ est correcte avant d'insérer le quickfit de connexion.  
 Quando si monta il serratura a leva, assicurarsi che la posizione di partenza sia corretta prima di inserire il quickfit di collegamento.  
 Al instalar el cierre de leva, asegúrese de que la posición inicial sea correcta antes de insertar el quickfit de conexión.

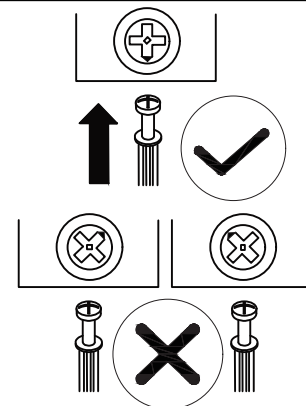

The QuickFit head should be in the center of the cam lock when the two panels are joined. The cam lock should be inserted before the QuickFit. Turn the cam lock clockwise to tighten.  
 Der Quickfit-Kopf sollte sich in der Mitte des nockenschloss befinden, wenn die beiden Platten verbunden sind. Der nockenschloss sollte vor dem Quickfit eingesetzt werden. Drehen Sie den nockenschloss im Uhrzeigersinn, um ihn zu befestigen.  
 La tête du quickfit doit être au centre du serrure à came lorsque les deux panneaux sont assemblés. Le serrure à came doit être inséré avant le quickfit. Tournez le serrure à came dans le sens des aiguilles d'une montre pour le serrer.  
 La testa del quickfit dovrebbe essere al centro del serratura a leva quando i due pannelli sono uniti. Il serratura a leva deve essere inserito prima del quickfit. Ruotare il serratura a leva in senso orario per stringere.  
 La cabeza del quickfit debe estar en el centro del cam lock cuando los dos paneles estén unidos. El cierre de leva debe insertarse antes del quickfit. Gire el cierre de leva en sentido horario para apretar.

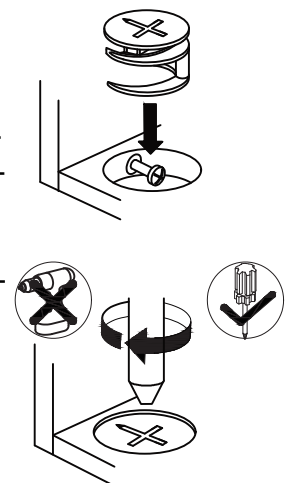





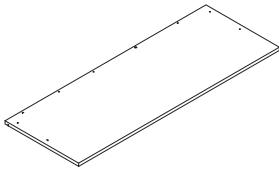
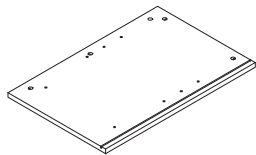
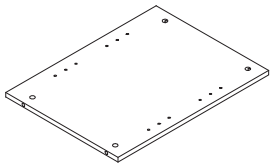
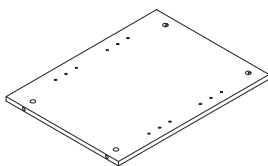
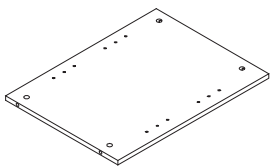
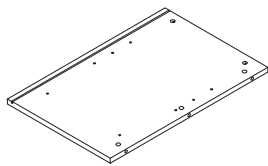

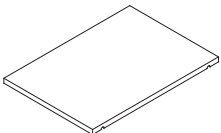
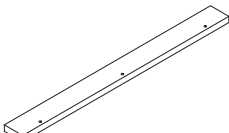
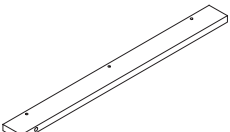
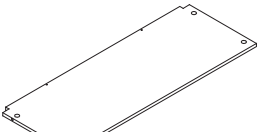
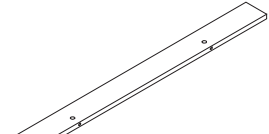
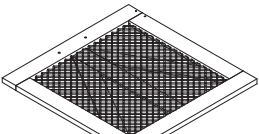
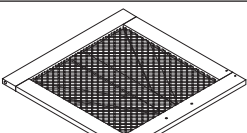
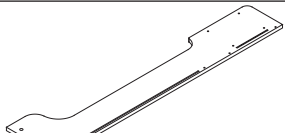
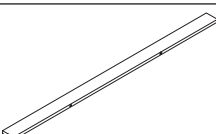
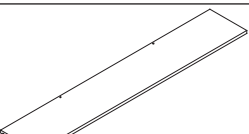
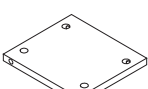
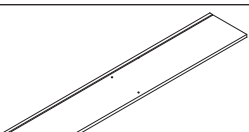
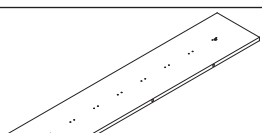
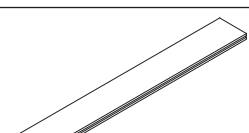
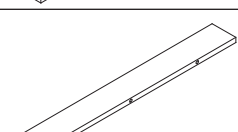
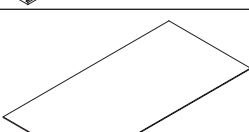
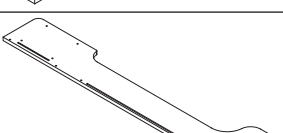
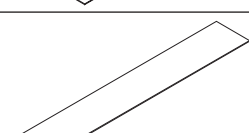
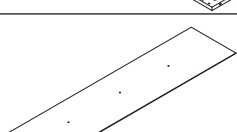

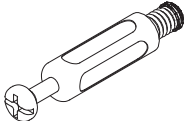
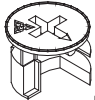
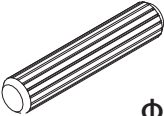
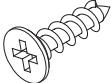
# PARTS

- ⚠**
1. Periodically check that all components are tightly secured.
  2. Assemble on a flat, clean, and soft surface.
  3. Confirm all parts are present prior to assembly.
  4. Prepare electric tools in advance for a quicker installation.
1. Prüfen Sie regelmäßig, ob alle Komponenten fest sitzen.
  2. Montieren Sie das Gerät auf einer ebenen, sauberen und weichen Oberfläche.
  3. Vergewissern Sie sich vor dem Zusammenbau, dass alle Teile vorhanden sind.
  4. Bereiten Sie Elektrowerkzeuge im Voraus vor, um eine schnellere Installation zu ermöglichen.
1. Vérifiez périodiquement que tous les composants sont bien fixés.
  2. Assemblez le tout sur une surface plane, propre et douce.
  3. Confirmez que toutes les pièces sont présentes avant l'assemblage.
  4. Préparez les outils électriques à l'avance pour une installation plus rapide.
1. Controllare periodicamente che tutti i componenti siano fissati saldamente.
  2. Assemblare su una superficie piana, pulita e morbida.
  3. Assicurarsi che siano presenti tutte le parti prima dell'assemblaggio.
  4. Preparare gli strumenti elettrici in anticipo per un'installazione più veloce.
1. Revise que todos los componentes estén asegurados con regularidad.
  2. Monte sobre una superficie que sea plana, limpia y suave.
  3. Antes de montar el producto, revise que tenga todas las piezas a mano.
  4. Para facilitar la instalación, prepare las herramientas eléctricas necesarias con tiempo.

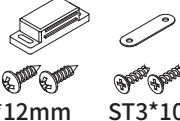
Item no. Nr. N° d'article Articolo No. Artículo No.	Reference Image Referenzbild Image de référence Immagine di riferimento Imagen de referencia	Qty. Menge Qté. Qtà Cant.	Item no. Nr. N° d'article Articolo No. Artículo No.	Reference Image Referenzbild Image de référence Immagine di riferimento Imagen de referencia	Qty. Menge Qté. Qtà Cant.
<b>1</b>		<b>X1</b>	<b>2</b>		<b>X1</b>
<b>3</b>		<b>X1</b>	<b>4</b>		<b>X1</b>
<b>5</b>		<b>X1</b>	<b>6</b>		<b>X1</b>

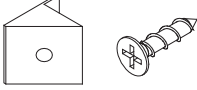
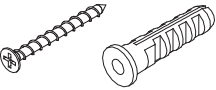
Item no. Nr. N° d'article Articolo No. Artículo No.	Reference Image Referenzbild Image de référence Immagine di riferimento Imagen de referencia	Qty. Menge Qté. Qtà Cant.	Item no. Nr. N° d'article Articolo No. Artículo No.	Reference Image Referenzbild Image de référence Immagine di riferimento Imagen de referencia	Qty. Menge Qté. Qtà Cant.
7		X6	8		X1
9		X1	10		X1
11		X1	12		X1
13		X1	14		X1
15		X1	16		X1
17		X1	18		X1
19		X1	20		X1
21		X1	22		X2
23		X1	24		X1
25		X2			

Item no. Nr. N° d'article Articolo No. Artículo No.	Reference Image Referenzbild Image de référence Immagine di riferimento Imagen de referencia	Qty. Menge Qté. Qtà Cant.	Item no. Nr. N° d'article Articolo No. Artículo No.	Reference Image Referenzbild Image de référence Immagine di riferimento Imagen de referencia	Qty. Menge Qté. Qtà Cant.
<b>A</b>		X66 + 2extra	<b>B</b>	 φ12*10mm	X66 + 2extra
<b>C</b>	 φ8*30mm	X2	<b>D</b>	 ST3.5*14mm	X26 + 1extra
<b>E</b>		X2	<b>F</b>		X10
<b>G</b>		X4	<b>H</b>	 ST3*12mm ST3*10mm	X2
<b>I</b>		X66 + 1extra	<b>J</b>	 ST3*12mm	X6
<b>K</b>	 ST4*40mm	X2	<b>L</b>		X1
<b>M</b>		X24			

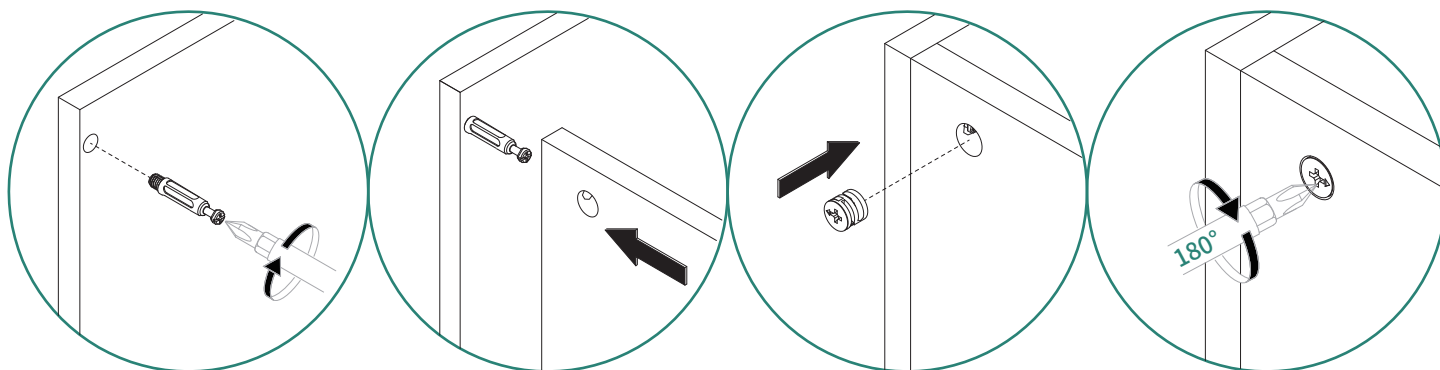

# EXPLODED VIEW

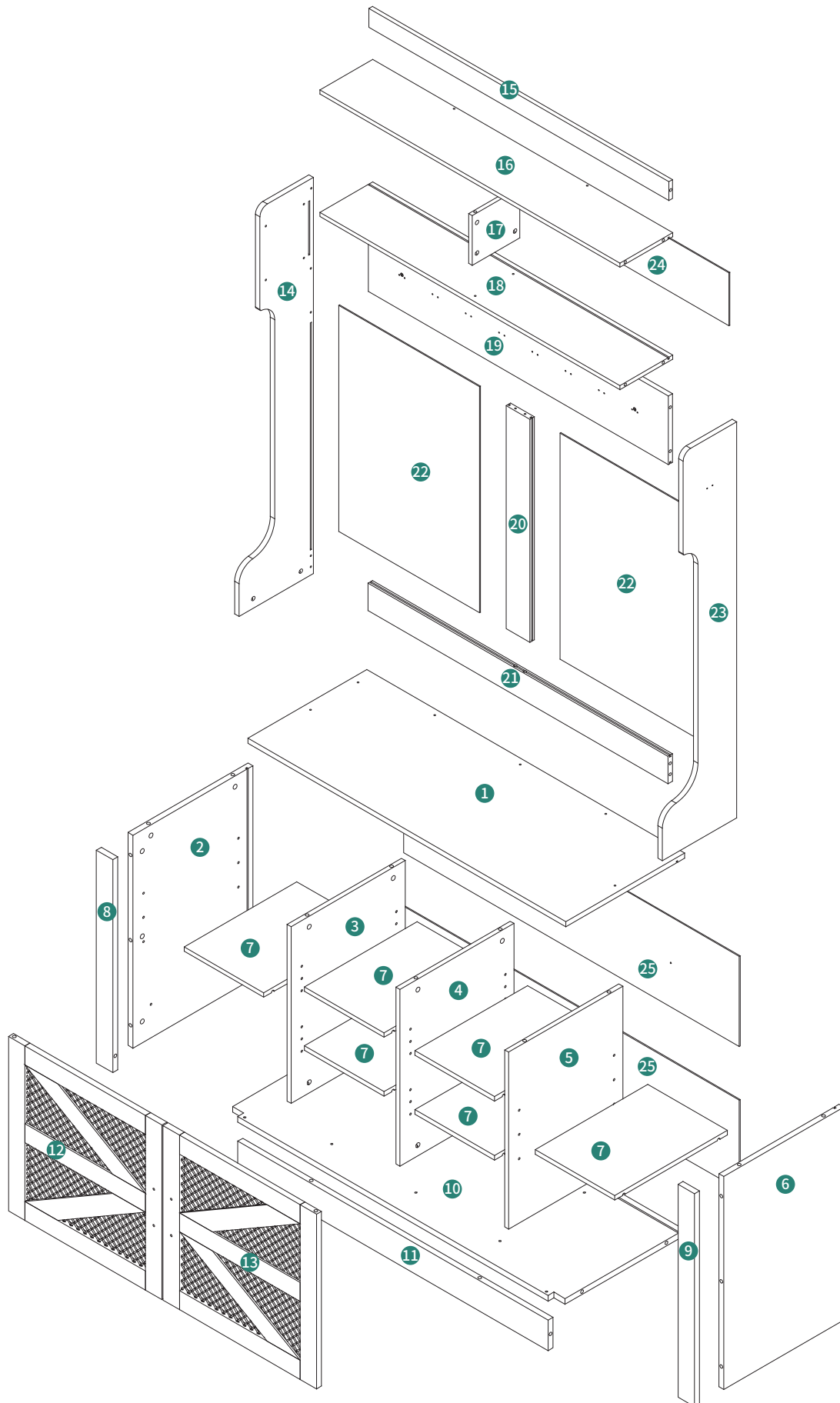

# ASSEMBLY

# 1

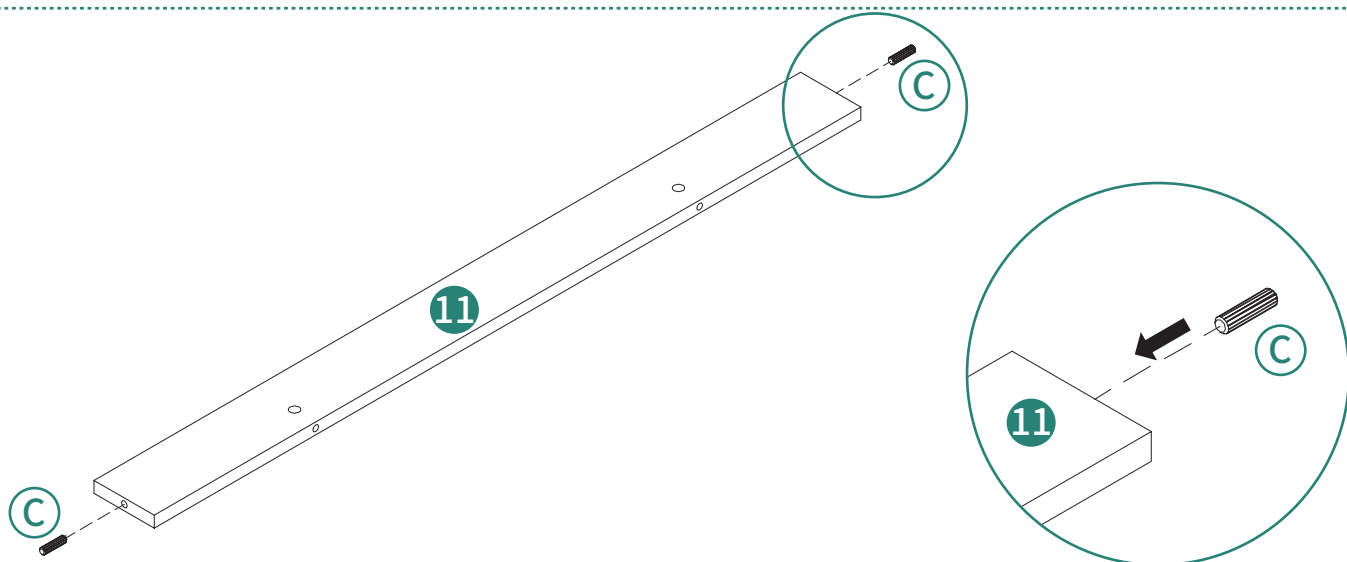
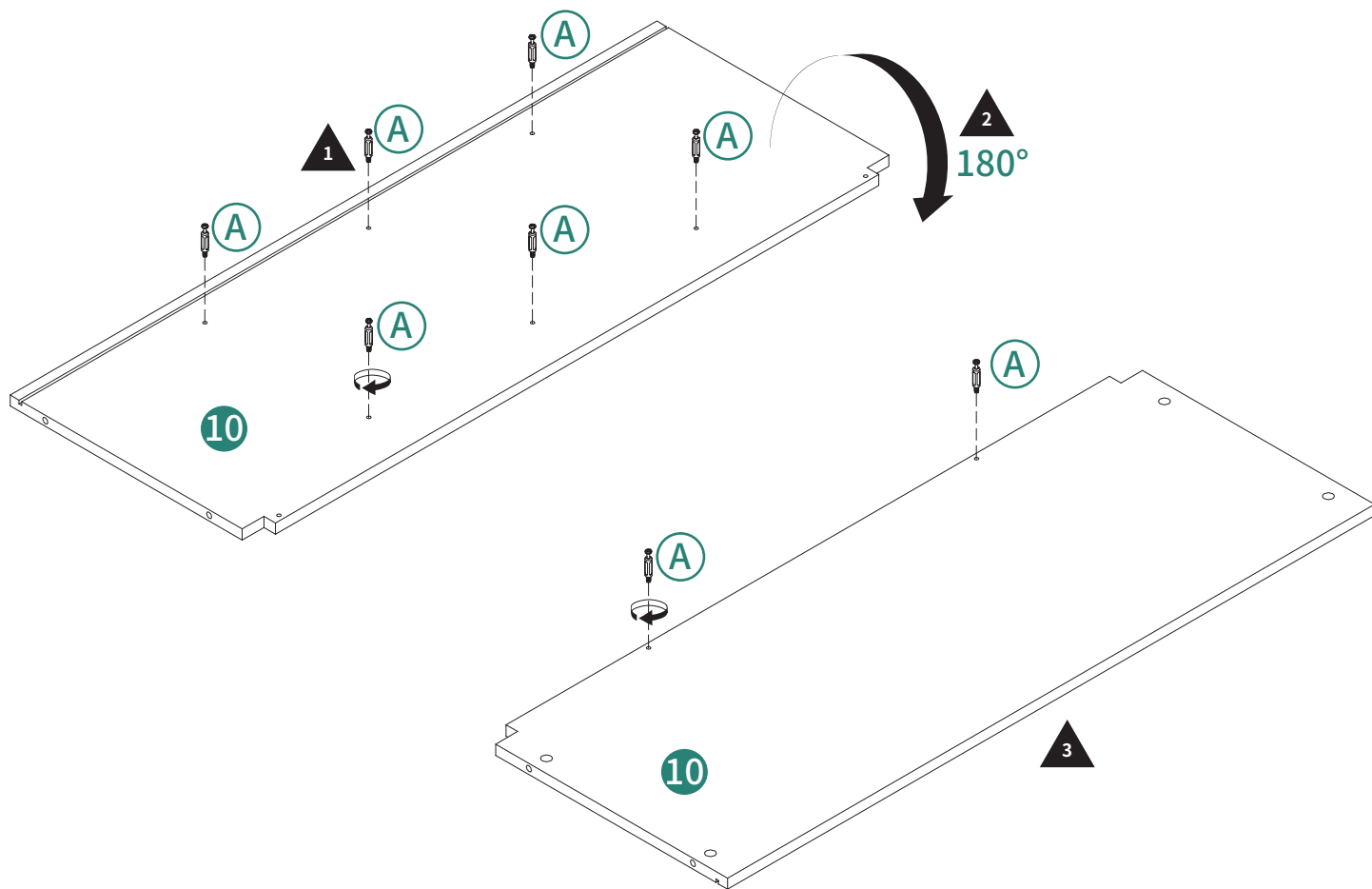
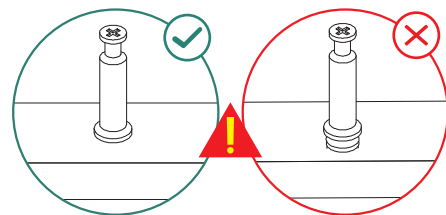
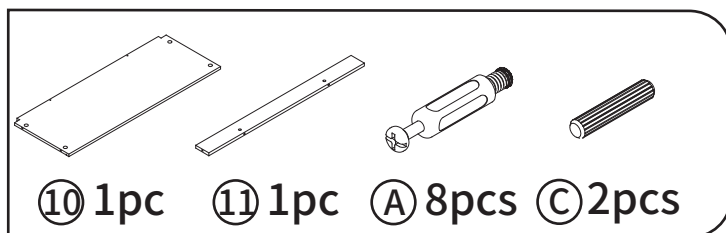

2

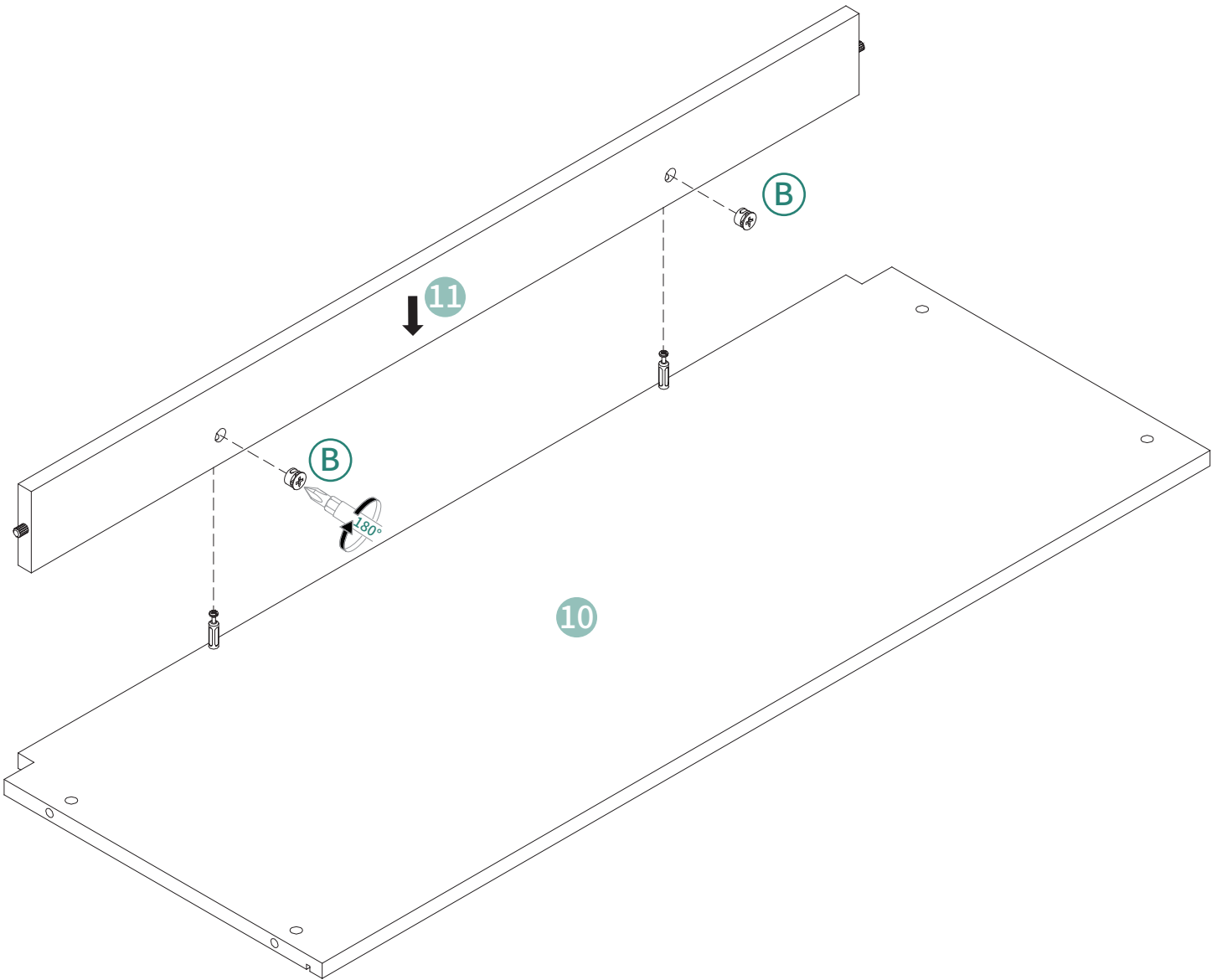
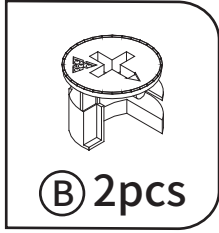

# 3

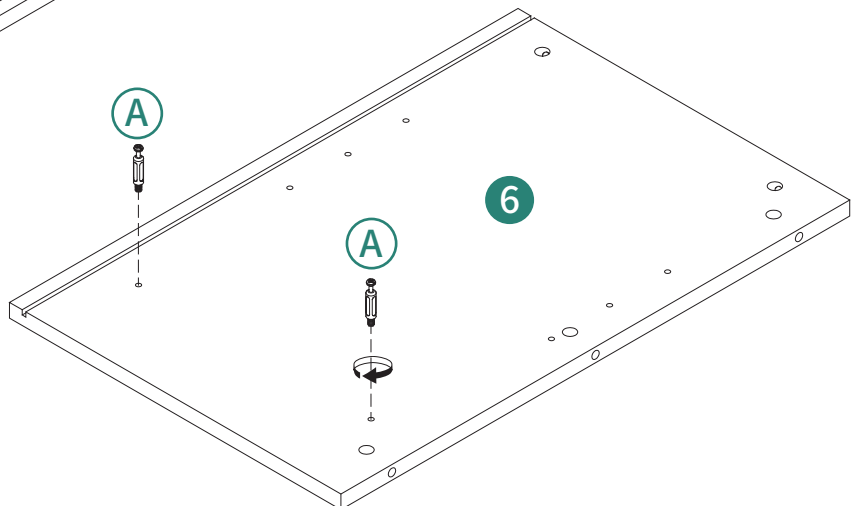
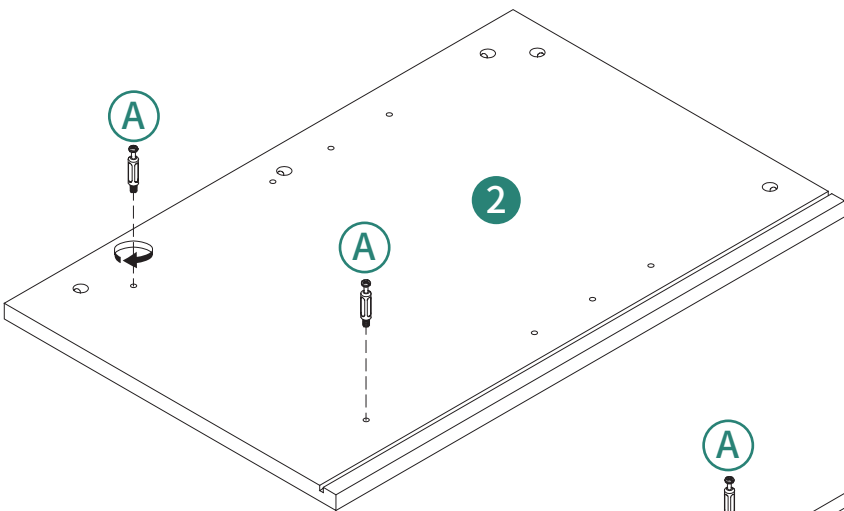
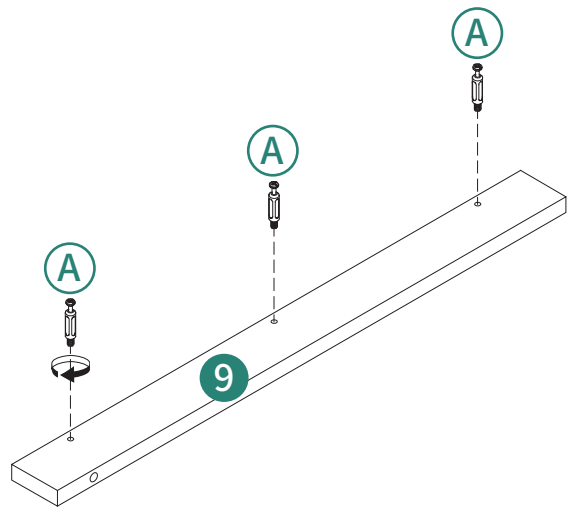
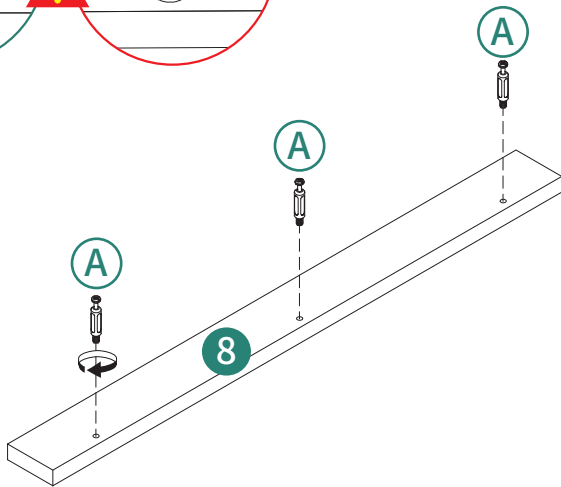
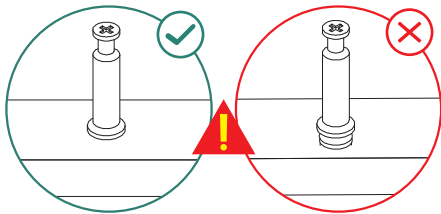
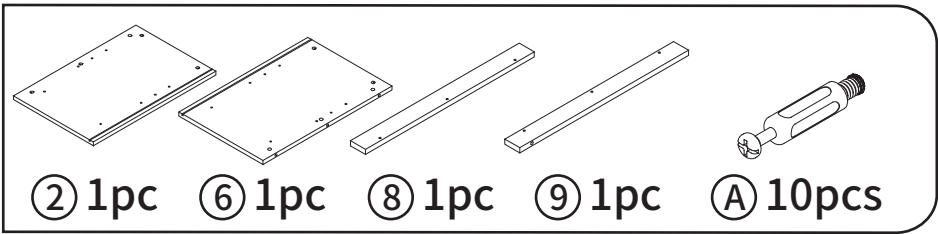

4

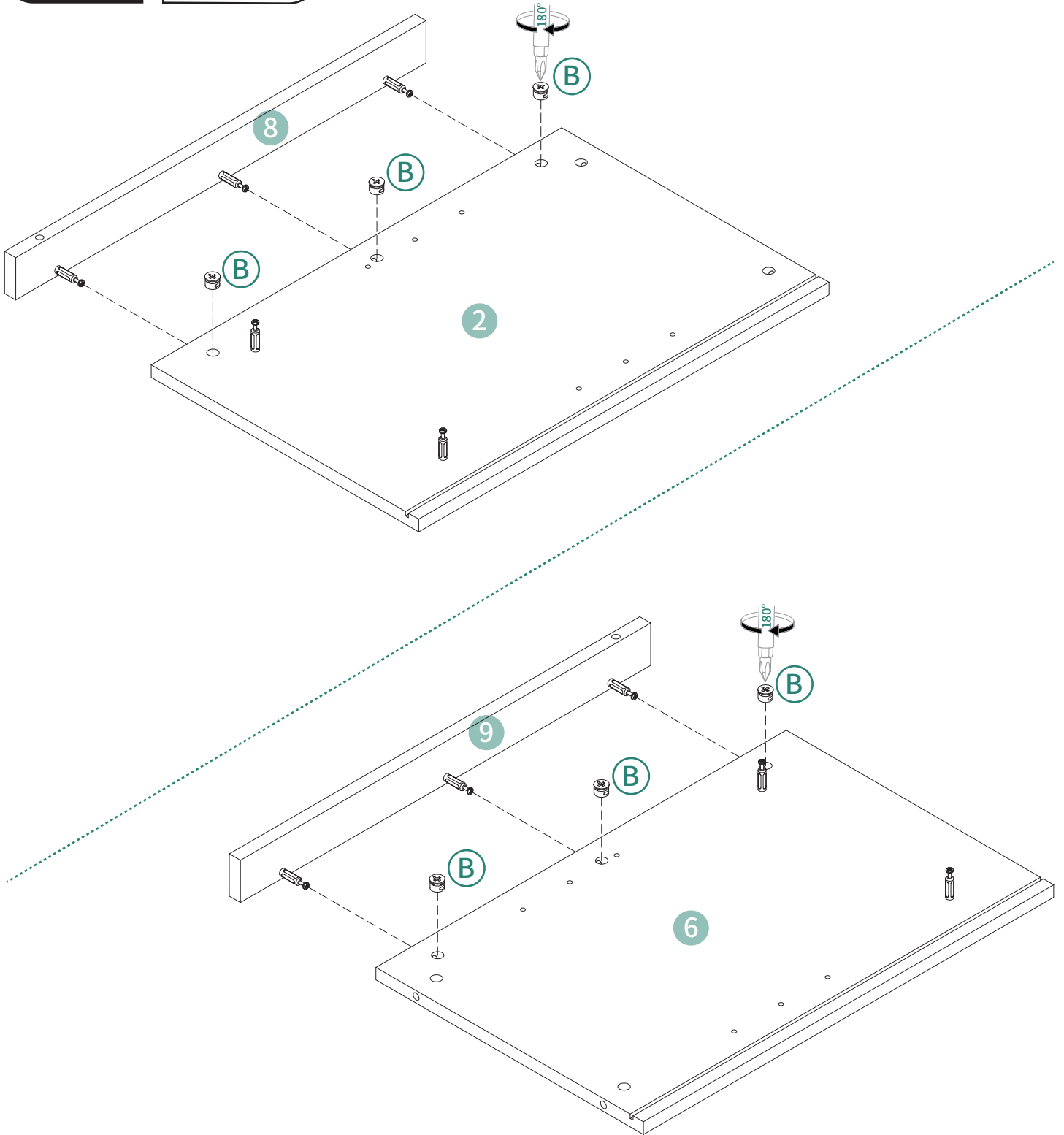
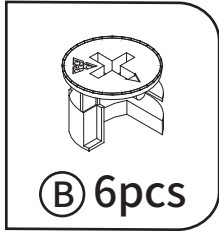

5

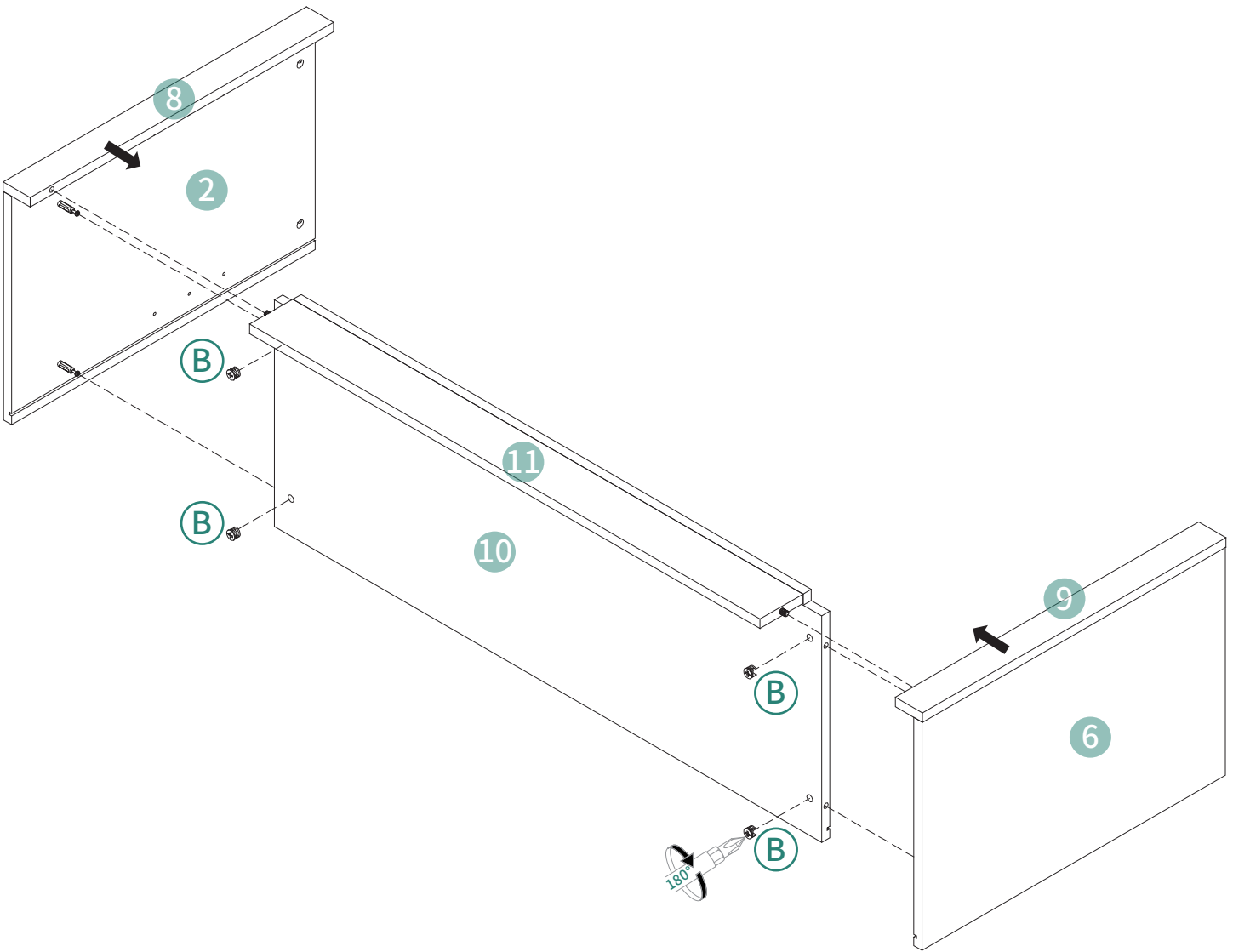
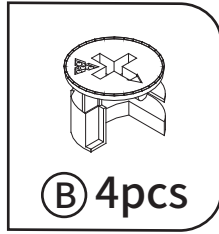

# 6

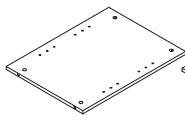

③ 1pc

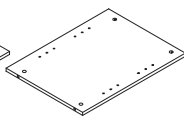

④ 1pc

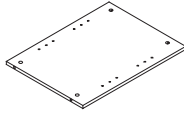

⑤ 1pc

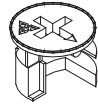

Ⓑ 6pcs

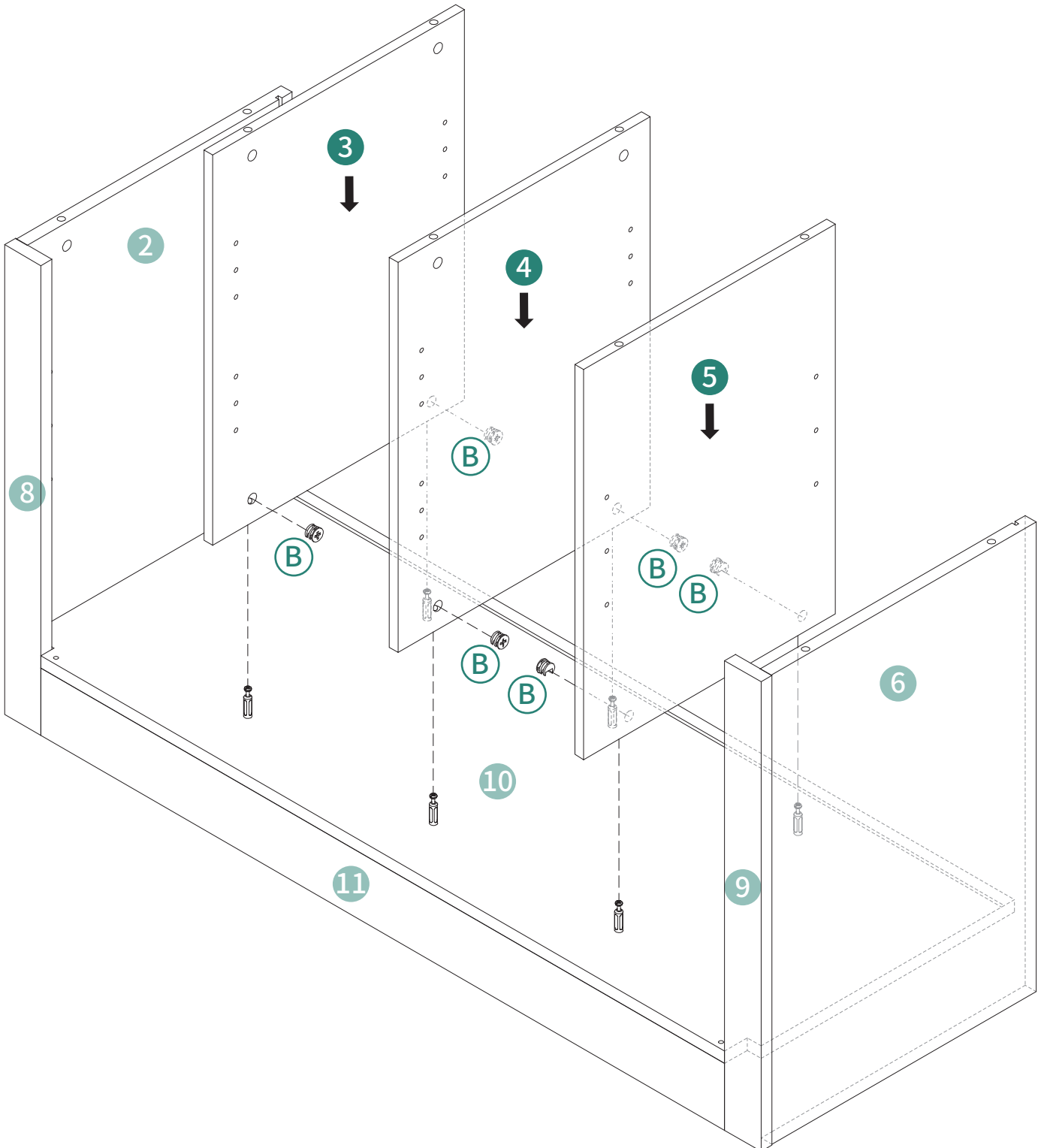

7

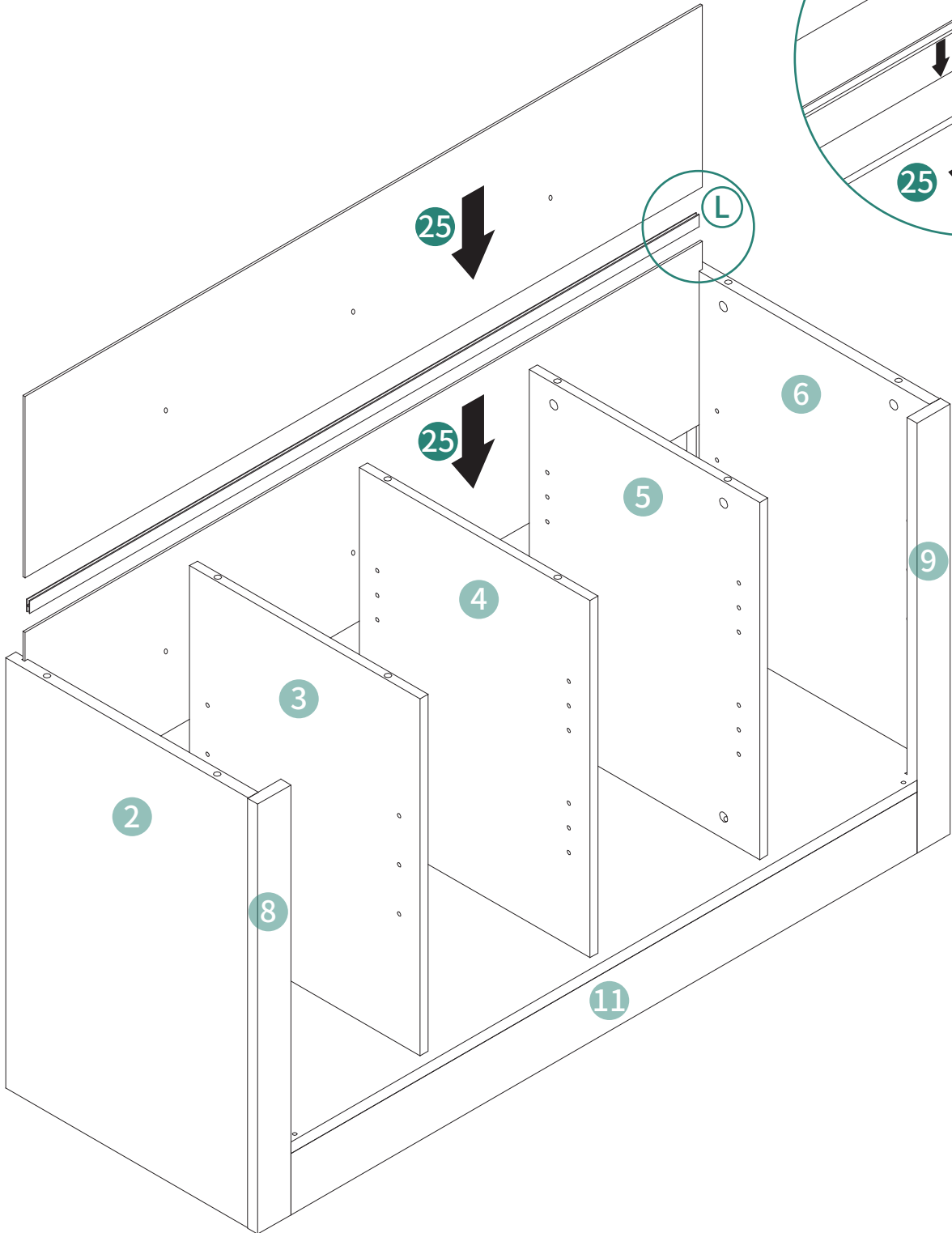
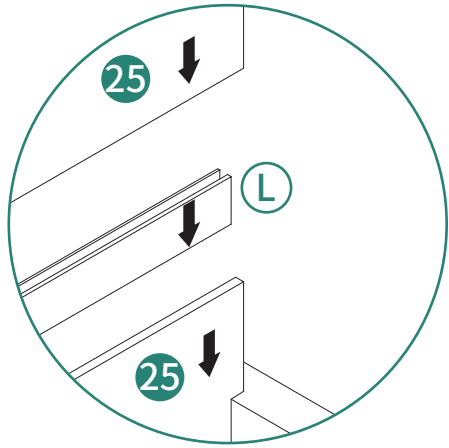
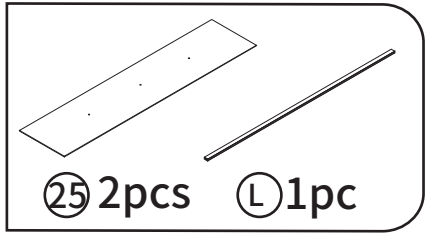

8

ST3\*12mm

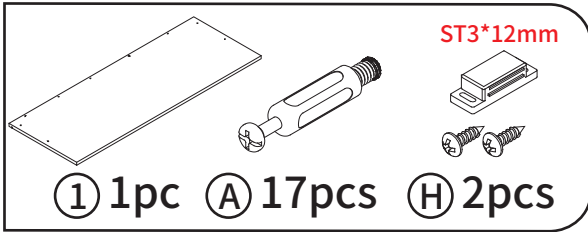

① 1pc ① A 17pcs ① H 2pcs

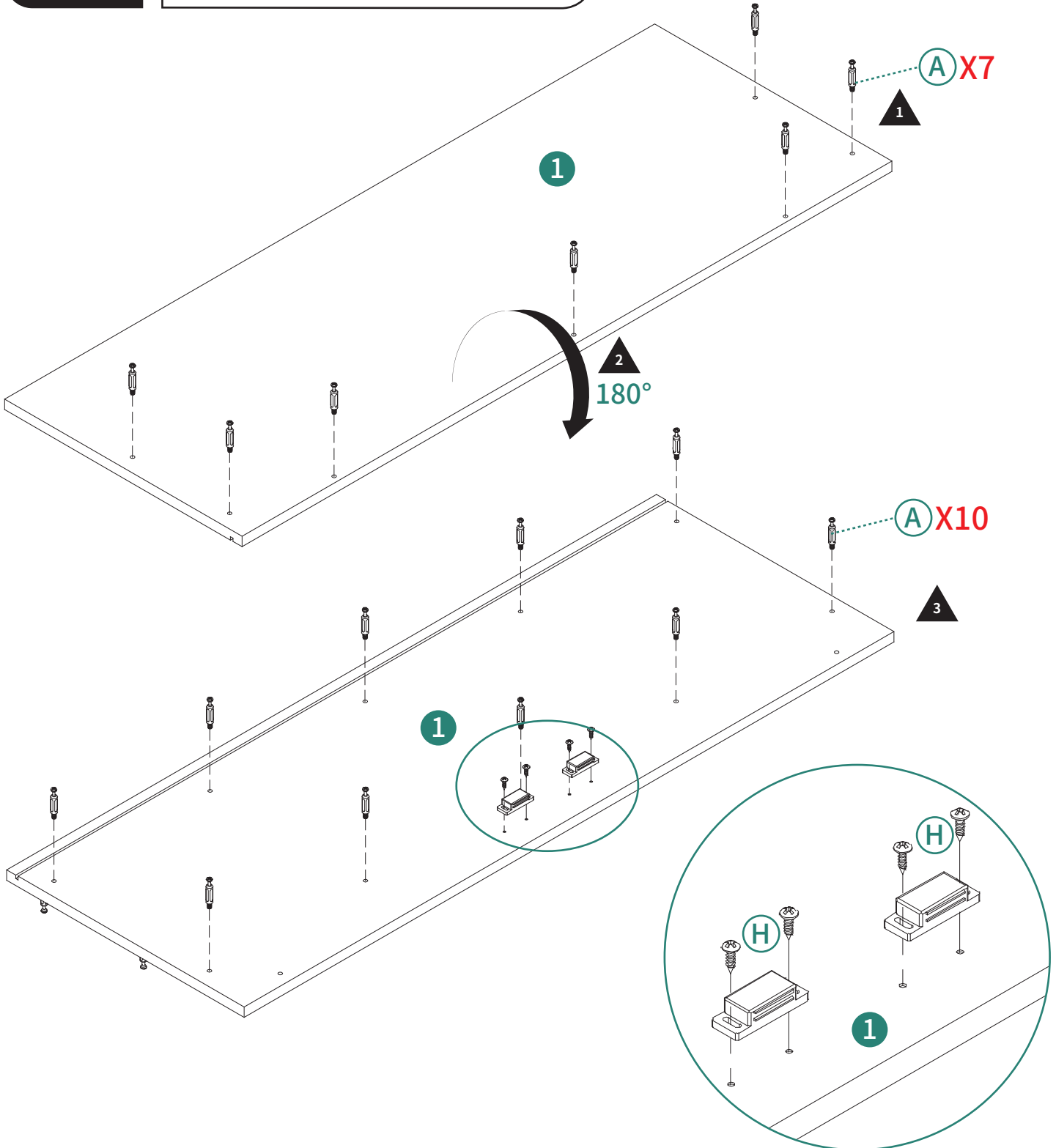
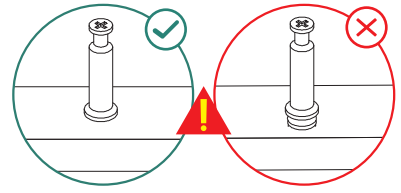

9

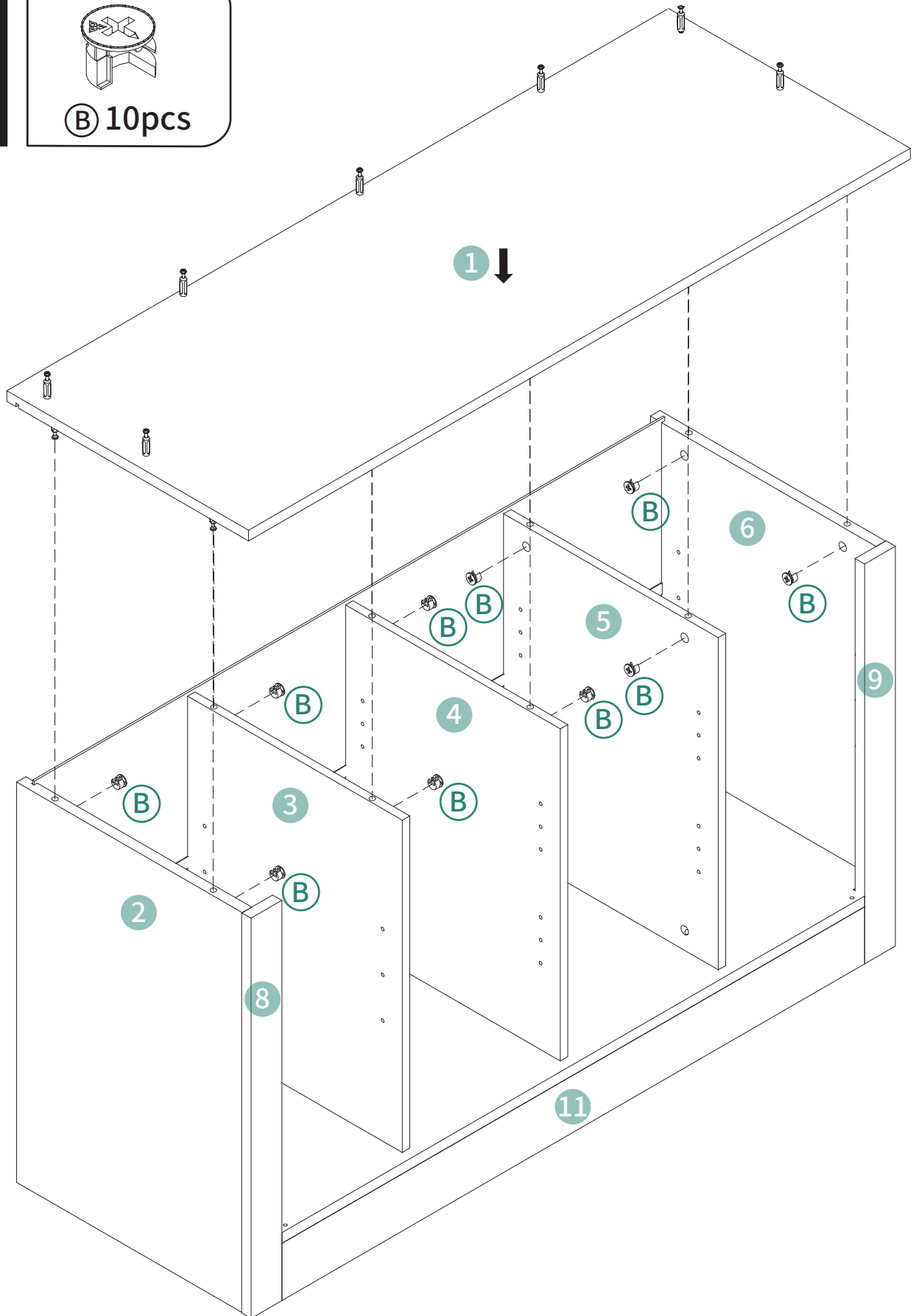
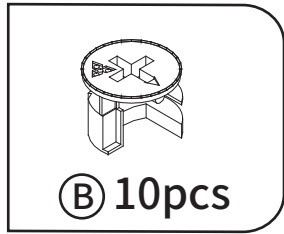

10

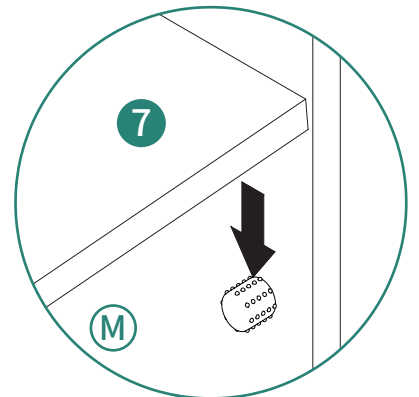
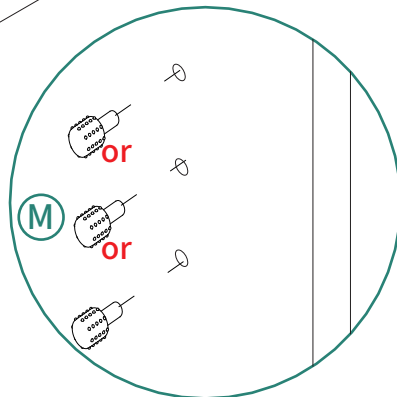
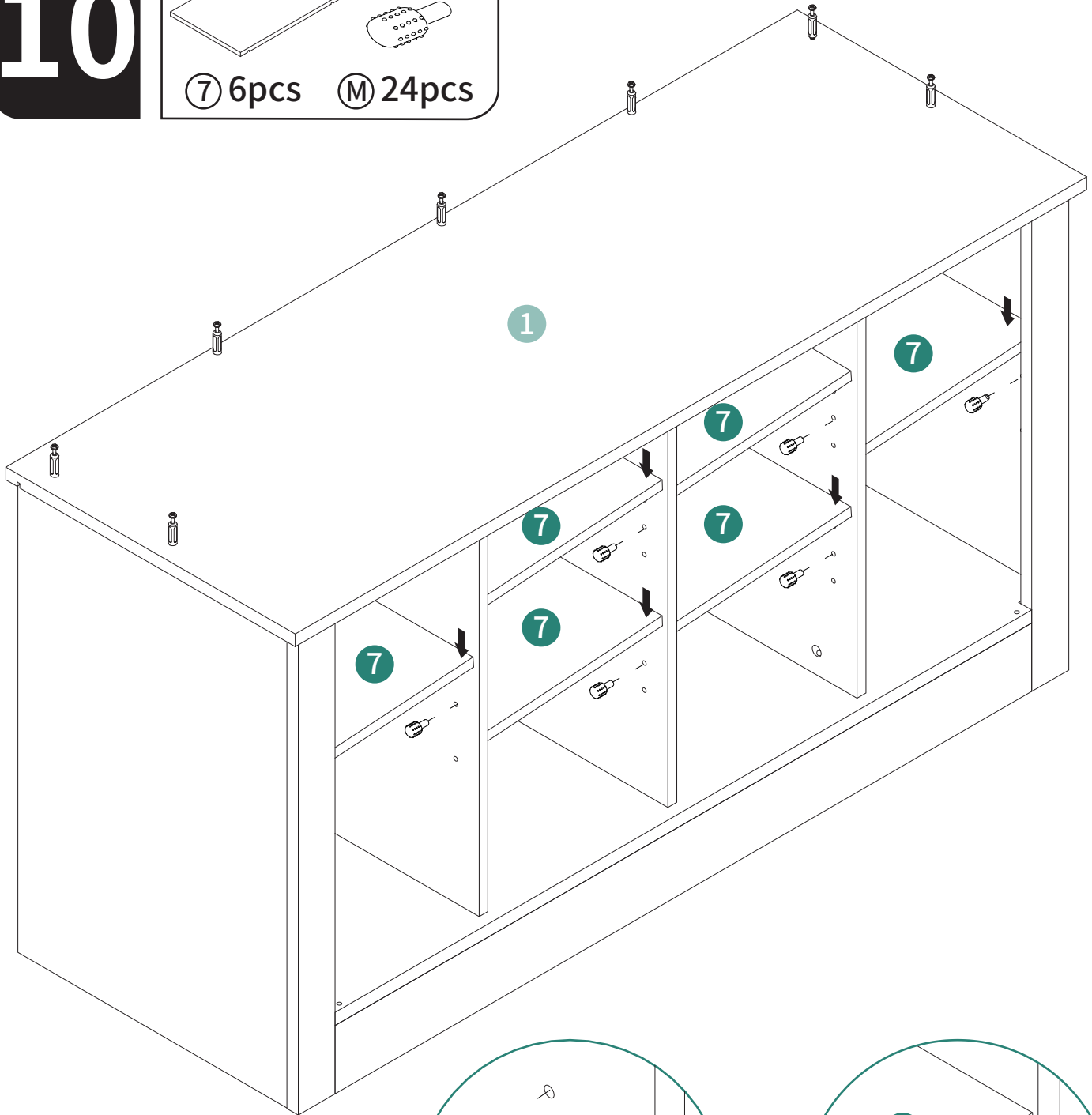
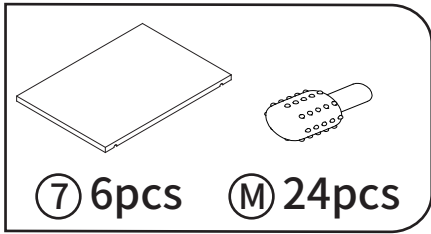

# 11

ST3.5\*14mm

ST3\*12mm

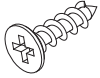

ⓓ 6pcs

ⓙ 6pcs

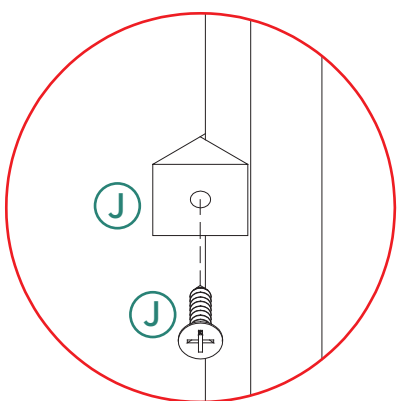
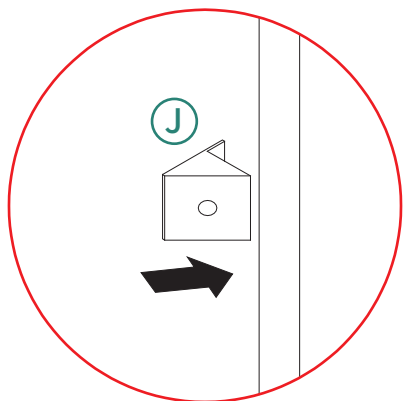
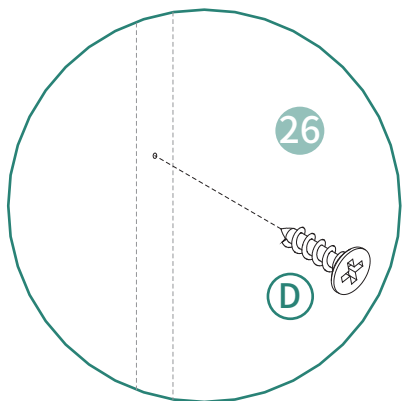
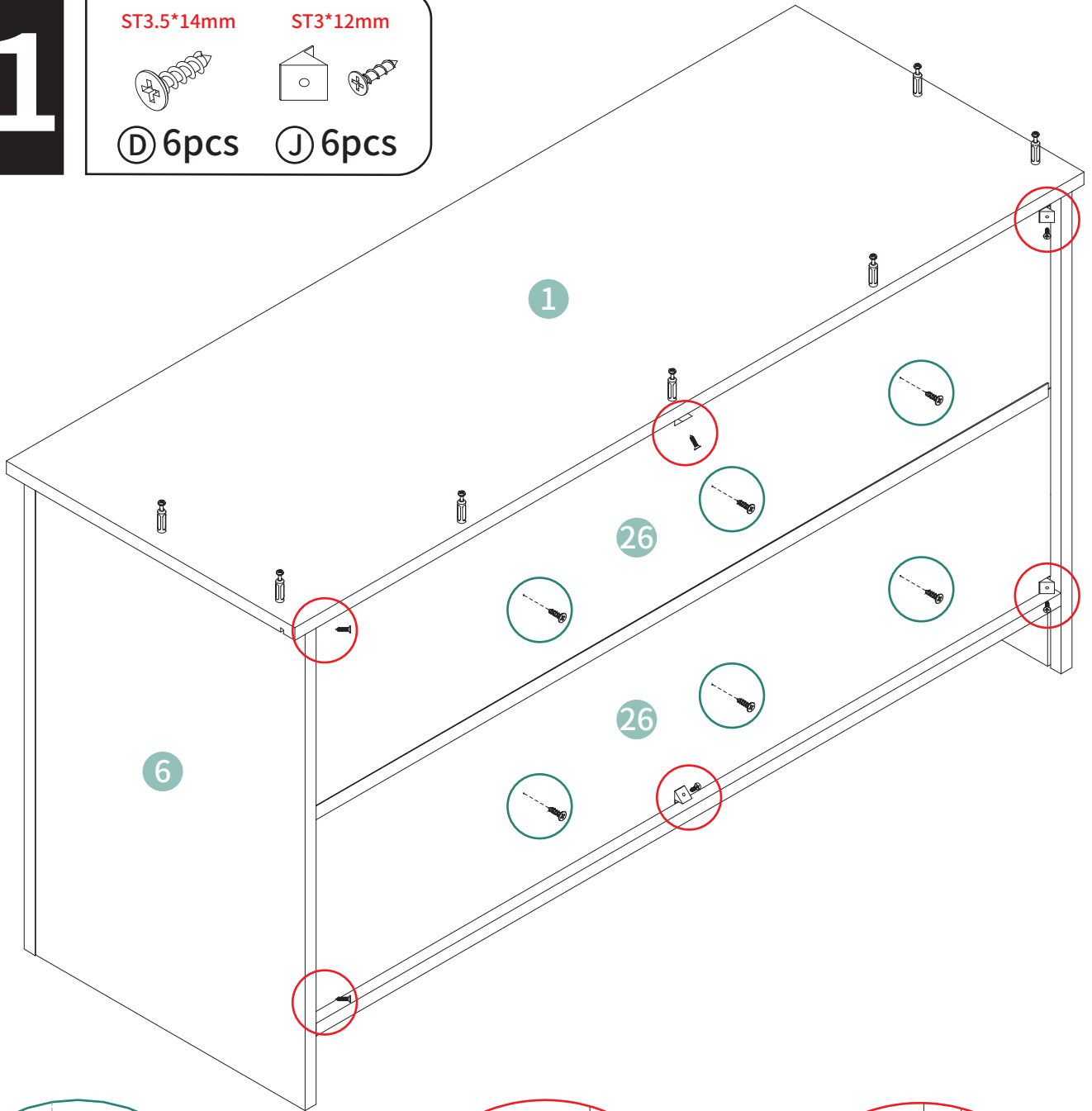

# 12

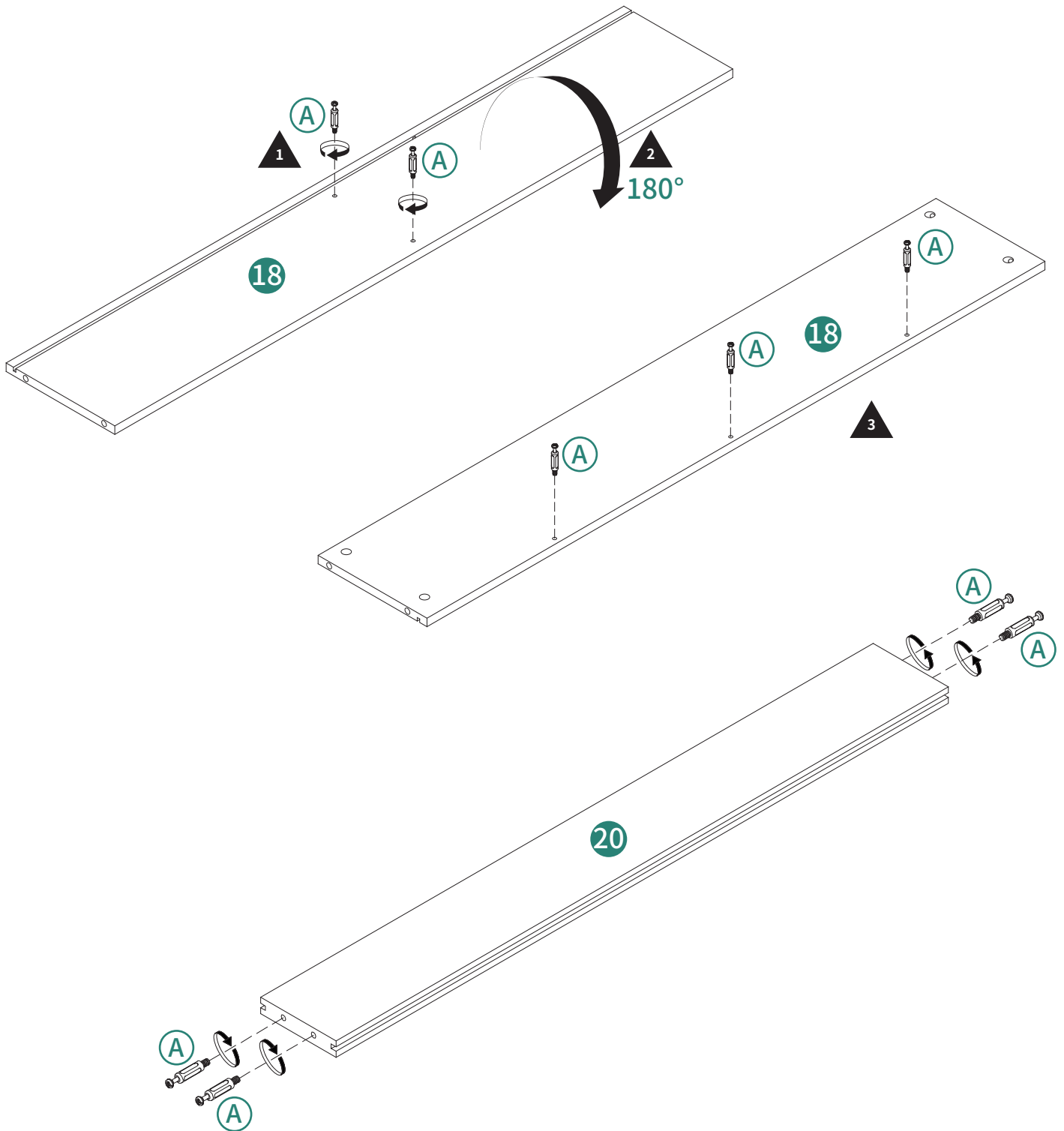
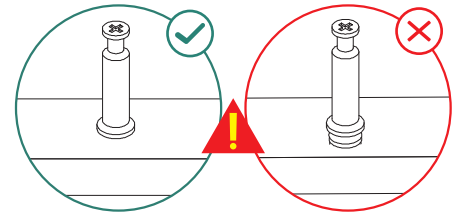
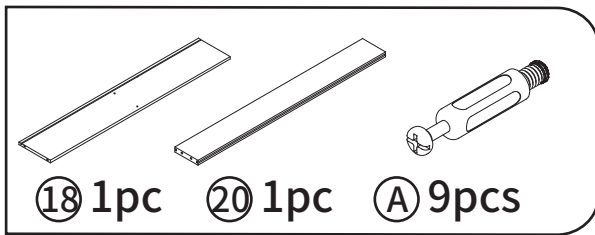

# 13

⑭ 1pc      ⑳ 1pc      Ⓐ 18pcs

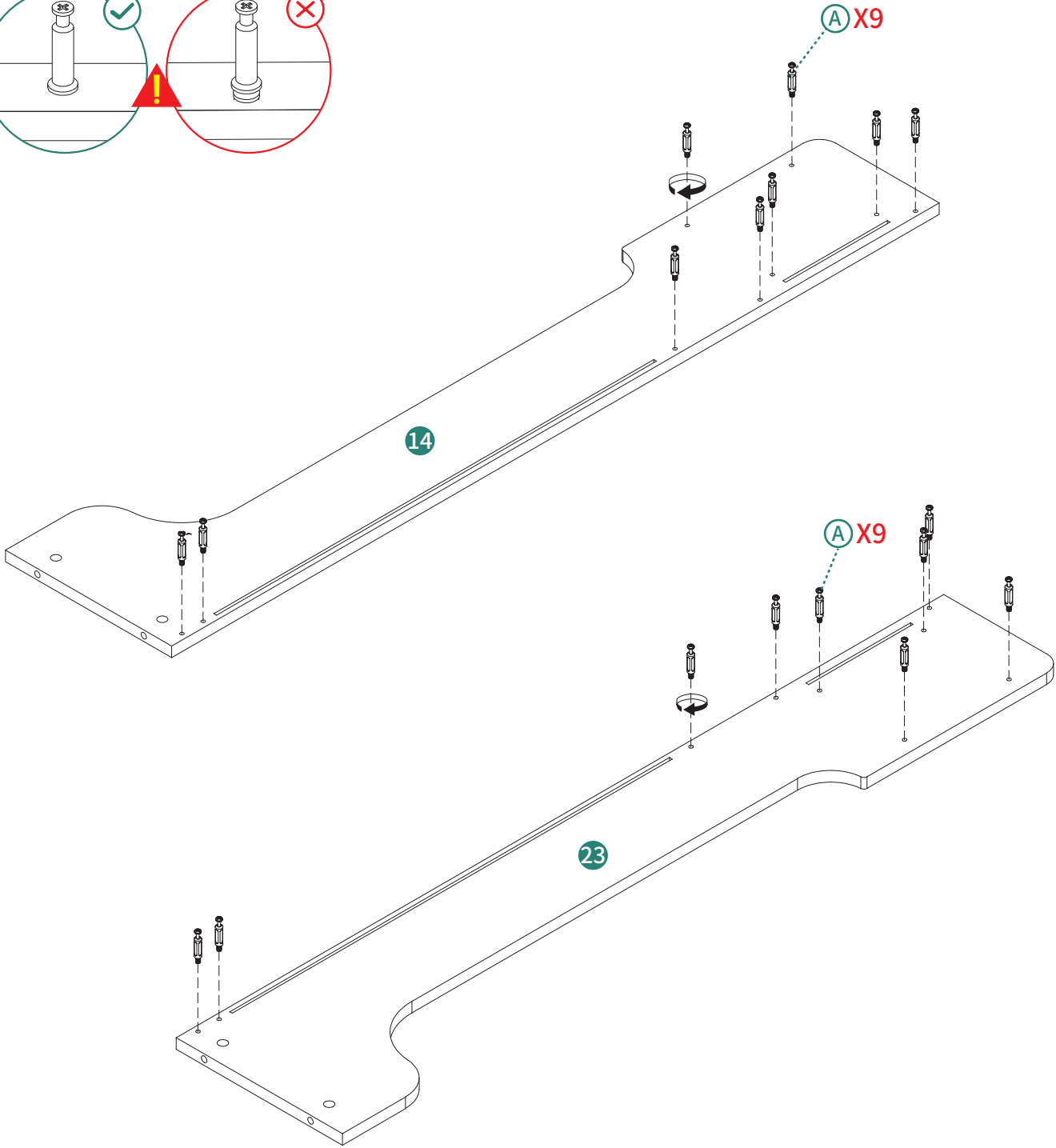
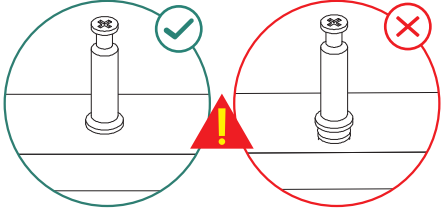
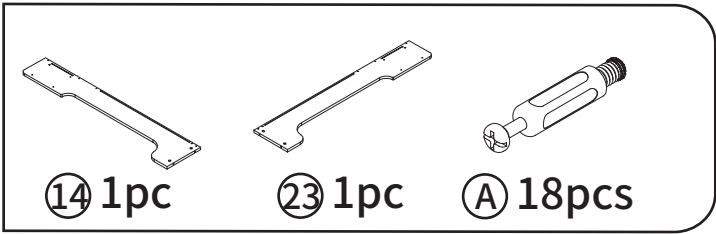

# 14

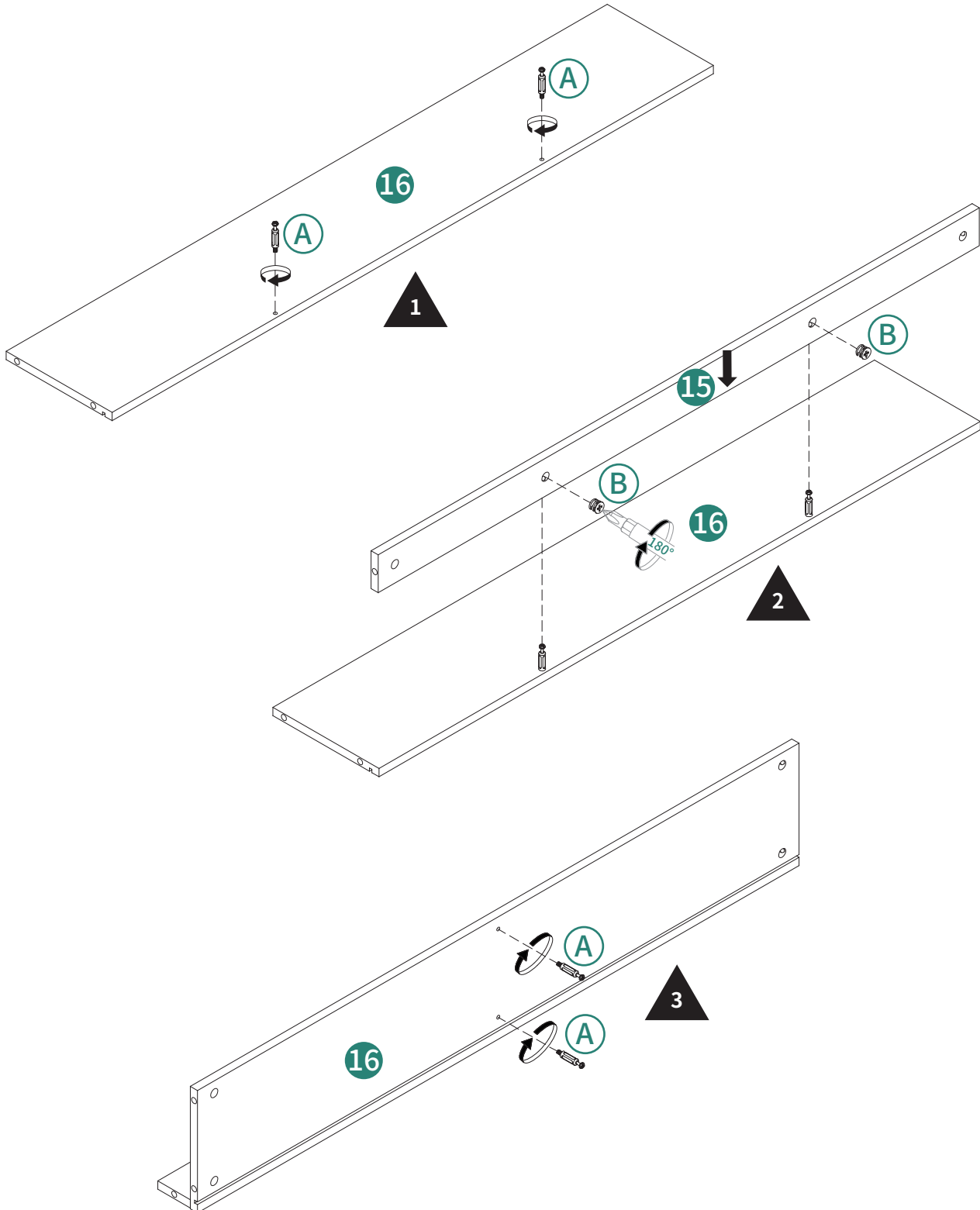
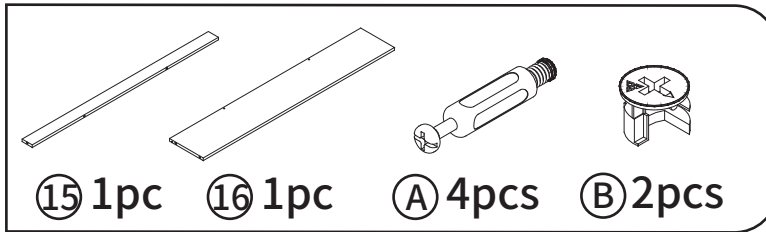

# 15

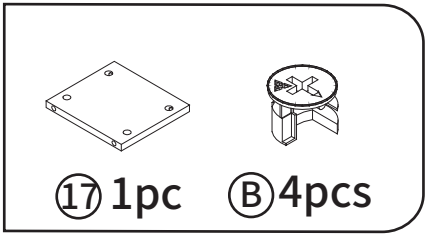

①⑦ 1pc    Ⓑ 4pcs

This block contains two small diagrams: a square plate with four holes (part 17) and a circular component with four protrusions (part B).

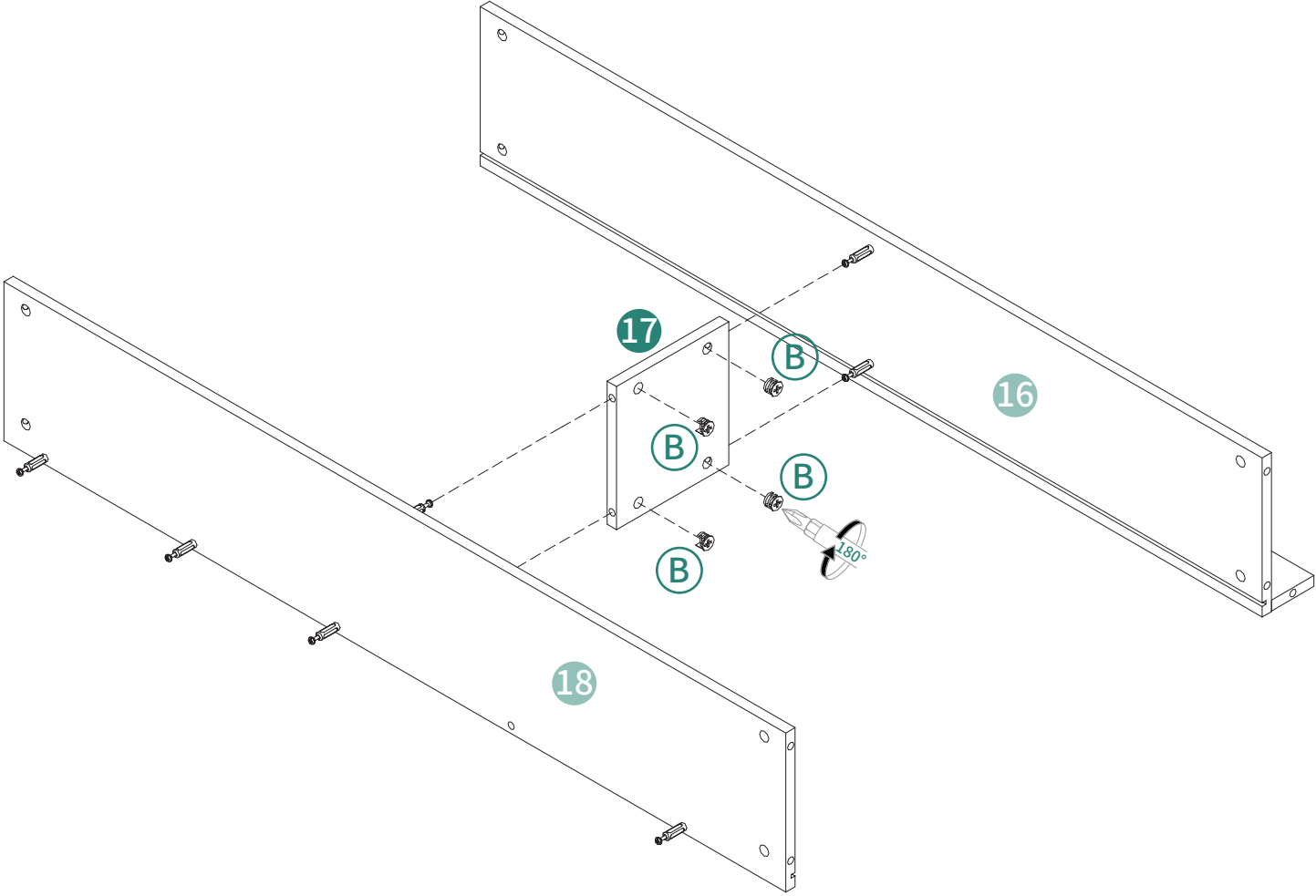

# 16

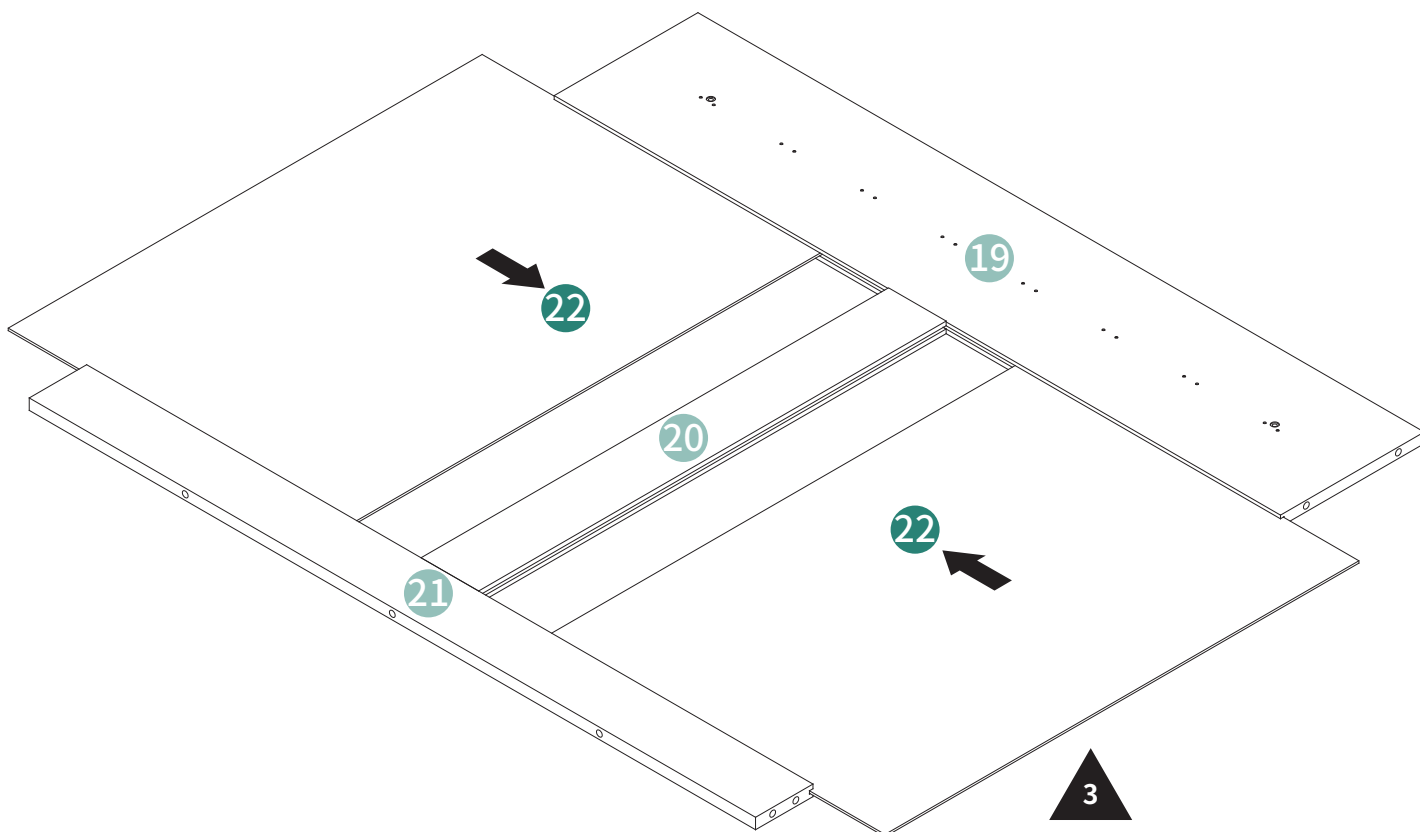
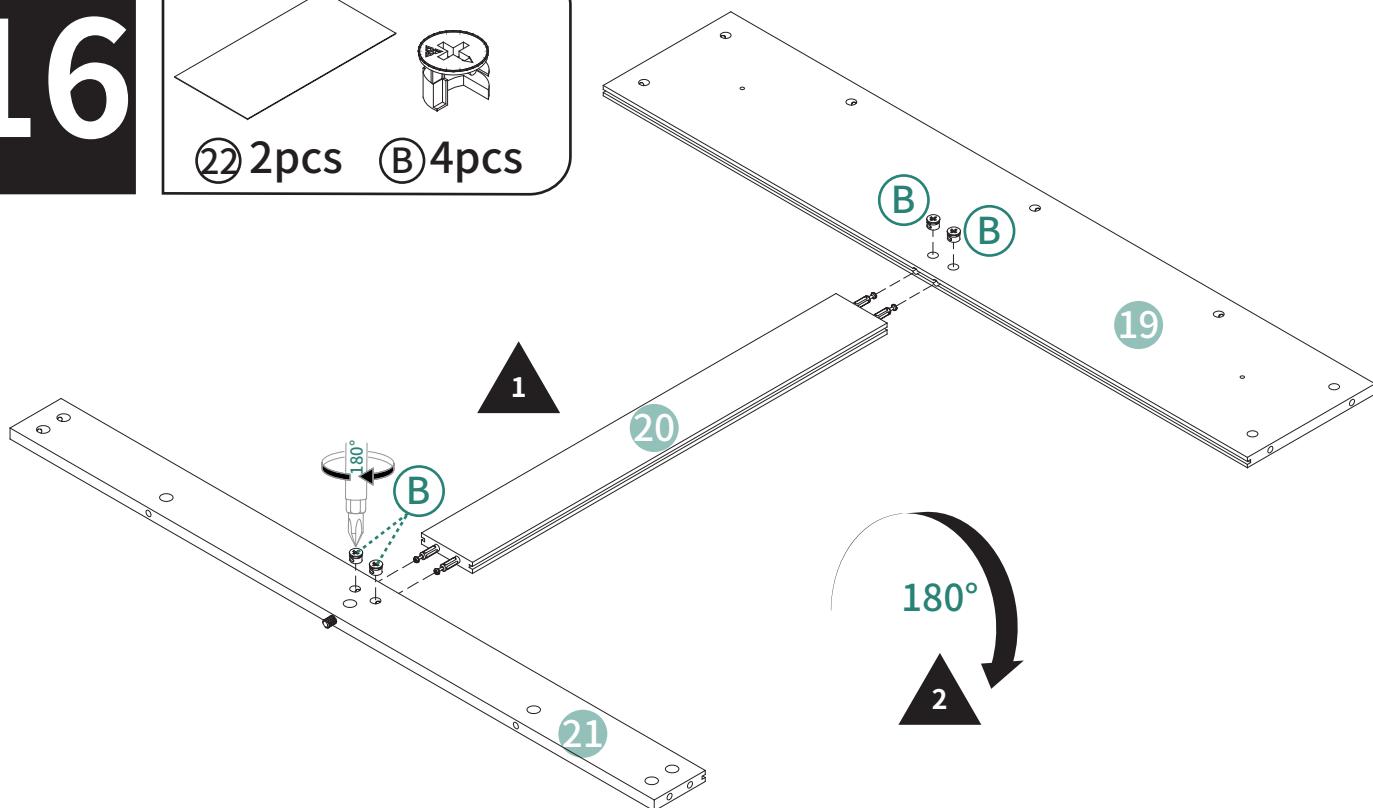
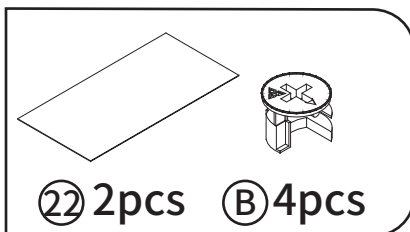

23

**17**

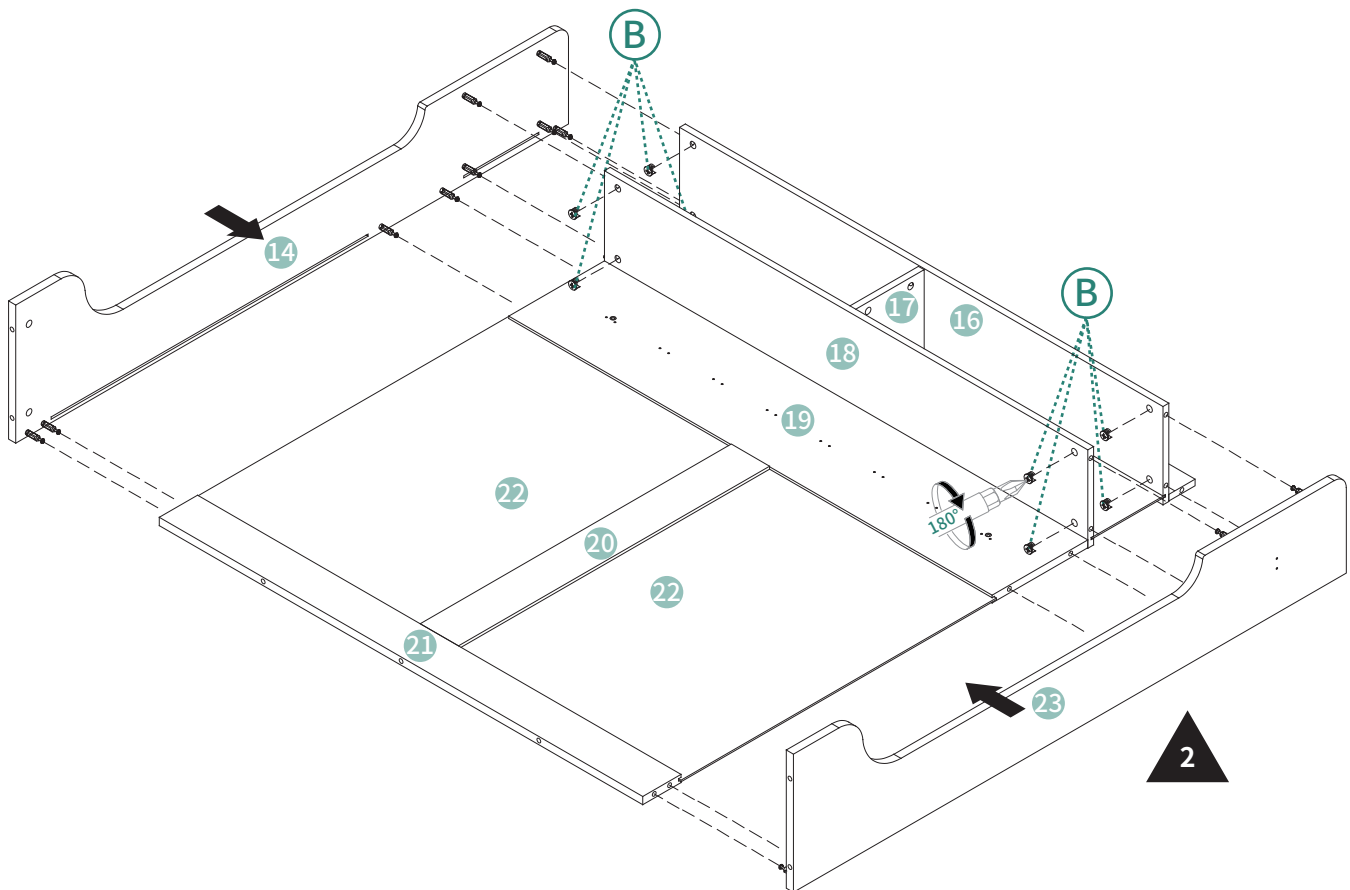
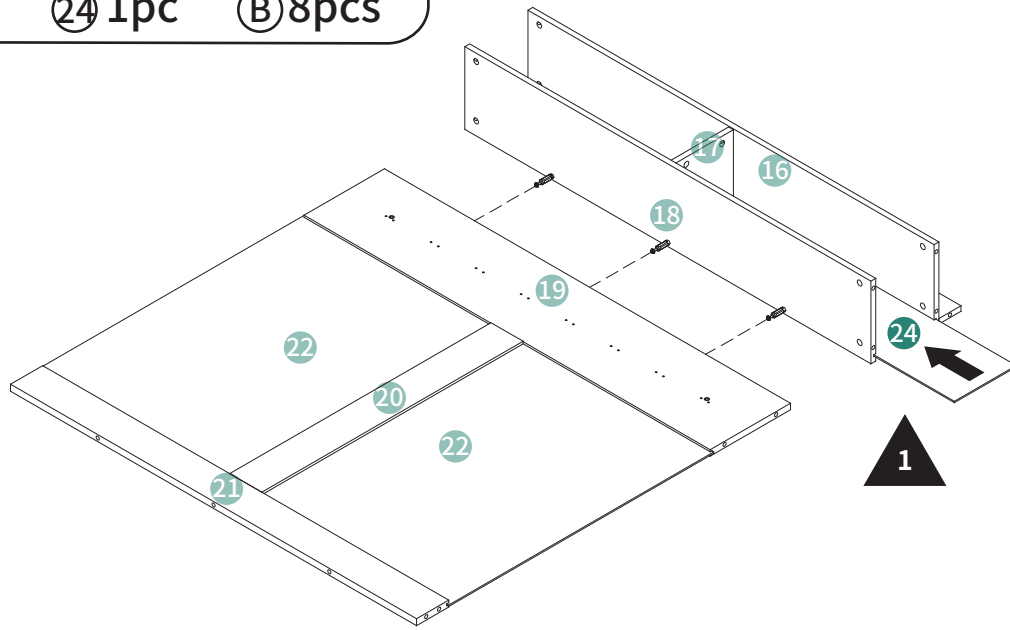
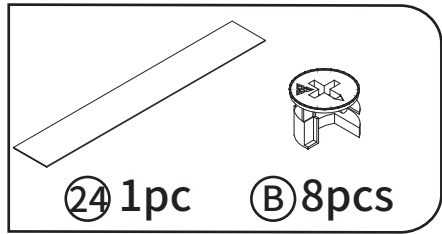

24

# 18



ⓑ 13pcs

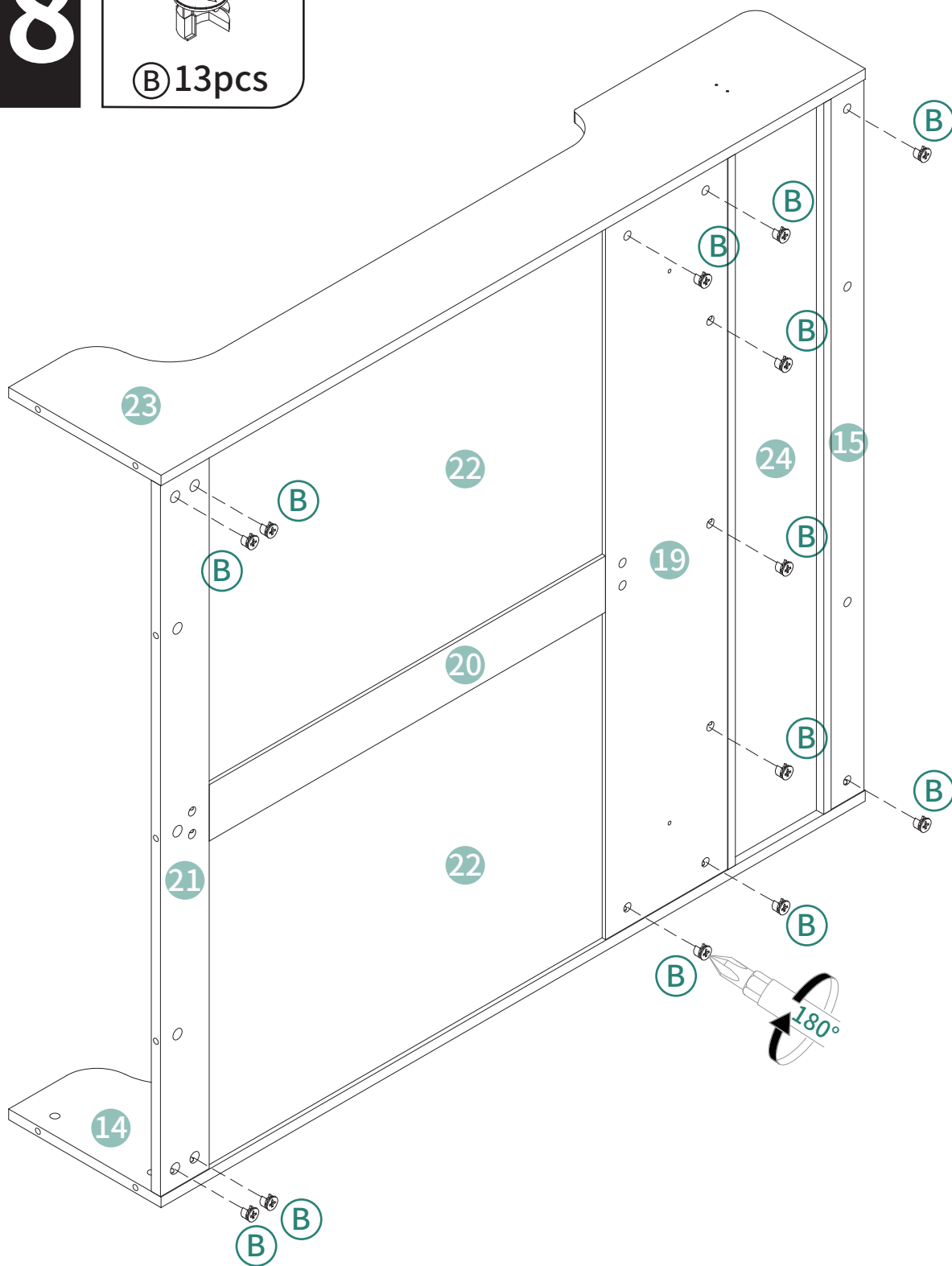

# 19



Ⓑ 7pcs



Ⓘ 66pcs

In order to make the product more beautiful, please paste hardware J on the exposed holes

Um das Produkt schöner zu gestalten, bitte Hardware J auf das freiliegende Loch kleben.

Pour rendre le produit plus beau, veuillez coller la pièce J sur le trou exposé.

Per rendere il prodotto più bello, si prega di incollare l'hardware J sul foro esposto.

Para hacer que el producto sea más hermoso, por favor pegue el hardware J en el agujero expuesto.

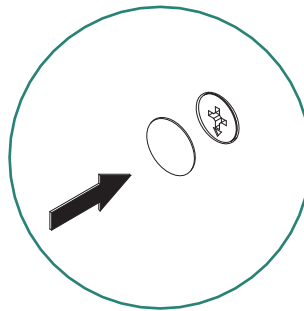

2

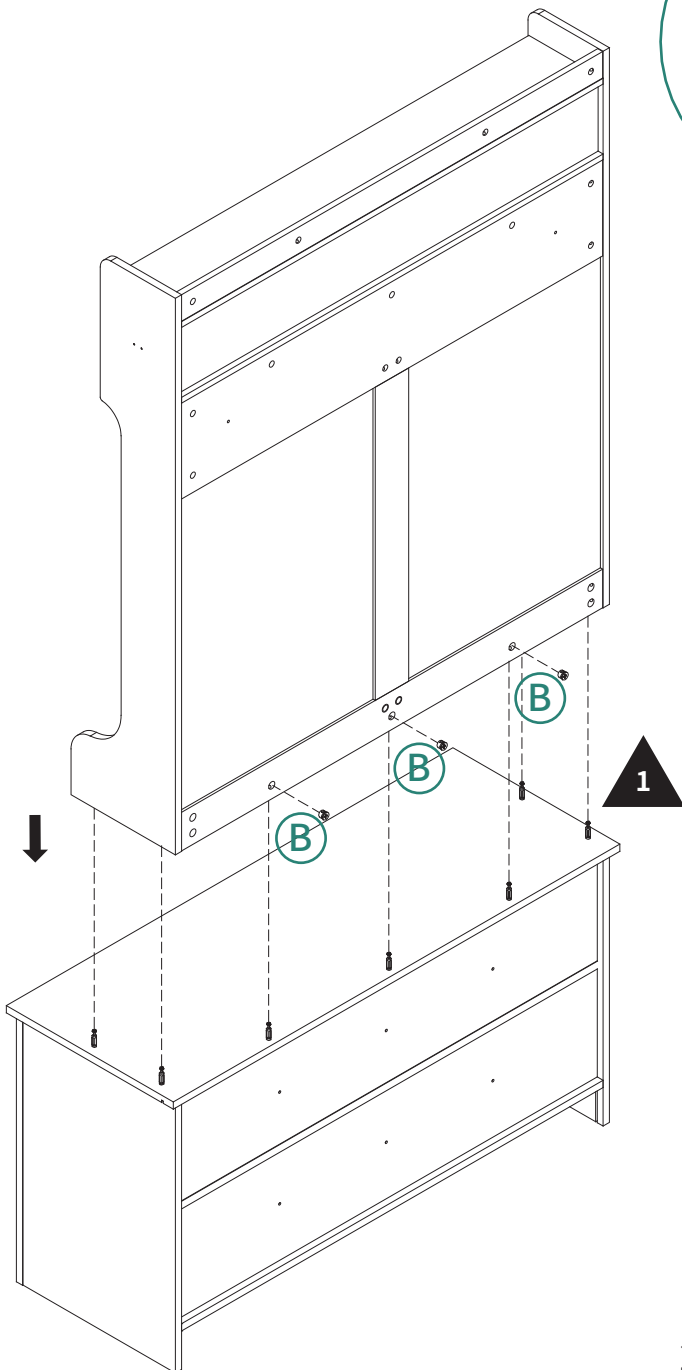

1

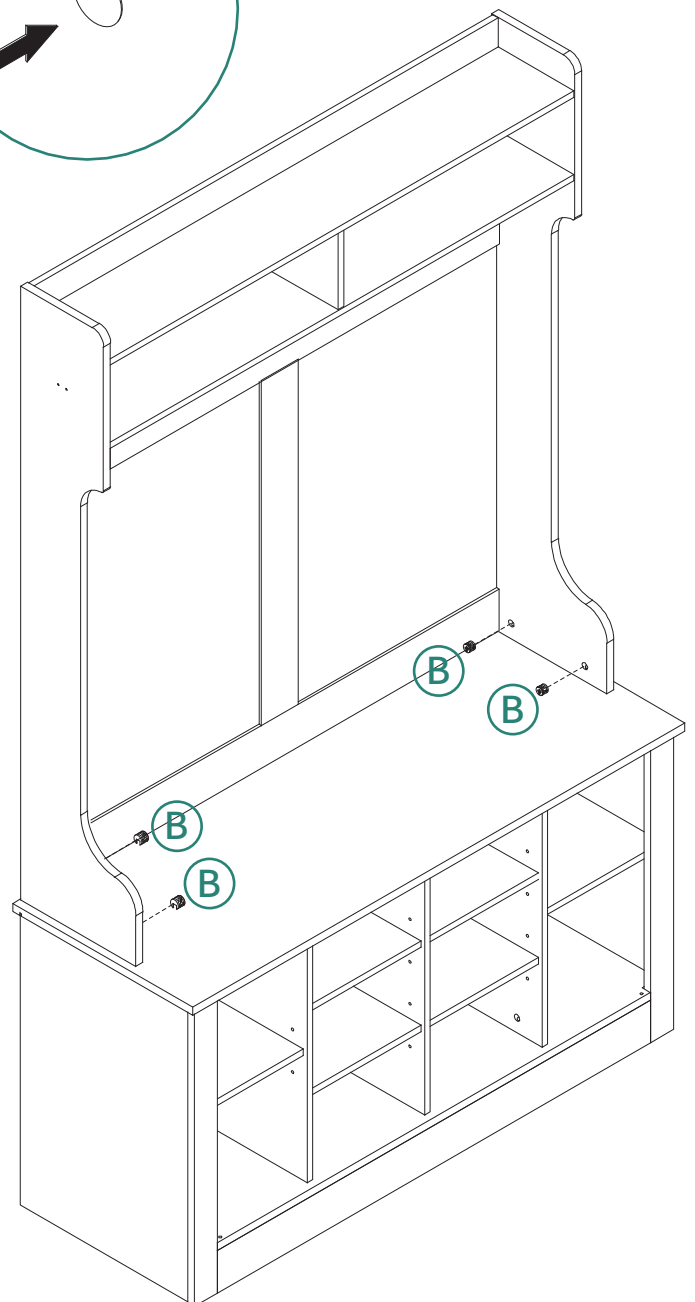

# 20

M4\*18mm

ST3\*10mm

⑫ 1pc   ⑬ 1pc   ④ E 2pcs   ④ G 4pcs   ④ H 2pcs

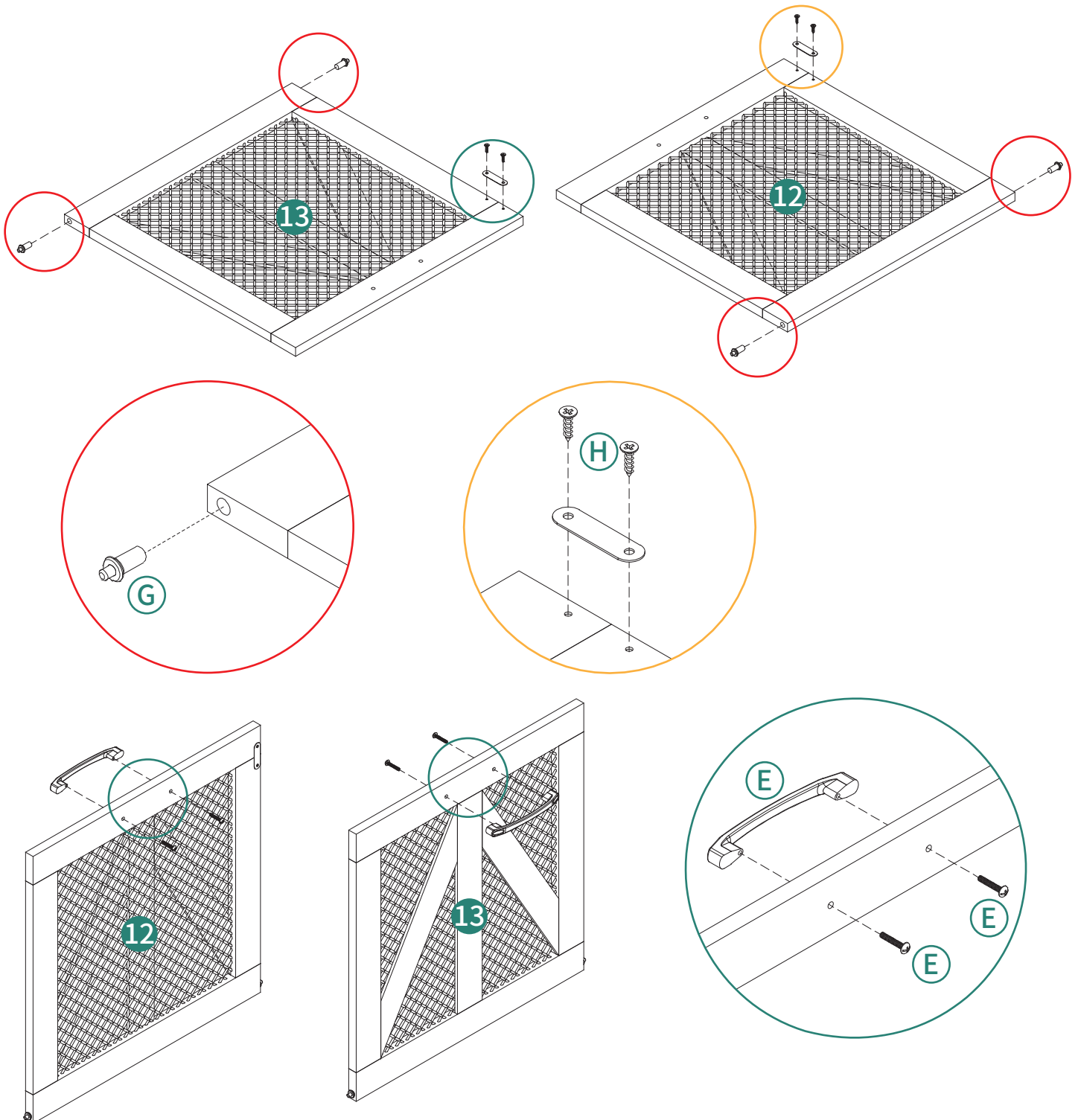

# 21

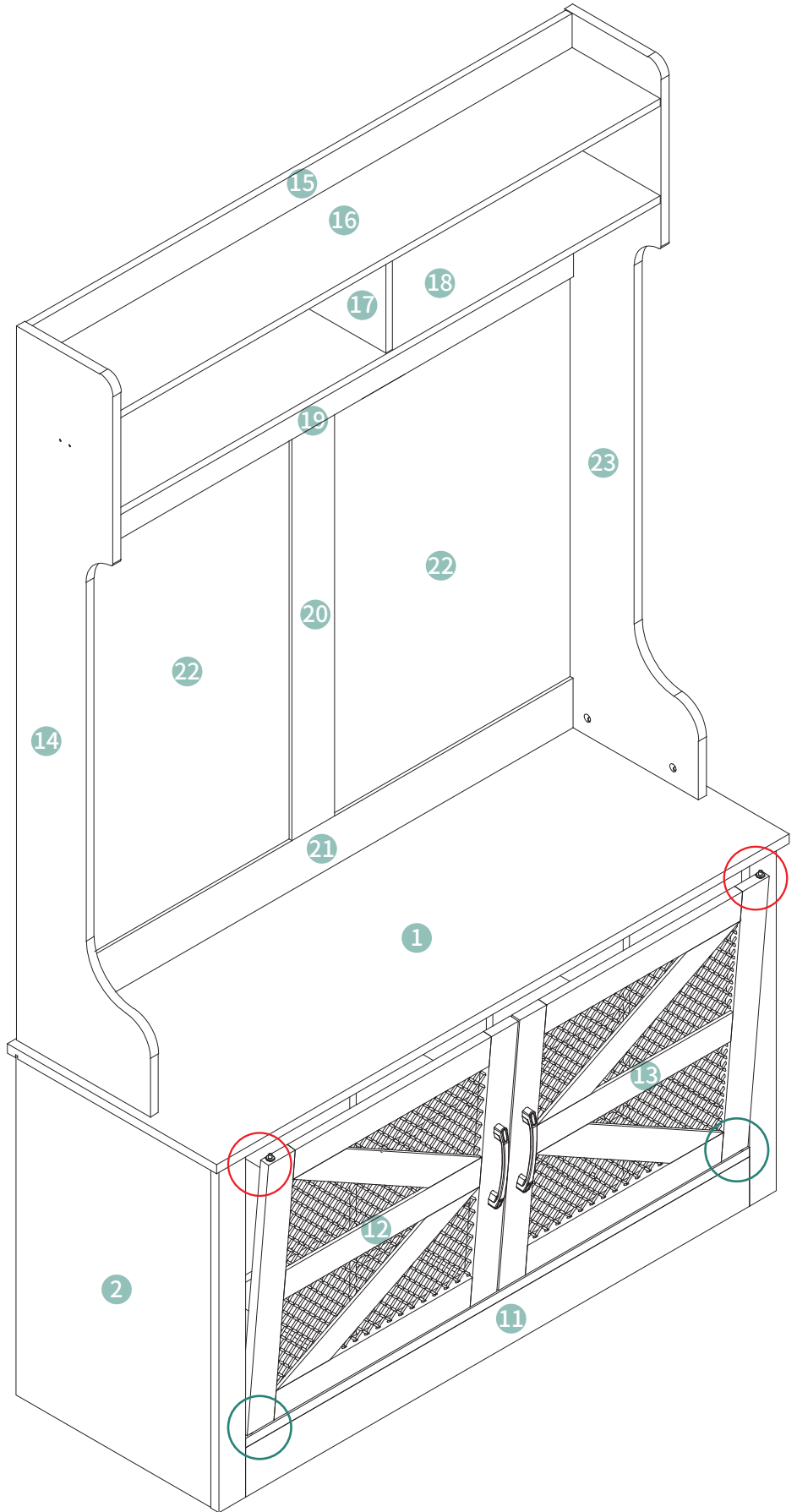
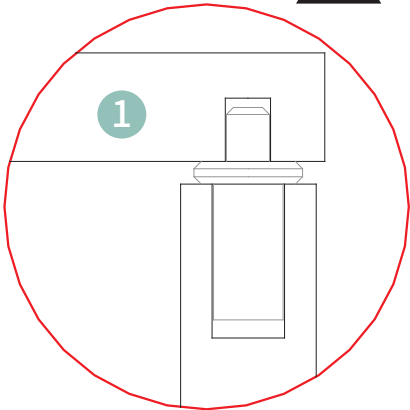
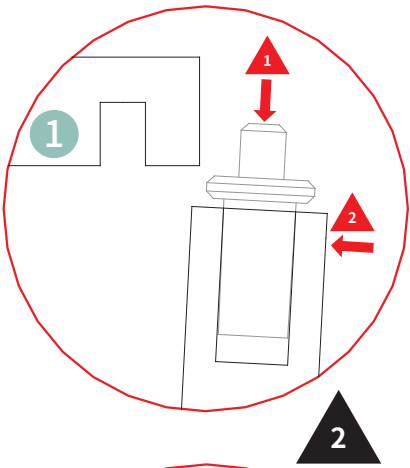
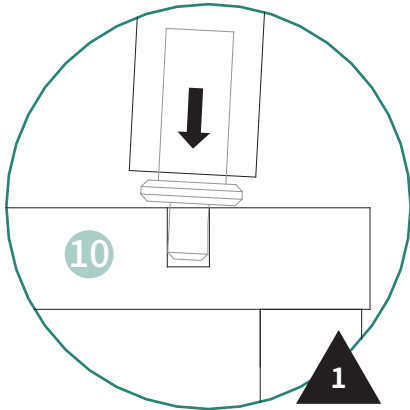

# 22

ST4\*40mm

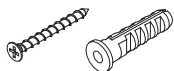

(K) 2pcs

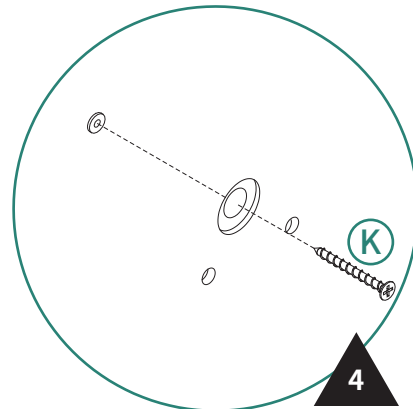
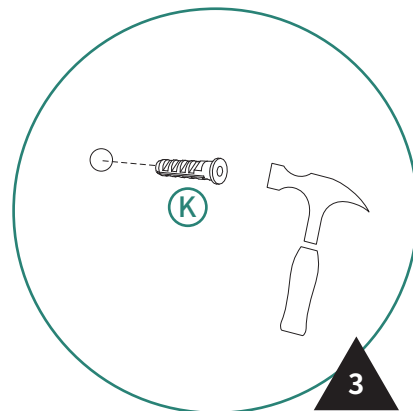
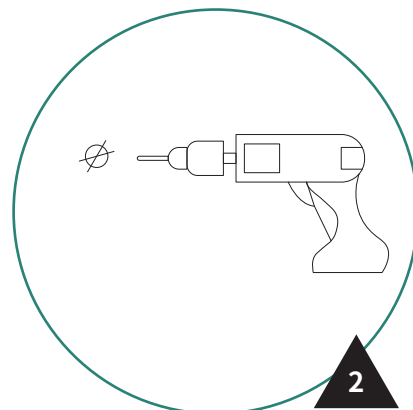
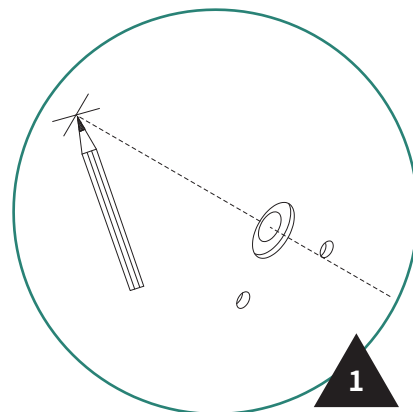
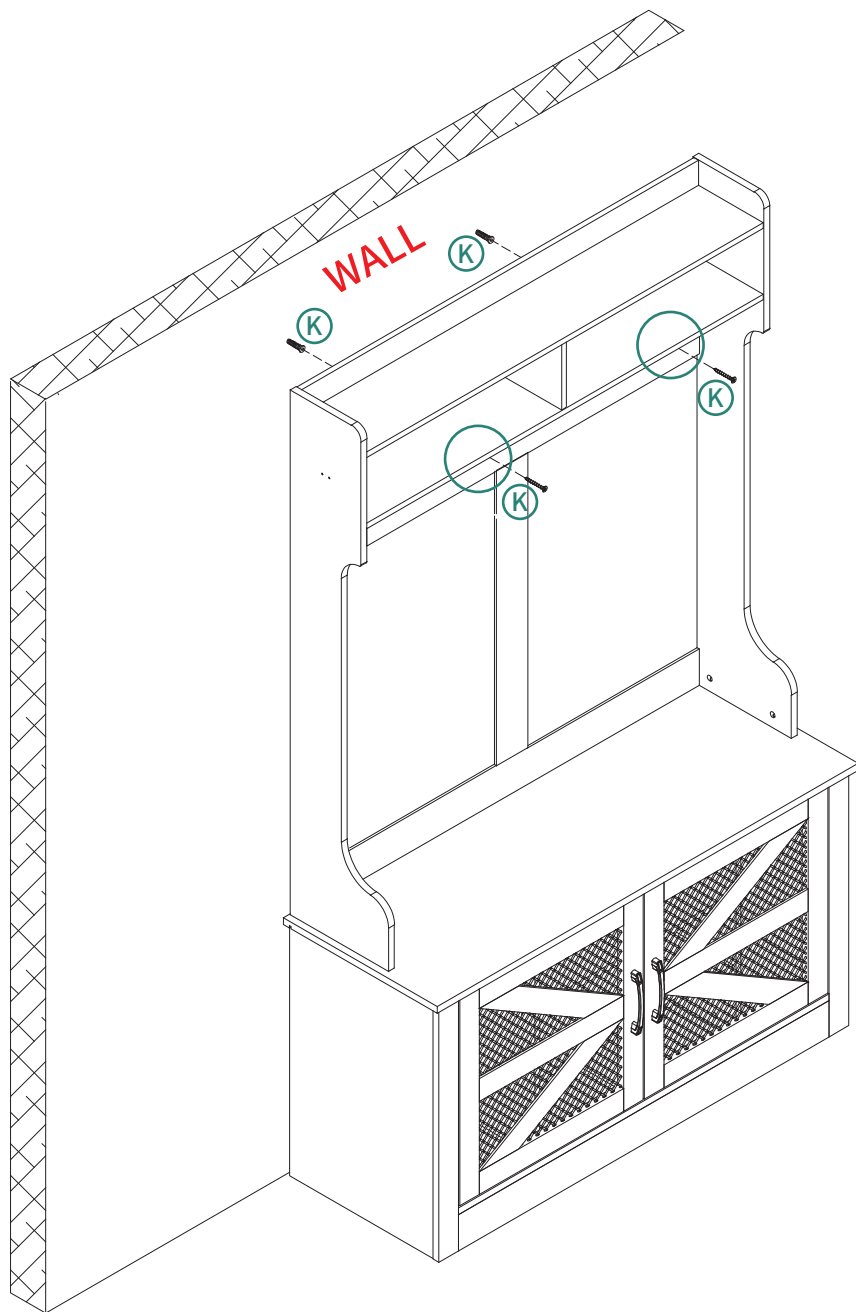

# 23

ST3.5\*14mm

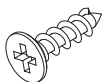

ⓓ 20pcs ⓕ 10pcs

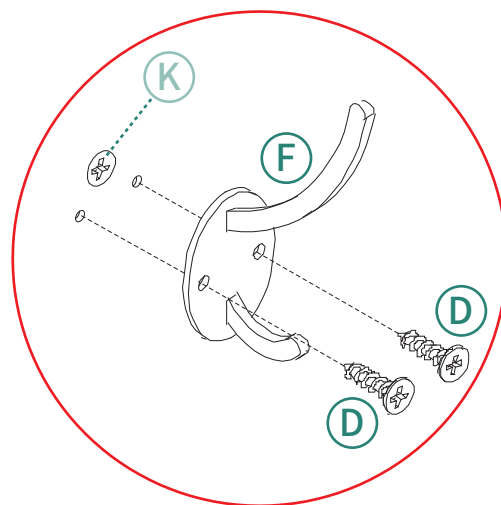
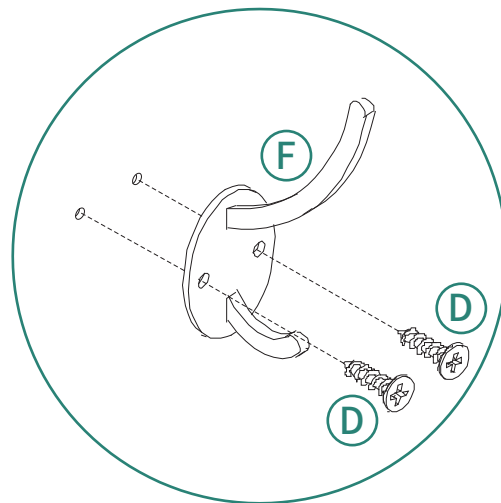
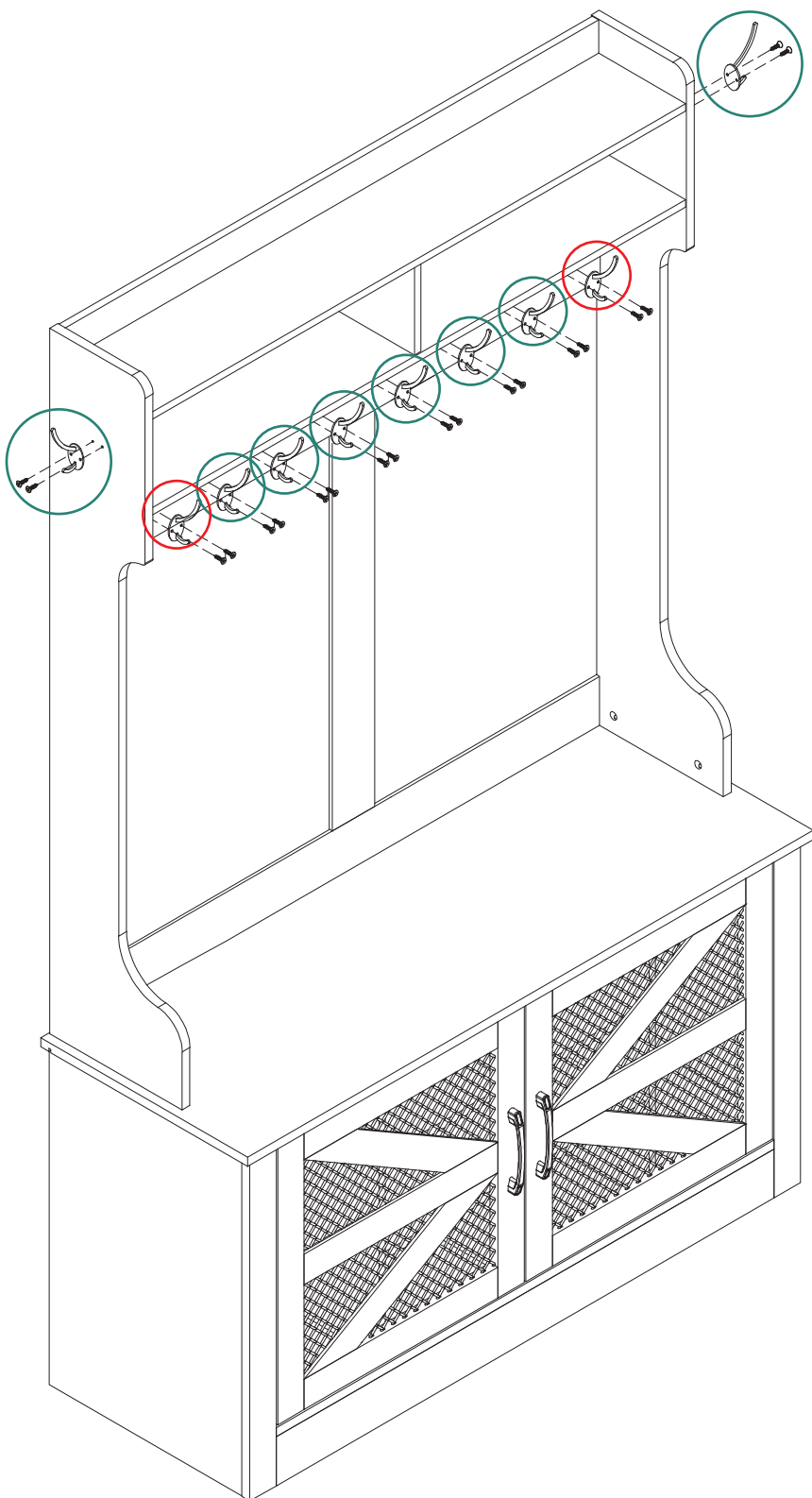

Installation Completed

Installation abgeschlossen

Installation complétée

Installazione completata

Instalación completada

# HELP CENTER



Inquiry



Assembly issue



Missing parts

If you encounter any difficulties during assembly, please contact us.

Wenn Sie während der Montage auf Schwierigkeiten stoßen, kontaktieren Sie uns bitte.

Si vous rencontrez des difficultés lors du montage, veuillez nous contacter.

Se incontri difficoltà durante il montaggio, ti preghiamo di contattarci.

Si encuentras alguna dificultad durante el ensamblaje, por favor contáctanos.

# DISCLAIMER

Manufacturer and seller expressly disclaim any and all liability for personal injury, property damage or loss, whether direct, indirect, or incidental, resulting from the incorrect attachment, improper use, inadequate maintenance, unapproved modification, or neglect of this product.

Der Hersteller und Verkäufer lehnen ausdrücklich jegliche Haftung für Personenschäden, Sachschäden oder Verluste ab, egal ob direkt, indirekt oder zufällig, die durch falsche Anbringung, unsachgemäßen Gebrauch, unzureichende Wartung, nicht genehmigte Änderungen oder Vernachlässigung dieses Produkts entstehen.

El fabricante y vendedor renuncian expresamente a toda responsabilidad por lesiones personales, daños materiales o pérdidas, ya sean directos, indirectos o incidentales, derivados de la incorrecta colocación, uso inadecuado, mantenimiento insuficiente, modificación no aprobada o negligencia de este producto.

Il produttore e il venditore declinano espressamente ogni responsabilità per lesioni personali, danni materiali o perdite, dirette, indirette o incidentali, derivanti dall'errato fissaggio, uso improprio, manutenzione inadeguata, modifica non autorizzata o negligenza di questo prodotto.

Le fabricant et le vendeur déclinent expressément toute responsabilité en cas de blessures corporelles, de dommages matériels ou de pertes, qu'ils soient directs, indirects ou accessoires, résultant de la fixation incorrecte, de l'utilisation inappropriée, de l'entretien insuffisant, de la modification non approuvée ou de la négligence de ce produit.