

IMPORTANT INSTRUCTIONS AND OPERATING MANUAL

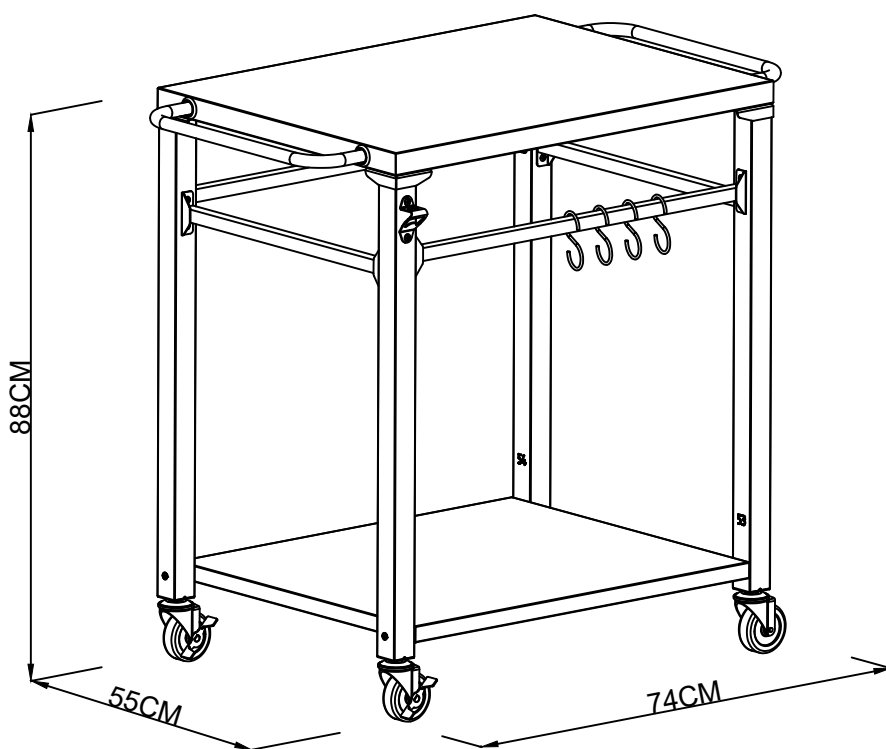

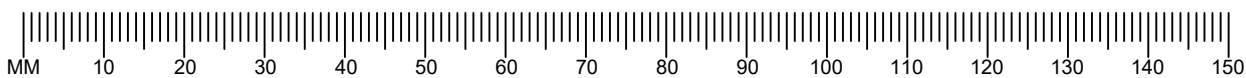



Model: GA8105

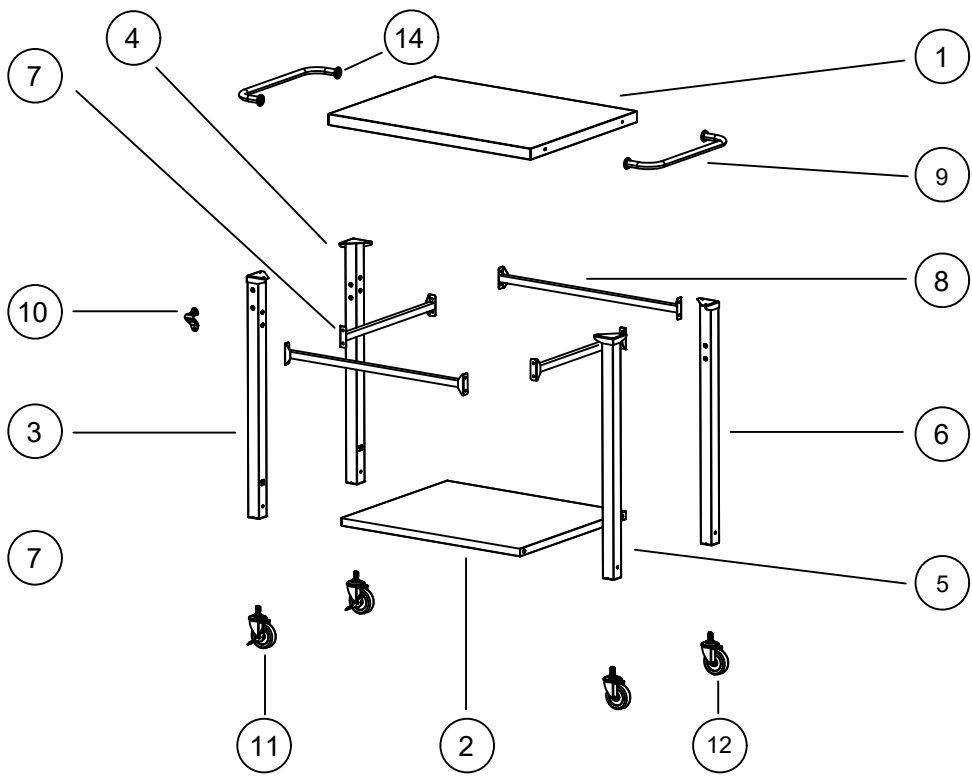



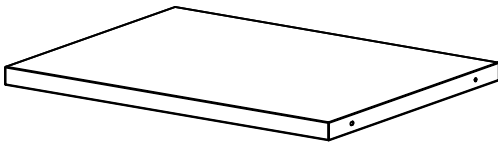
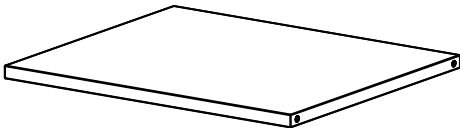
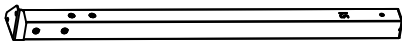
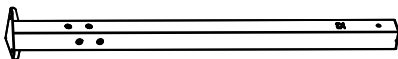
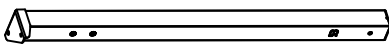
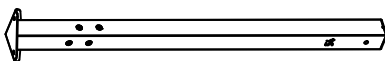

PACKAGE CONTENTS (GA8105)





PACKAGE CONTENTS (GA8105)

| No. | Parts Name | Parts Diagram | Qty. |
|-----|-------------------------|--|------|
| 1 | Table |  | 1 |
| 2 | Bottom shelf |  | 1 |
| 3 | Left front leg tube |  | 1 |
| 4 | Left hindleg tube |  | 1 |
| 5 | Right front leg pipe |  | 1 |
| 6 | Right rear leg cylinder |  | 1 |
| 7 | Right left brace |  | 2 |
| 8 | Front back brace |  | 2 |
| 9 | Lid handle |  | 2 |

PACKAGE CONTENTS (GA8105)

| No. | Parts Name | Parts Diagram | Qty. |
|-----|-------------------------------|---|------|
| 10 | Bottle opener |  | 1 |
| 11 | Spinner wheel |  | 2 |
| 12 | Spinner wheels without brakes |  | 2 |
| 13 | Hook |  | 4 |
| 14 | Gasket |  | 4 |

| Hardware Contents | | | |
|-------------------|-------------|--|----|
| AA | M6x12 Screw |  | 28 |
| BB | M6x12 Screw |  | 2 |
| CC | M6x50 Screw |  | 4 |

PREPARATION

Before beginning assembly of the product, ensure that all parts are present. Compare the included components with the package contents list on the previous page. If any part is missing or damaged, do not attempt to assemble the product. Contact customer service for replacement parts.

Estimated Assembly Time: 15 minutes (requires two people)

Tools Required for Assembly and Leak Testing (not included):

Phillips screwdriver

Spray bottle

Pliers

Adjustable wrench

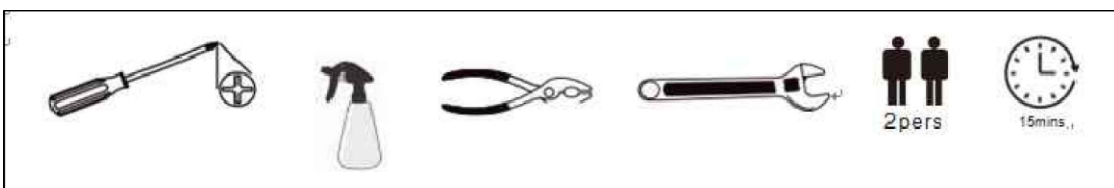

CAUTION

- HEAVY UNIT: This product is heavy. Two people are required for safe assembly.
- Some parts may have sharp edges. Wear protective gloves if necessary.
- Carefully read and follow all safety guidelines, warnings, assembly instructions, and usage instructions before attempting assembly or use.

1.

AA M6X12  4X

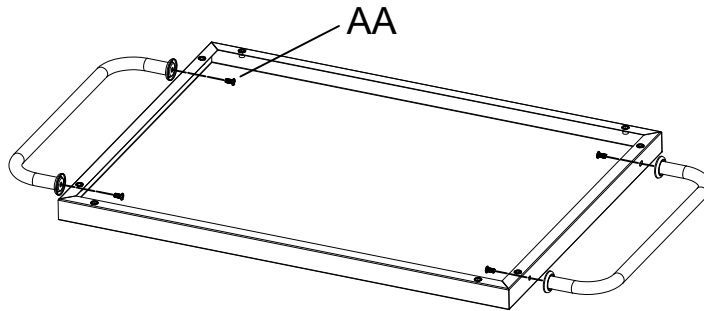

2.

AA M6X12  8X

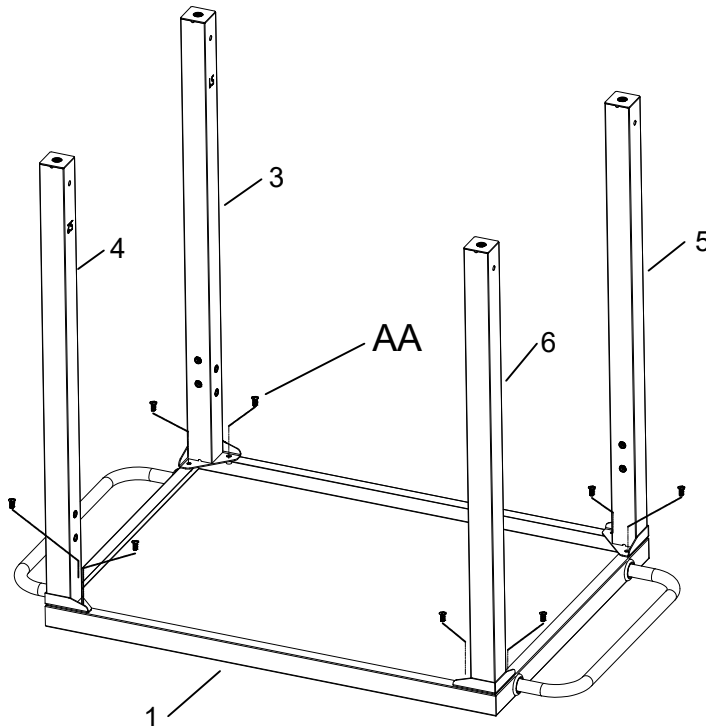

3.

AA M6X12



16X

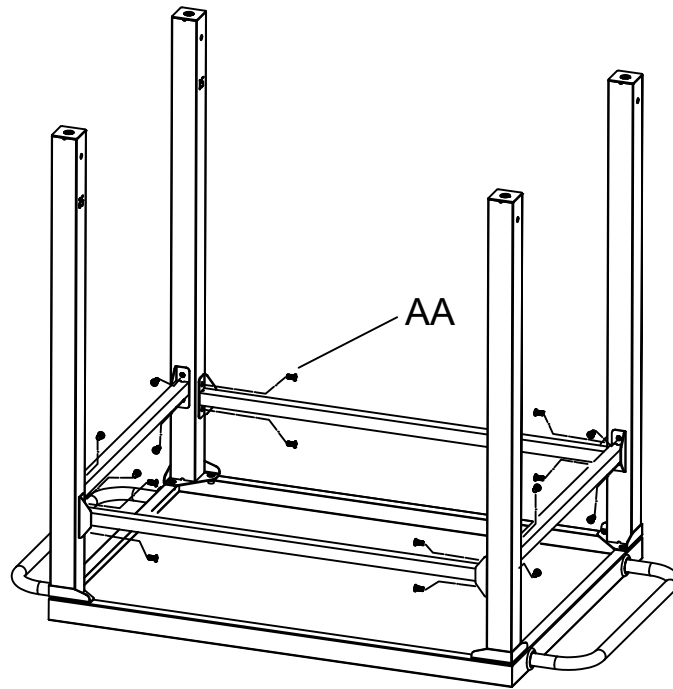

4.

CC M6X50



4X

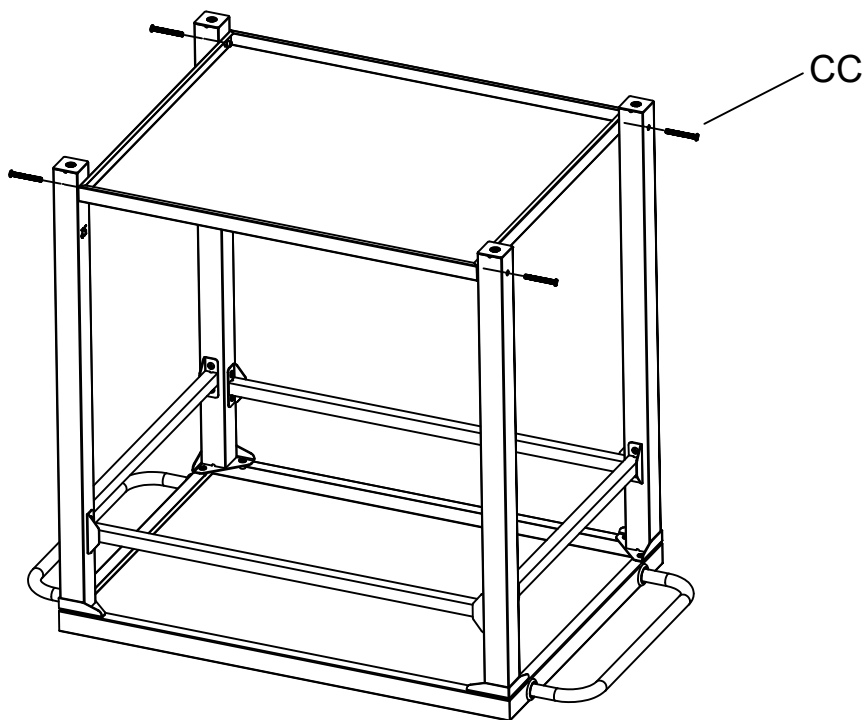

5.

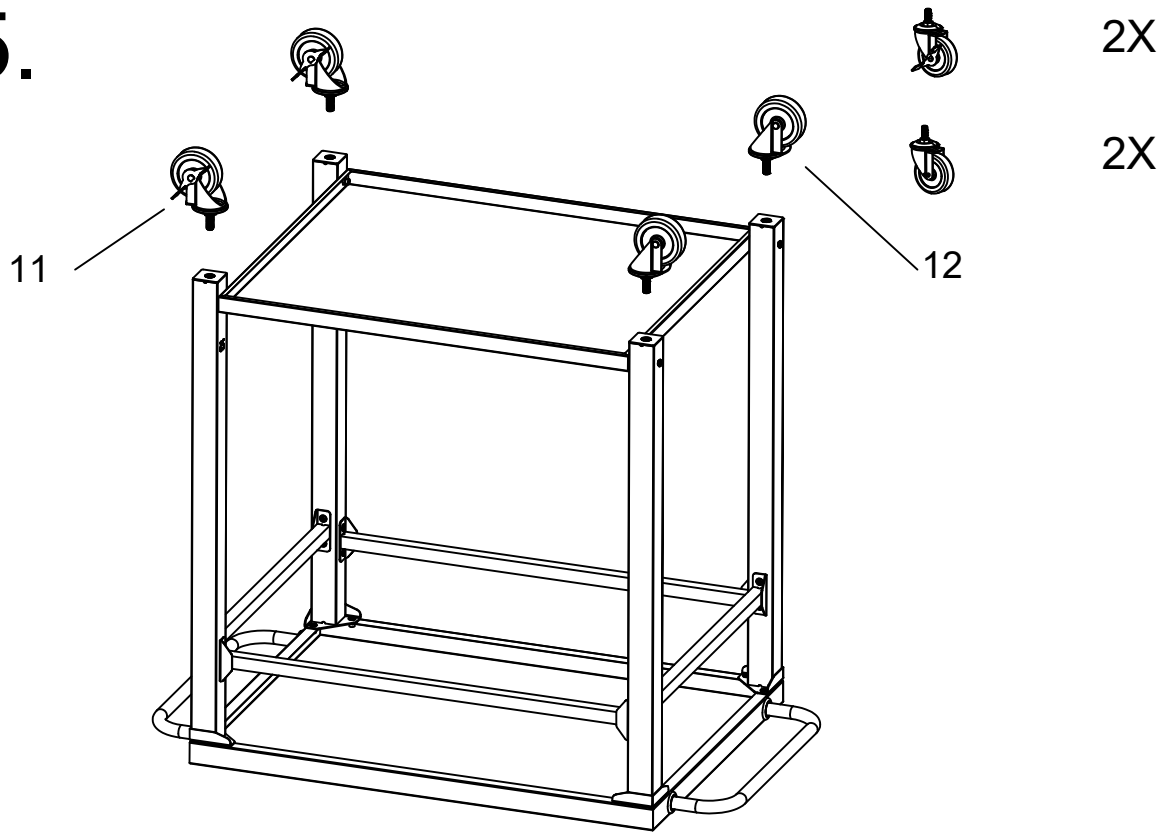

6.

BB M6X12 2X

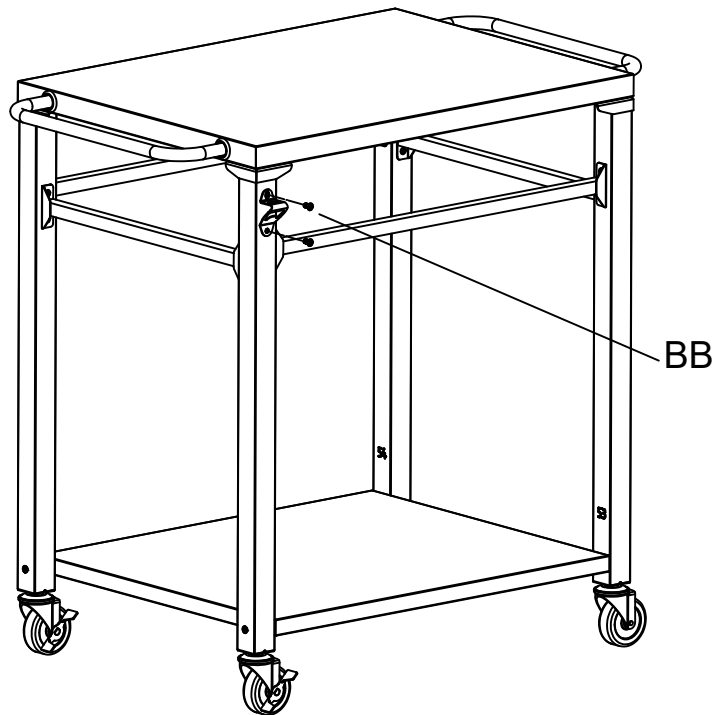

7.

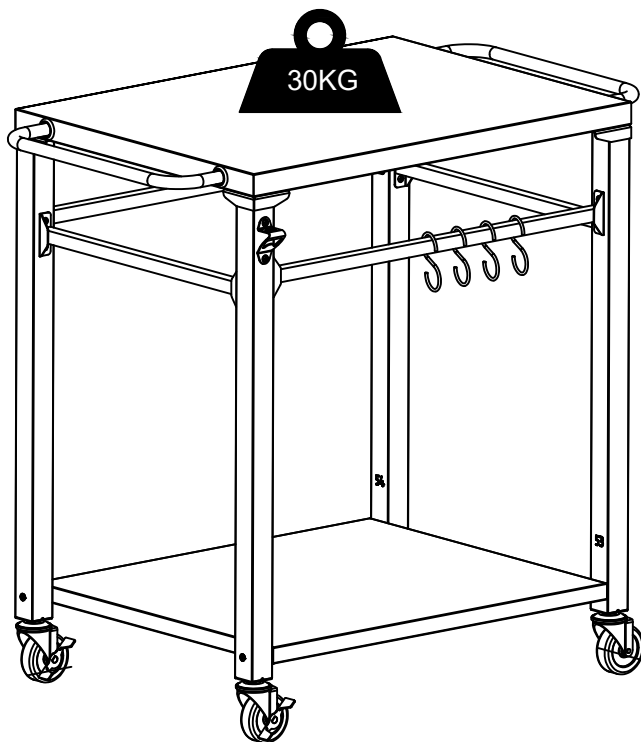

! SAFETY INFORMATION

Thank you for purchasing this product!
If you have any suggestions for the product,
plsase send an email to ✉ kommokasa01@gmail.com