

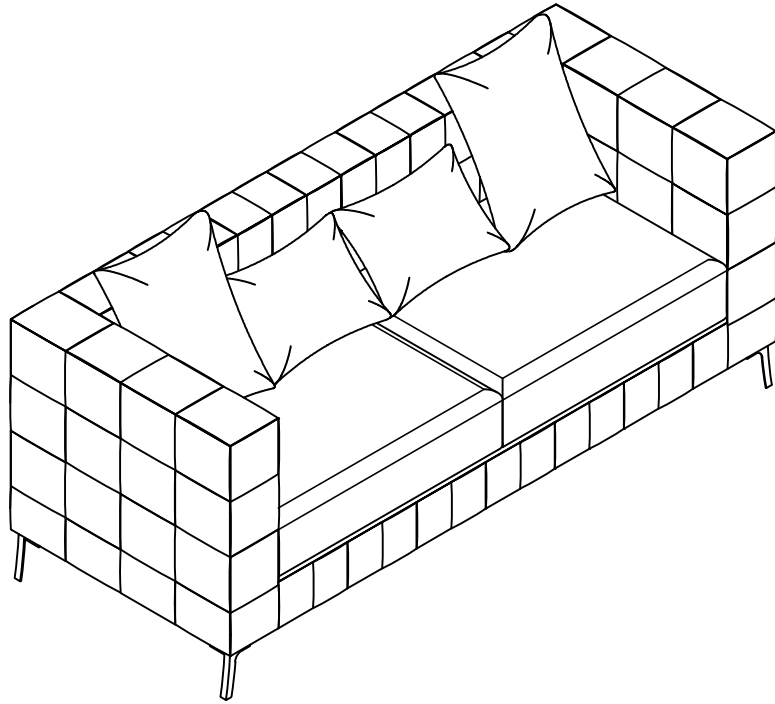

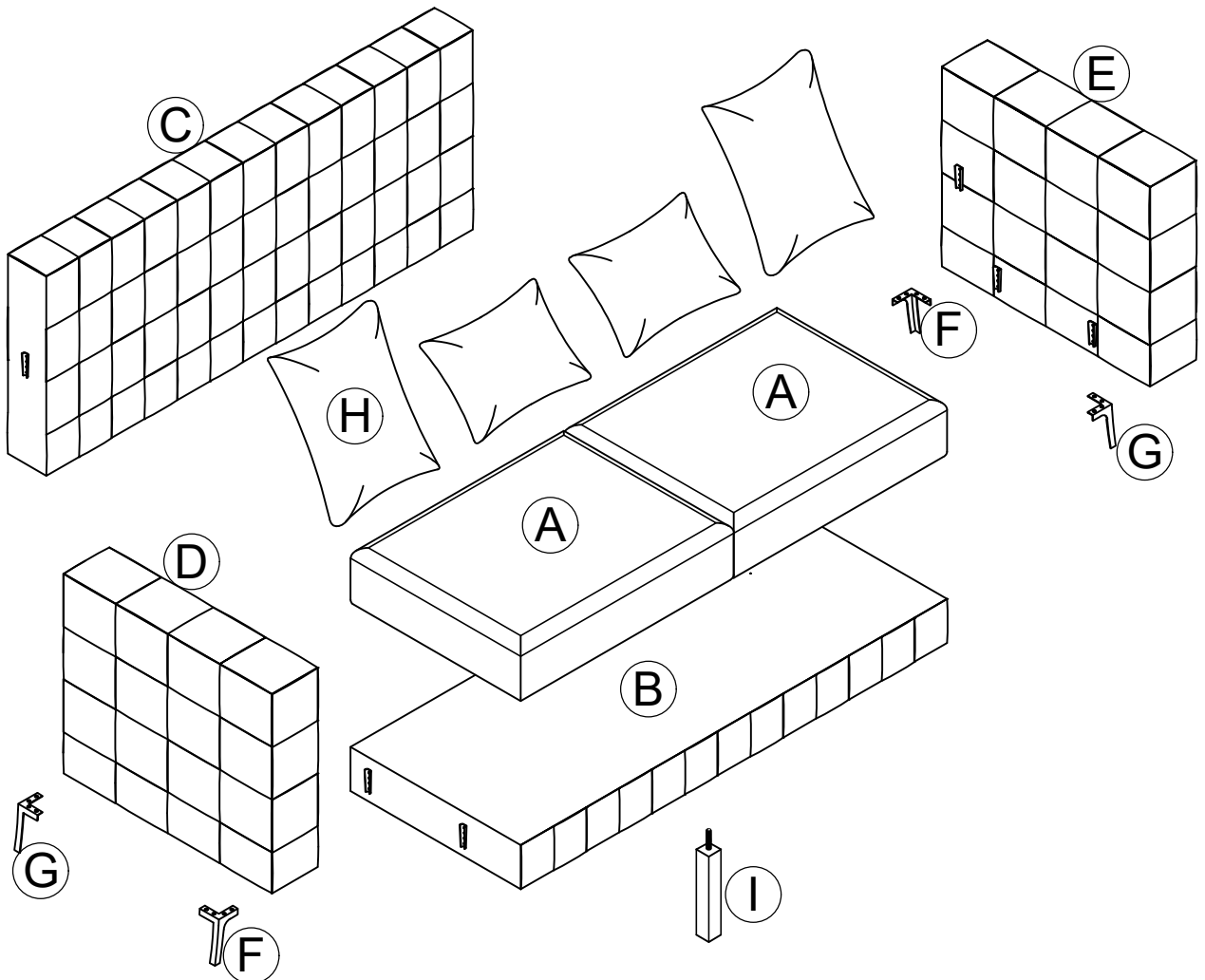

ASSEMBLY UNTRUCTION



PARTS

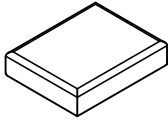

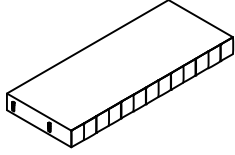
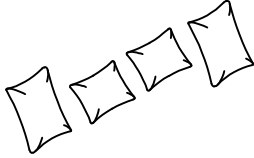

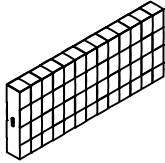
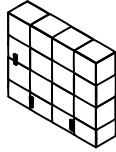
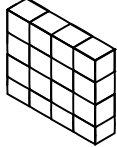

PARTS LIST-WF305979

| PARTS | DRAWING | DESCRIPTION | QTY | PARTS | DRAWING | DESCRIPTION | QTY |
|-------|-----------------------------------------------------------------------------------|--------------|-----|-------|-------------------------------------------------------------------------------------|-------------|-----|
| A |  | Cushion seat | 02 | G |  | Right leg | 02 |
| B |  | Seat frame | 01 | H |  | Pillow | 04 |
| F |  | Left leg | 02 | I |  | Support leg | 01 |

PARTS LIST-WF305978

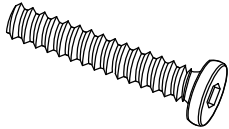
| PARTS | DRAWING | DESCRIPTION | QTY | PARTS | DRAWING | DESCRIPTION | QTY |
|-------|-------------------------------------------------------------------------------------|-------------|-----|-------|--------------------------------------------------------------------------------------|-------------|-----|
| C |  | Back frame | 01 | E |  | Right arm | 01 |
| D |  | Left arm | 01 | | | | |

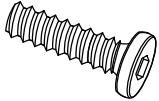
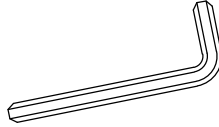
HARDWARE LIST -WF305978

| PARTS | DRAWING | DESCRIPTION | QTY | PARTS | DRAWING | DESCRIPTION | QTY |
|-------|-------------------------------------------------------------------------------------|------------------------------|-----|-------|---------------------------------------------------------------------------------------|------------------------------|-----|
| 1 |  | Bolt Ø5/16" x 60mm | 04 | 4 |  | Flat washer Ø5/16" x 19mm | 20 |
| 2 |  | Bolt Ø5/16" x 25mm | 16 | 5 |  | Allen key | 01 |
| 3 |  | Spring washer Ø5/16"x16mm | 04 | | | | |

STEP 1:

Place all part on a clean, smooth face.

Take the pillow (H) right leg(G), left Leg (F) out from under the seat frame (B).

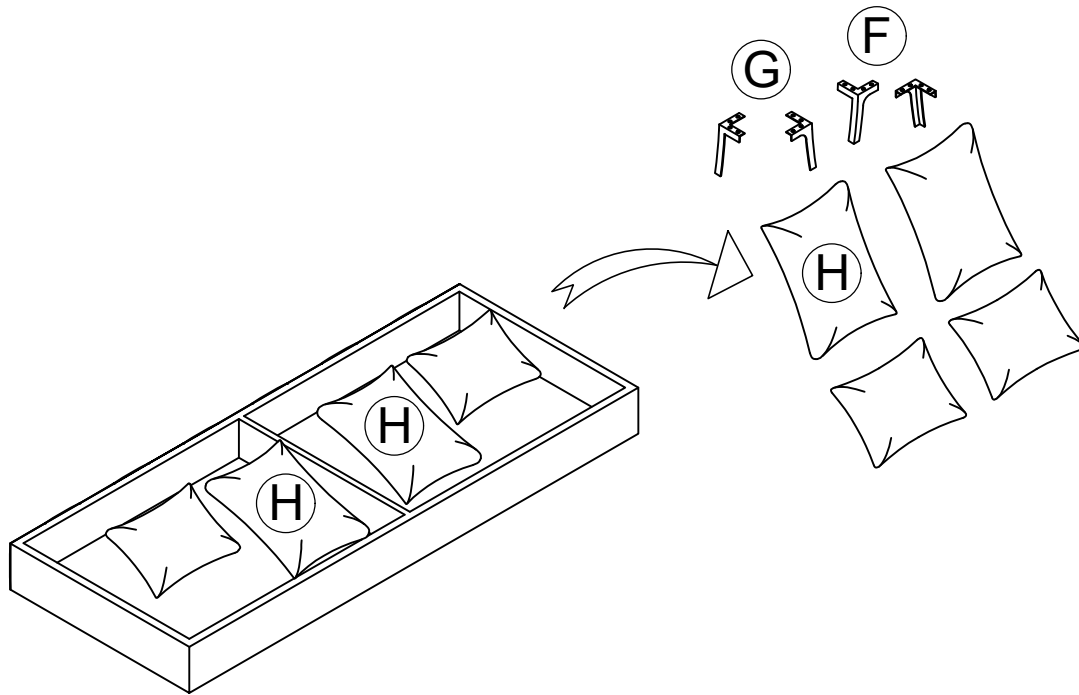

STEP 2:

Place all part on a clean, smooth face.

attach the right leg (G) and left leg (F) to the right arm (E) and left arm (D) using the bolt (2) and flat washer (4) and Allen key (5) to tighten it..

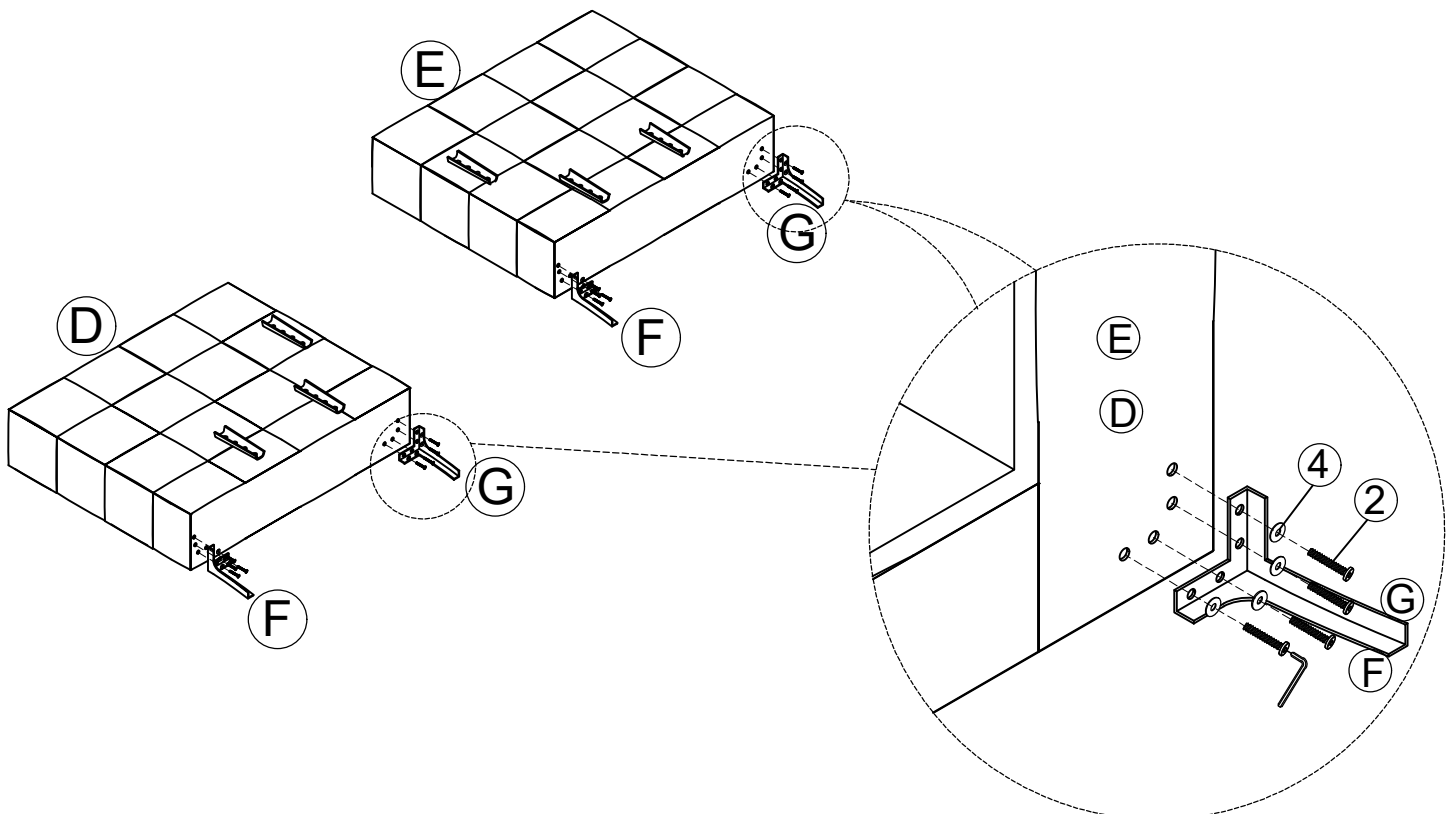

STEP 3:

Place all part on a clean, smooth face.

Attach the Seat frame (B) to the left Arm (D) and right Arm (E) by pushing the metal on the seat frame(B) into the metal on the side arm left and right.

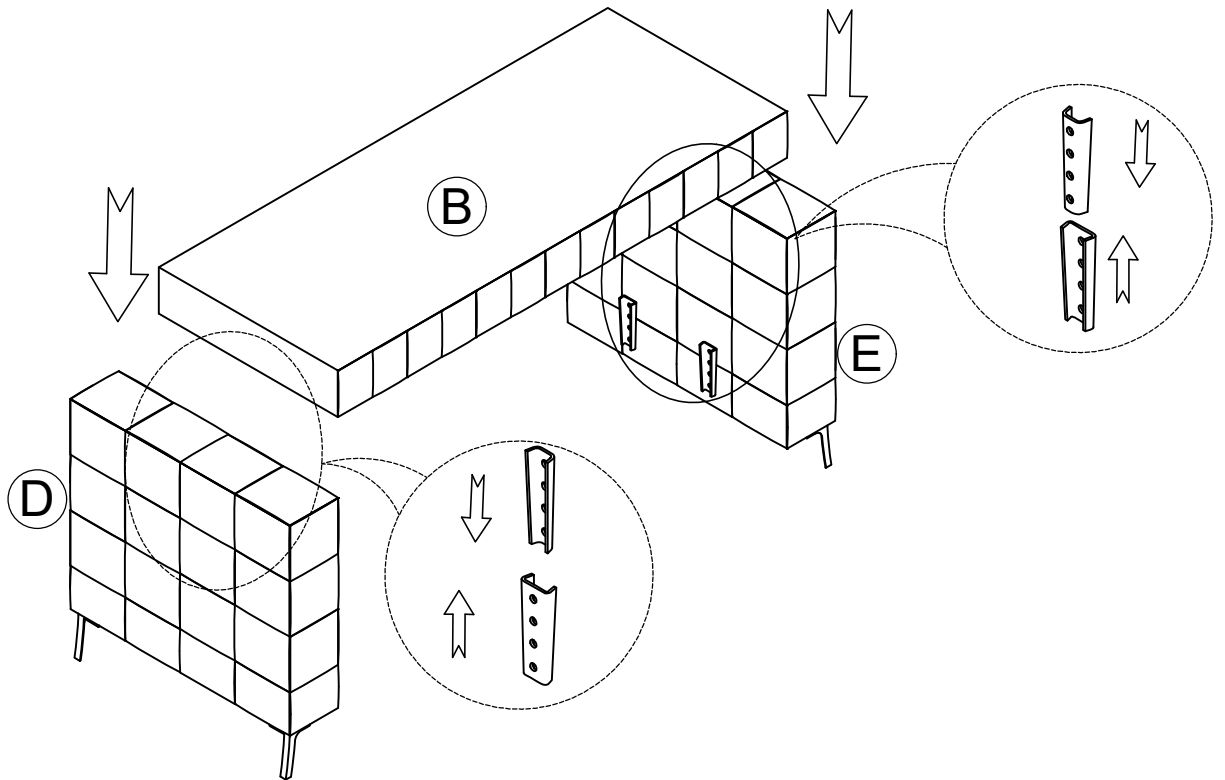

STEP 4:

Attach the back frame (C) to the left Arm (D) and right Arm (E) by pushing the metal on back the frame (C) into the metal on the arm left and right.

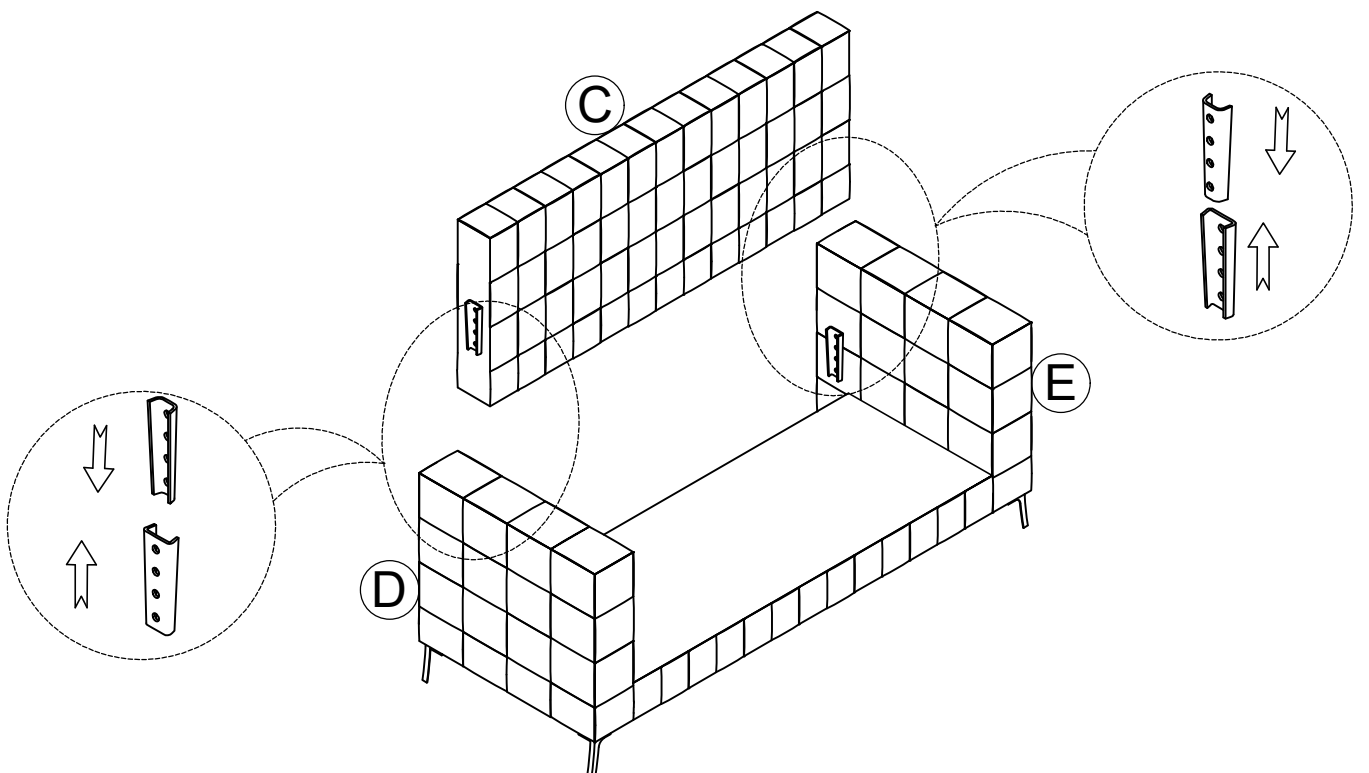

STEP 5:

Tighten the back frame (C) to the seat frame (B) by bolt (1) and spring washer (3) and flat washer (4) and Allen key (5).

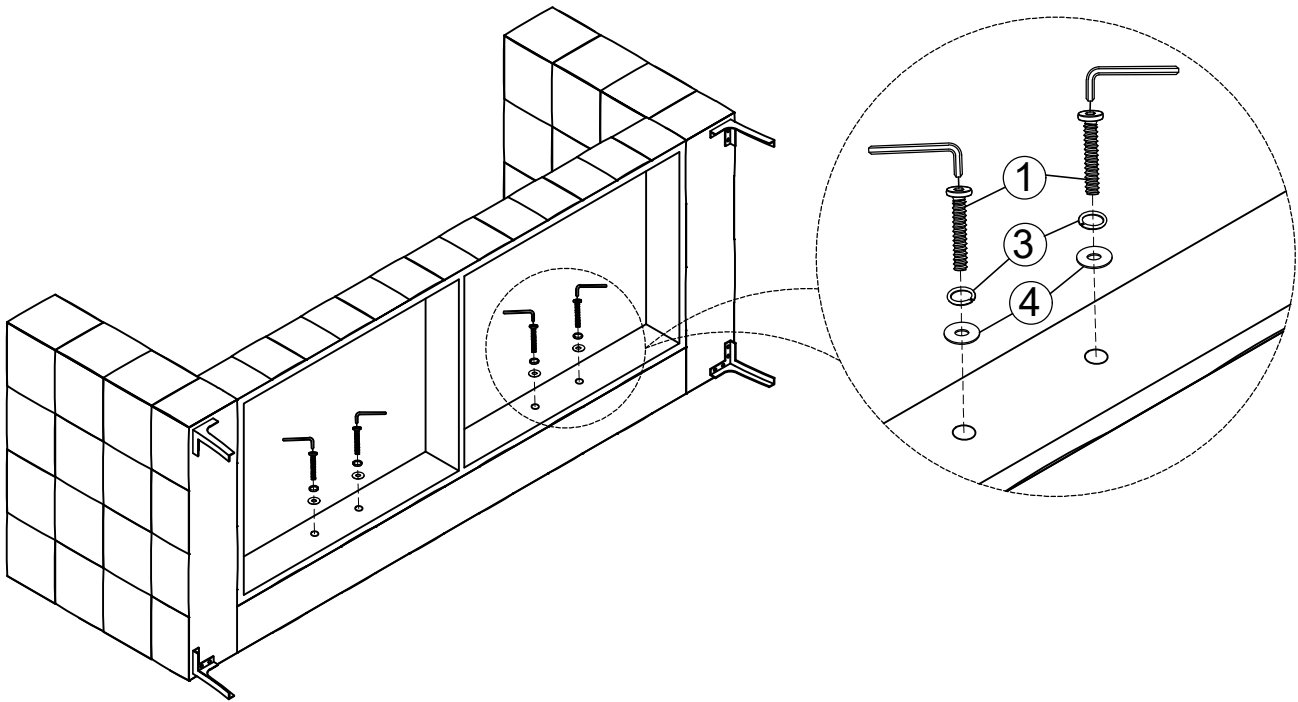

STEP 6:

Attach the Support leg (I) to the Seat frame (B).

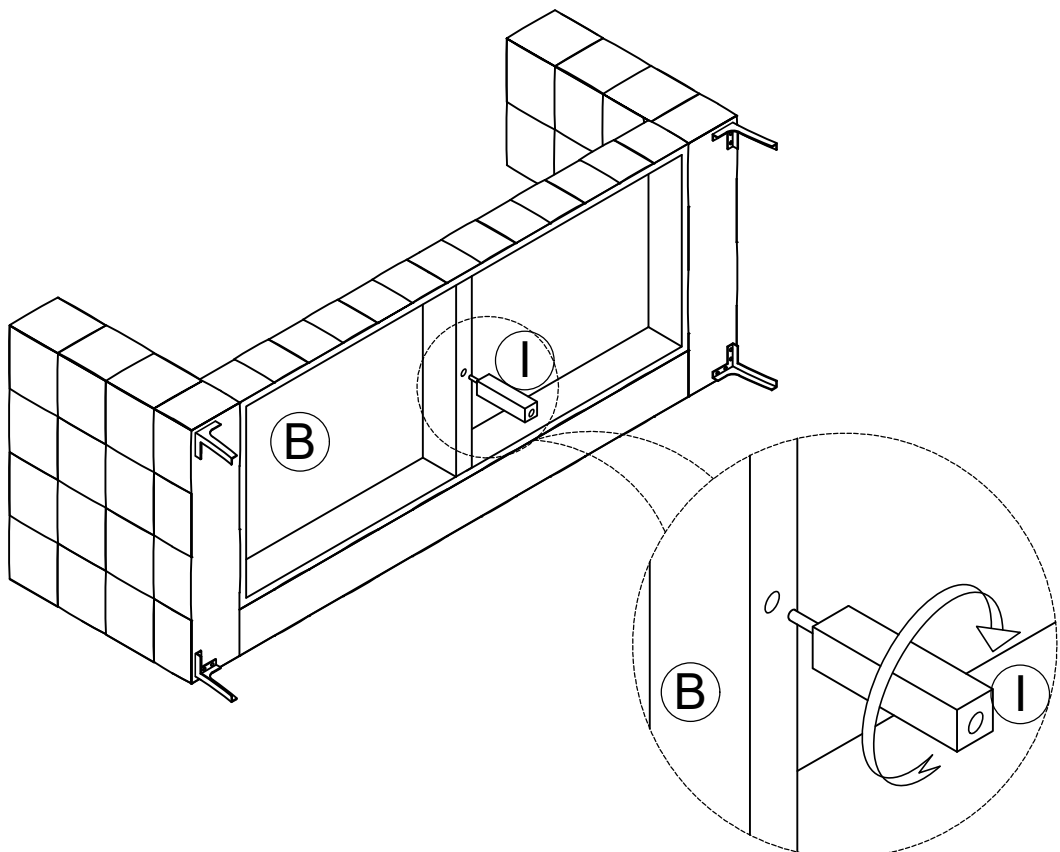

STEP 7:

Put the cushion (A) into the seat frame (B).

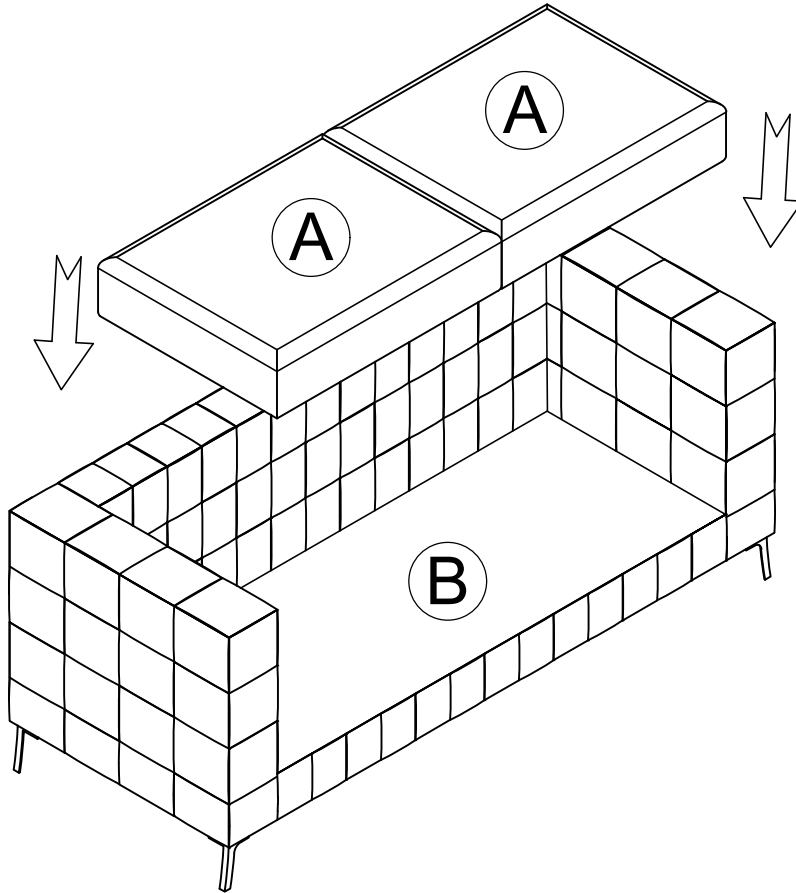

STEP 8:

Put the pillow (H) into the cushion seat (A) then complete assembly instruction.

