

INSTRUCTION MANUAL

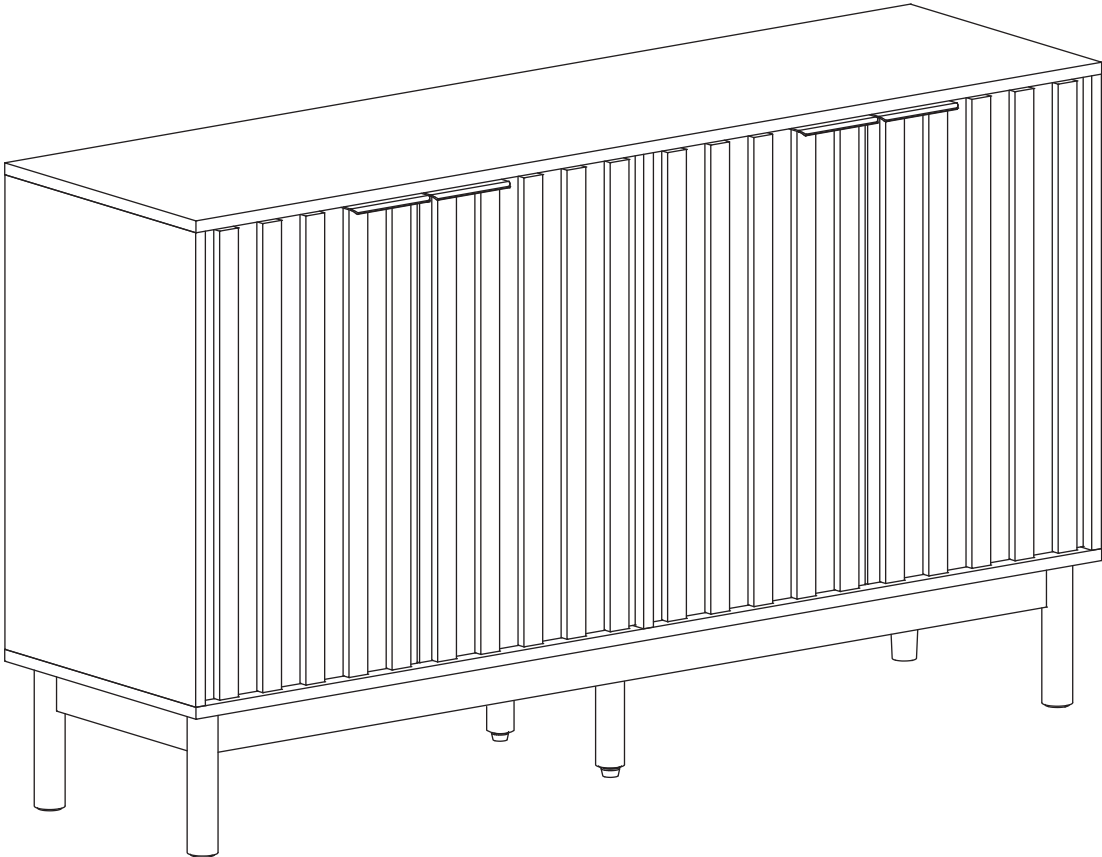

! **NOTICE** Please retain these instructions for future reference.

- Carefully unpack all the components and verify that all the necessary parts are included as listed in the packaging.
- Identify each component and refer to the provided assembly diagram or step-by-step instructions.
- Assemble the furniture in the order specified to ensure proper alignment and fit.
- Use the provided tools or recommended tools for assembly. Do not use excessive force when tightening screws or bolts.
- If any difficulties arise during assembly. Consult the troubleshooting section or contact our customer support.

ASSEMBLY INSTRUCTIONS

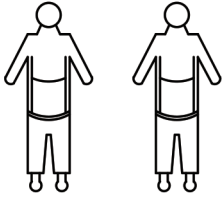



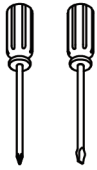



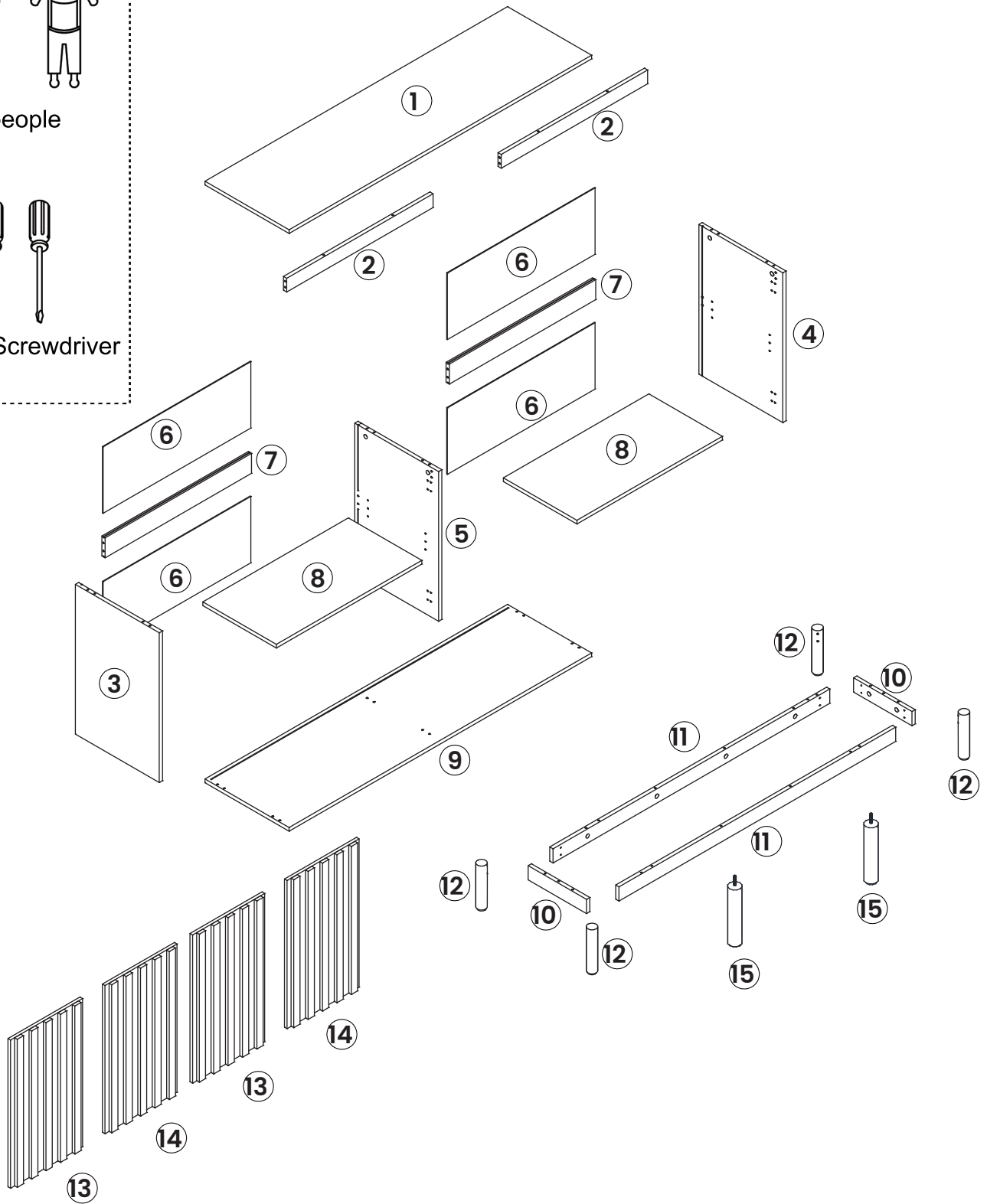



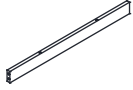



2 people

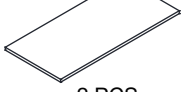

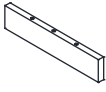



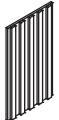





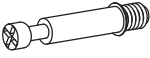



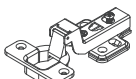

Phillips Screwdriver

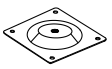

☰ PARTS LIST

- | | | | | | |
|--|---|---|--|---|---|
| 01
Top Panel

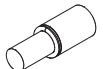
1 PC | 02
Stretcher

2 PCS | 03
Left Side Panel

1 PC | 04
Right Side Panel

1 PC | 05
Partition Panel

1 PC | 06
Back Panel

4 PCS |
| 07
Stretcher

2 PCS | 08
Shelf

2 PCS | 09
Bottom Panel

1 PC | 10
Stretcher

2 PCS | 11
Stretcher

2 PCS | 12
Leg

4 PCS |
| 13
Left Door Panel

2 PCS | 14
Right Door Panel

2 PCS | 15
Leg

2 PCS | | | |

☰ HARDWARE LIST

A Ø6x35mm Cam Bolt  34+2 PCS	B Ø15x10mm Cam Lock  34+2 PCS	C Ø6x30mm Dowel  20+2 PCS	D Ø4x35mm Screw  6+1 PCS	E Ø3.5x12mm Screw  56+2 PCS	F Hinge  8 PCS
G Ø6x50mm Dowel  1+1 PCS	H  4 PCS	I Ø4x12mm Screw  24+2 PCS	J Ø6x40mm Bolt  8+1 SETS	K Allen Key  1 PC	L Floor Pads  4+1 PCS
M  2 PCS	N Leveler  2 PCS	O Back Buckle  16+1 PCS	P Back Buckle Screw  16+1 PCS	Q Stickers  6 PCS	R Anti-Fall Strip Large Flat Head Screw R-1 R-2 R-3 Washer 2 PCS
S Self-Tapping Screw Plastic Expansion S-1 S-2 S-3 Washer 2 PCS	T Pin  8+1 PCS	U Hold Hands  4 PCS	V Silicone Pad  4+1 PCS		

! If you are missing any parts, please provide your order number and circle the part number. Send us a photo of this, and we will provide you with a satisfactory solution. Thank you.

STEP 1

Please tighten the screws after completing all installation.

Por favor, apriete los tornillos después de instalar todo.

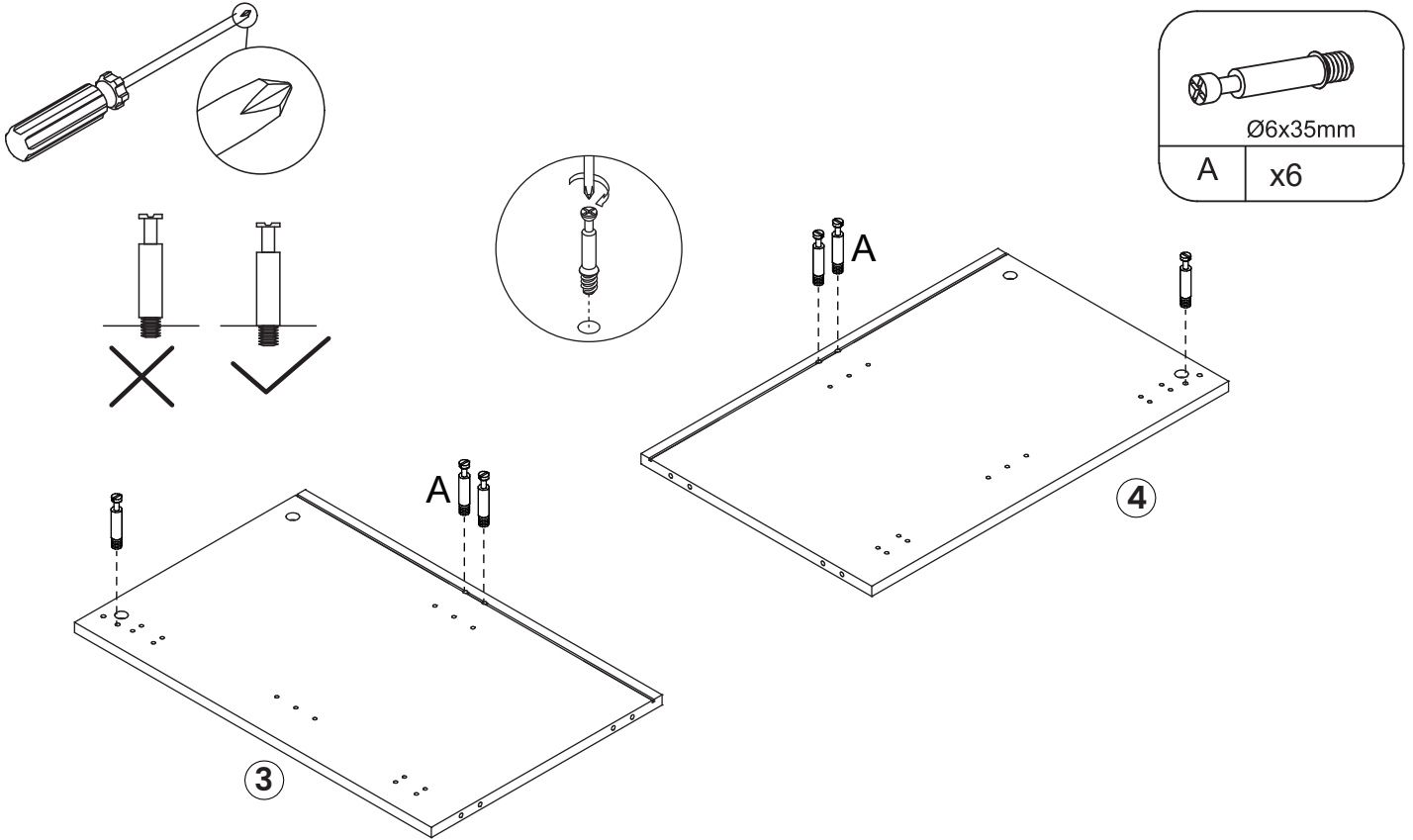

STEP 2

Please tighten the screws after completing all installation.

Por favor, apriete los tornillos después de instalar todo.

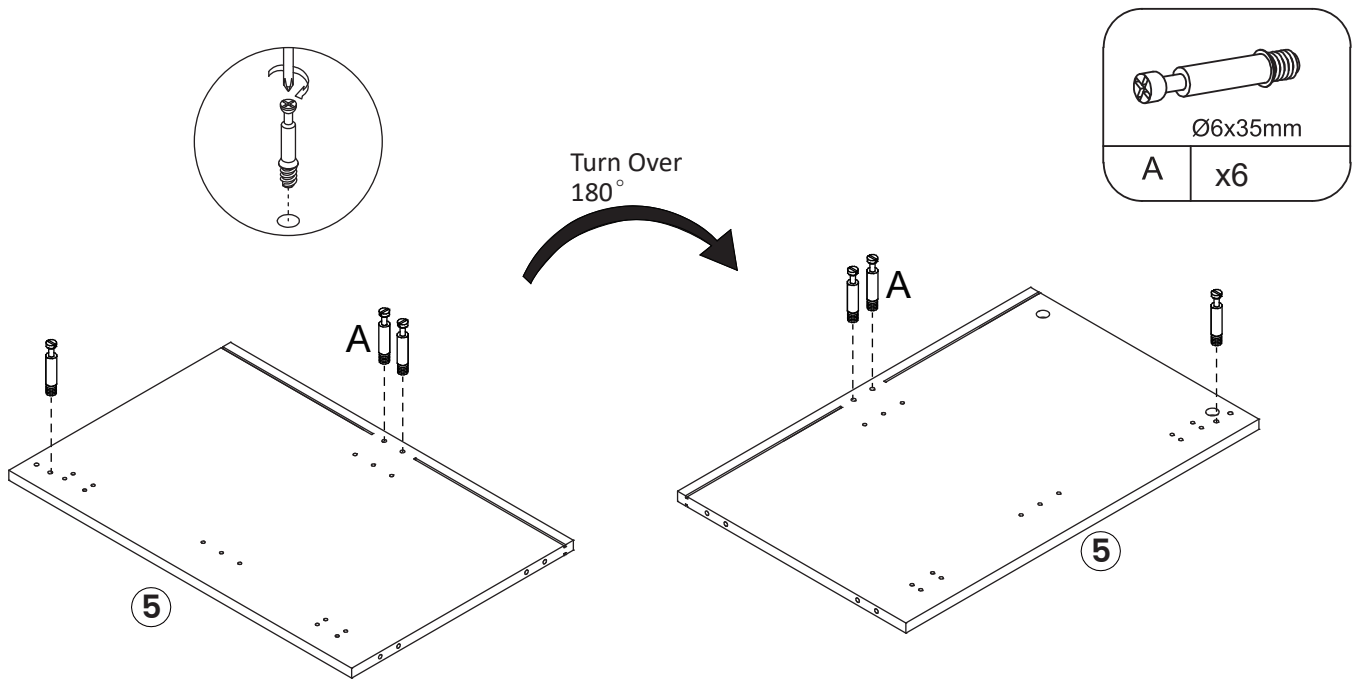

STEP 3

Please tighten the screws after completing all installation.

Por favor, apriete los tornillos después de instalar todo.

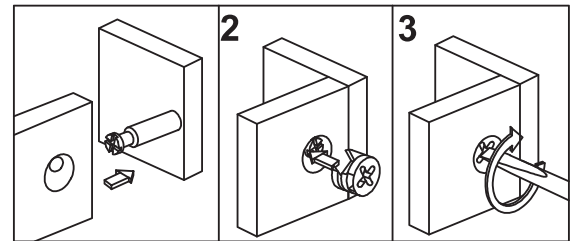
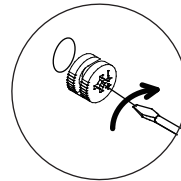
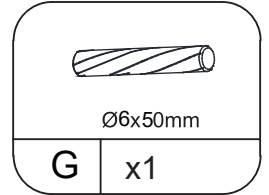
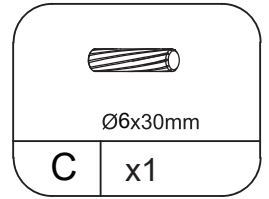
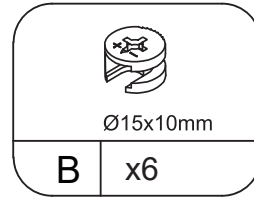
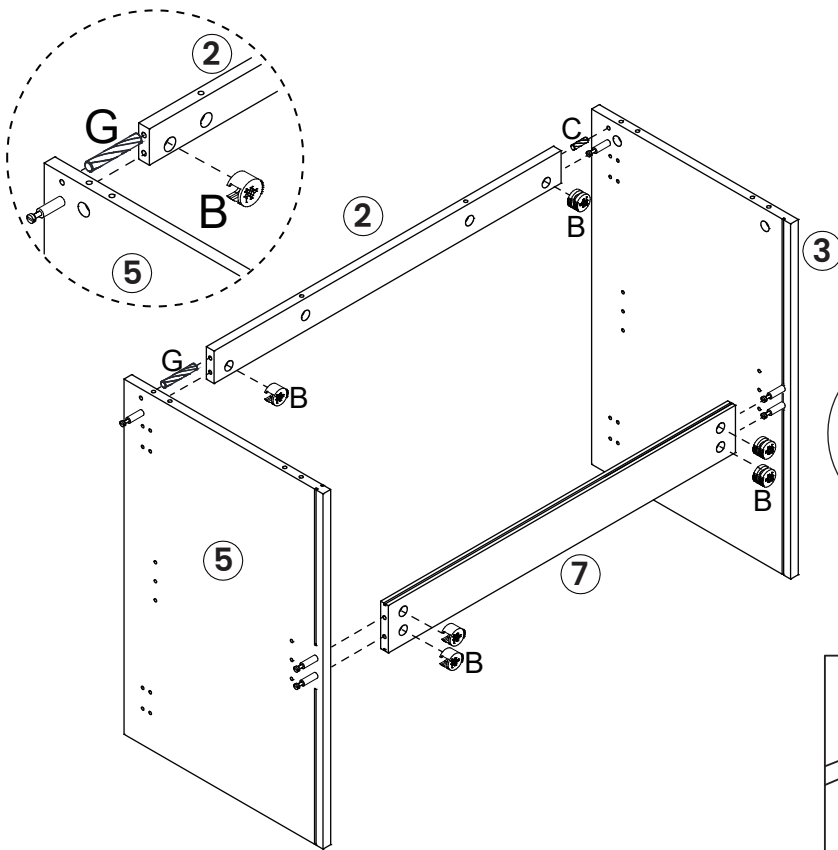

STEP 4

Please tighten the screws after completing all installation.

Por favor, apriete los tornillos después de instalar todo.

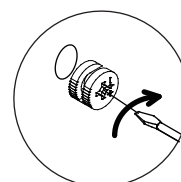
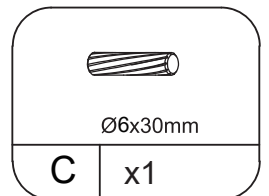
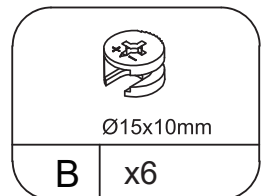
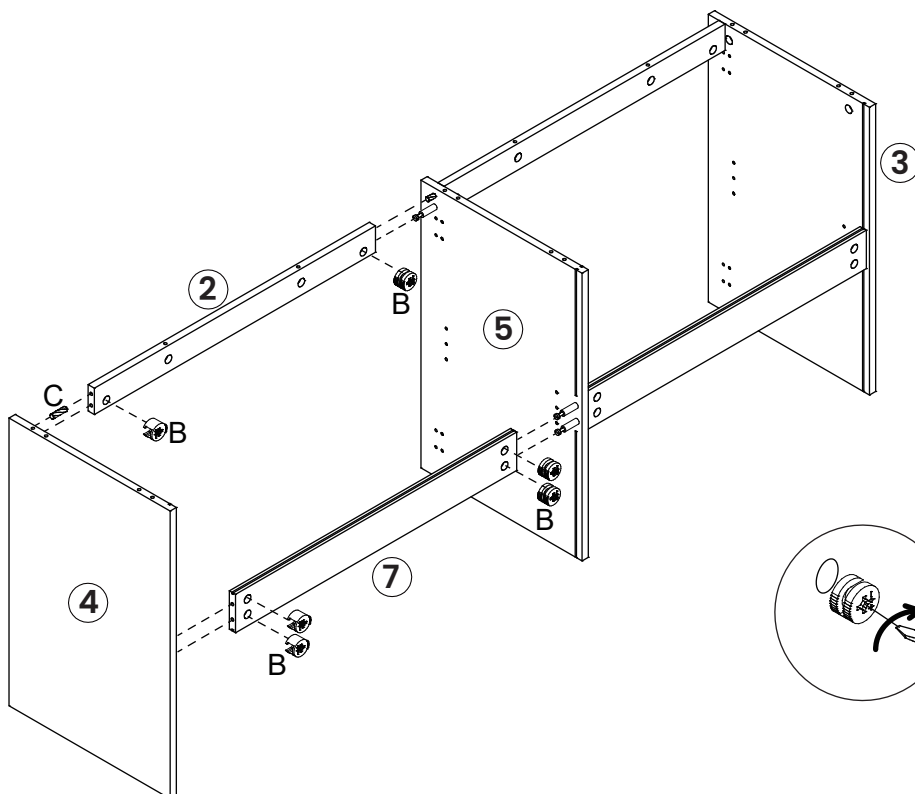

STEP 5

Please tighten the screws after completing all installation.

Por favor, apriete los tornillos después de instalar todo.

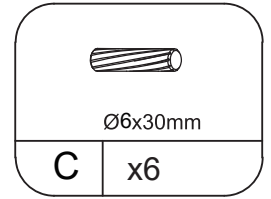
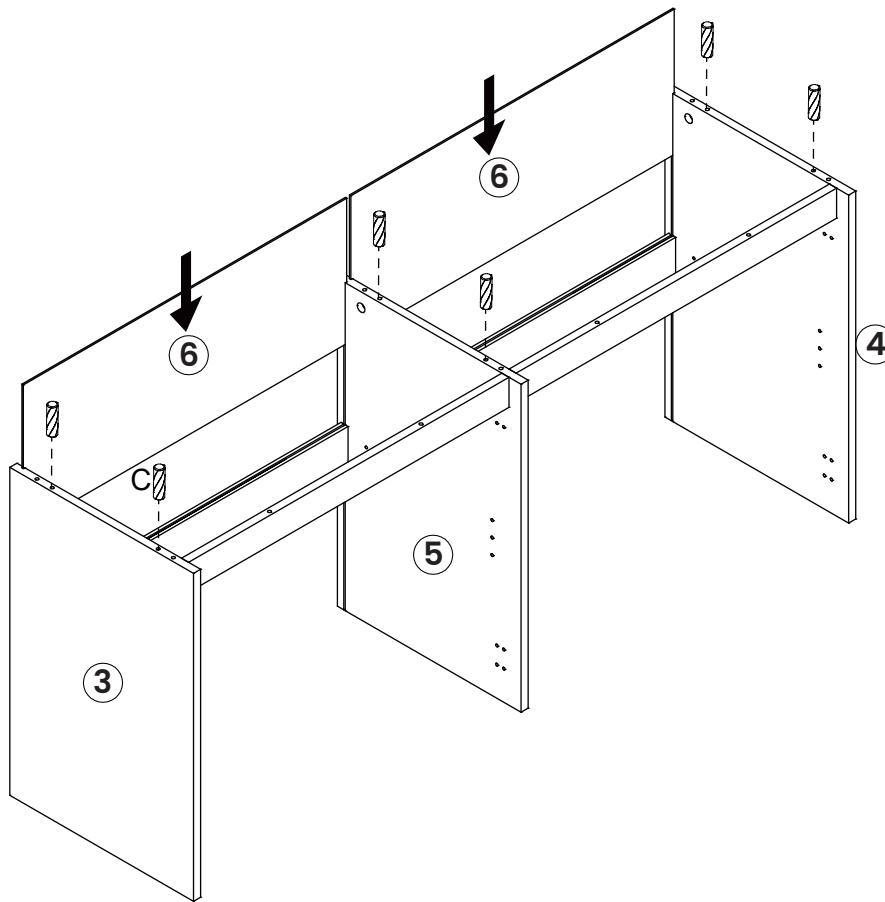

STEP 6

Please tighten the screws after completing all installation.

Por favor, apriete los tornillos después de instalar todo.

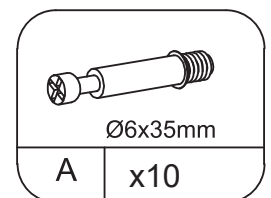
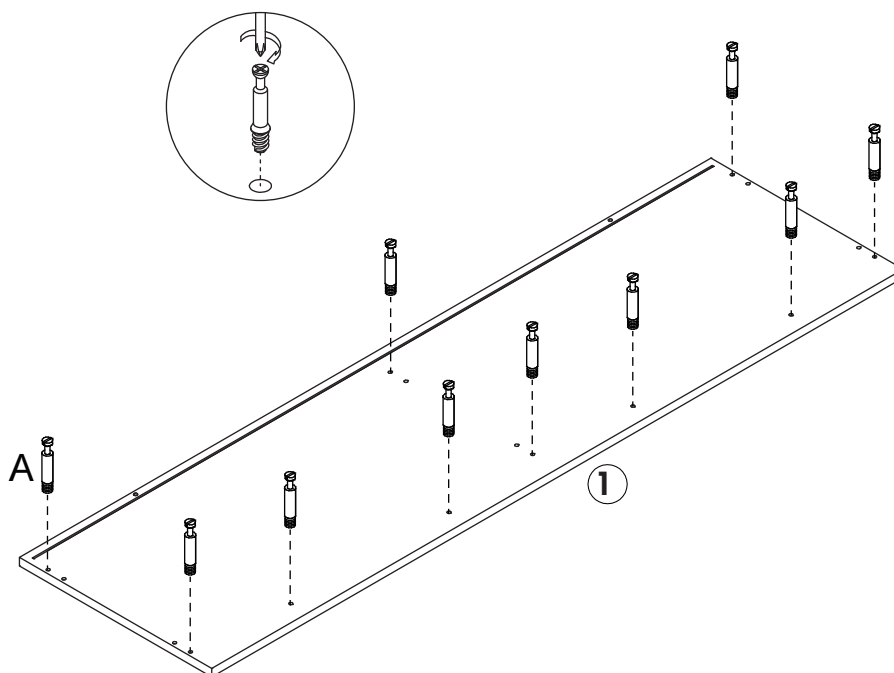

STEP 7

Please tighten the screws after completing all installation.

Por favor, apriete los tornillos después de instalar todo.

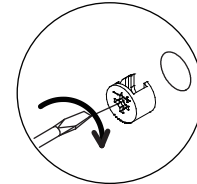
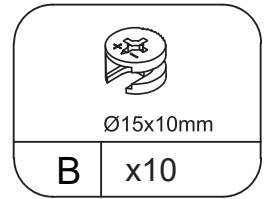
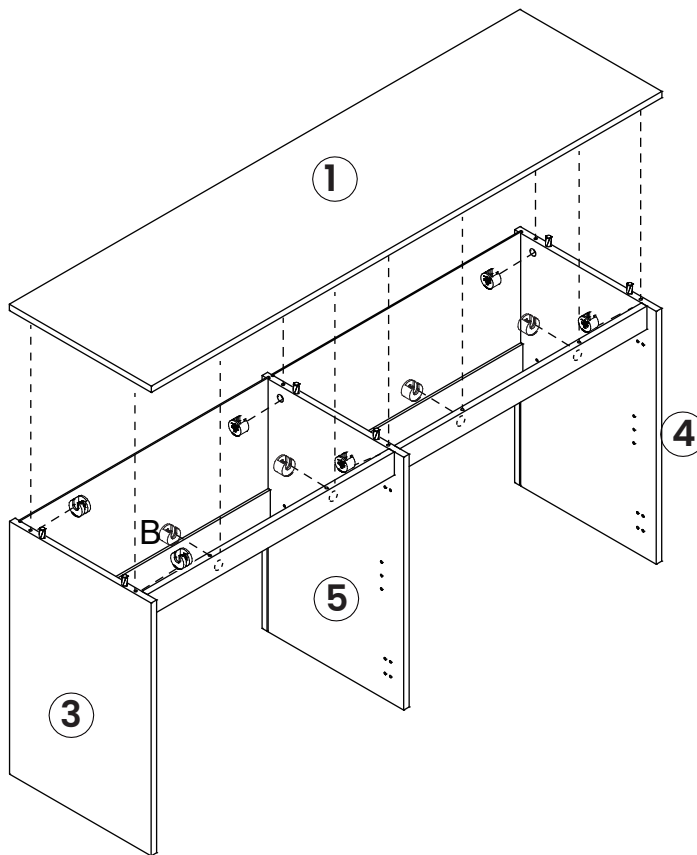

STEP 8

Please tighten the screws after completing all installation.

Por favor, apriete los tornillos después de instalar todo.

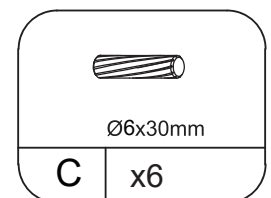
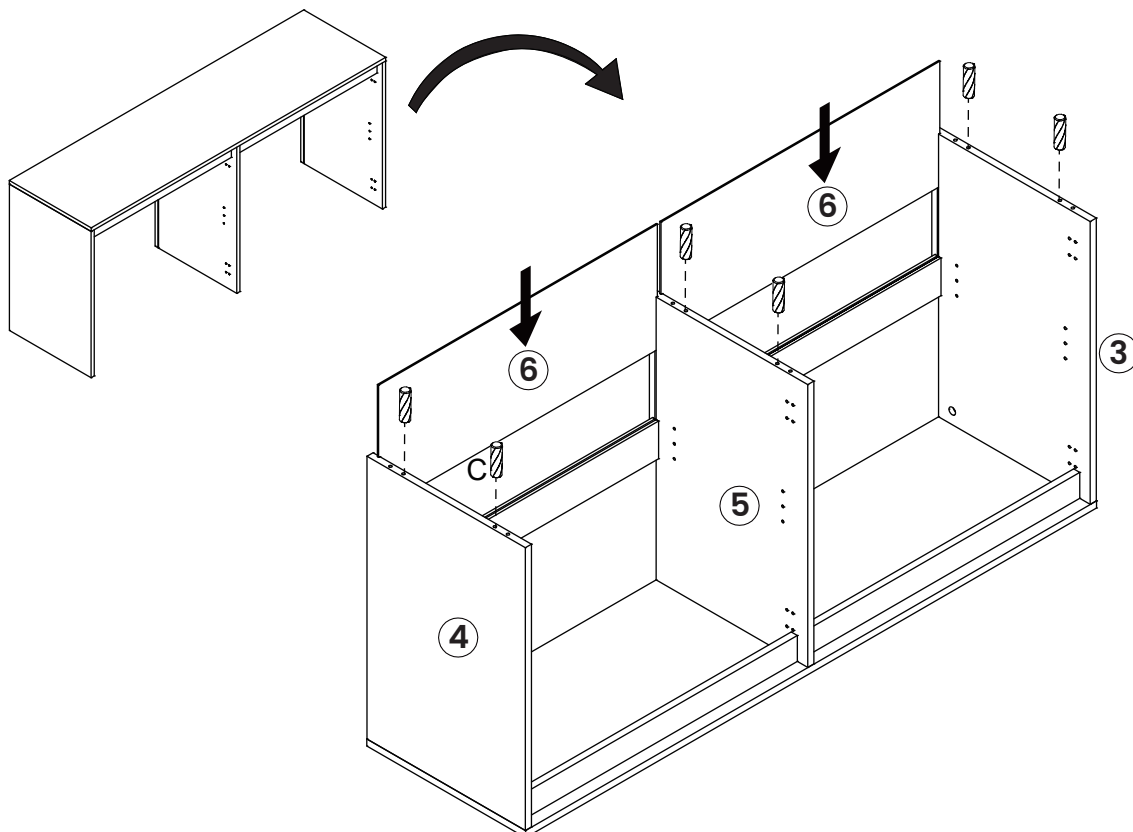

STEP 9

Please tighten the screws after completing all installation.

Por favor, apriete los tornillos después de instalar todo.

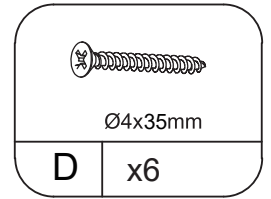
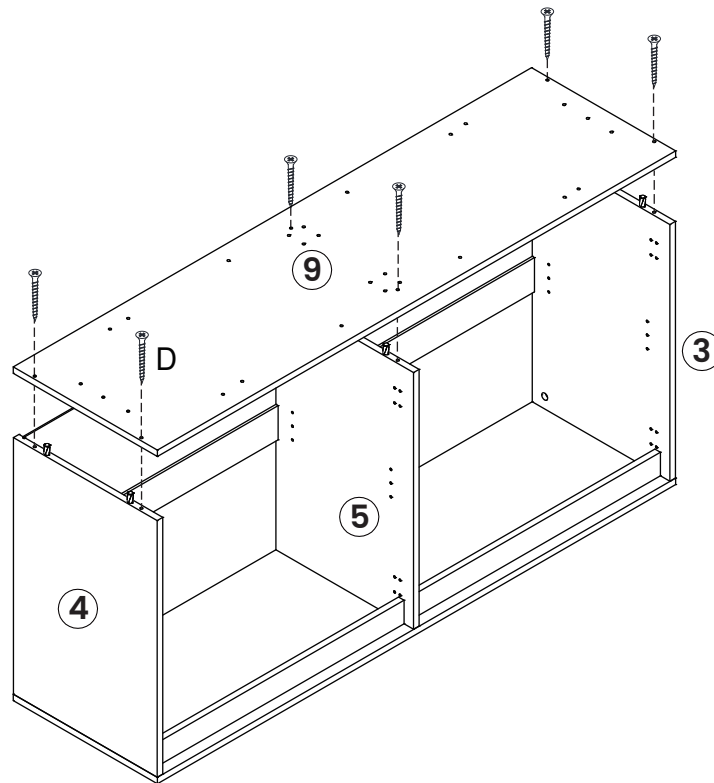

STEP 10

Please tighten the screws after completing all installation.

Por favor, apriete los tornillos después de instalar todo.

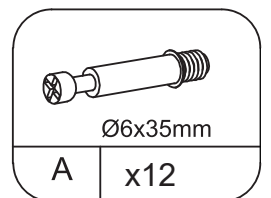
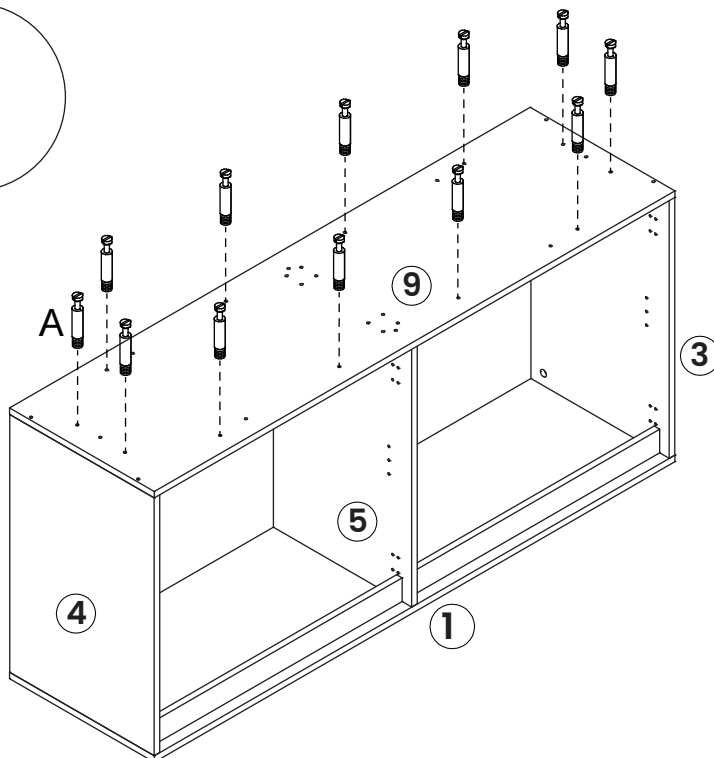
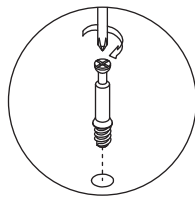

STEP 11

Please tighten the screws after completing all installation.

Por favor, apriete los tornillos después de instalar todo.

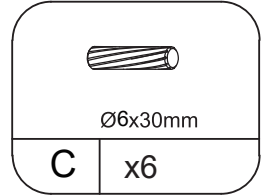
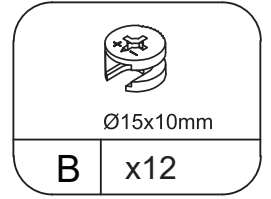
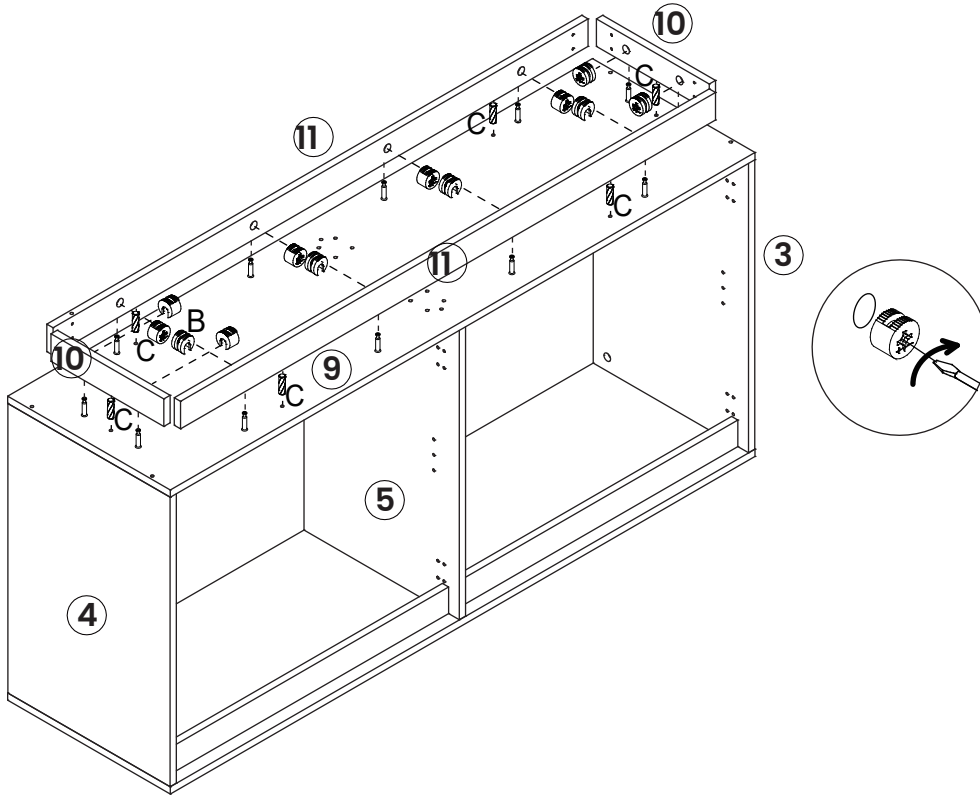

STEP 12

Please tighten the screws after completing all installation.

Por favor, apriete los tornillos después de instalar todo.

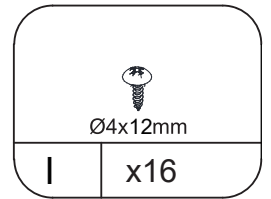
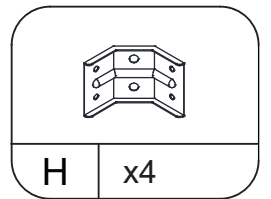
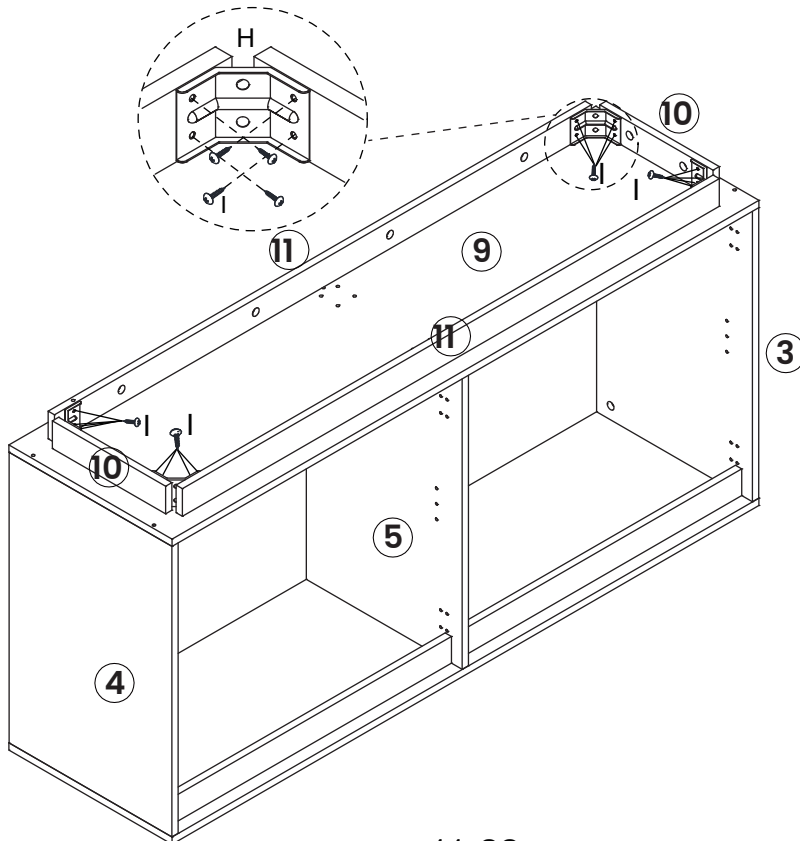

STEP 13

Please tighten the screws after completing all installation.

Por favor, apriete los tornillos después de instalar todo.

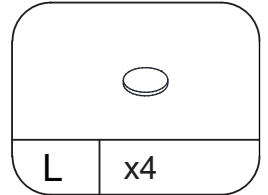
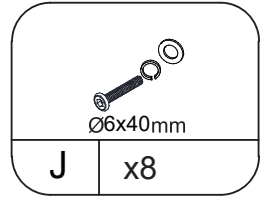
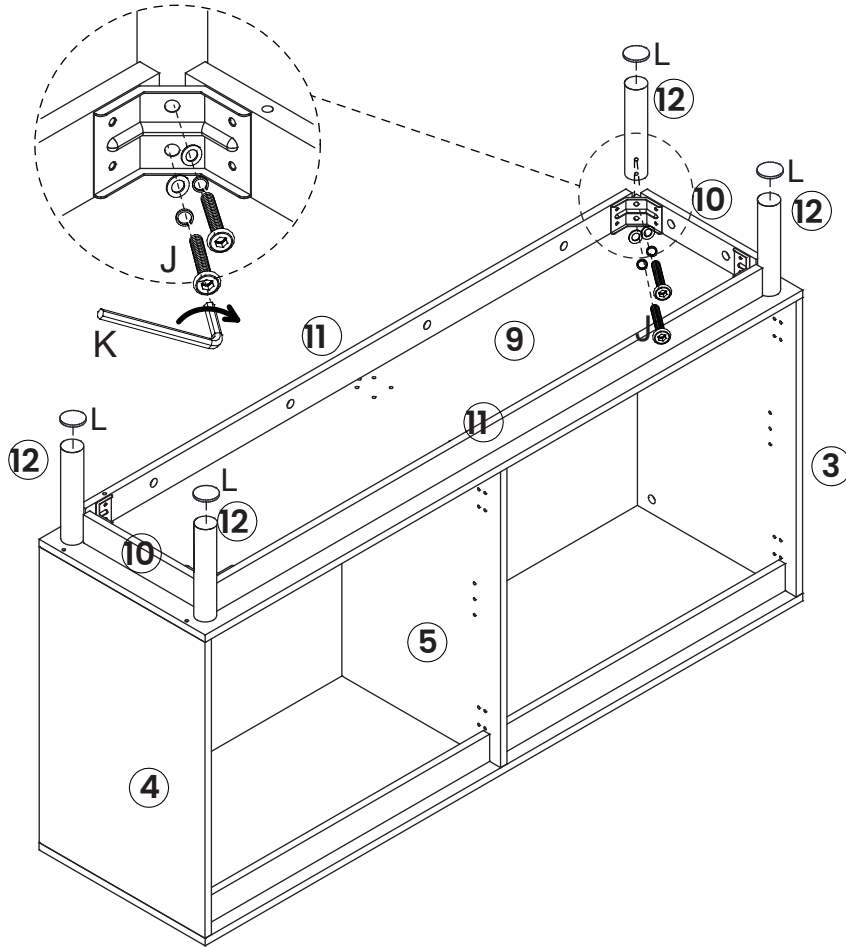

STEP 14

Please tighten the screws after completing all installation.

Por favor, apriete los tornillos después de instalar todo.

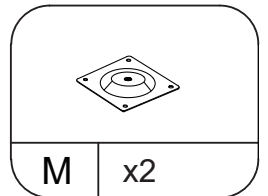
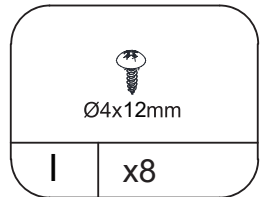
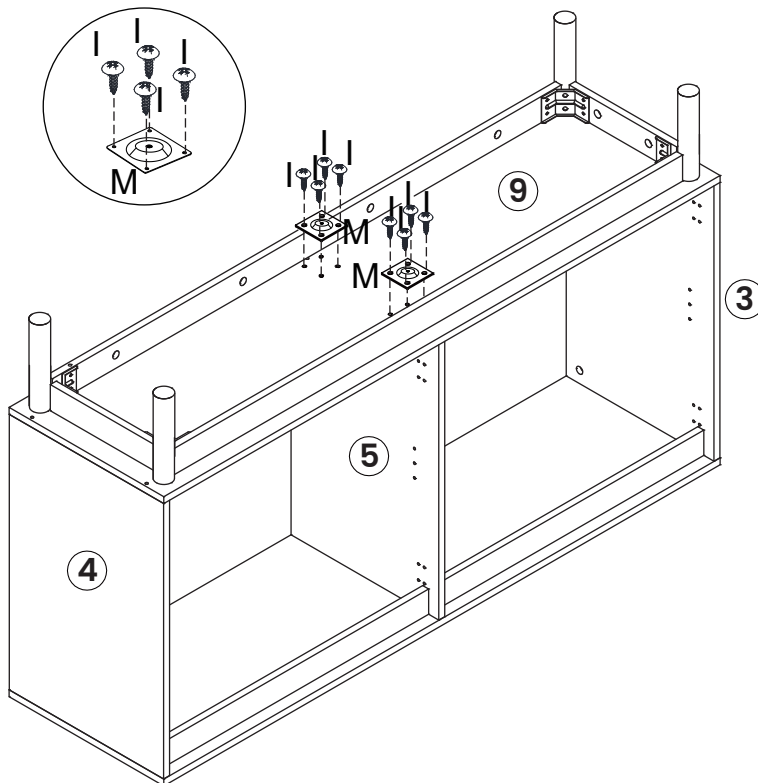

STEP 15

Please tighten the screws after completing all installation.

Por favor, apriete los tornillos después de instalar todo.

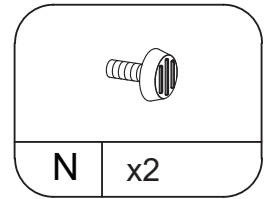
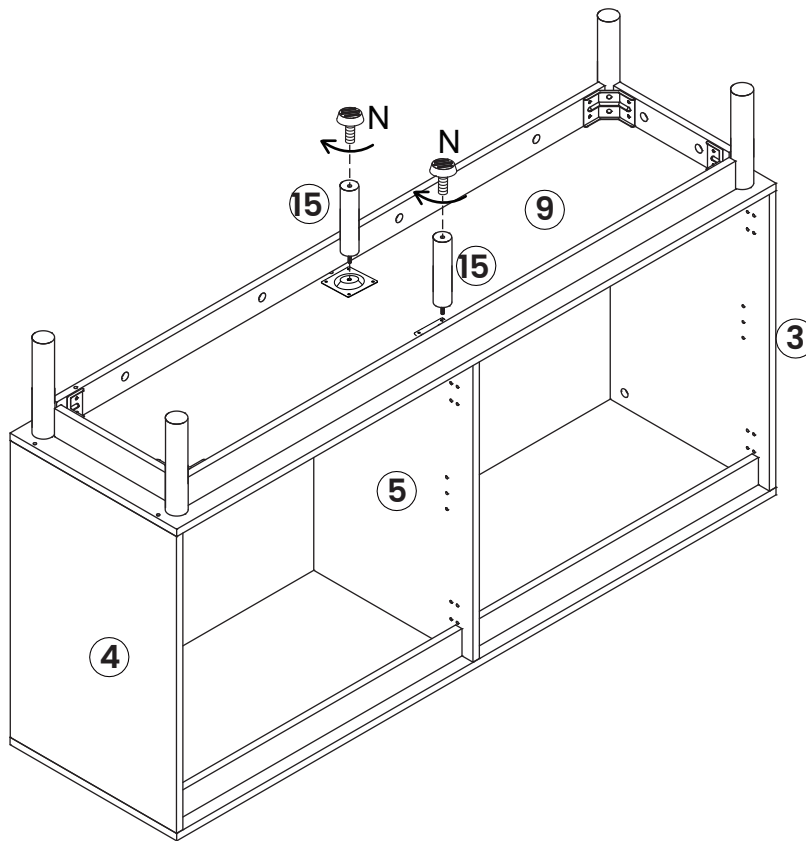

STEP 16

Please tighten the screws after completing all installation.

Por favor, apriete los tornillos después de instalar todo.

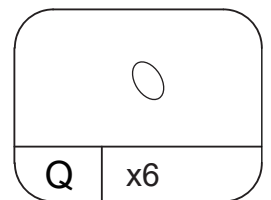
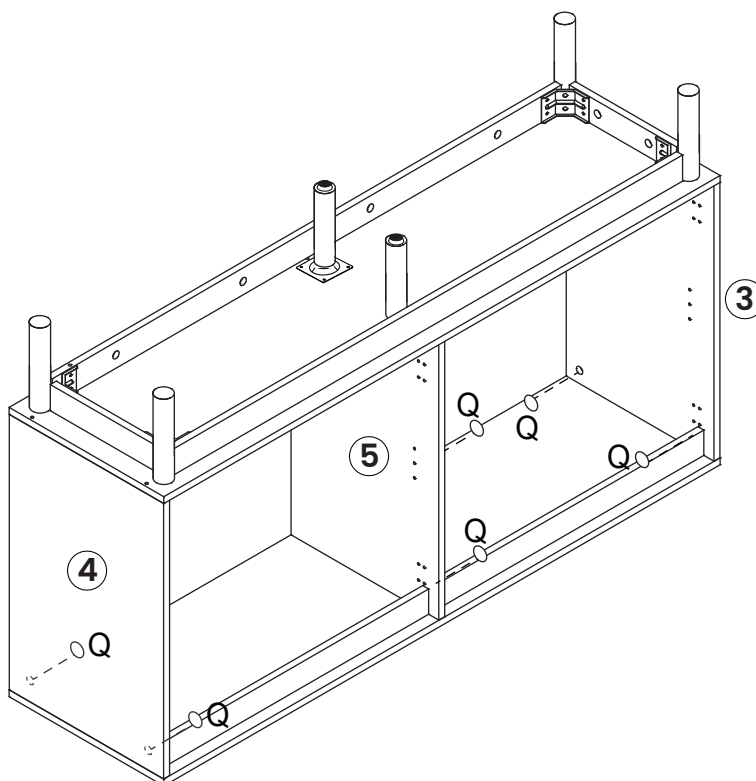

STEP 17

Please tighten the screws after completing all installation.

Por favor, apriete los tornillos después de instalar todo.

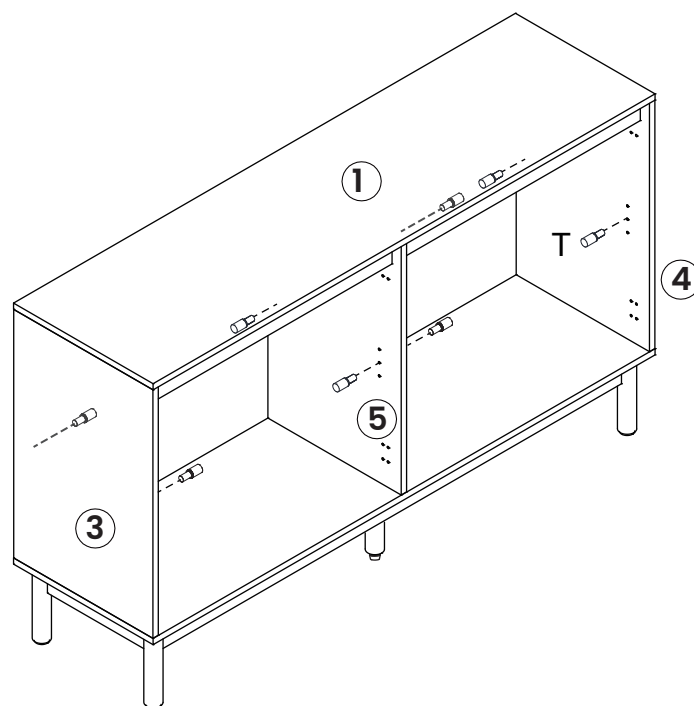
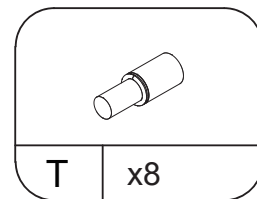

STEP 18

Please tighten the screws after completing all installation.

Por favor, apriete los tornillos después de instalar todo.

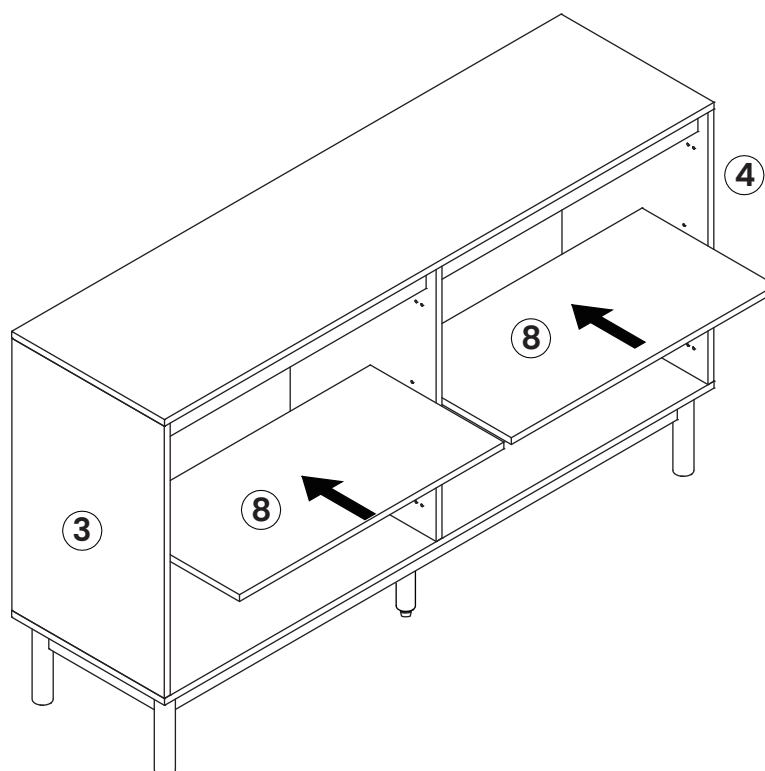

STEP 19

Please tighten the screws after completing all installation.

Por favor, apriete los tornillos después de instalar todo.

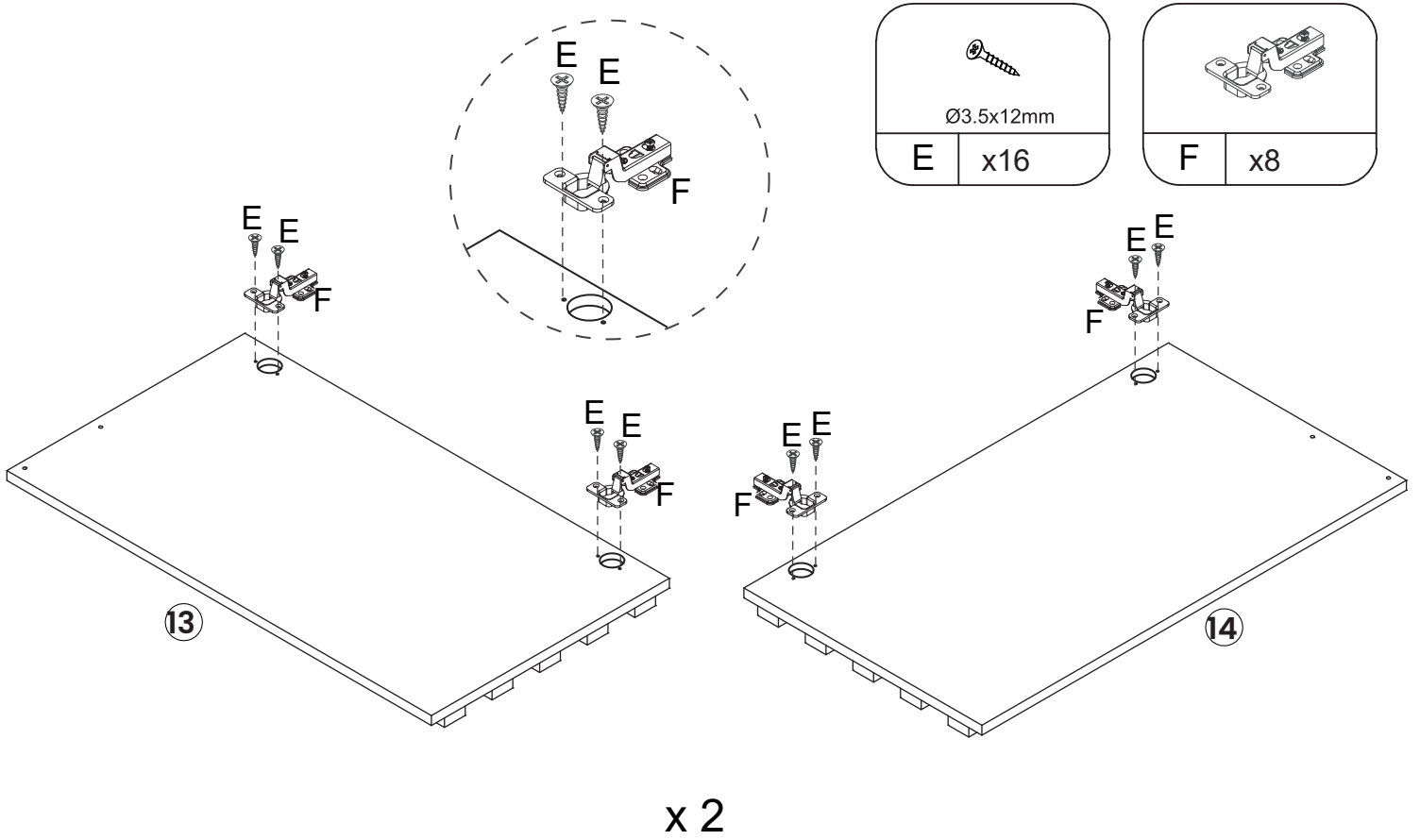

STEP 20

Please tighten the screws after completing all installation.

Por favor, apriete los tornillos después de instalar todo.

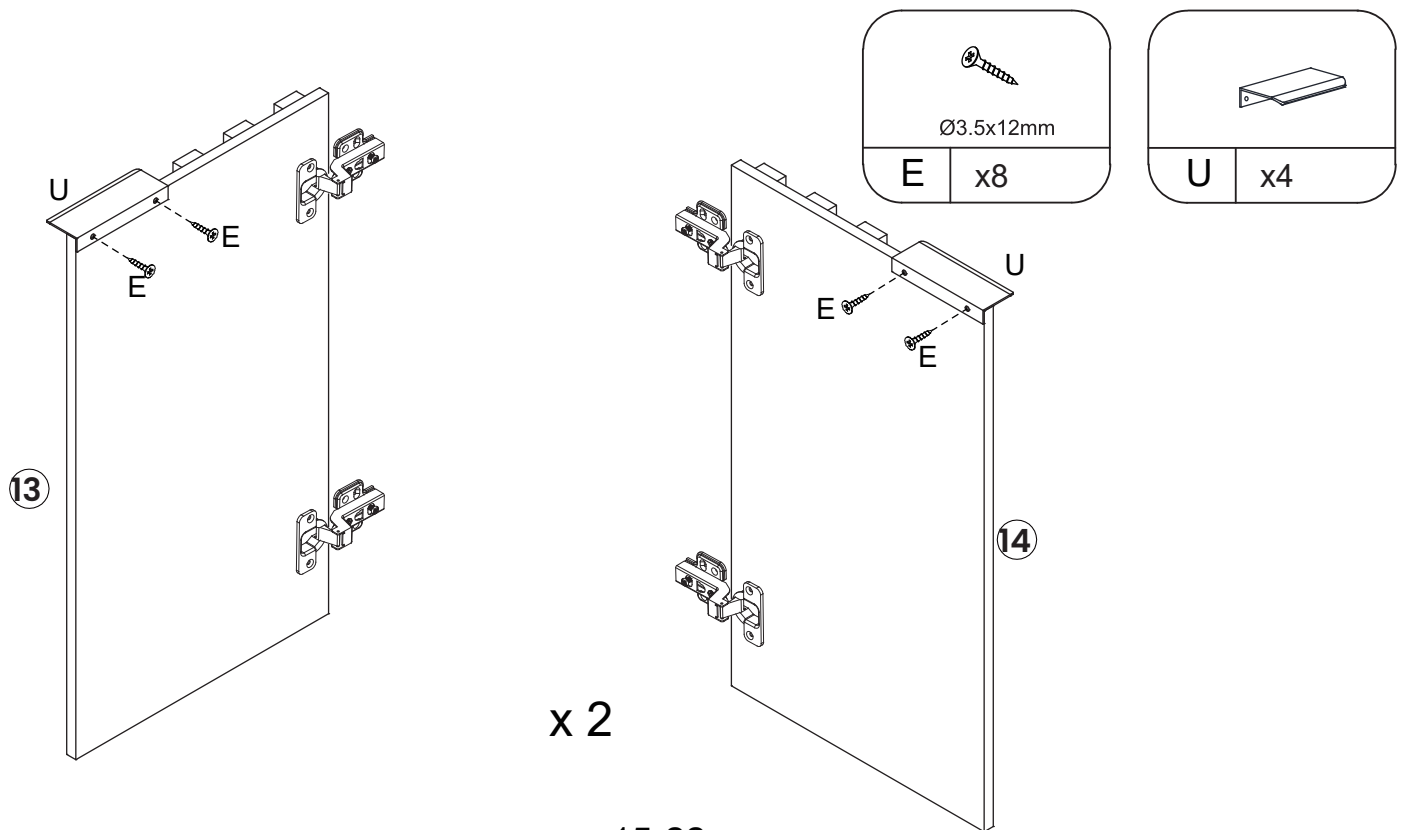

STEP 21

Please tighten the screws after completing all installation.

Por favor, apriete los tornillos después de instalar todo.

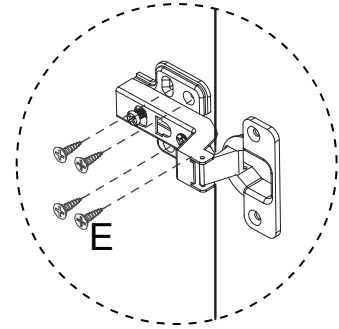
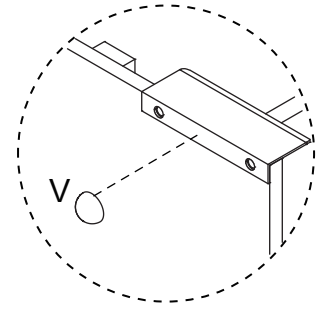
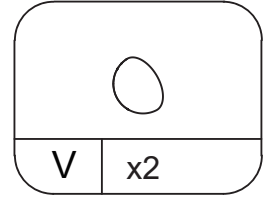
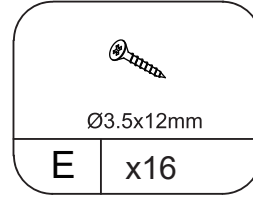
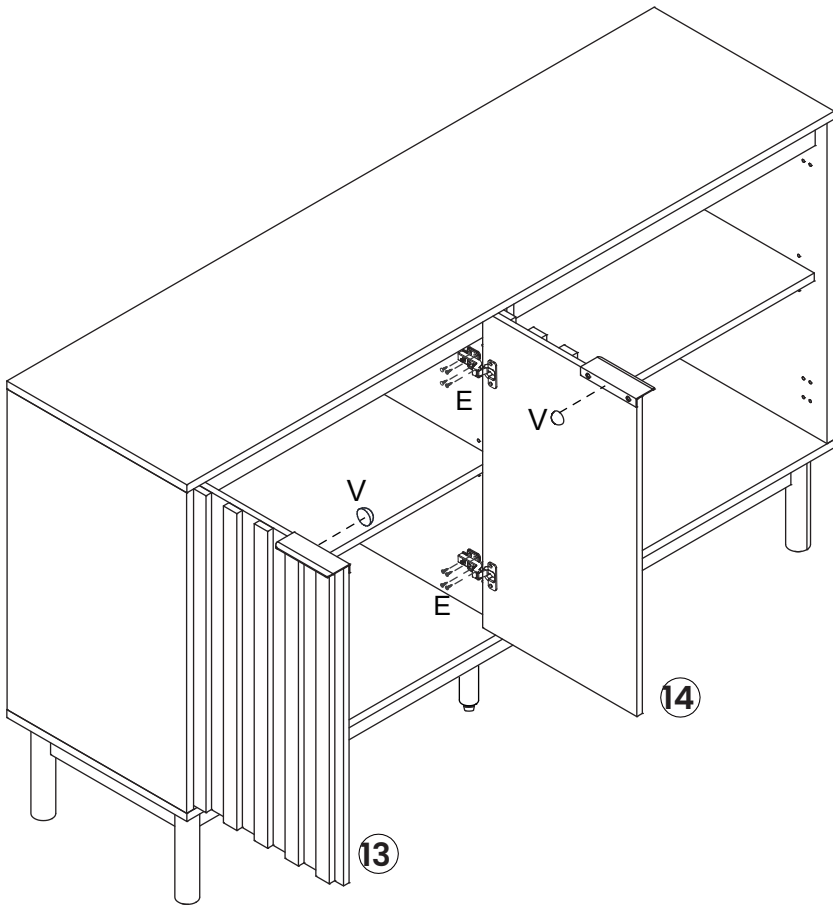

STEP 22

Please tighten the screws after completing all installation.

Por favor, apriete los tornillos después de instalar todo.

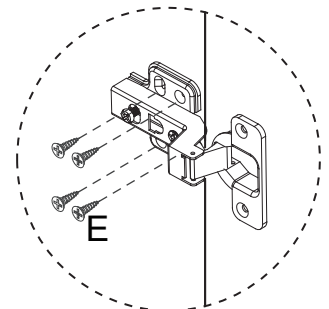
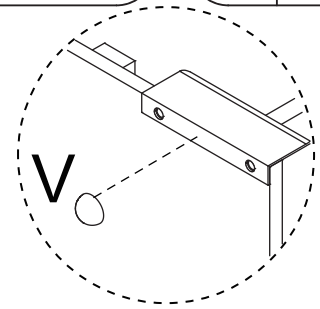
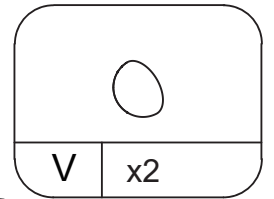
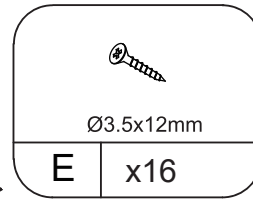
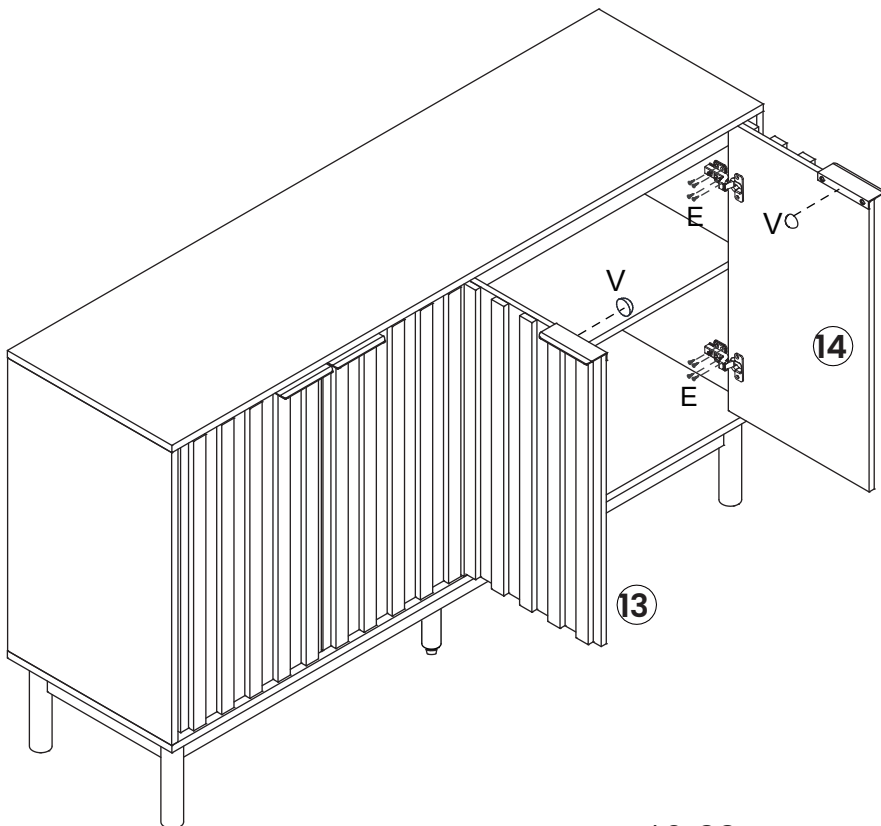

NOTE:

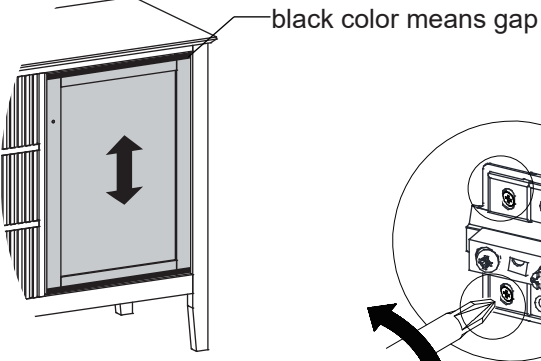

This adjustment is used if your doors have a big gap at the top or the bottom, or if one door sits straight but is lower than the other door.

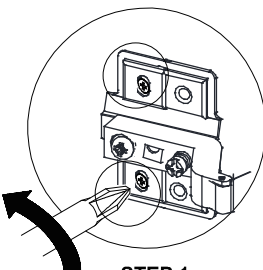

STEP 1
Please loosen the screw to adjust the door.

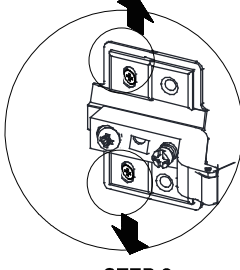

STEP 2
Adjust the door.

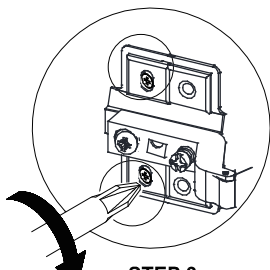

STEP 3
After adjust, tighten the screw.

Open the door and hold it. Contrarotate to loosen the screw as shown in STEP1. Gently adjust the height of the door by hand as shown in STEP2. Tighten the screws as shown in STEP3, until the heights of the two doors are the same.

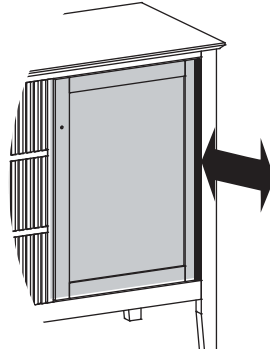

This adjustment is used if your doors are TOO CLOSE to the main cavity. You can loosen the screw and then move the door hinge closer or further out depending on the outcome you want to achieve

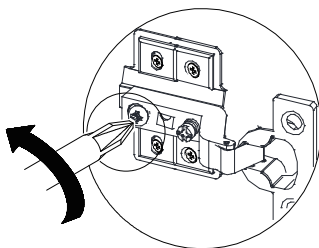

STEP 1
Please loosen the screw to adjust the door.

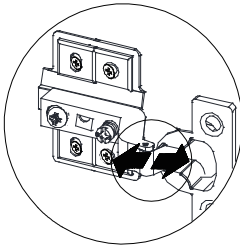

STEP 2
Adjust the door.

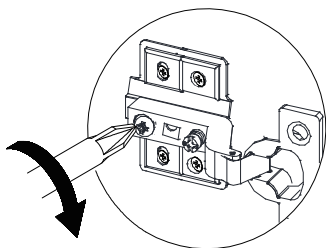

STEP 3
After adjust, tighten the screw.

Open the door and hold it. Contrarotate to loosen the screw as shown in STEP1. Gently adjust the gap between the door and body by hand as shown in STEP2. Tighten the screws as shown in STEP3, until the distances on both sides are equal.

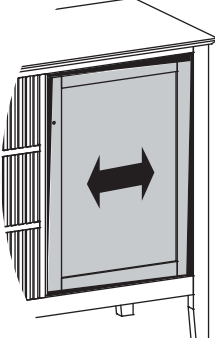

This adjustment is Used if your doors are overlapping in the middle OR there is a larger gap through the middle or on the sides

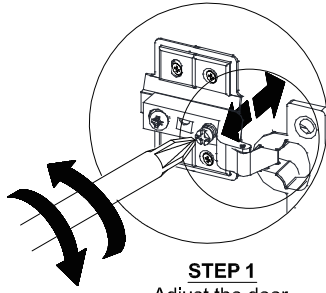

STEP 1
Adjust the door.

If the gap between the door and body is uneven, can solve the problem as shown in STEP1, by rotating the screw to adjust the door. Contrarotate the screw can move the door to left, clockwise rotate can move the door to right. Gradually adjust the door according to the actual situation, until the gap between the door and the body is even. Note that the gap of all doors on the same level should be consistent.

17-22

STEP 23

Please tighten the screws after completing all installation.

Por favor, apriete los tornillos después de instalar todo.

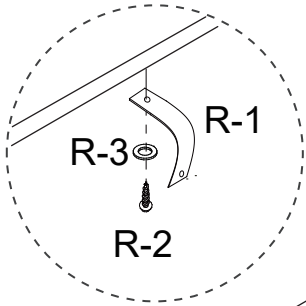

R-3
R-1
R-2

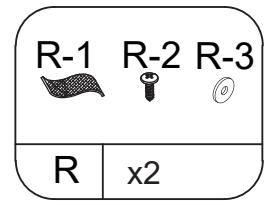
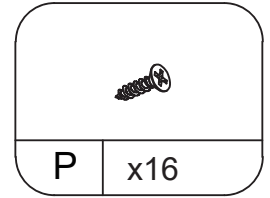
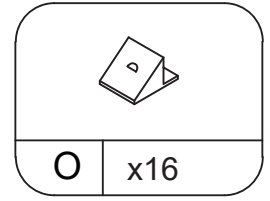
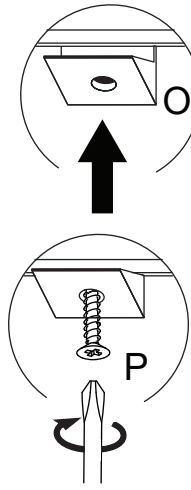
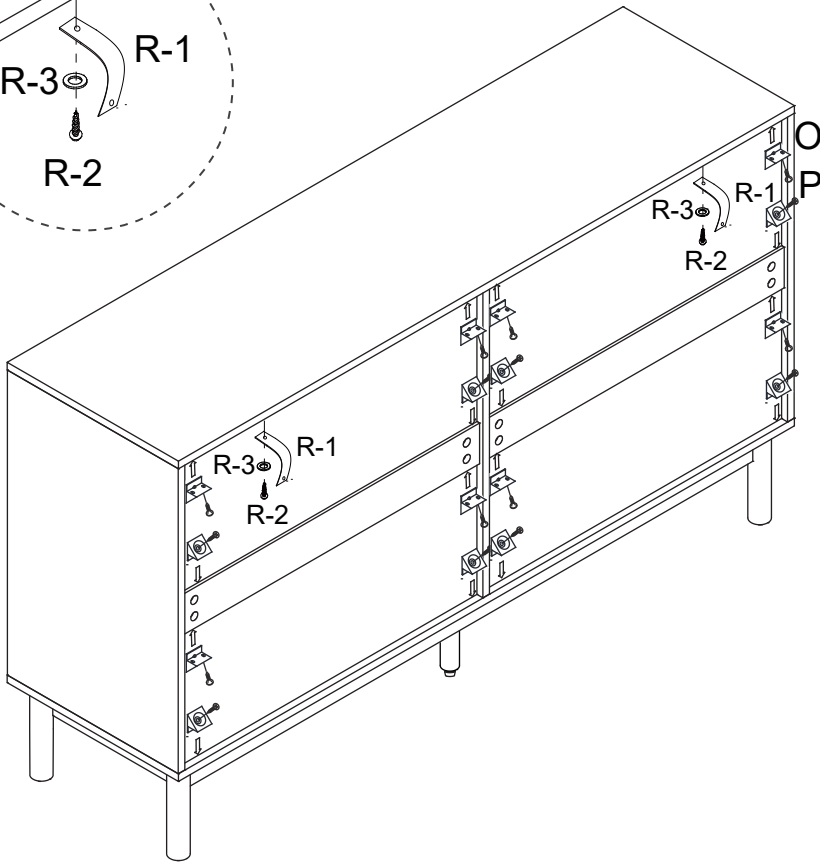

STEP 24

Please tighten the screws after completing all installation.

Por favor, apriete los tornillos después de instalar todo.

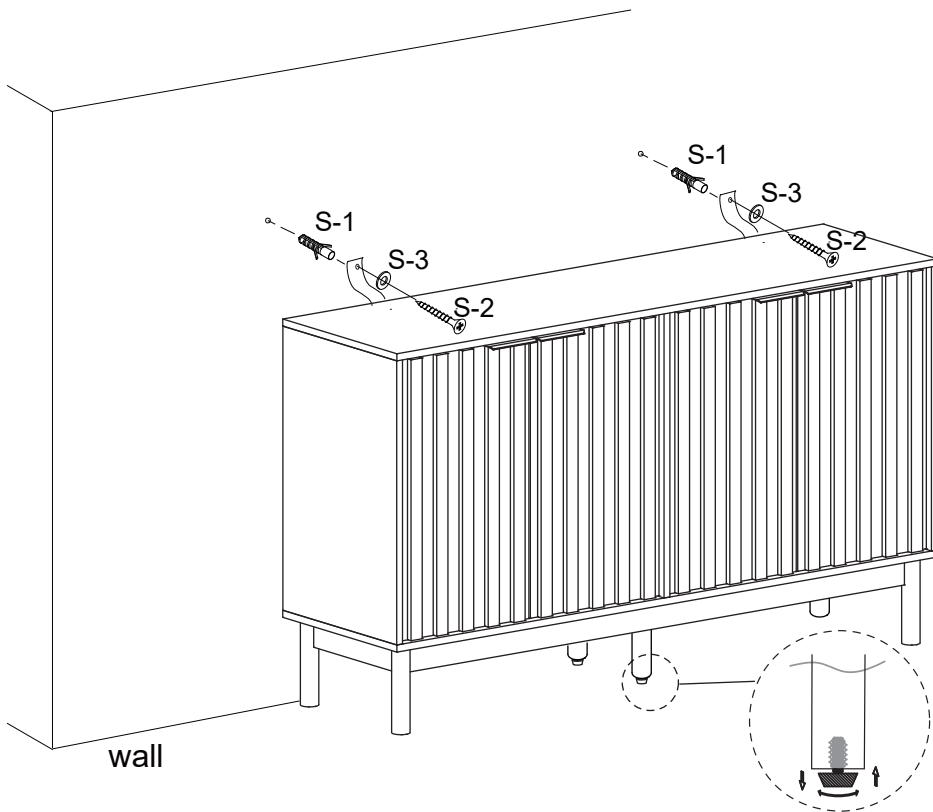

wall

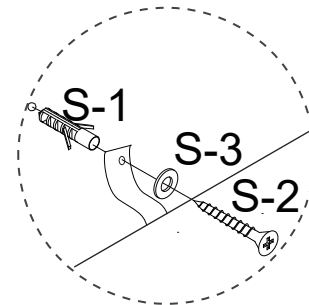
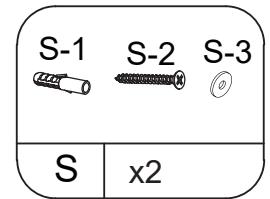



MAINTENANCE AND CARE

Prevent Moisture Damage:

Safeguard your laminate furniture by keeping it in a dry environment. Store the furniture away from damp areas and water sources.

Sunlight Shielding:

Shield your laminate furniture from direct sunlight to prevent color fading and surface deterioration. Consider using curtains or blinds for protection, especially if direct sunlight exposure is unavoidable.

Regular Care:

Maintain your laminate furniture's appearance by gently wiping surfaces with a damp cloth. Avoid using overly wet cloths or abrasive cleaning tools.

Avoid Scratches:

Protect the furniture surface from scratches by refraining from placing sharp or hard objects on it. When moving the furniture, be cautious not to scrape the legs against the floor.

Proper Weight Distribution:

Prevent structural damage by placing heavy objects on stable support surfaces rather than directly on the laminate furniture's surface. This simple step can prolong the life of your furniture.



MANTENIMIENTO Y CUIDADO

Evite daños por humedad:

Proteja sus muebles laminados manteniéndolos en un ambiente seco. Guarde los muebles lejos de zonas húmedas y fuentes de agua.

Protéjalos de la luz solar:

Proteja sus muebles laminados de la luz solar directa para evitar la pérdida de color y el deterioro de la superficie. Considere el uso de cortinas o persianas como protección, especialmente si la exposición directa a la luz solar es inevitable.

Cuidado regular:

Mantenga el aspecto de sus muebles laminados limpiando suavemente las superficies con un paño húmedo. Evite utilizar paños demasiado húmedos o herramientas de limpieza abrasivas.

Evite los arañazos:

Proteja la superficie del mueble de arañazos evitando colocar objetos afilados o duros sobre ella. Al mover el mueble, tenga cuidado de no raspar las patas contra el suelo.

Distribución adecuada del peso:

Evite daños estructurales colocando objetos pesados sobre superficies de apoyo estables en lugar de directamente sobre la superficie del mueble laminado. Este sencillo paso puede prolongar la vida de sus muebles.



WARRANTY INFORMATION

Warranty Coverage: Our warranty provides protection against manufacturing defects in materials and workmanship for a specified period from the date of purchase, as outlined in the accompanying warranty documentation.

Exclusions: The warranty does not cover damages resulting from misuse, negligence, accidents, normal wear and tear, unauthorized repairs or modifications, improper assembly, or failure to adhere to the care and maintenance guidelines provided.

WARRANTY CLAIM PROCESS

To initiate a return, please follow these steps:

1. Log into your account and go to the "Your Orders" section.
2. Locate the order containing the item you wish to return.
3. Contact our customer service for assistance in obtaining a prepaid return label.
4. Once you receive the return label, securely affix it to the package.
5. You can then choose to drop off the package at a designated carrier location or arrange for a pickup.
6. After we receive and inspect the returned product, we will initiate the refund process.
7. The refund will be credited back to the original payment method used during the purchase.
8. Typically, refunds are processed within 3-5 business days.

Cobertura de la garantía: Nuestra garantía proporciona protección contra defectos de fabricación en materiales y mano de obra durante un período determinado a partir de la fecha de compra, como se indica en la documentación de garantía adjunta.

Exclusiones: La garantía no cubre los daños resultantes de uso indebido, negligencia, accidentes, desgaste normal, reparaciones o modificaciones no autorizadas, montaje incorrecto o incumplimiento de las directrices de cuidado y mantenimiento proporcionadas. Las directrices de cuidado y mantenimiento proporcionadas.

PROCESO DE RECLAMACIÓN DE LA GARANTÍA

Para iniciar una devolución, siga estos pasos:

1. Accede a tu cuenta y ve a la sección "Tus pedidos".
2. Localiza el pedido que contiene el artículo que deseas devolver.
3. Ponte en contacto con nuestro servicio de atención al cliente para que te ayuden a obtener una etiqueta de devolución prepagada.
4. Una vez que reciba la etiqueta de devolución, fíjela firmemente al paquete.
5. A continuación, puede optar por depositar el paquete en el lugar designado por el transportista o solicitar que lo recojan.
6. Después de que recibamos e inspeccionemos el producto devuelto, iniciaremos el proceso de reembolso.
7. El reembolso se abonará de nuevo al método de pago original utilizado durante la compra.
8. Normalmente, los reembolsos se procesan en un plazo de 3 a 5 días laborables.