

# QUEEN & FULL UNIVERSAL SIZE HEADBOARD ONLY

## ASSEMBLY INSTRUCTION



# ASSEMBLY INSTRUCTIONS

**ASSEMBLY TIPS:**

1. Remove hardware from box and sort by size.
2. Please check to see that all hardware and parts are present prior start to of assembly.
3. Please follow attached instructions in the same sequence as numbered to assure fast & easy assembly.









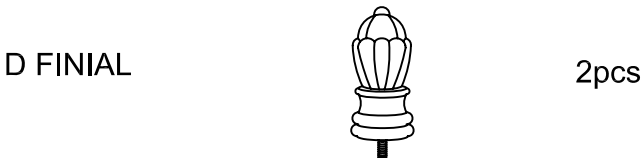
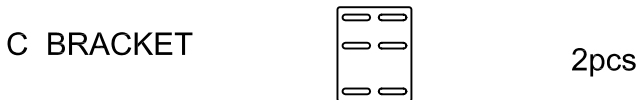
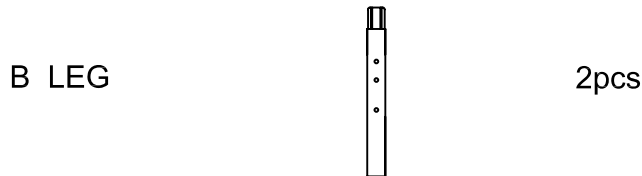
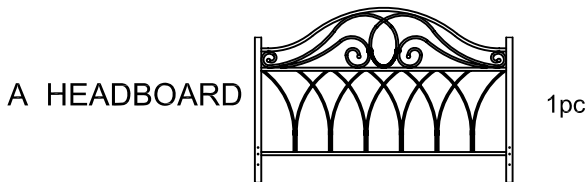

**Warning !**

1. Don't attempt to repair modify parts that are broken or defective . Please contact the store immediately.
2. This product is for home use only and not intended for commercial establishment.

**PARTS IDENTIFICATION**

**Z HARDWARE PACKAGE**



NO	DESCRIPTION	FIGURE	Q`TY
1	BOLT 1/4"x2 <sup>3</sup> / <sub>4</sub> "		4pcs
2	BOLT 1/4"x7/8"		4pcs
3	SMALL WASHER		12pcs
4	LARGE WASHER		8pcs
5	BOLT		8pcs
6	CAP		2pcs
7	ALLEN WRENCH		1pc
8	OPEN WRENCH		1pc

60" ASSEMBLY INSTRUCTIONS

**STEP 1:** Insert the finial (D) into each of the pre-drilled holes, tighten anticlockwise it, and then locate the leg (B), using bolt (1,5), washer (3,4) through the pre-drilled holes to attach the baseframe to headboard.

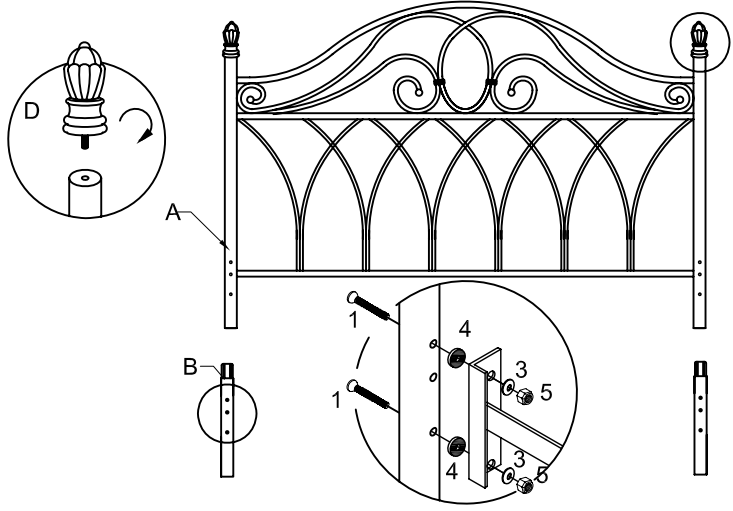

54" ASSEMBLY INSTRUCTIONS

**STEP 2:** Insert the finial (D) into each of the pre-drilled holes, tighten anticlockwise it, and then locate the bracket (C) and leg (B), using bolt (1,2,5), washer (3,4) to attach it to the headboard, and it can be adjusted to be 54" bed.

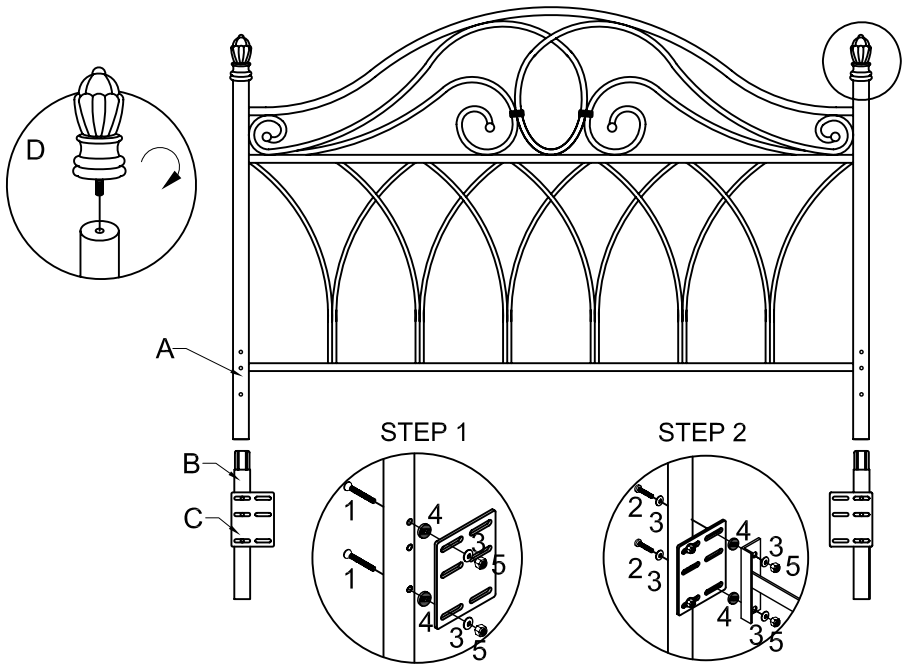

STEP 3: Push the cap(6) the end of the post of headboard, and using bolt(1,5), washer(3,4) to attach baseframe to headboard.

