

Instruction Manual

A (mm)	B (mm)	R (mm)	A (mm)	B (mm)	R (mm)
590	410	20	662	410	15

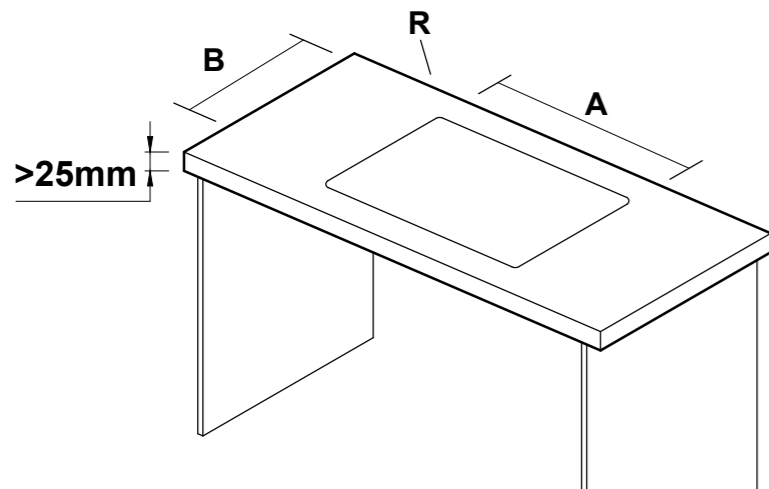

1

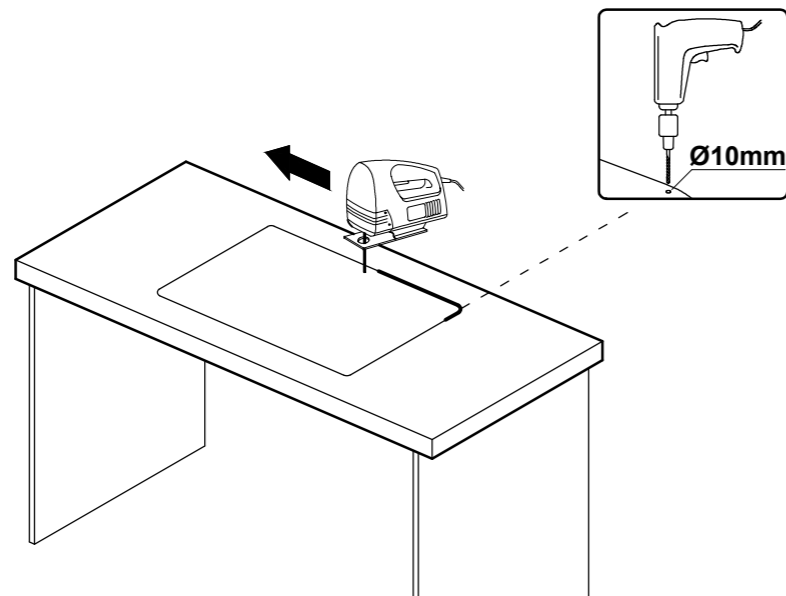

2

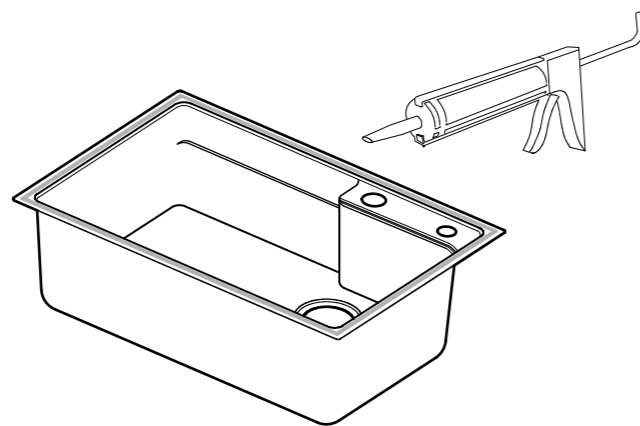

3

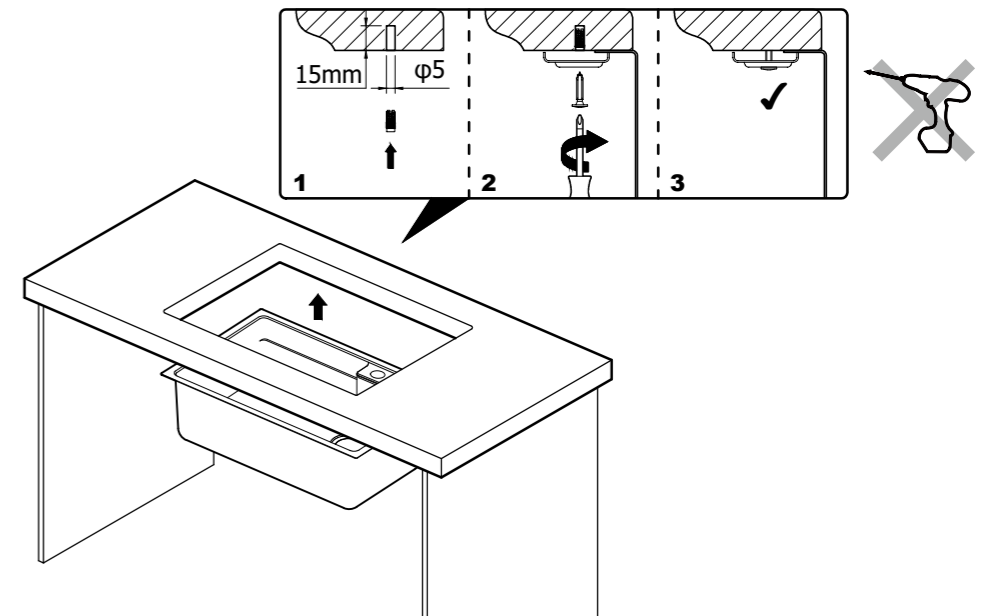

4

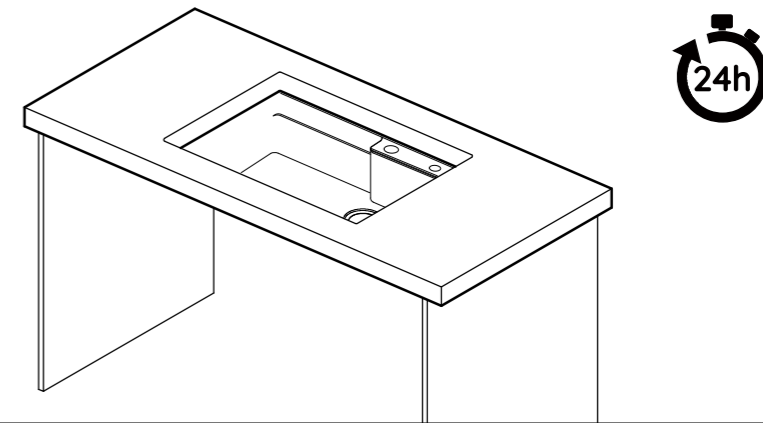

SINK MAINTENANCE TIPS – STAINLESS STEEL SINKS

- By following these maintenance tips, you can maintain the finish of your stainless steel sink for longer.
- Scratching on the surface of sinks will occur over time through normal usage. Scratches cannot be removed only made less noticeable by using stainless steel polishing creams and cleaning products. The best form of maintenance is frequent, regular cleaning. A little bit of cleaning on a regular basis is preferable to a major clean on a sporadic basis.
- The best method of preventative maintenance is to ensure the sink is clean and dry. Rinse and towel dry the sink after each use in order to minimise major cleaning, keeping it shiny and relatively free of water spots.
- Keep the sink free of any standing water, which may build up mineral deposits. The quality of your water can affect the sinks appearance and this water quality will vary from household to household.
- To clean your sink use the mildest cleaning procedure that will do the job effectively. Exercise extreme care with household cleaners in particular detergents or bleaches.
- Always rinse the sink after using a cleaning agent and wipe the sink dry to discourage water spotting.
- Metallic scouring pads and steel wool pads should not be used to clean your sink or any utensils in the sink. They will not only scratch the sink but also leave a residue of small iron particles, these may not be visible but they will most certainly lead to rusting and corrosion on the sink surface.
- Do not leave any mild steel, cast iron cookware or implements anywhere on the sink for extended periods of time. The combined presence of iron and moisture with stainless steel leads to surface corrosion and sink staining.
- Do not leave wet sponges or cleaning pads in the sink overnight as they will trap water which could lead to staining or discolouration of the sink surface. The unique properties of stainless steel are dependent upon exposure of the surface to the atmosphere.
- We recommend that you do not use chlorine bleach in your stainless steel sink, as chlorine will attack the protective layer that makes stainless steel truly stainless. Any drain cleaning products containing sulphuric or hydrochloric acid will also attack the sink.
- For the occasional treatment of grime and mineral deposits that may build up over time, use cleaning products specifically designed for stainless steel following the manufacturer's instructions.
- If rusting or spotting occurs it can easily be removed with the use of a cutting compound, a soft scrubber (such as nylon or plastic) and a little elbow grease.
- In conformity with (EC) 1935/2004.

STAINLESS STEEL SINK PRODUCT CARE AND CLEANING INSTRUCTIONS

- Always wipe the sink down with warm soapy water and a cloth. This will remove general everyday stains from your sink.
- In hard water areas limescale deposits can build up on the sink over time. The limescale can become strongly coloured by such foods as coffee and red wine etc, we recommend the use of lemon juice or vinegar to remove this. Simply apply, leave for a few minutes and rinse away with water.
- If stains become ingrained in the bowl, an overnight soak using diluted biological washing powder should remove the marks easily. Ensure you thoroughly rinse the sink with water afterwards.
- For further advice on cleaning products please contact our Customer Service team.
- We recommend the use of baskets, grids and chopping boards to help reduce the risk of accidental damage.
- You must not pour strong chemicals down the sink such as bleach, ammonia, caustic soda, white spirit and sterilising solutions. If this should accidentally happen, quickly wipe the spill away and rinse with plenty of water.
- We do not recommend the use of a plastic washing up bowl, as particles of grit which may be impregnated in the base of the bowl could scratch surface of the sink.
- Do not chop food directly on the sink surface, as this will cause damage. Wooden chopping boards are available for this purpose.
- Avoid dropping sharp objects into the sink, as this may scratch or damage the surface.
- Leaving neat bleach in the sink can cause damage to all sinks even stainless steel. If neat bleach should come into contact with this product, please rinse thoroughly with warm soapy water.