

## Menta C100.000

### Features



- Vanity Base Unit
- Available in 3 Finishes: Natural Oak, Grey Pine, and Wenge
- Wall-hung design offers a clean, streamlined look
- Two soft close drawers with organizer in upper drawer
- Hettich sliding system
- Fully assembled
- Structure and front made of engineered wood in wood finishes and high gloss lacquered
- Handle integrated in front of furniture
- Does not include vanity top or sink
- Made in Spain



### SKU# | Options:

- Menta C100.000 GP | Grey Pine
- Menta C100.000 NO | Natural Oak
- Menta C100.000 WE | Wenge

### Finishes:

-  Grey Pine
-  Natural Oak
-  Wenge

### Codes & Standards:

- CARB2 Compliant and Certified; TSCA Compliant and Certified

\* WS Bath Collections reserves the right to revise dimensions or information on this sheet without notice

<b>Collection  </b> Menta	<b>Model  </b> Menta C100.000	<b>Dimensions Metric</b>  <i>1 inch = 2.54 cm</i> <i>1 inch = 25.4 mm</i>	 1051 Lea Drive - Collegeville, PA 19426 Tel. 215 513 9400 - Fax 610 831 0215 <a href="http://www.ws bathcollections.com">www.ws bathcollections.com</a> - <a href="mailto:info@ws bathcollections.com">info@ws bathcollections.com</a>
------------------------------	----------------------------------	--	---

## Menta C100

### Sink

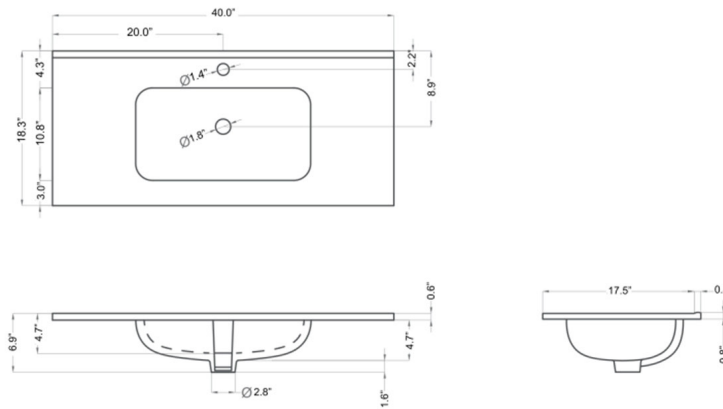

### Base Unit

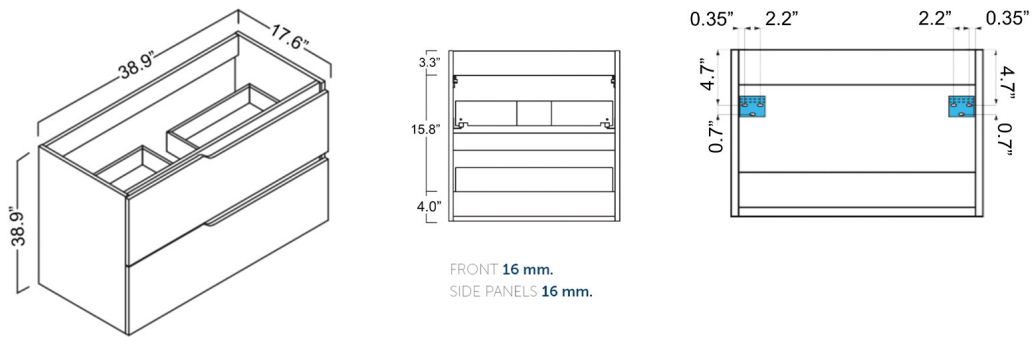

#### Technical information



Soft close.



Hettich sliding system.



Glossy lacquered finish.

**Collection |**  
Menta

**Model |**  
Menta C100

**Dimensions Metric**  
1 inch = 2.54 cm  
1 inch = 25.4 mm

**WS<sup>®</sup>**  
**BATH**  
**COLLECTIONS**

1051 Lea Drive - Collegeville, PA 19426  
Tel. 215 513 9400 - Fax 610 831 0215

[www.ws bathcollections.com](http://www.ws bathcollections.com) - [info@ws bathcollections.com](mailto:info@ws bathcollections.com)