

# Not For Nothing Shelf

DESIGNED IN 2021

ASSEMBLY NOTES | REV 00

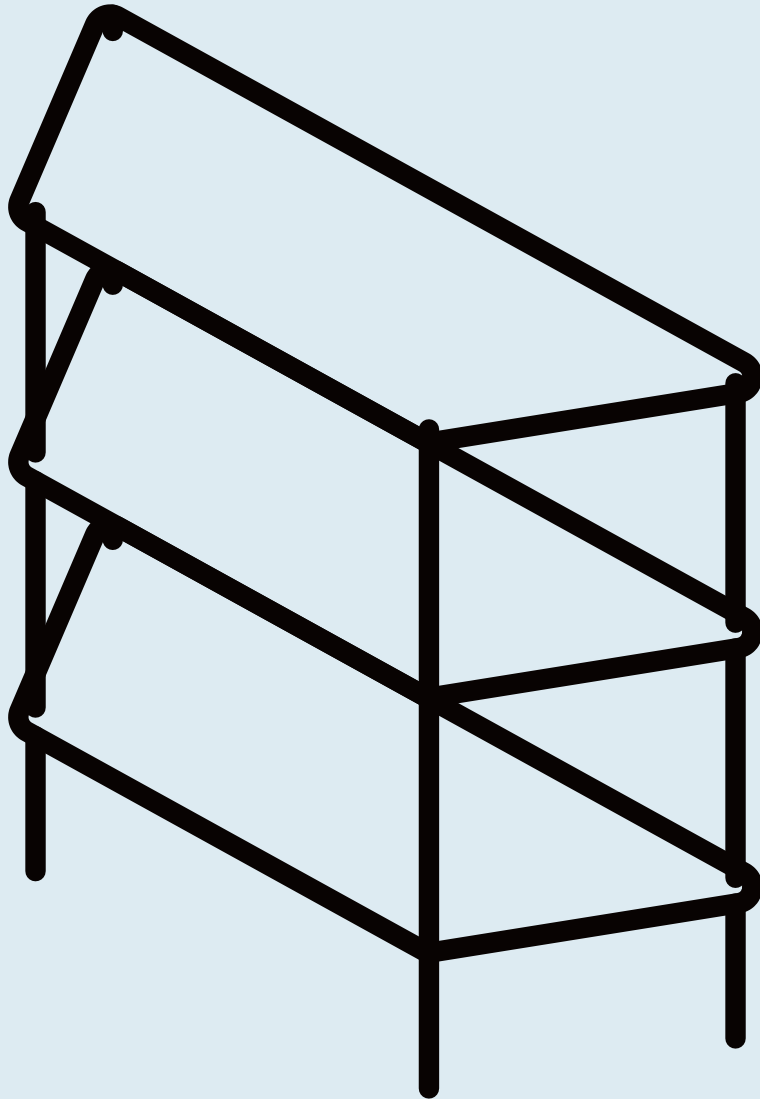
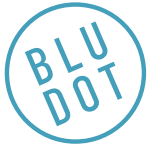

## NEED A HAND?

Contact us at [service@bludot.com](mailto:service@bludot.com) or **844.425.8368** for assistance.

## @BLUDOT

We design all our pieces in our Minneapolis studio. Follow along on Instagram for some sneak peeks into the process.

# Parts & Hardware

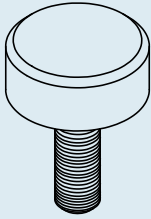

QTY

4\*

Top Cap

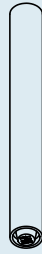

QTY

4\*

Leg



QTY

8\*

Upright

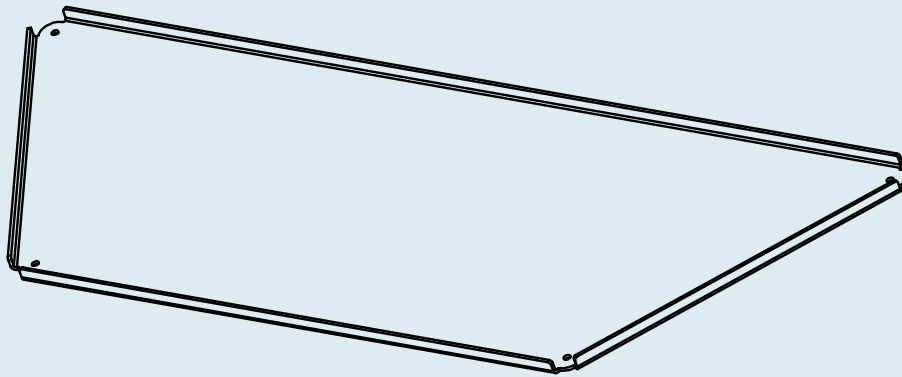

QTY

3

Shelf\*

\*The Small Shelf has three legs and six uprights along with a triangle shaped shelf.

# Step 01

## ASSEMBLING THE TOP SHELF.

Install the uprights by inserting the top cap through the shelf, then loosely twisting the upright to the top cap.

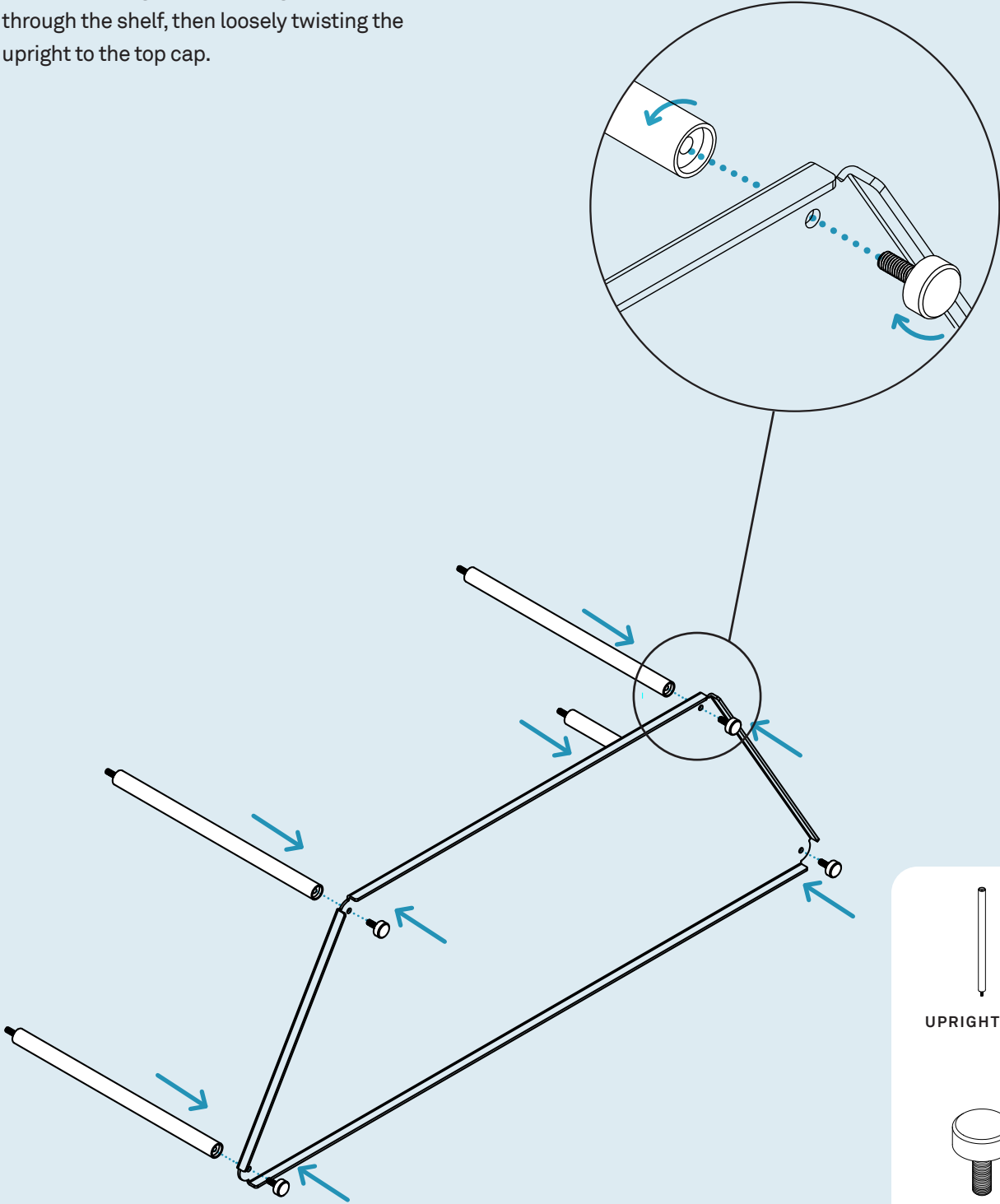

UPRIGHT X 4\*

TOP CAP X 4\*

## Step 02

### ATTACHING THE MIDDLE SHELF.

Install the middle shelf by, first, inserting the uprights from step one into the shelf, then loosely twist on the second set of uprights.

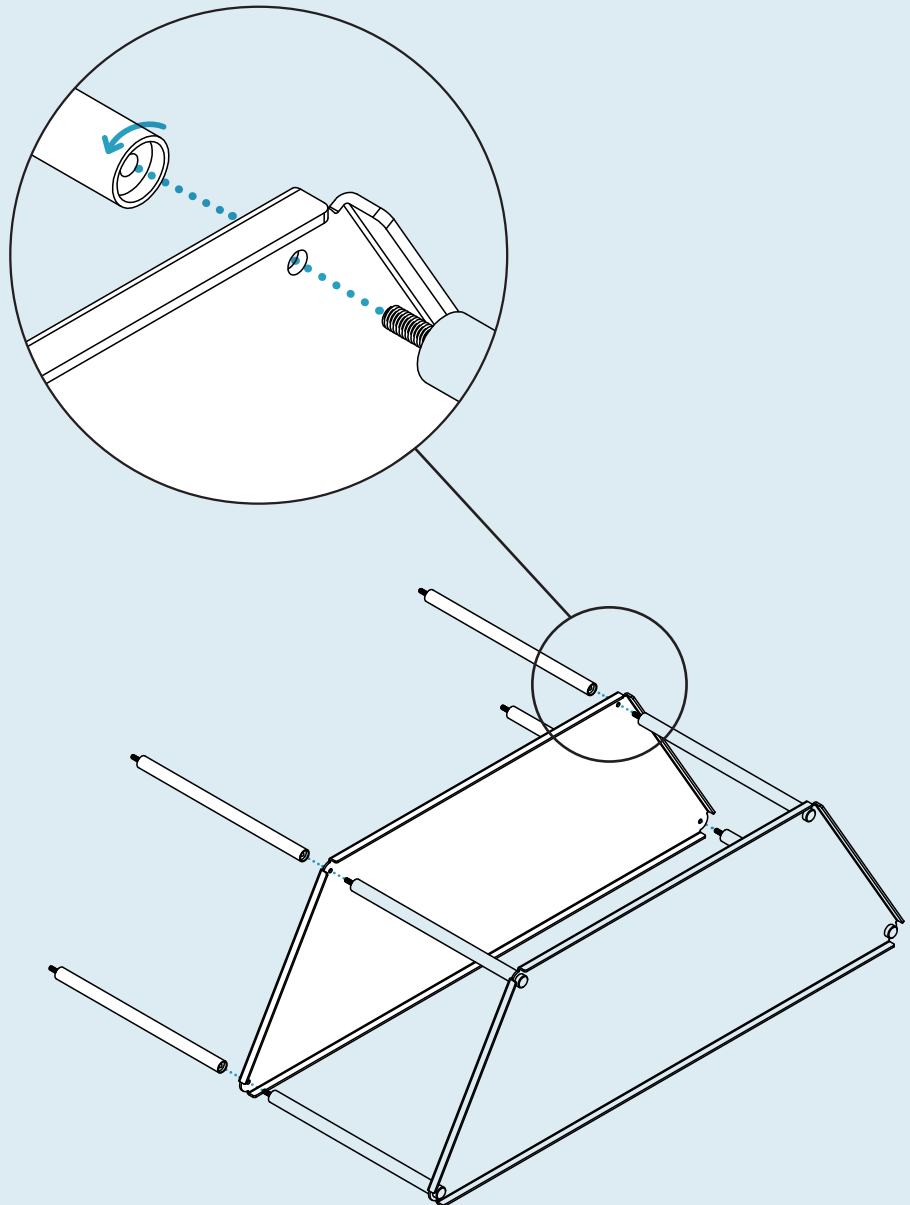

UPRIGHT x 4\*

# Step 03

## ATTACHING THE BOTTOM SHELF AND LEGS.

Install the bottom shelf by, first, inserting the uprights from step two into the shelf, then loosely twist on the legs at each of the corners.

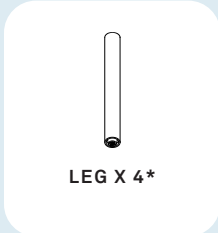
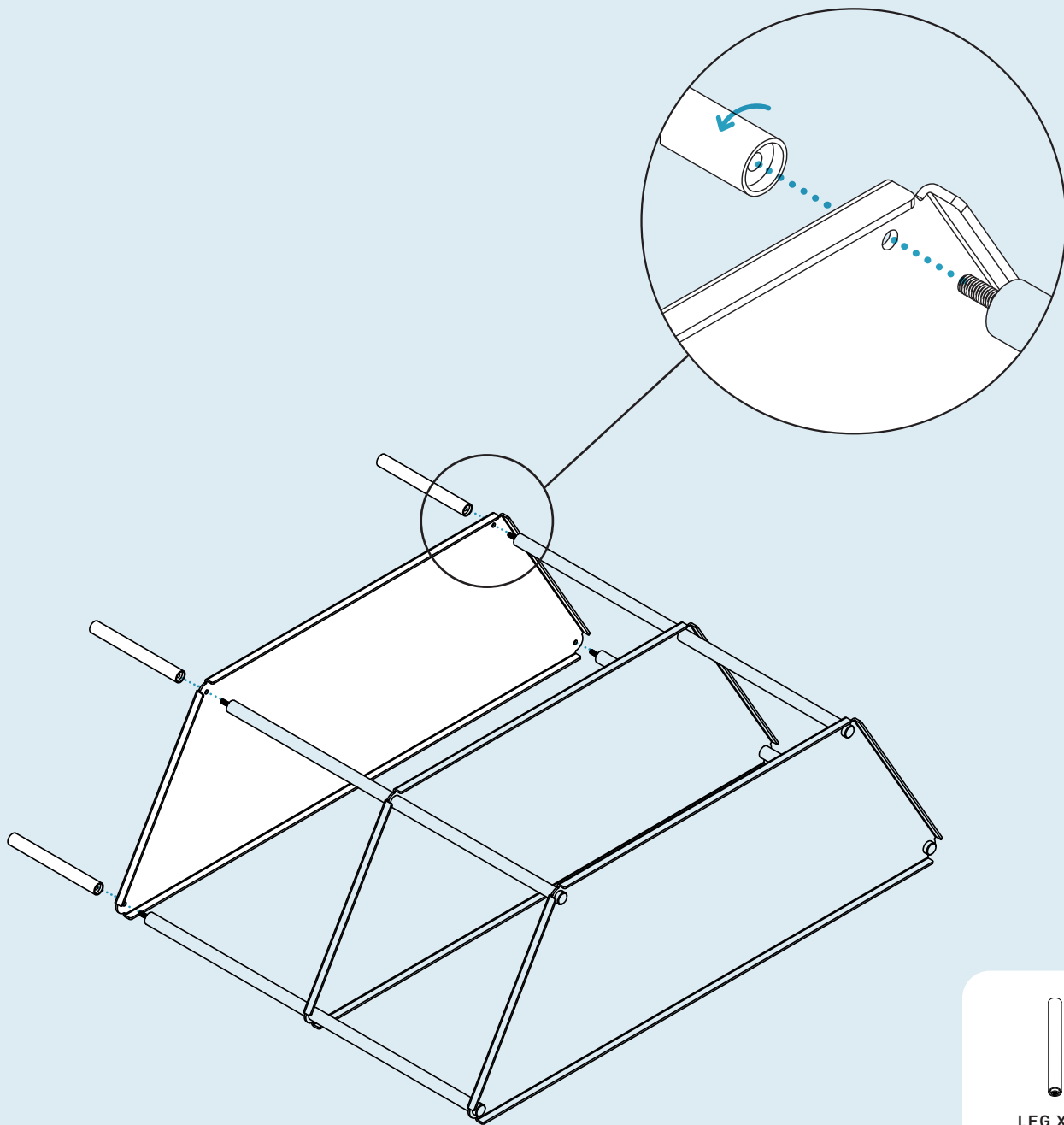

# Step 04

## TIGHTEN AND LEVEL.

Stand the shelves upright.  
Tighten the uprights, then the legs, working from the top down. If shelf is wobbly adjust the glides on the bottom of each leg until sturdy.

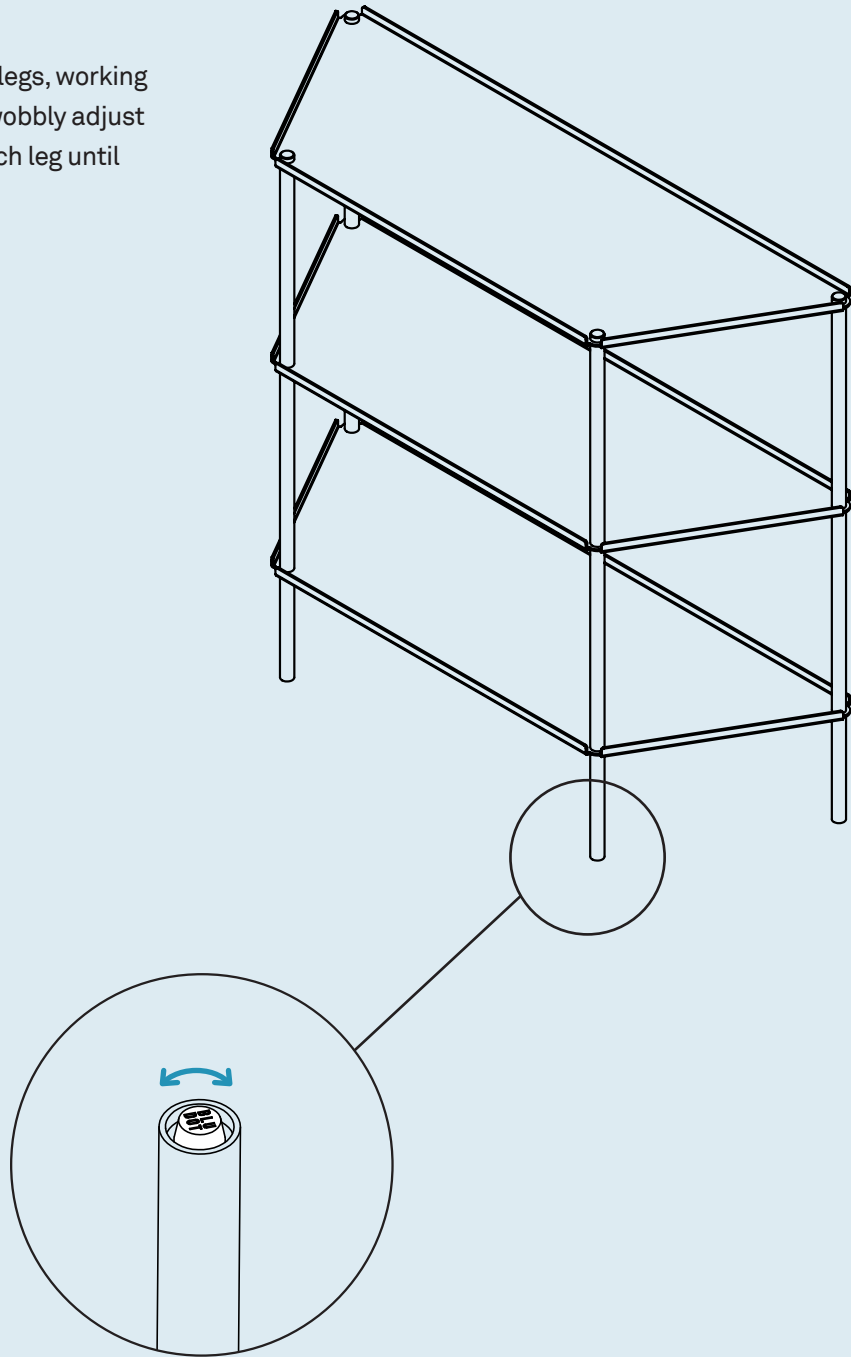

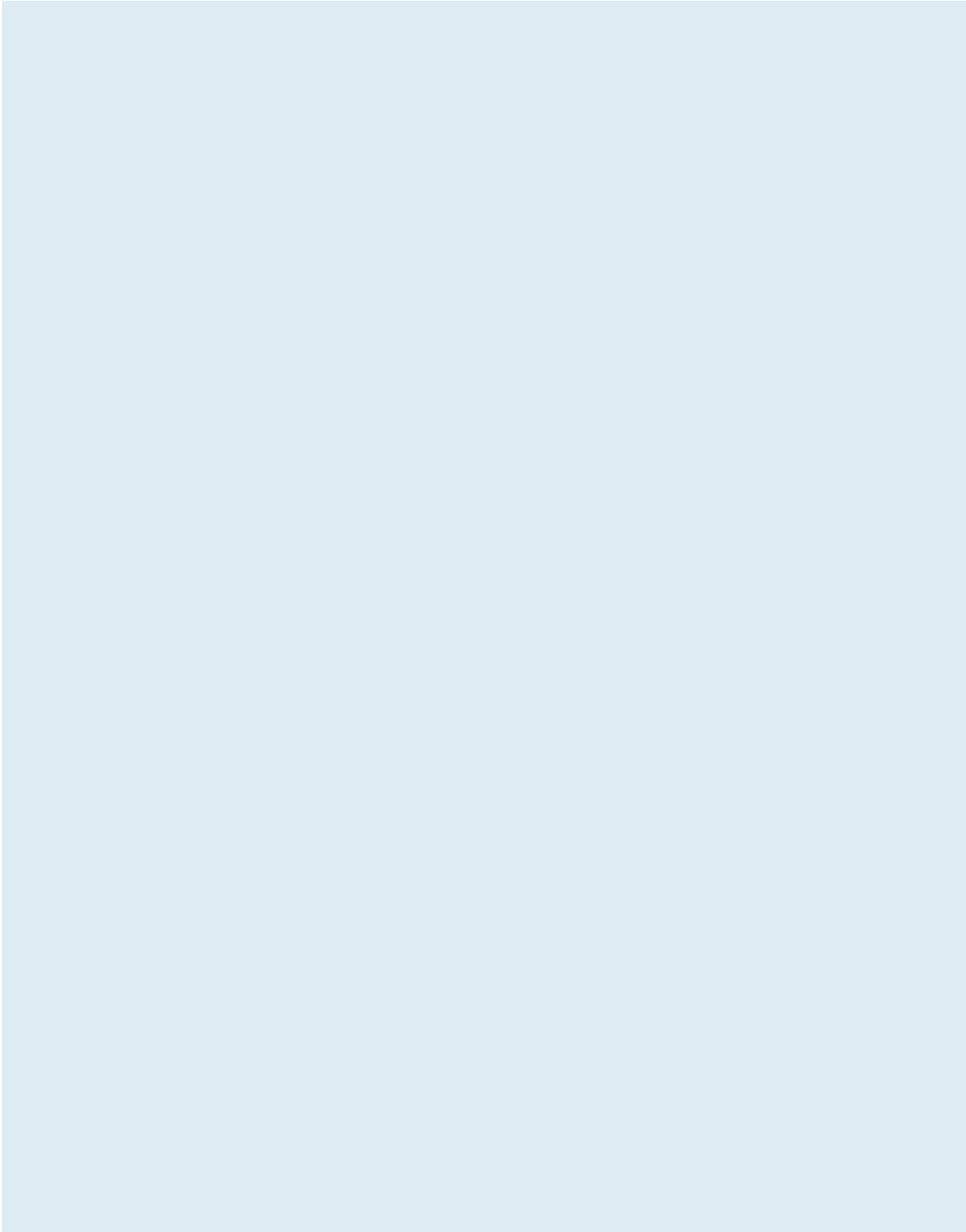

## Additional Information

### CLEAN

Clean with a slightly damp, soft cloth. To remove dirt and fingerprints, use a quality cleaner formulated for metal furniture. Wipe completely dry with a soft cloth.

