

tea table

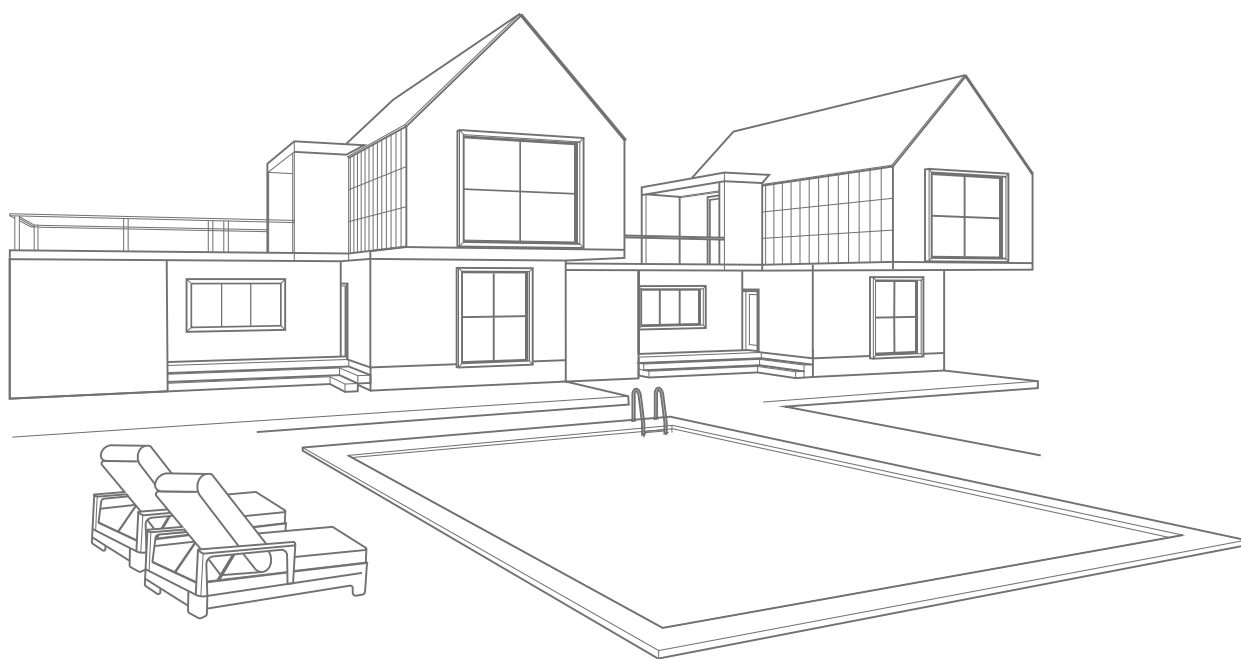

INSTALLATION MANUAL

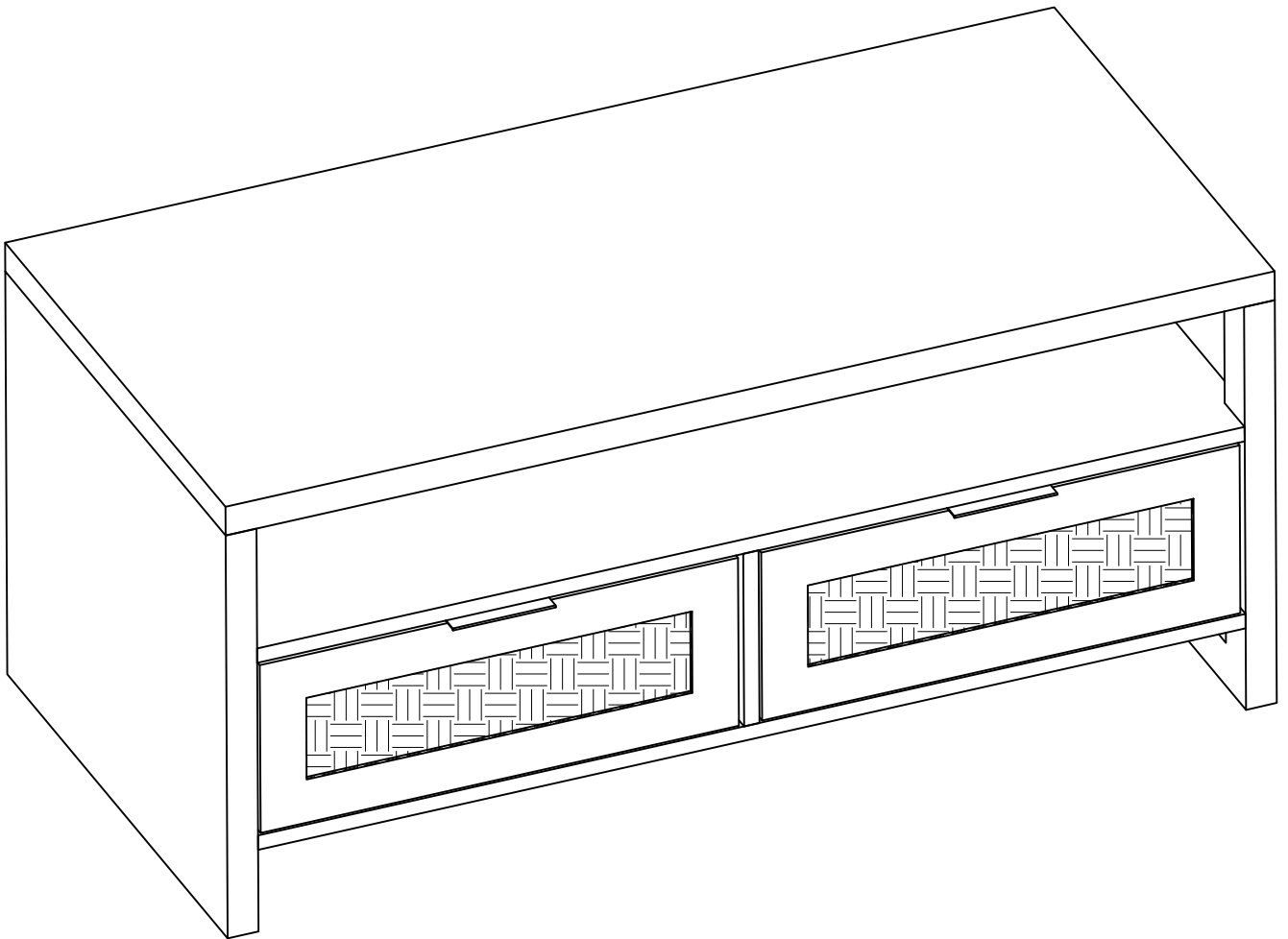

Exploded View

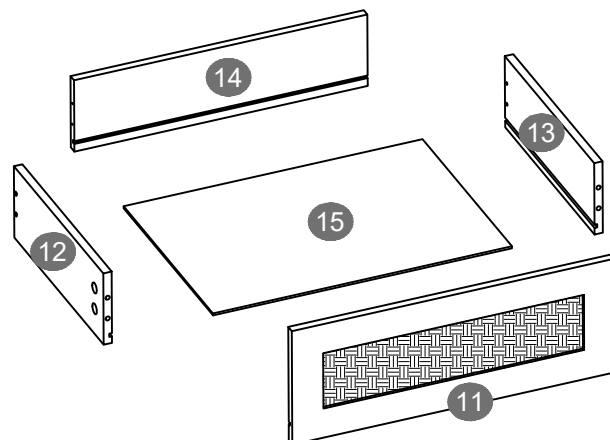
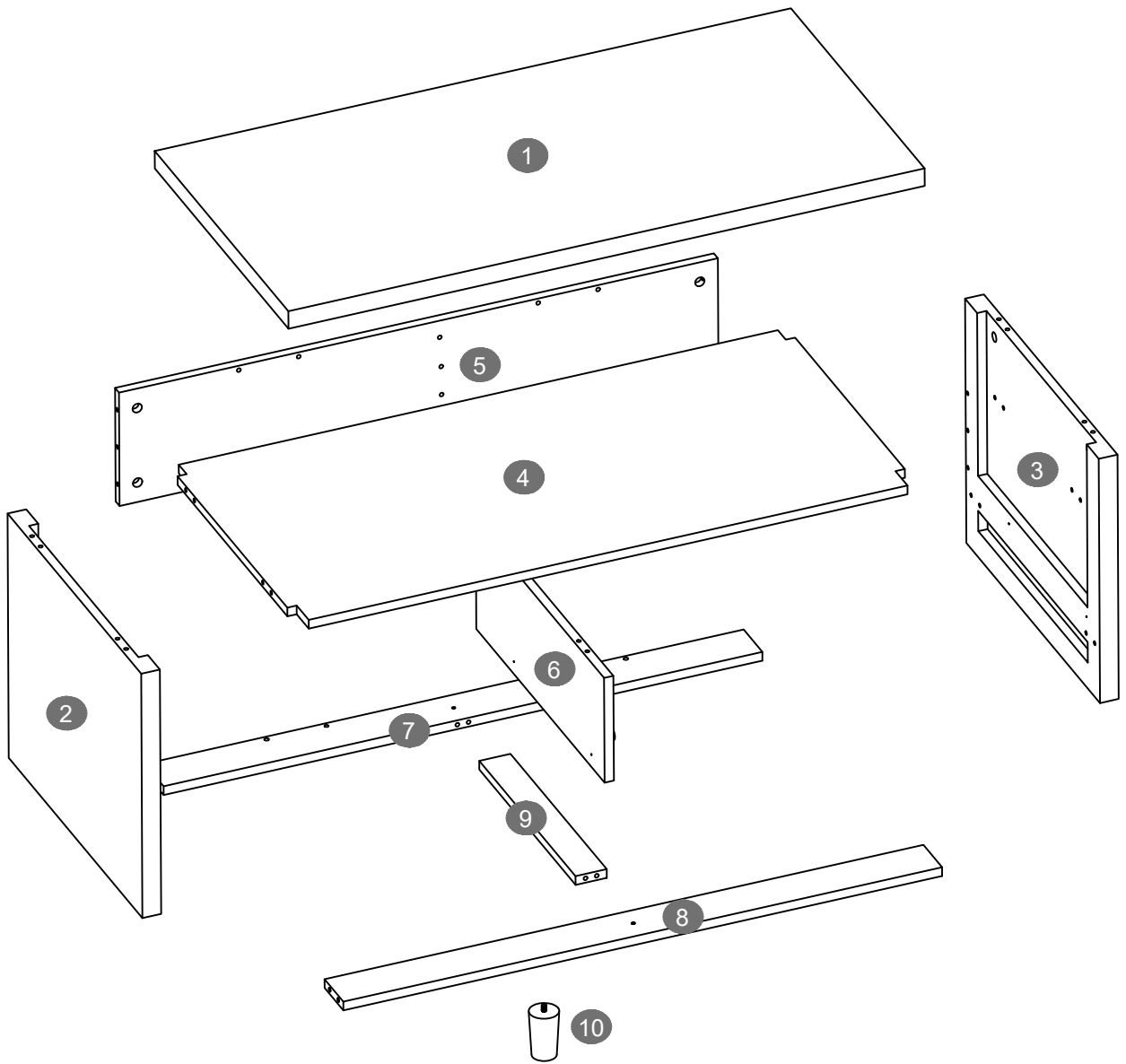







X 2

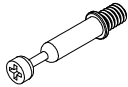
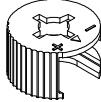
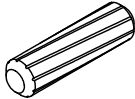
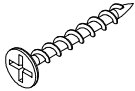
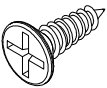

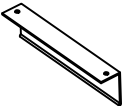
Components - Fittings

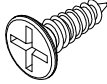
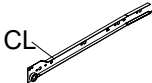
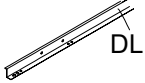
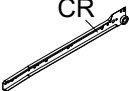
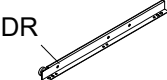
Please check you have all the panels listed below

Note: The quantities below are the correct amount to complete the assembly. In some cases more fittings may be supplied than are required.

A		31 pcs +3 pcs	B		31 pcs +3 pcs
C		24 pcs +2 pcs	D		12 pcs +1 pcs
E		26 pcs +2 pcs	F		1 pcs
G	  2 pcs	2 pcs	H		6 pcs
CL		2 pcs	DL		2 pcs
CR		2 pcs	DR		2 pcs
I		4 pcs	J		4 pcs

Step 1

E		3 pcs
CL		1 pc

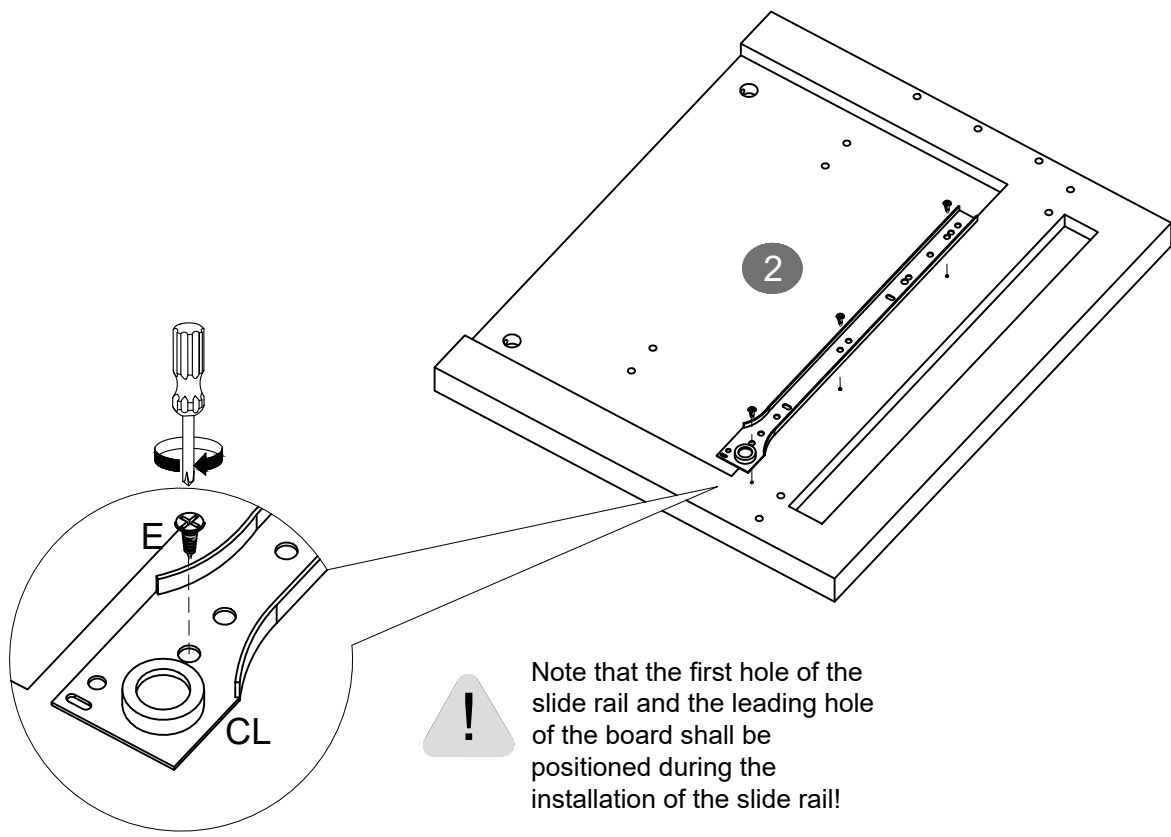

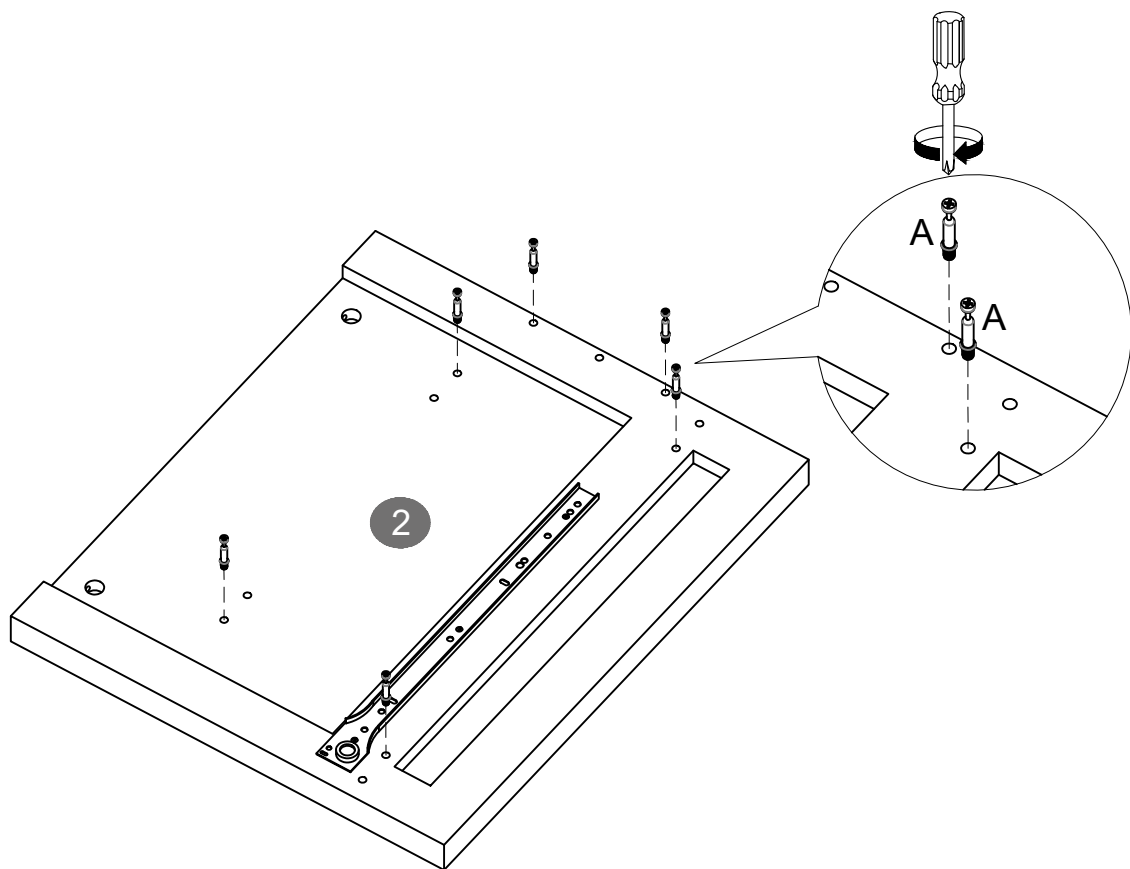

Step 2

A		6 pcs
---	---	-------



PRODUCT ASSEMBLY

Step 3

E		3 pcs
CR		1 pc

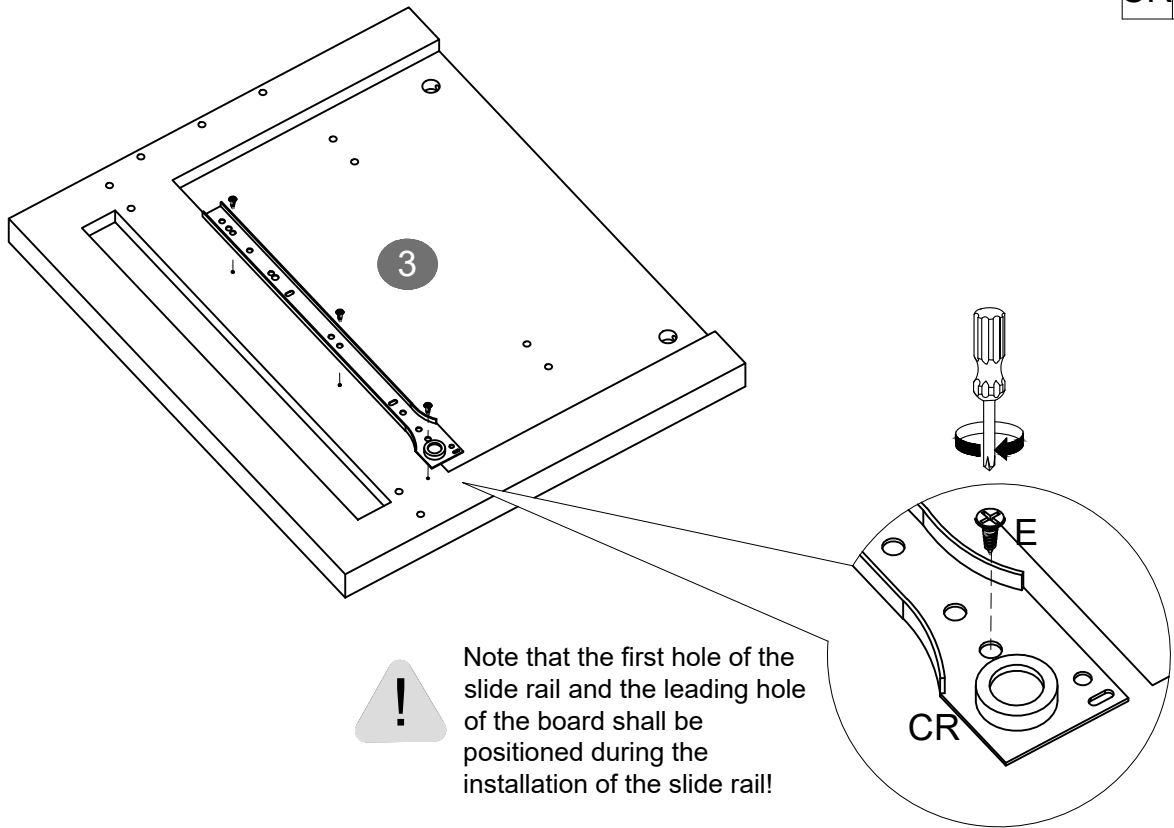

Step 4

A		6 pcs
---	---	-------

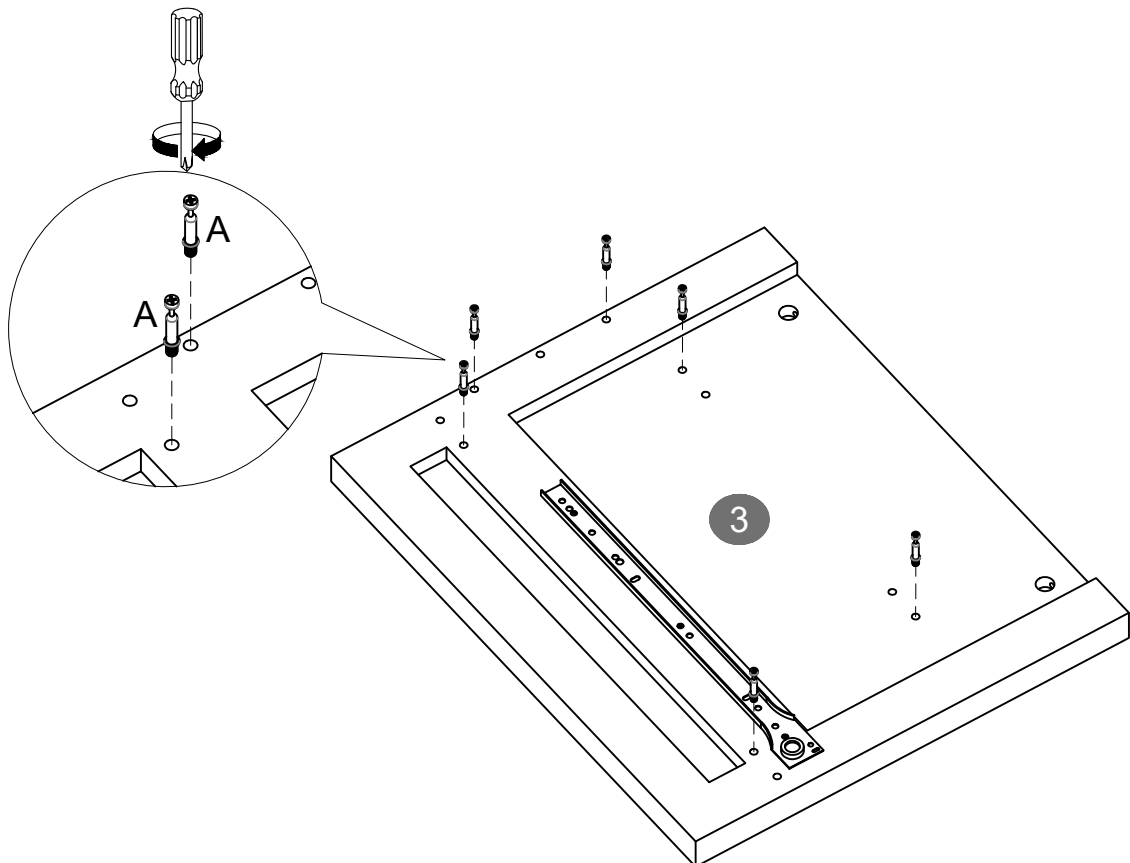

Step 5

H		6 pcs
---	---	-------

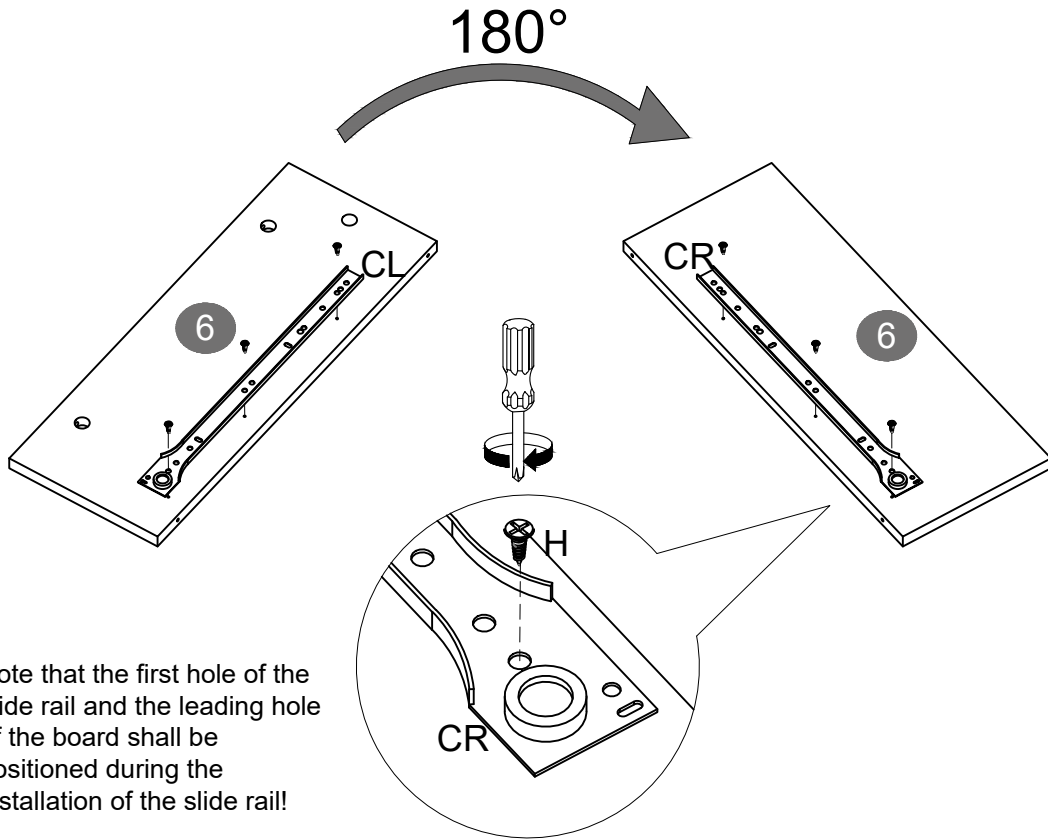

Note that the first hole of the slide rail and the leading hole of the board shall be positioned during the installation of the slide rail!

Step 6

A		3 pcs
---	---	-------

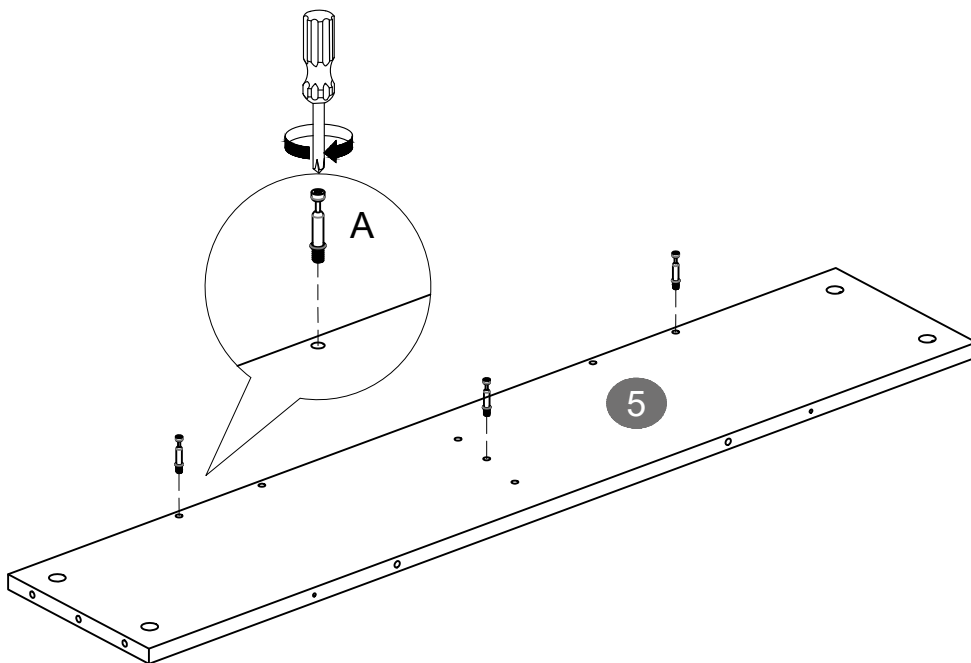

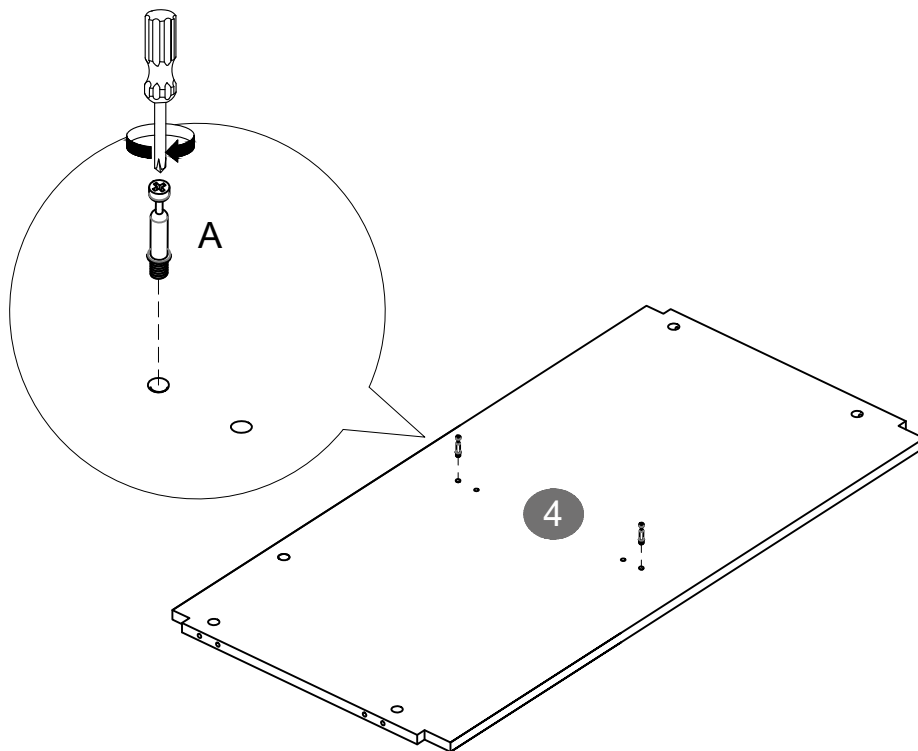

Step 7

A		2 pcs
---	--	-------



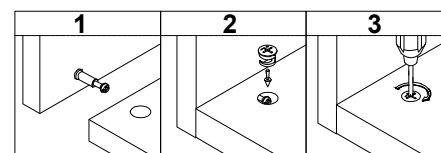
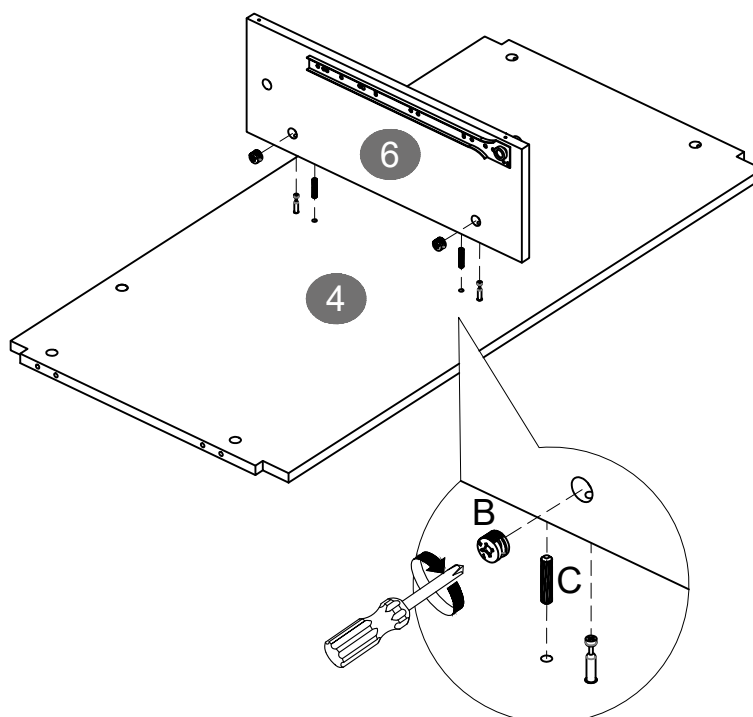

Step 8

B		2 pcs
C		2 pcs



PRODUCT ASSEMBLY

Step 9

B		3 pcs
C		4 pcs

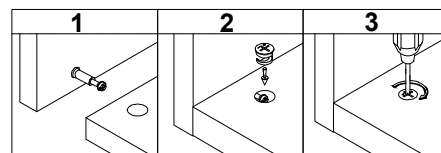
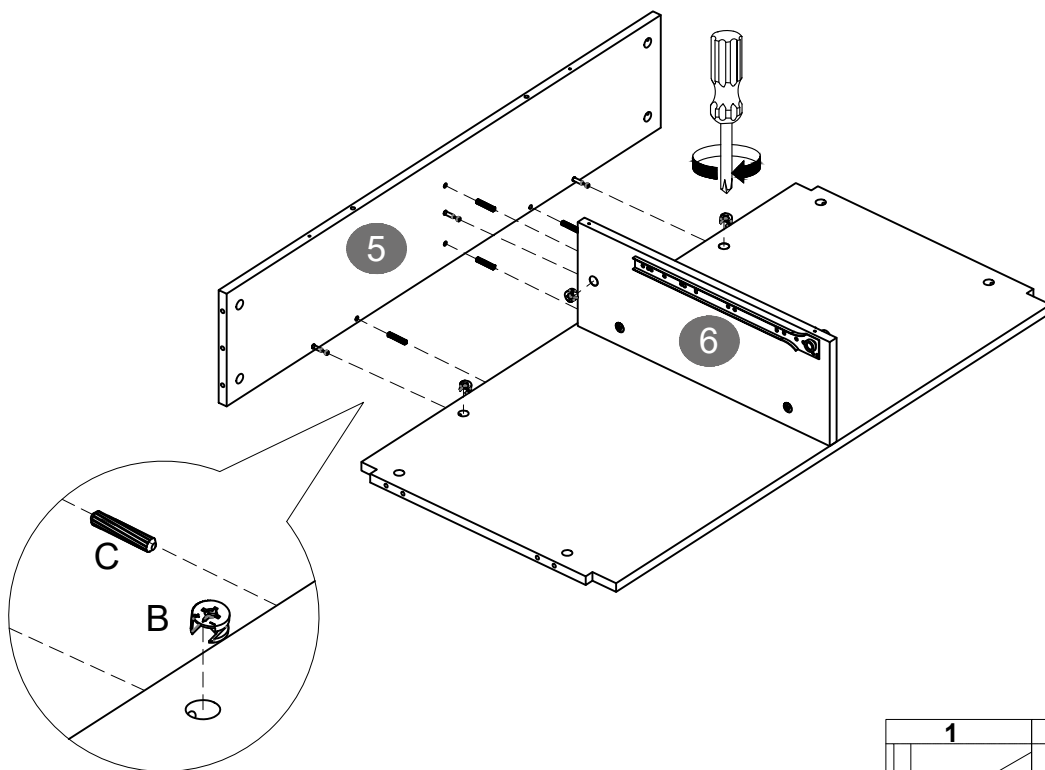

Step 10

A		1 pcs
---	---	-------

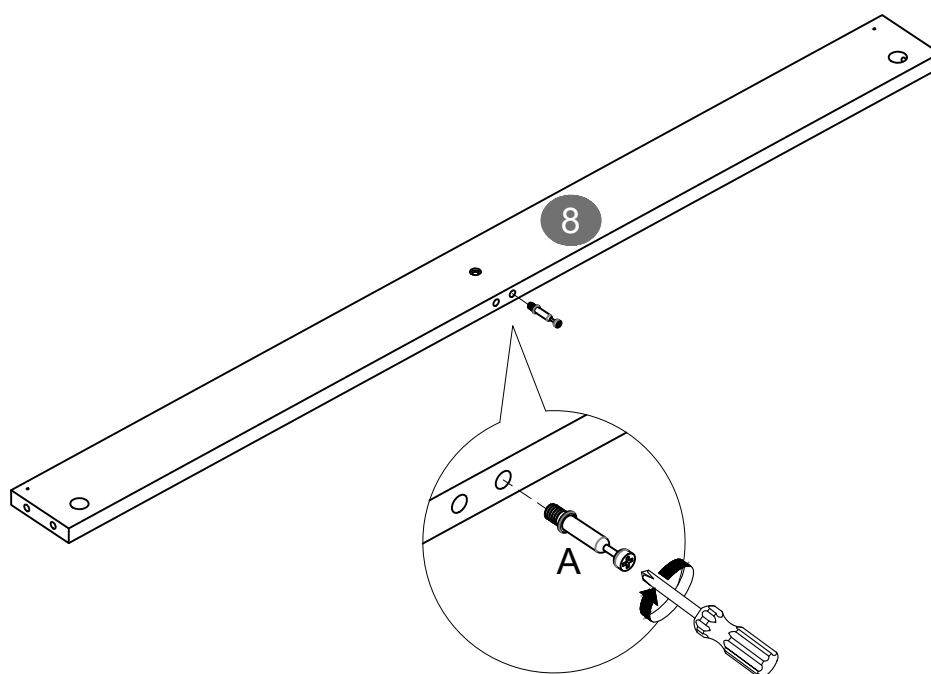

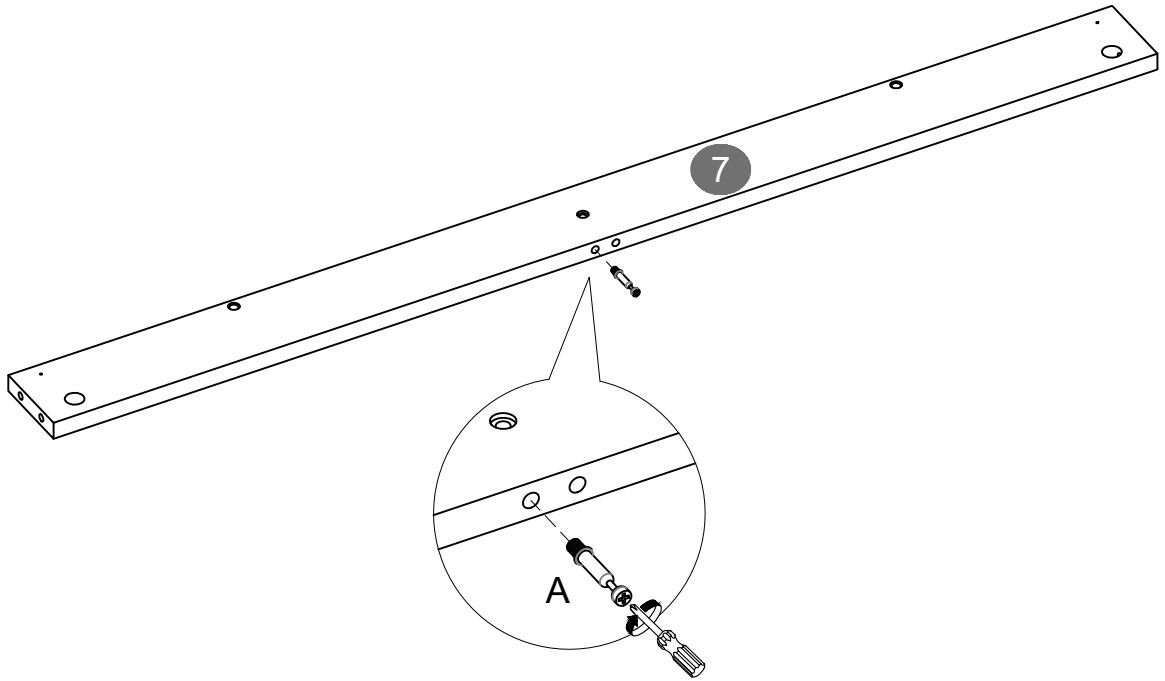

Step 11

A		1 pcs
---	--	-------



Step 12

B		2 pcs
C		2 pcs

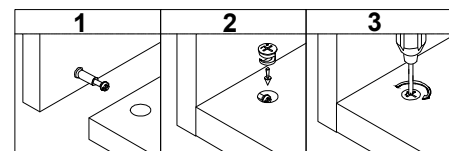
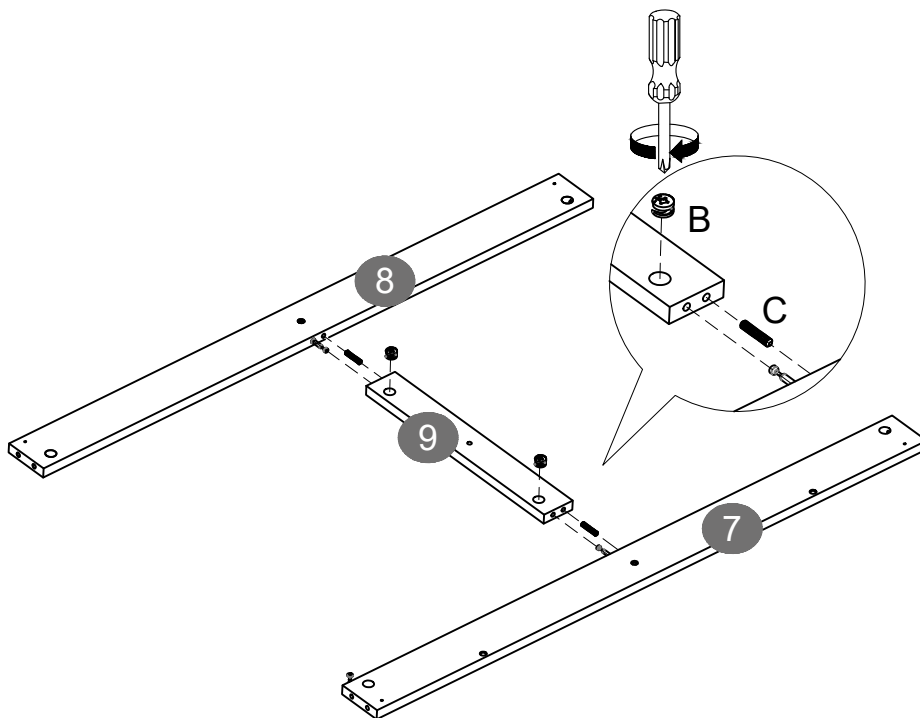

Step 13

C		2 pcs
---	--	-------

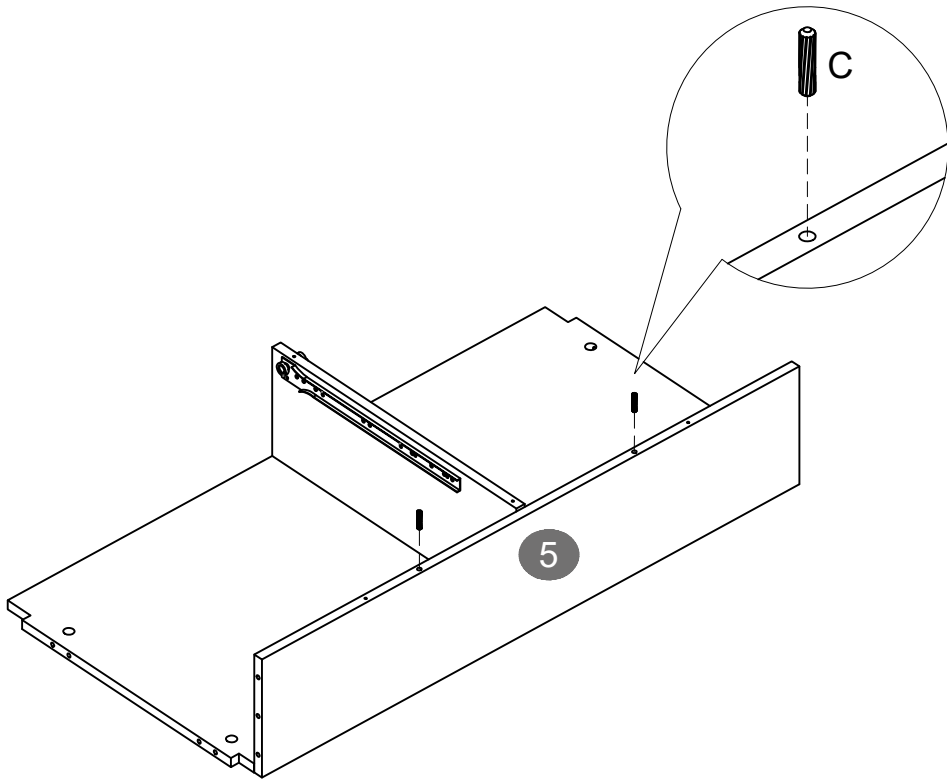

Step 14

D		4 pcs
---	---	-------

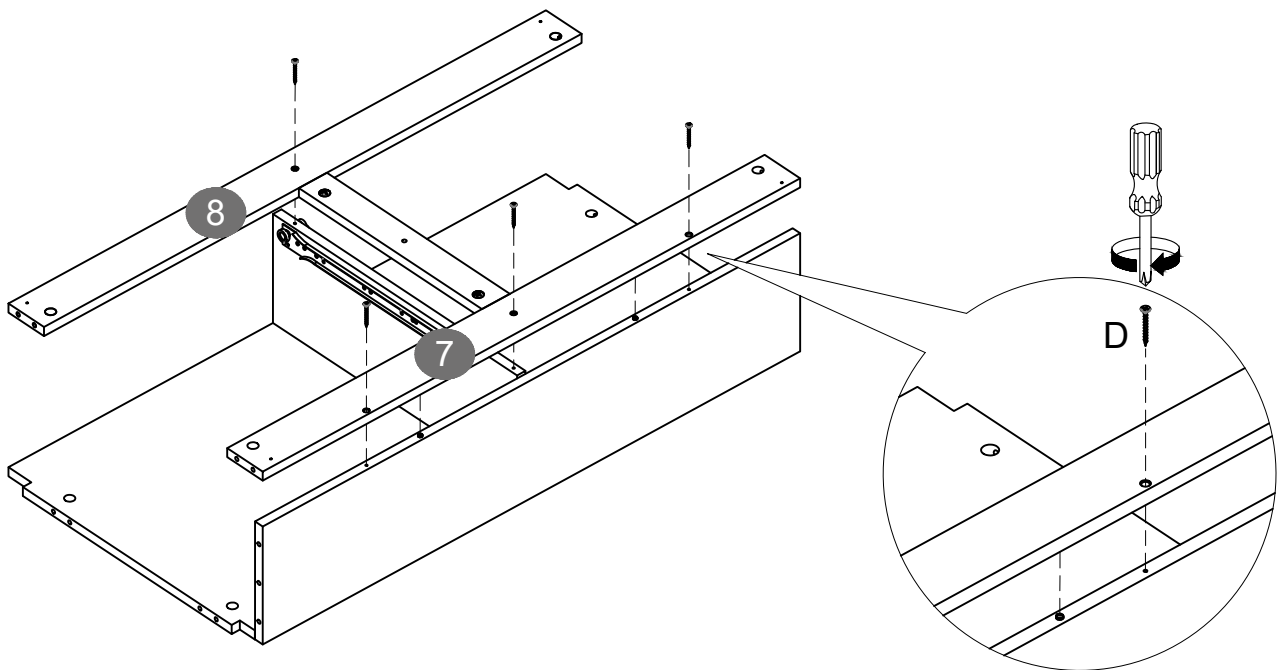

Step 15

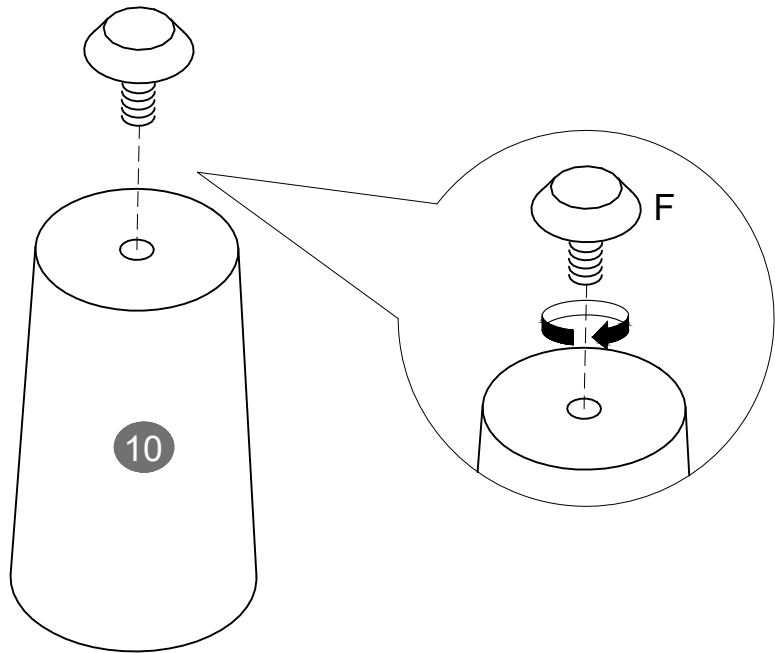

Step 16

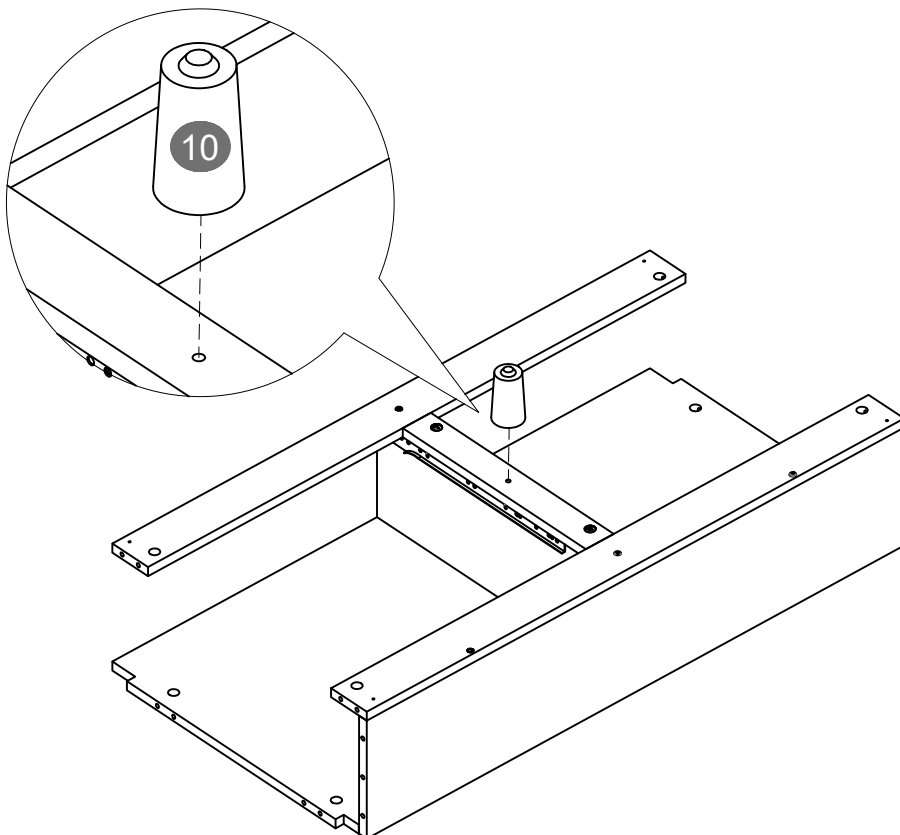

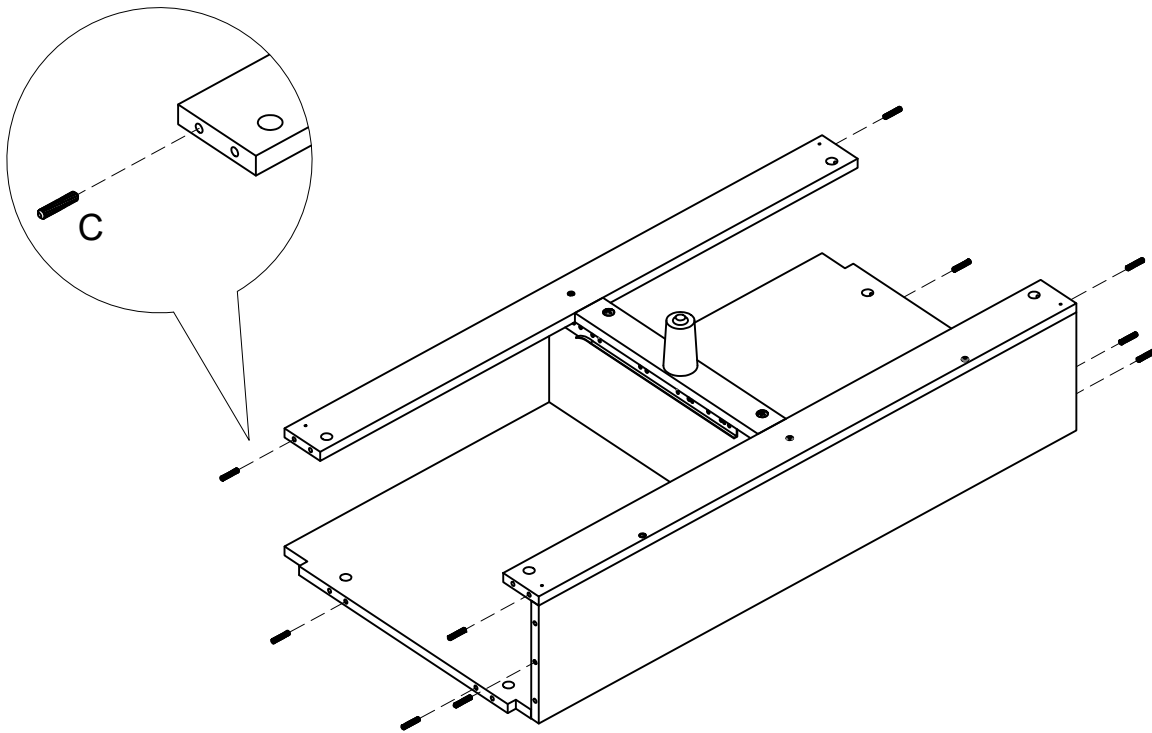

Step 17

C		10 pcs
---	--	--------



Step 18



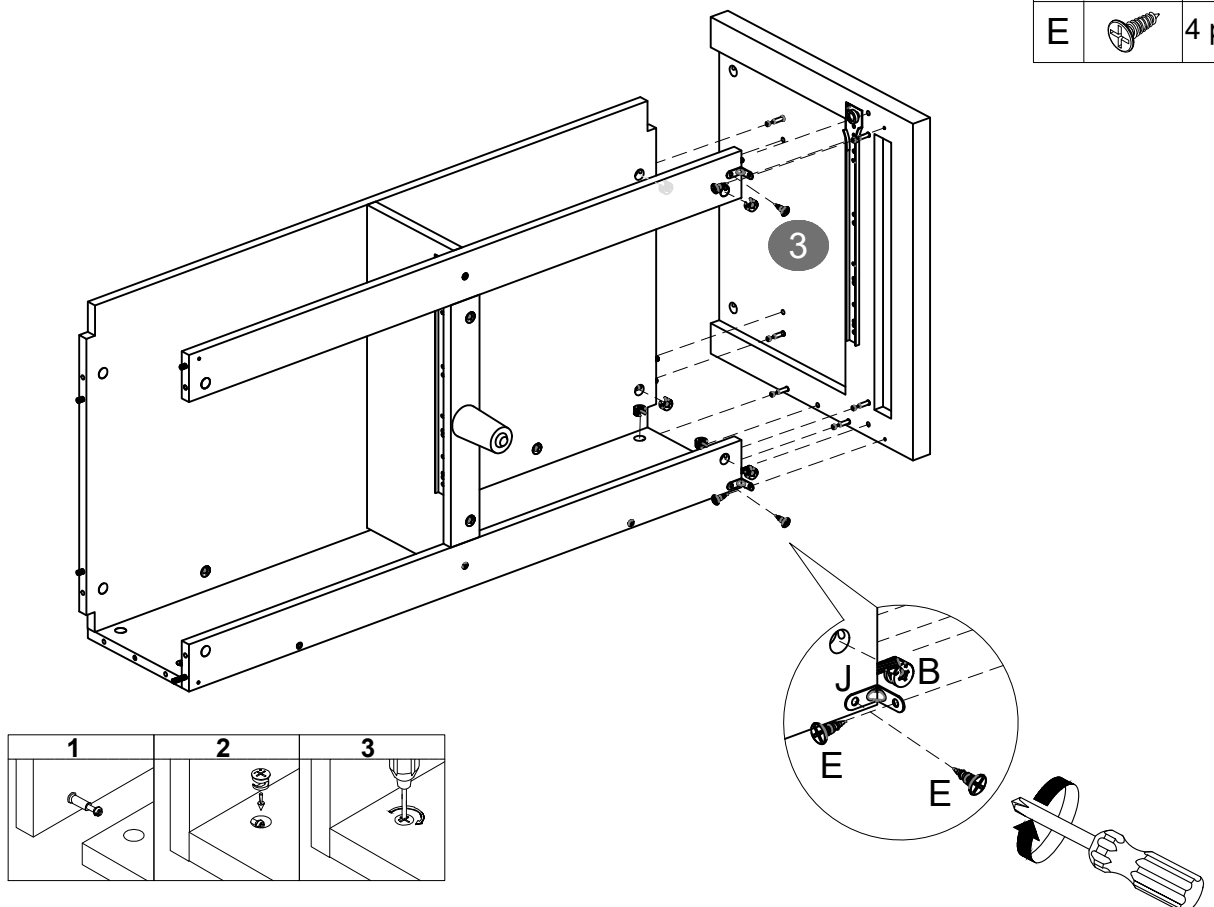

B		6 pcs
J		2 pcs
E		4 pcs

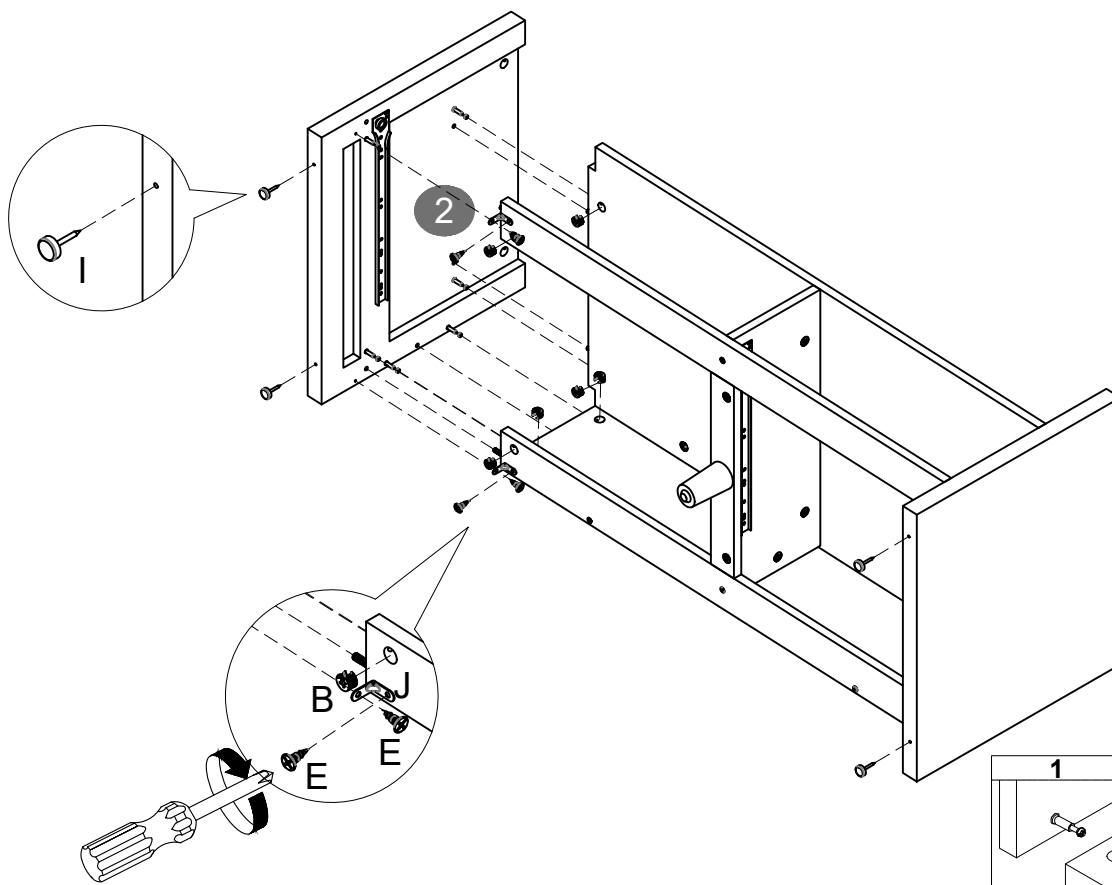

PRODUCT ASSEMBLY

Step 19



B		6 pcs
I		4 pcs
J		2 pcs
E		4 pcs

Step 20

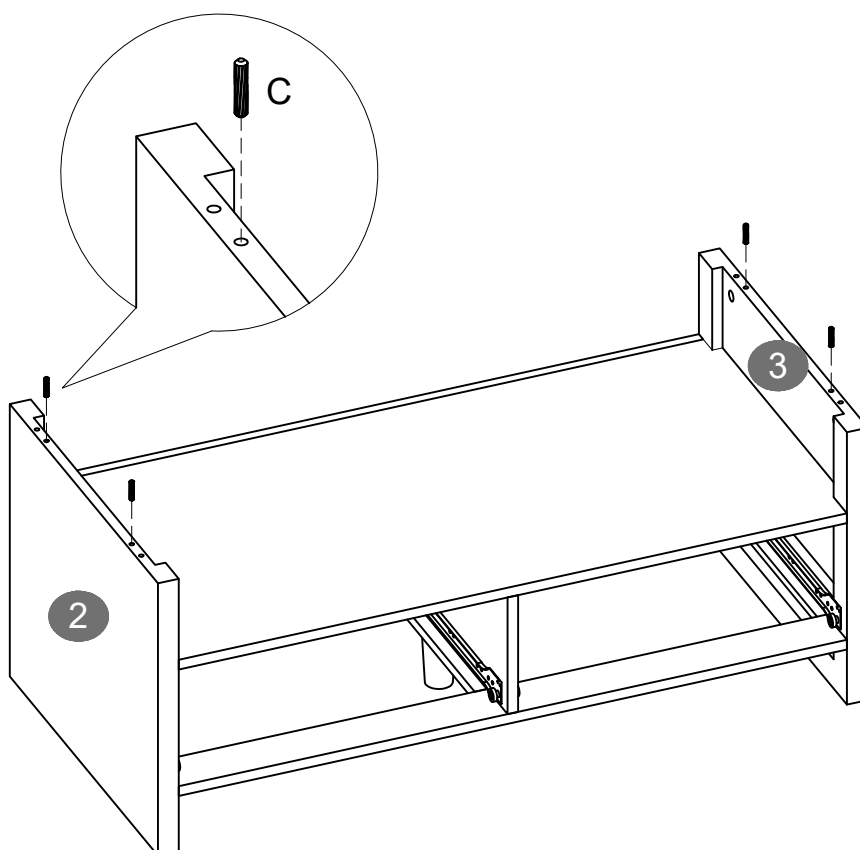

C		4 pcs
---	---	-------

Step 21

A  4 pcs

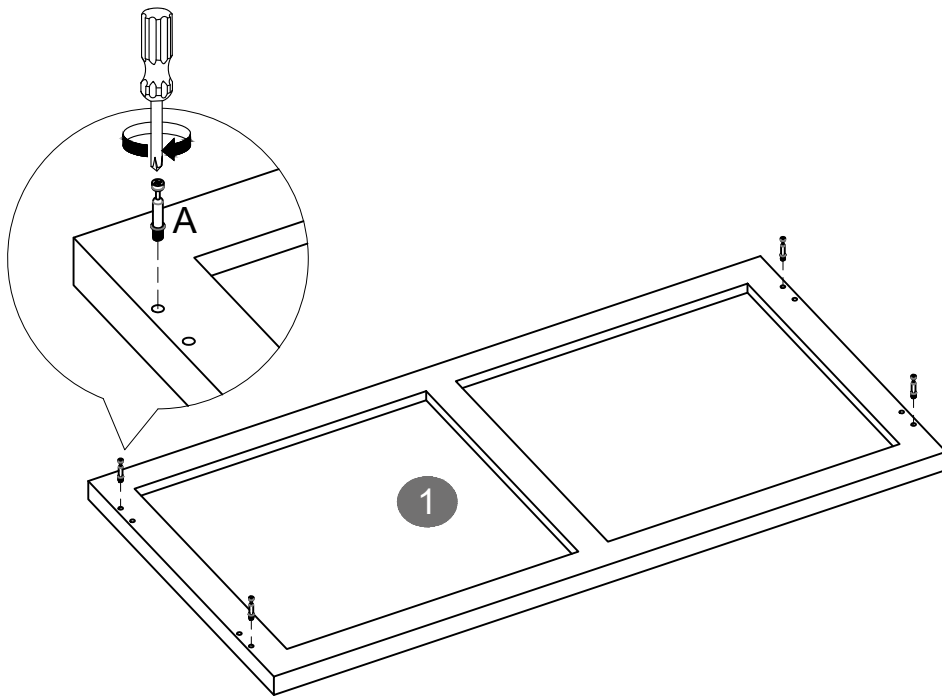

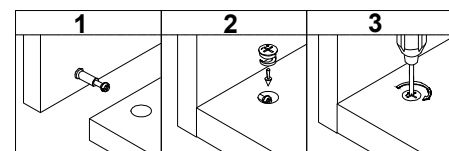
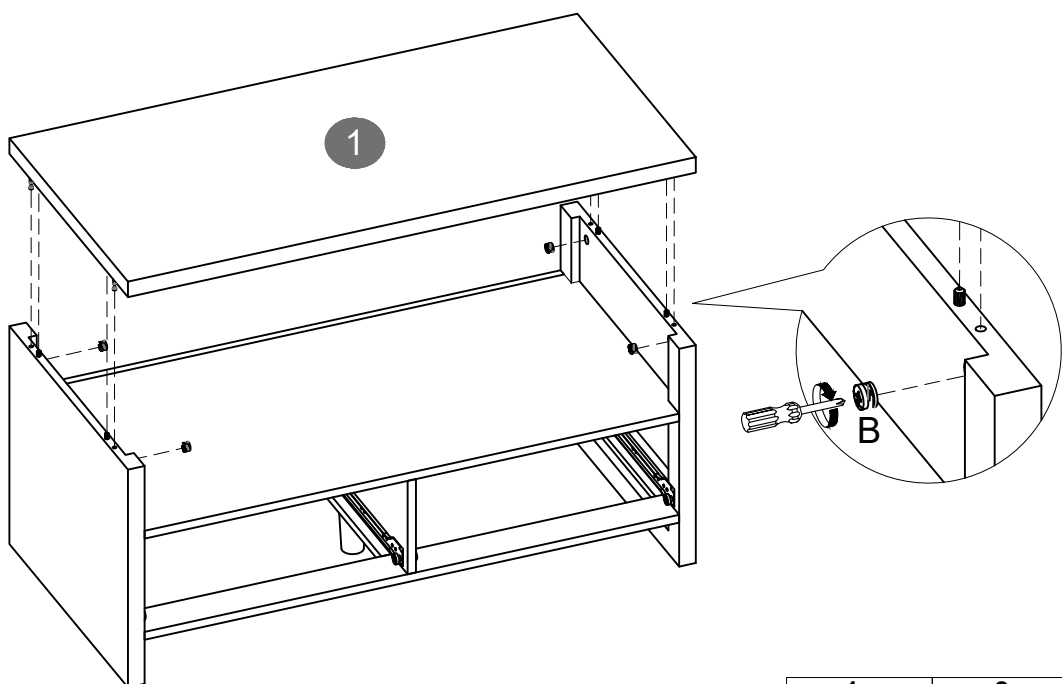

Step 22

B  4 pcs



Step 23

G		2 pcs
A		8 pcs

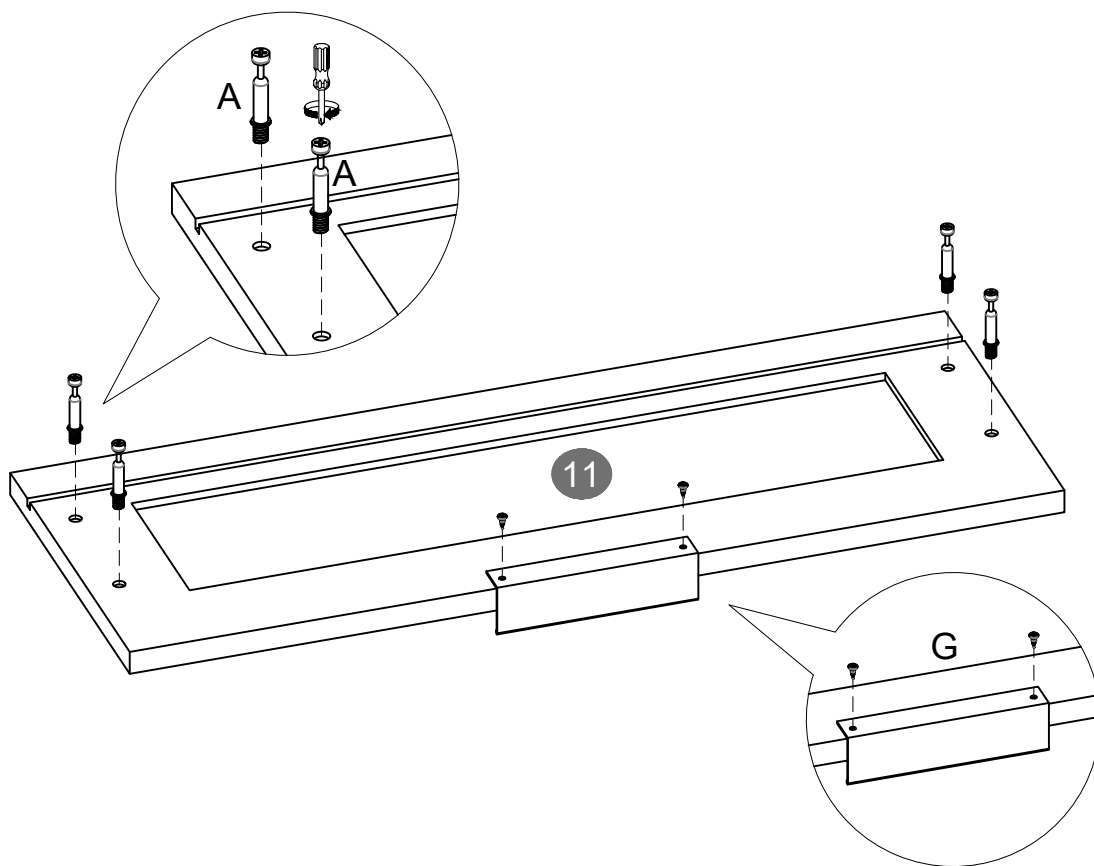

X 2

Step 24

D		8 pcs
---	---	-------

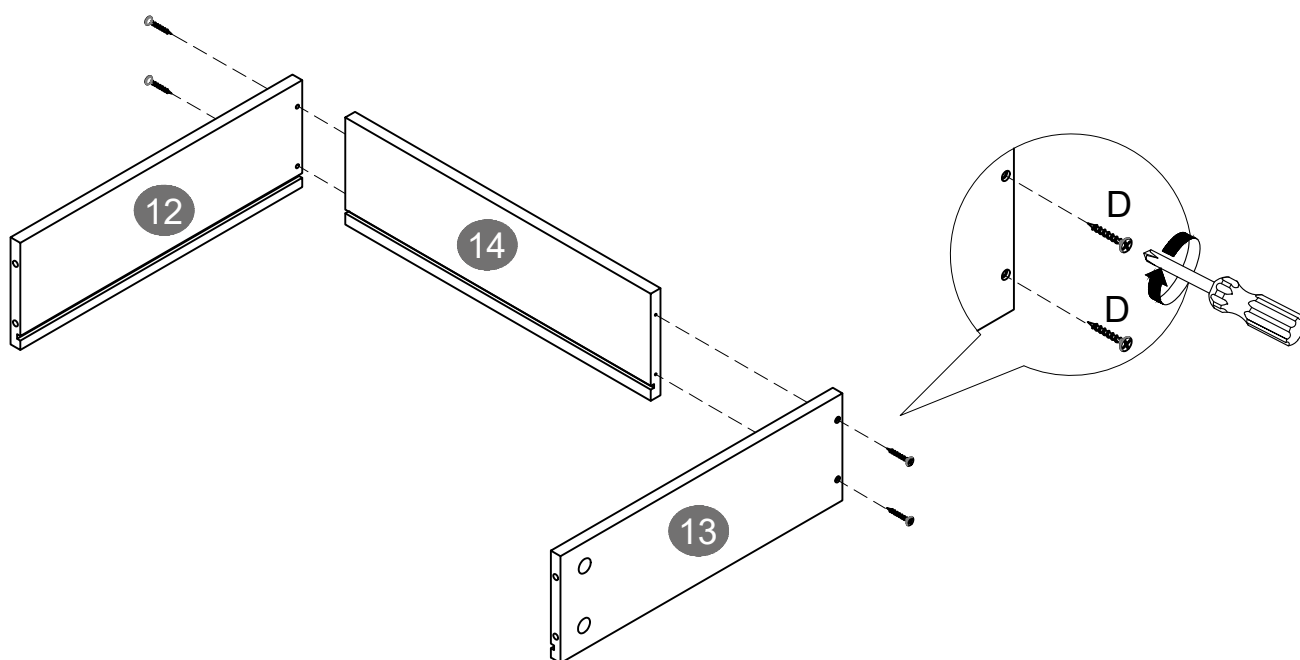

X 2

Step 25

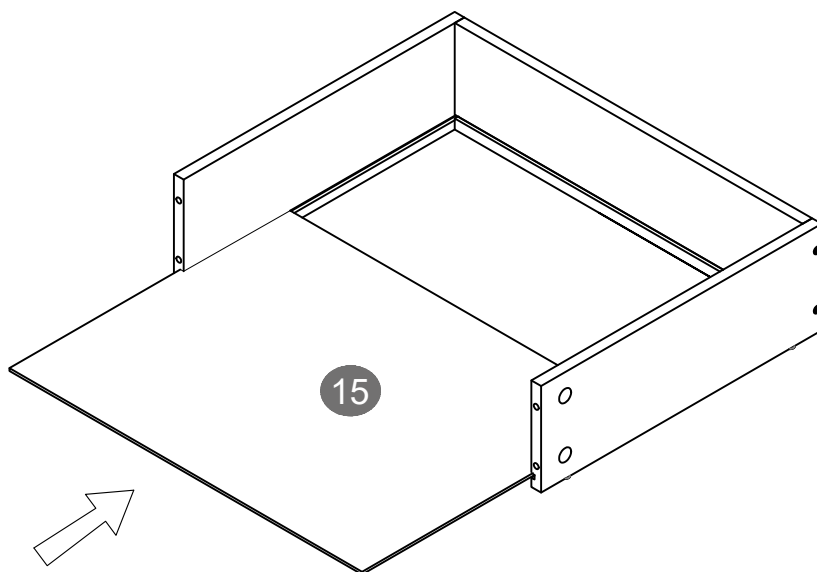

X 2

Step 26

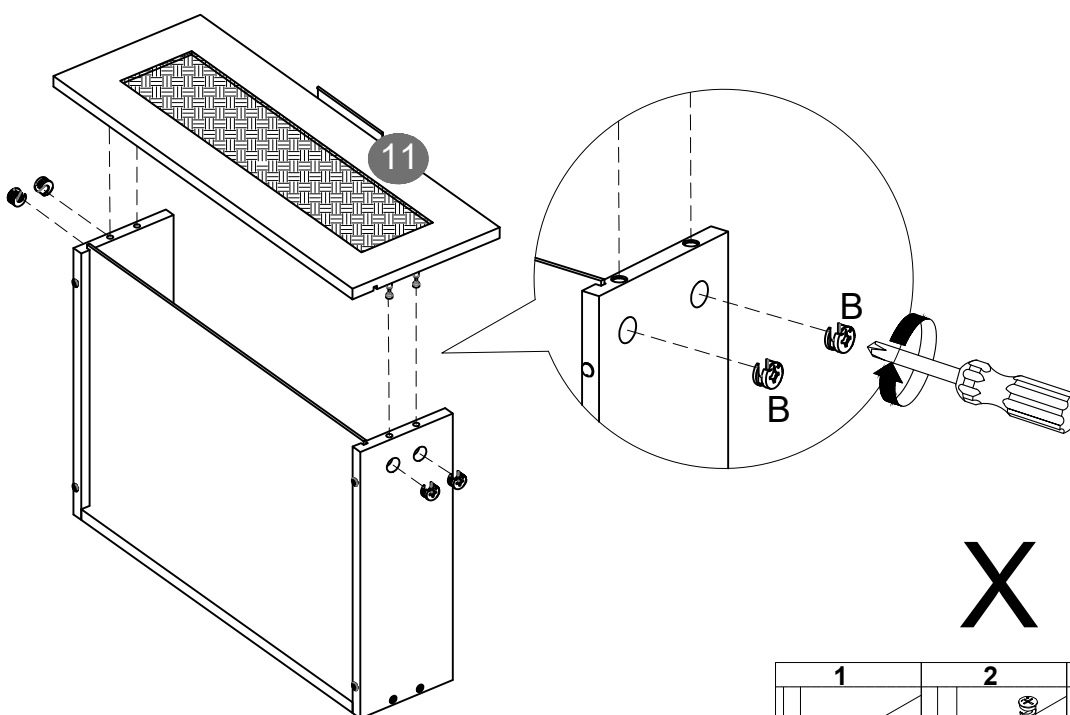

B  8 pcs



X 2

PRODUCT ASSEMBLY

Step 27

E		12 pcs
DR		2 pcs
DL		2 pcs

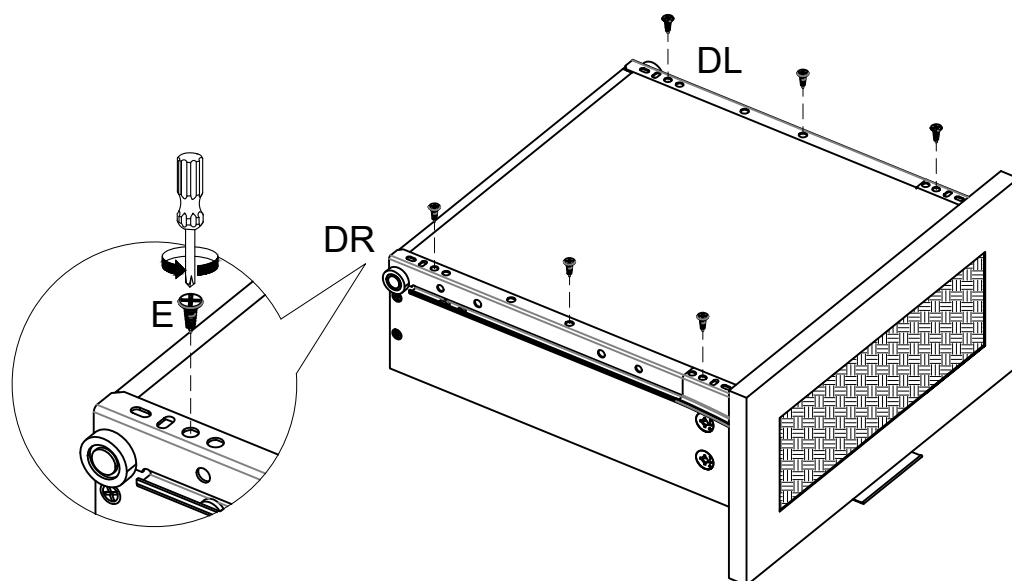
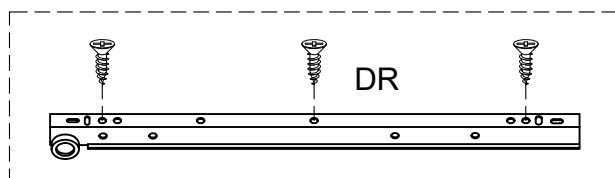
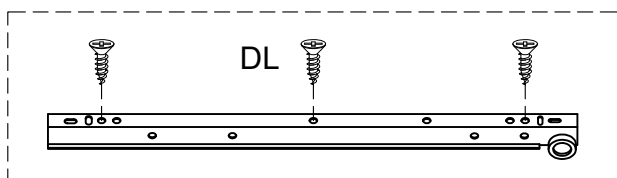

X 2

Step 28

