



Leaders in Reception Seating

Lesro Industries, Inc.
1 Griffin Road South
Bloomfield, CT
06002

Phone
860.243.3226
Fax
860.243.5392
www.lesro.com

Assembly Instructions Mystic Guest Chairs and Sofas

Tools required: 9/16" ratchet, Allen wrenches (included in hardware pack)

Note: These instructions are intended for various models and configurations, with and without arms. Your products may not look exactly as those shown in the diagrams.

Important: The assembly process requires that some hardware be kept loose until later in the sequence. Follow these instructions closely to ensure correct assembly.

Recommendation: Retighten all bolts on a seasonal basis to ensure your product remains strong and stable for many years of use.

Weight Capacity: All chairs in these series have a weight capacity of 300 lbs. per seat, unless otherwise stated.

Parts List

Leg Frames, left & right
Lower Cross Tube (1" dia), 2pcs.
Back Cross Tube (1/2" dia)
Seat Cushion
Back Cushion

Hardware Pack

2" Allen Bolts, 4 pcs.
1/2" Allen Bolts, 2 pcs.
3" Hex Bolts, 2 pcs.
Washers, 2 pcs.
3" Allen Bolts, 4 pcs.
Allen Wrenches, 2 sizes

Single Chairs

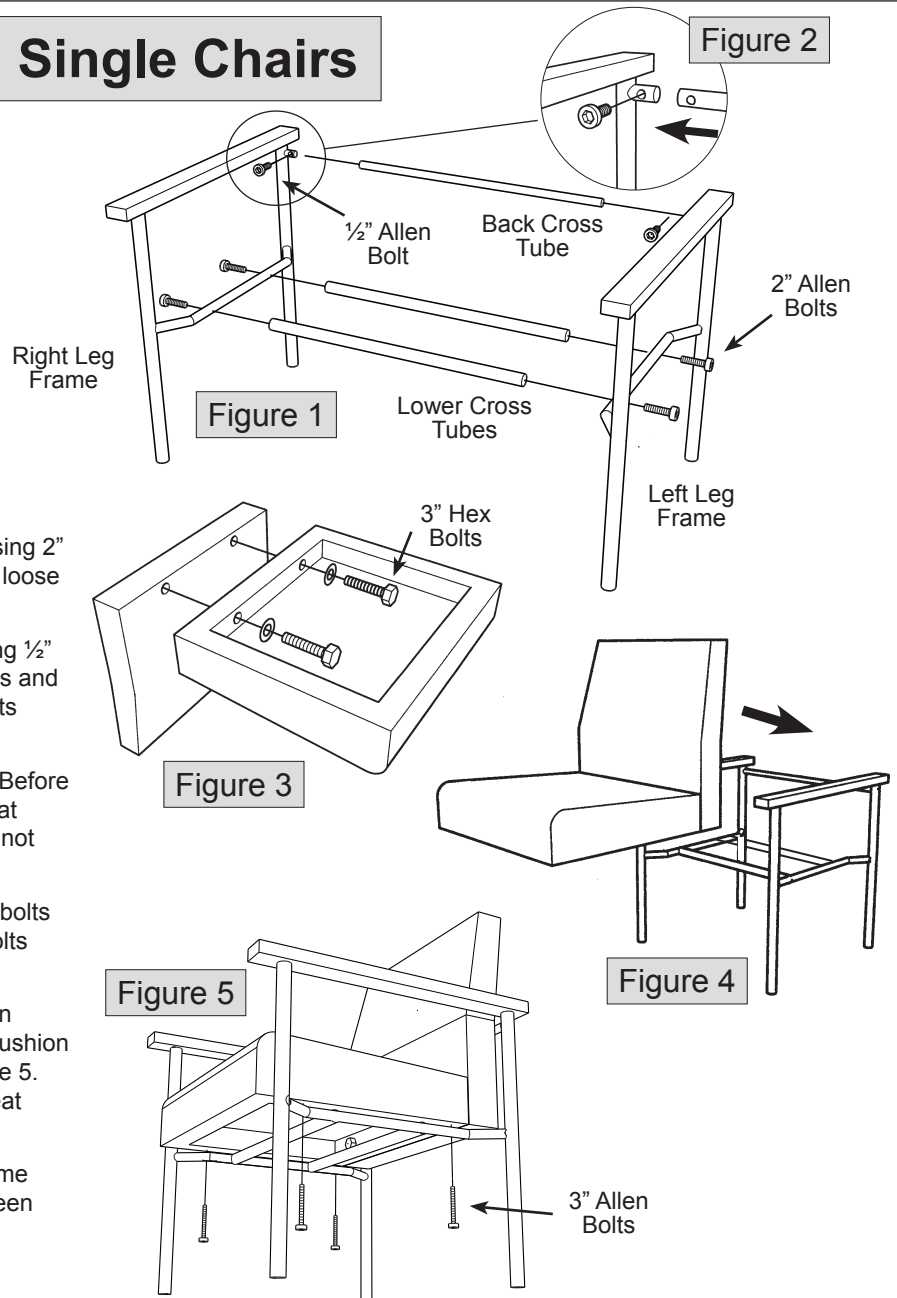

1. Unpack and identify all parts.
2. Connect lower cross tubes between leg frames using 2" Allen bolts as shown in figure 1. Keep these bolts loose for now. (Leave about 1/4" of exposed threads)
3. Connect back cross tube between leg frames using 1/2" Allen bolts as shown in figures 1 and 2. Align holes and insert bolts from front of chair. Tighten these 2 bolts securely.
4. Tighten lower cross tube bolts from step 2 tightly. Before doing so, make sure all four feet are sitting on a flat surface and make sure overall frame assembly is not leaning to one side or the other.
5. Attach seat cushion to back cushion using 3" hex bolts and washers as shown in figure 3. Keep these bolts loose for now.
6. Set cushion assembly into chair frame as shown in figure 4. Align holes in frame with holes in seat cushion and connect using 3" Allen bolts as shown in figure 5. Tighten these bolts securely while making sure seat cushion is centered between front legs tubes.
7. Tighten 3" hex bolts from step 5 securely at this time while making sure back cushion is centered between back leg tubes.
8. Your product is now assembled and ready to use.

Thank you for purchasing a Lesro product.
Need assistance with assembly? Call Lesro customer service 1-800-275-7545.
Visit us on-line at www.lesro.com



Leaders in Reception Seating

Lesro Industries, Inc.
1 Griffin Road South
Bloomfield, CT
06002

Phone
860.243.3226
Fax
860.243.5392
www.lesro.com

Assembly Instructions Mystic Guest Chairs and Sofas

Tools required: 9/16" ratchet, Allen wrenches (included in hardware pack)

Note: These instructions are intended for various models and configurations, with and without arms. Your products may not look exactly as those shown in the diagrams.

Important: The assembly process requires that some hardware be kept loose until later in the sequence. Follow these instructions closely to ensure correct assembly.

Recommendation: Retighten all bolts on a seasonal basis to ensure your product remains strong and stable for many years of use.

Weight Capacity: All chairs in these series have a weight capacity of 300 lbs. per seat, unless otherwise stated.

Connecting Chairs & Sofas

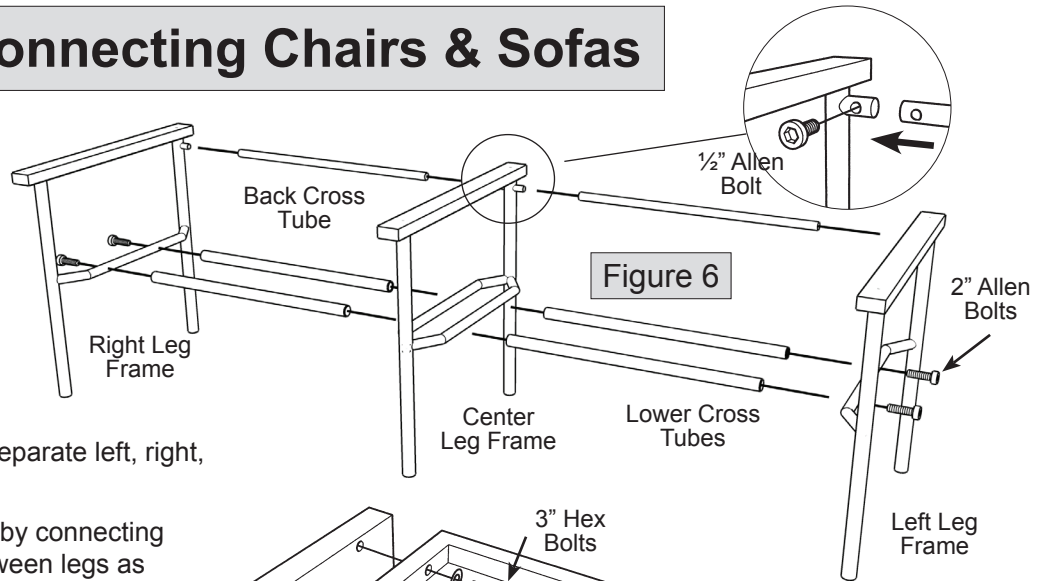
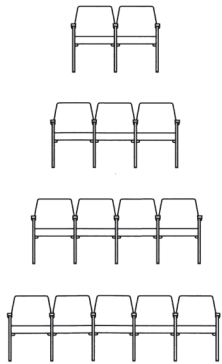

1. Unpack and identify all parts. Separate left, right, and center leg frames.
2. Build complete frame assembly by connecting back and lower cross tubes between legs as shown in figure 6. Use 2" Allen bolts for lower cross tubes and keep these bolts loose for now. (Leave about 1/4" of exposed threads) Use 1/2" Allen bolts for back cross tubes. Tighten these bolts very securely at this time.
3. Frame can be set aside for the time being.
4. Attach seat cushions to back cushions using 3" hex bolts and washers as shown in figure 7. Keep these bolts loose for now. Repeat until all cushion sets are assembled.
5. Set each cushion assembly into each chair frame as shown in figure 8. Align holes in frame with holes in cushions and connect using 3" Allen bolts as shown in figure 9.
6. Tighten all bolts securely at this time, including all lower cross tube bolts from step 2 and all seat cushion hex bolts from step 4.
7. Your product is now assembled and ready to use.

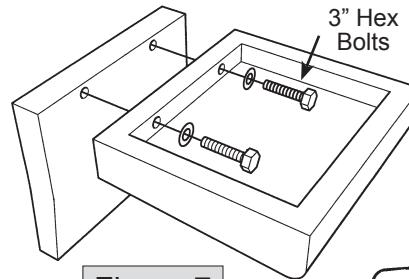

Figure 7

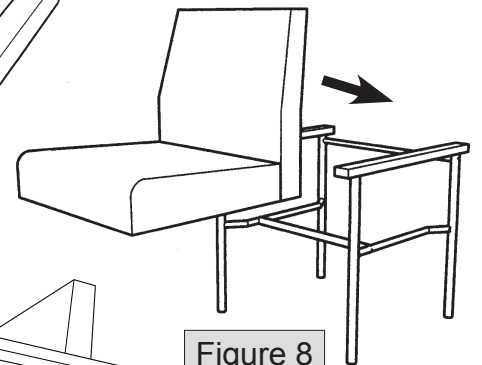

Figure 8

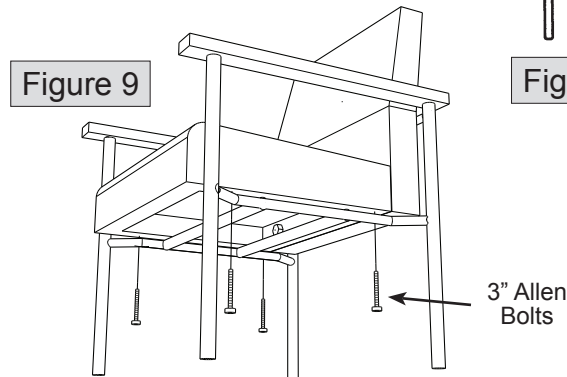

Figure 9

Thank you for purchasing a Lesro product.

Need assistance with assembly? Call Lesro customer service 1-800-275-7545.

Visit us on-line at www.lesro.com