

# Wire Shelving Unit

## ASSEMBLY INSTRUCTIONS

Thank you for purchasing this Product.  
We hope that you will enjoy using it.  
**SHOULD YOU NEED ASSISTANCE WITH YOUR PRODUCT,  
PLEASE DO NOT RETURN YOUR  
PRODUCT TO THE STORE!**

For all questions, concerns or assistance, please call  
**Consumer Hot Line**

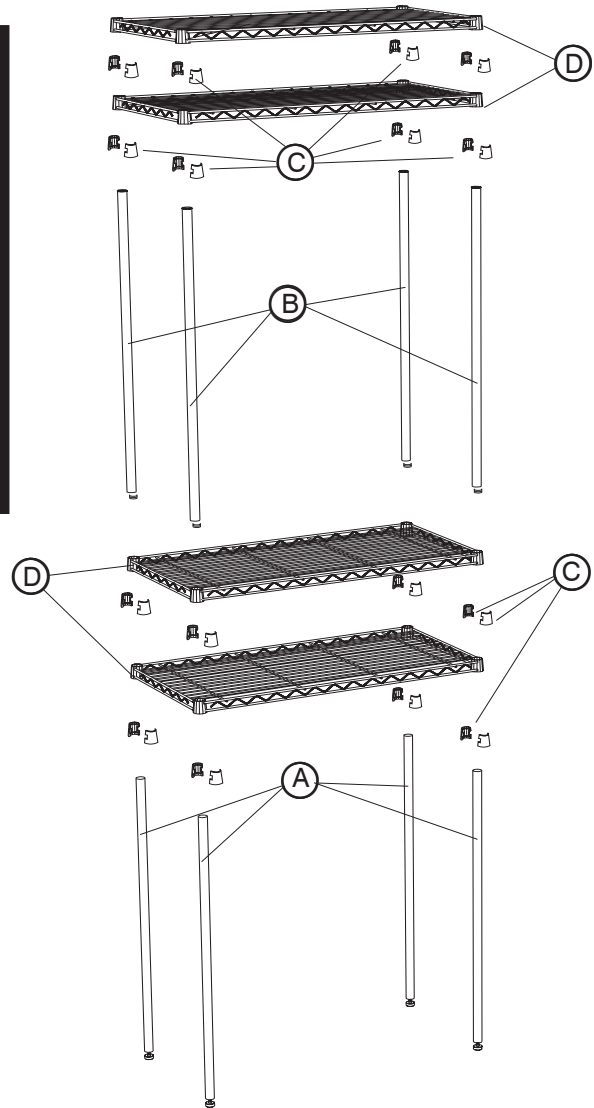

### Sort and count your parts!

PARTS LIST			
LETTER CODE	DESCRIPTION	QTY.	PART NO.
(A)	Lower Post (with leveler)	4	
(B)	Upper Post (with plastic cap)	4	
(C)	Half-Sleeve	32	
(D)	Shelf	4	

- 1** To build the four corner posts, screw the (A) Lower Posts (with levelers) onto the (B) Upper Posts (with plastic caps). Hand tighten.

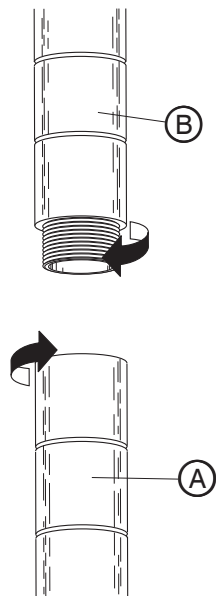

- 2** Decide where you want to mount the **BOTTOM SHELF** (no more than 12" from the floor). At this position on each post, place two (C) Half-Sleeves around the post, with the **LARGE** ends of the sleeves toward the **BOTTOM** of the post and the ridges inside the sleeves fitting into the grooves in the post. Press the two halves until they snap together.

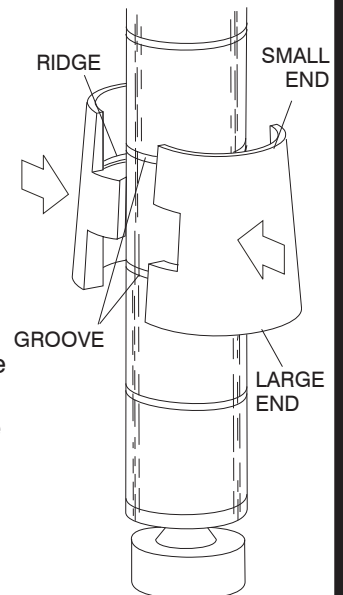

- 3** Stand a **D** Shelf on end, and from the **BOTTOM** side of the shelf (the bottom side is recessed), slide the **TOP** end of a post through a corner hole until the half-sleeves are seated in the corner hole. Repeat with remaining posts.

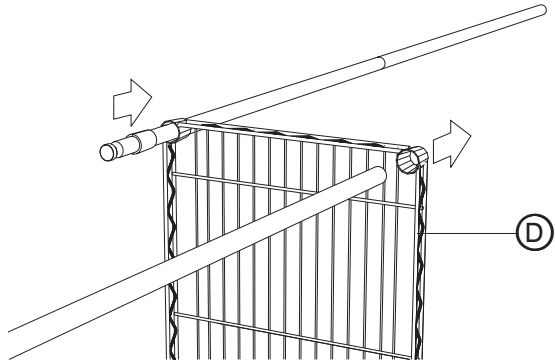

- 4** Set the unit upright. Press the shelf firmly at each shelf corner, close to the corner holes, until firmly seated.

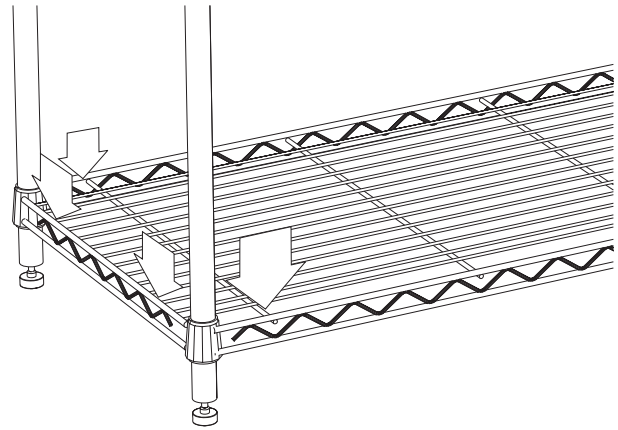

- 5** Snap half-sleeve sets onto all four posts at the desired height for the **NEXT** shelf. Lower this shelf into position and press until fully seated. Install the third and fourth shelves in the same manner, with both shelves mounted **ABOVE** the post seams.

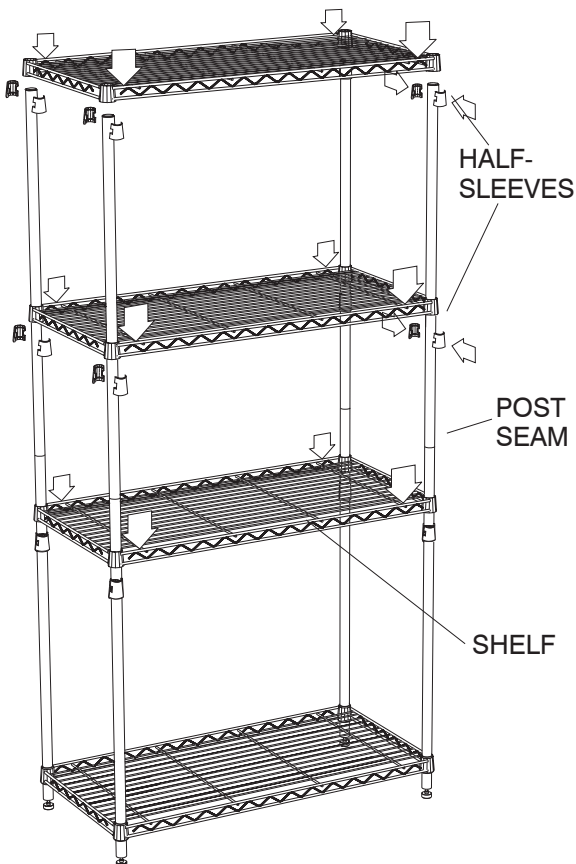

- 6** Set the unit into place and adjust the levelers at the bottoms of the posts until shelves are level in both directions.

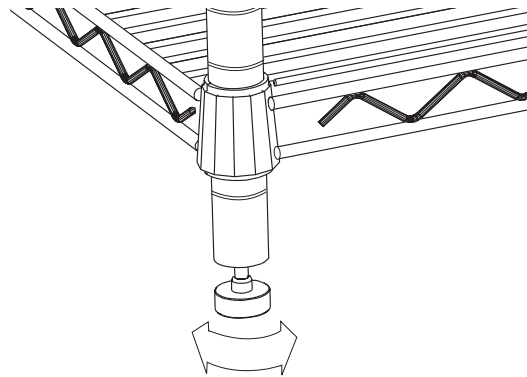

**(SHOWN ASSEMBLED)**