

Assembly Instructions

Caution: You must read this before you proceed

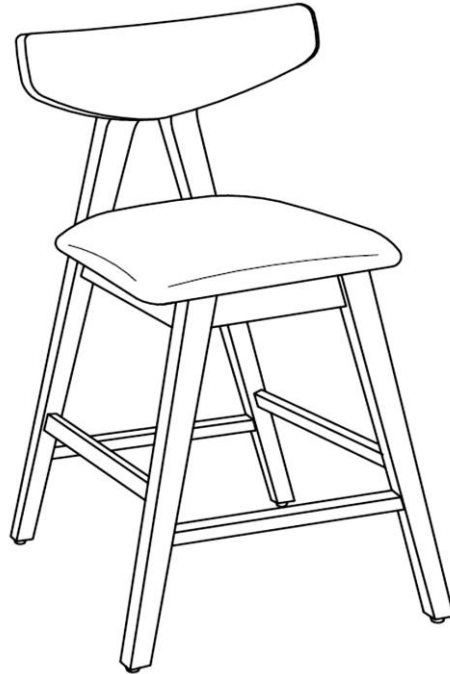



COUNTER STOOL





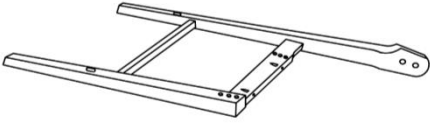
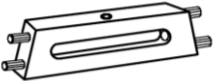
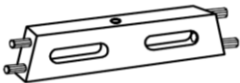

WARNING: These Bar Stools are intended only for normal use with all four legs on the ground. These consumer bar stools have relatively thin legs and are not designed to be sat in with only two chair legs on the ground (as from tipping back, forward, or to the side), and such can cause stress and failure of one or more barstool legs. Any misuse of the barstools voids any warranties, expressed or implied.

Part List

Label	Picture	Description	QTY
A	A line drawing of a side frame left part, which is a rectangular frame with two horizontal bars and two vertical bars. It is shown from a three-quarter perspective.	Side Frame Left	1

B		Side Frame Right	1
C		Front Stretcher	1
D		Back Stretcher	1
E		Front & Back Rail	2
F		Top Rest	1
G		Cushion Seat	1

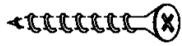
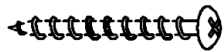
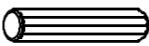
Hardware

Label	Picture	Description	QTY
①		JCBC M6 x 25mm + S/W M6 + F/W M6 x 13mm	5
②		Allen Wrench M4	1
③		JCBC M6 x 50mm + S/W M6 + F/W M6 x 13mm	5
④		FH Screw #8 x 32mm	5
⑤		PH Screw M4 x 38mm	5
⑥		Wood Dowel M8 x 25mm	3
⑦		Screwdriver(Not Provided)	1

Assembly Preparation

Before Beginning Assembly:

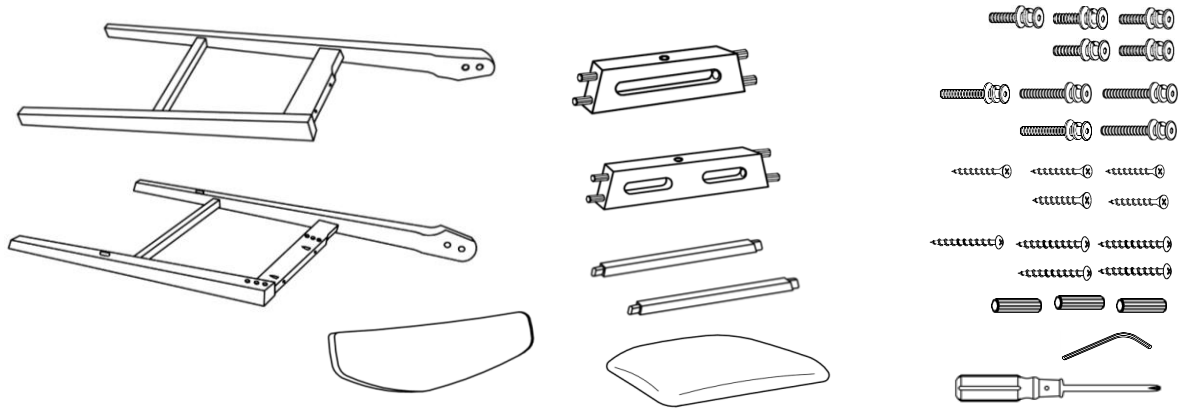

- Read instructions, cover to cover-



- Have 2 adults on hand for assembly-



- Do not assemble on flooring or carpet-



- Assemble on a clean non-marring surface (packing foam)-



- Save all packaging until finished-

Assembly Steps

Overview

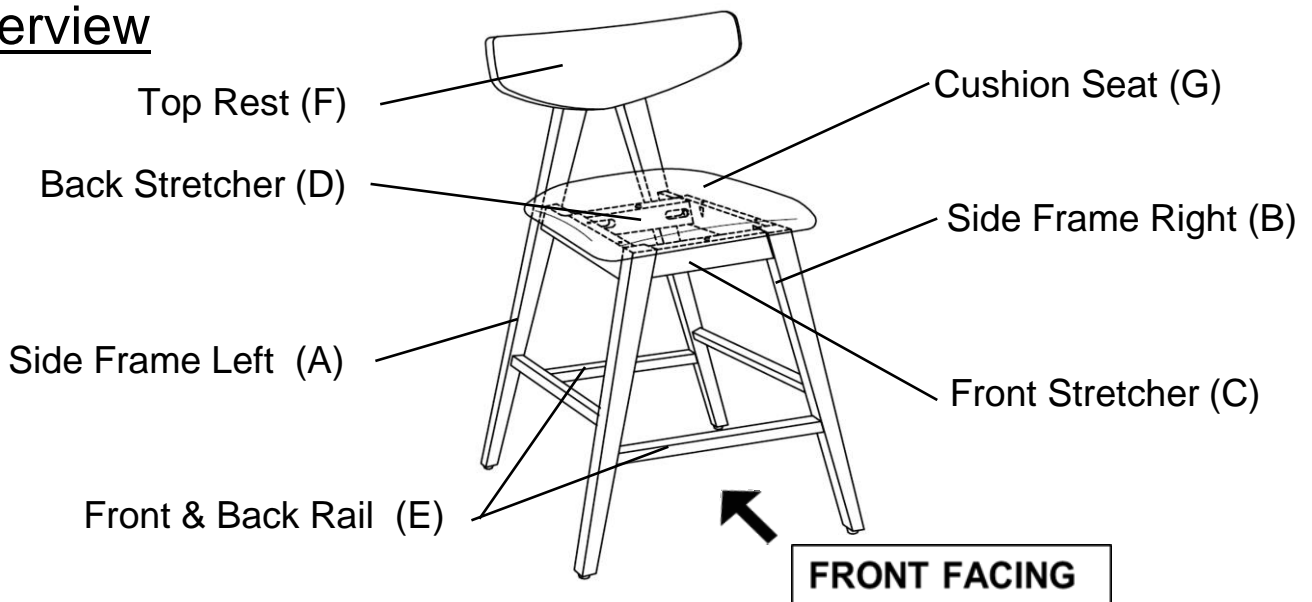

This Bar Stool has multiple parts and may require up to some 30 minutes to assemble. To give you an overview of the Bar Stool parts, the above picture is to help you put the various parts into perspective. Please read through the instructions below to familiarise yourself with the parts and steps before assembly.

Step 1

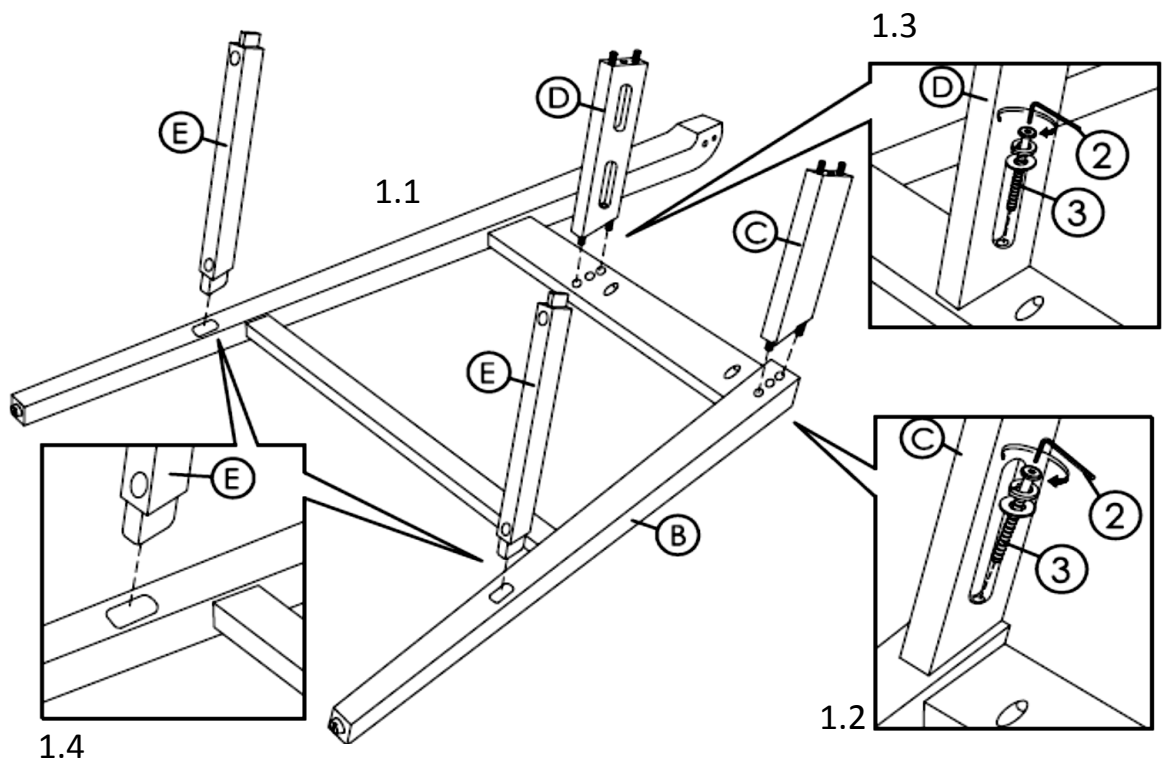

1.1 Place the Side Frame Right (B) on a soft surface to avoid any scratches or damage to the product.

1.2 Align the Wood Dowel of the Front Stretcher (C) with the mounting positions of the Side Frames (B) and affix with the JCBC Bolts ③ + Spring Washers + Flat Washers using the Allen Wrench ②.

1.3 Align the Wood Dowel of the Back Stretcher (D) with the mounting positions of the Side Frames (B) affix with the JCBC Bolts ③ + Spring Washers + Flat Washers using the Allen Wrench ②.

1.4 Align Front Rail & Back Rail (E) with the mounting position of the Side Frames (B).

DO NOT FULLY TIGHTEN THE BOLTS.

Step 2

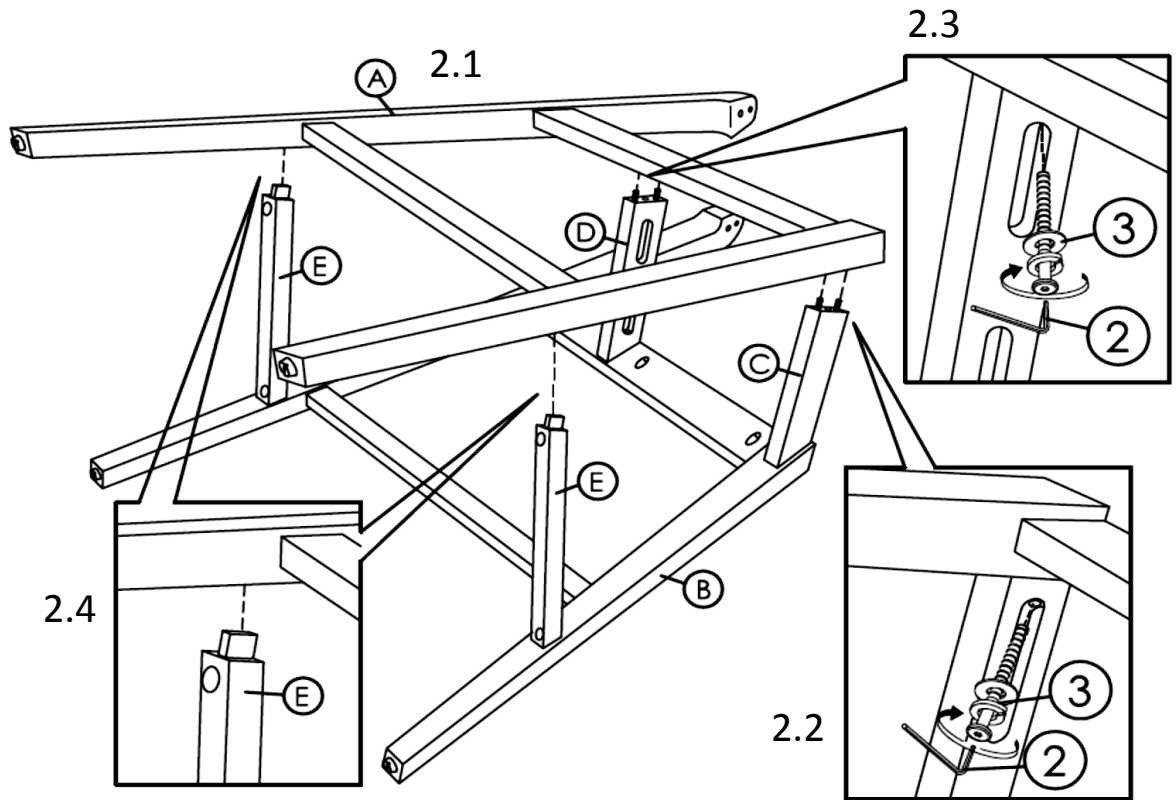

2.1 Place the Side Frame Right (A) with the mounting position of the Front Stretcher, Back Stretcher, Front & Back Rail.

2.2 Affix Front Stretcher (C) with the JCBC Bolts ③ + Spring Washers + Flat Washers using the Allen Wrench ②.

2.3 Affix Back Stretcher (D) with the JCBC Bolts ③ + Spring Washers + Flat Washers using the Allen Wrench ②.

2.4 Align Front Rail & Back Rail (E) with the mounting position of the Side Frames (A).

DO NOT FULLY TIGHTEN THE BOLTS.

Step 3

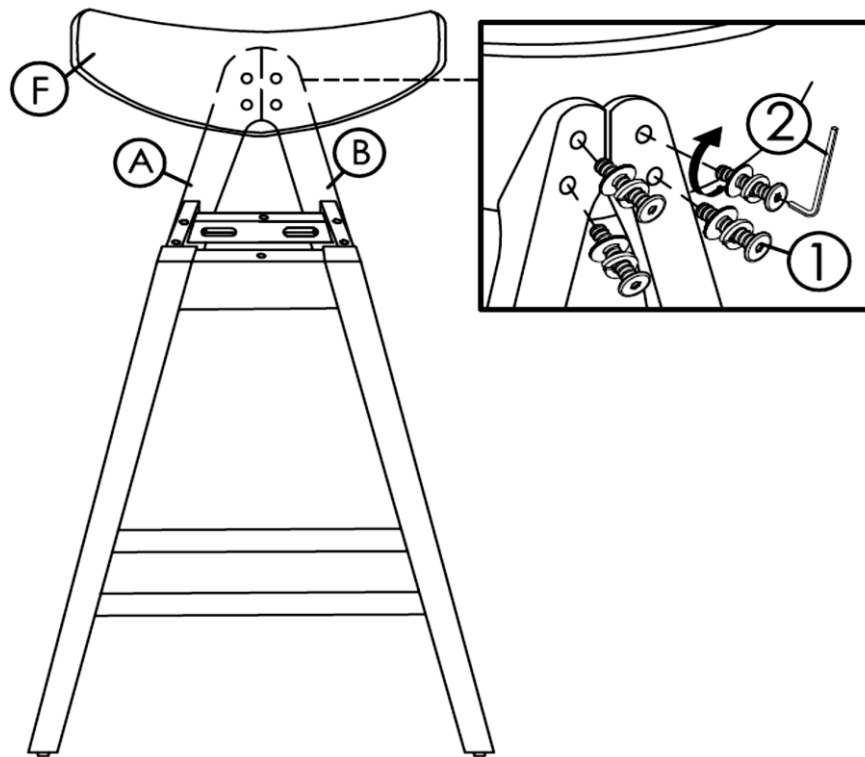

Place the Top Rest (F) on the back frame as shown above.
Then, affix the Top Rest (F) with the JCBC Bolts ① + Spring Washers + Flat Washers using the Allen Wrench ②.
DO NOT FULLY TIGHTEN THE BOLTS.

Step 4

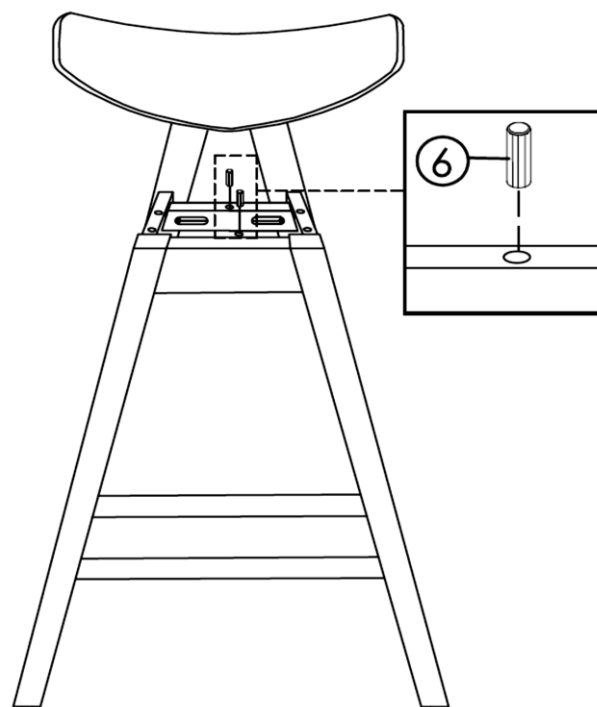

Place the Wood Dowel ⑥ on the top of the Front and Back Stretcher as shown above.

Step 5

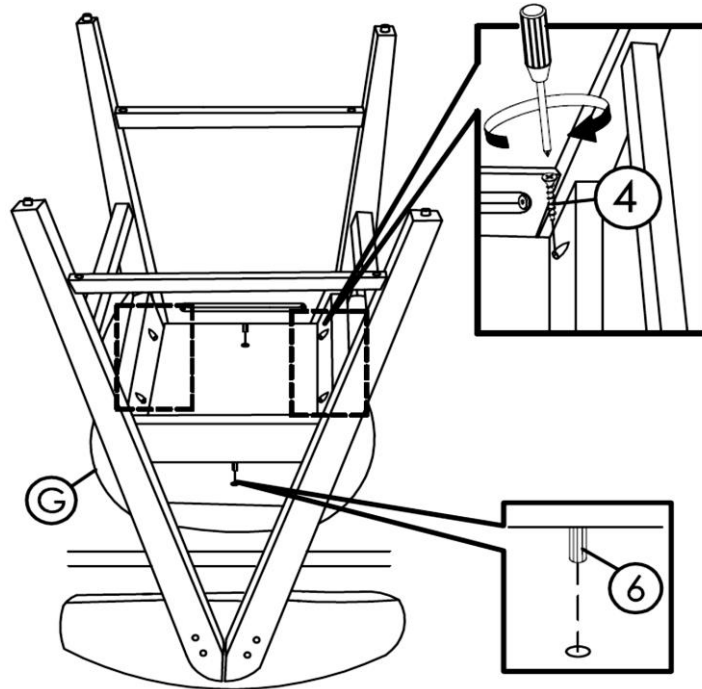

Place the Cushion Seat (G) on a table, then put the assembled stool parts in Step 4 to affix the Cushion Seat (G) as shown.

Align the Wood Dowel (6) into the tenon of the Cushion Seat (G) as shown above.

Then, affix the Cushion Seat (G) with the Screws (4) using a Screwdriver (not provided). **FULLY TIGHTEN THE SCREWS.**

Step 6

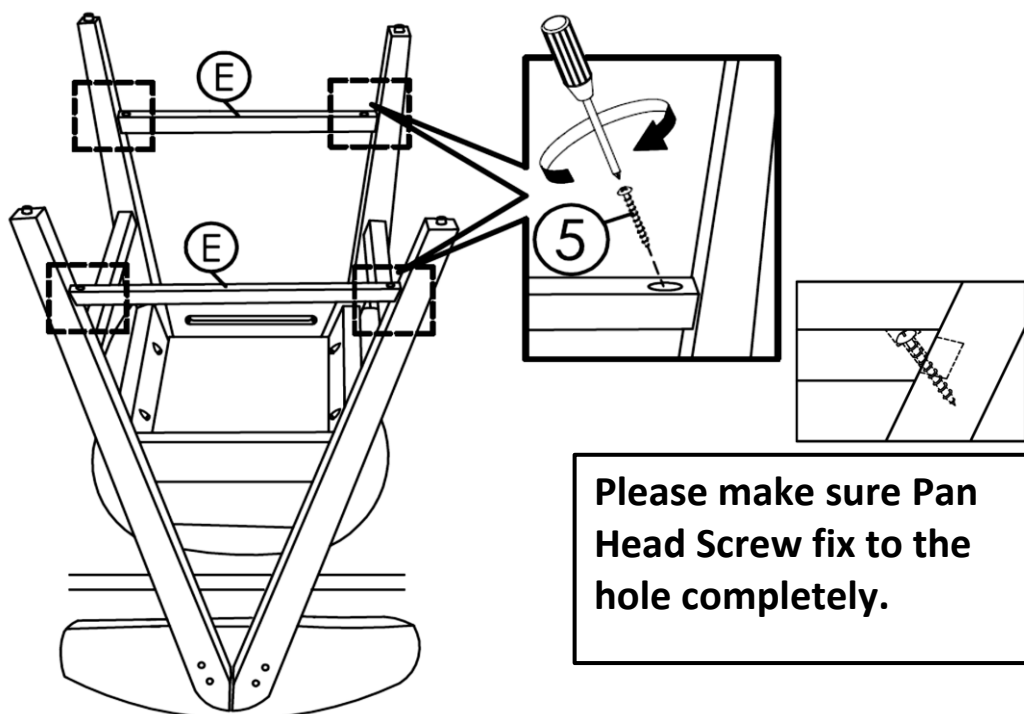

Then, fix the Front & Back Rail (E) with the Screws (5) using a Screwdriver (not provided). **FULLY TIGHTEN THE SCREWS.**

Step 7

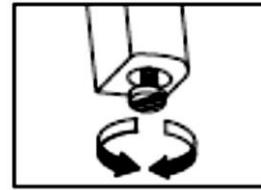
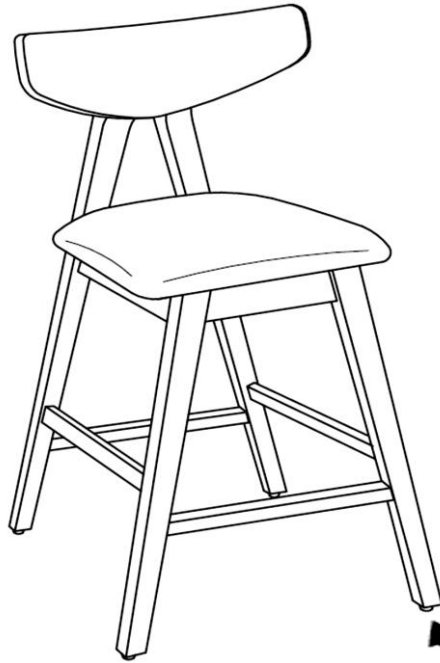

Turn clockwise or anti-clockwise to adjust leg leveller.

Turn clockwise or anti-clockwise to adjust leg leveller. The **Max** height during 0.25~0.8inch.

Step 8

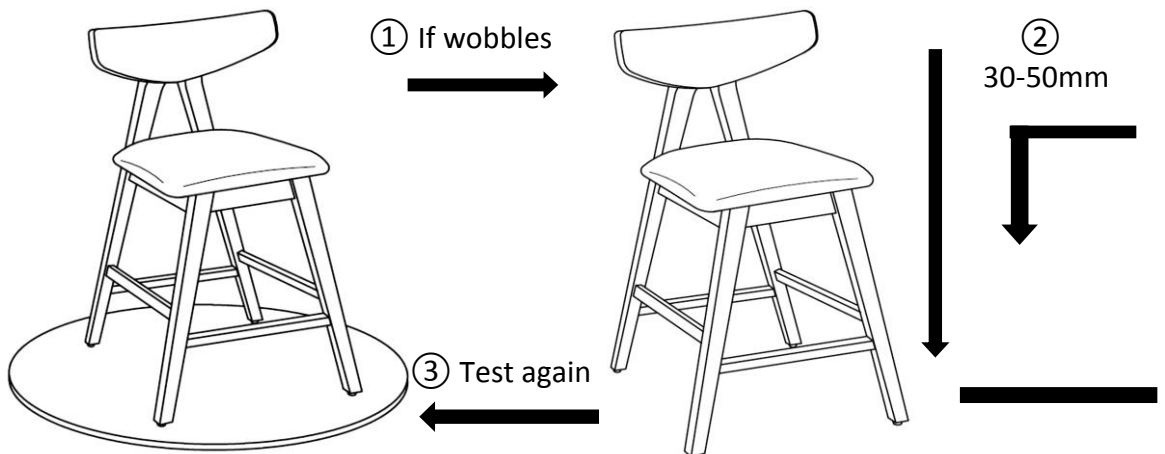

Place the Bar Stool on a level surface to check if it wobbles. If it wobbles, lift the bar stool some 30mm to 50mm from the ground, keep your feet and toes well away from the drop zone, and drop the bar stool freely and vertically with the four legs, hitting the ground at the same time. This drop test will help to ensure that all the bolts and gaps reach full alignment.

Test again for evenness on level surface.

If no wobbles are found, proceed to tighten all the bolts and screws.

Caution: When tightening the bolts and screws, tighten sequentially.

Do not tighten any screw or bolt fully and then move towards the next one, this would cause the frame to warp. If it still wobbles, loosen the bolts and screws and execute this same drop test.

If the bar stool is not stable it could lead to damage of the product.

Step 9



Inspect and make sure all parts are connected.

The Bar Stool is ready for use.

Caution: This bar stool can only be used on a flat, level surface.

Care & Maintenance



- Furniture may scratch floors. We recommend using furniture pads to protect your floors.



- Do not put hot items directly on furniture surface.



- Do not clean furniture with harsh cleansers or polish.



- Do not place furniture under direct sunlight.



- Do not place furniture near heating or cooling vents.



- Do not write on furniture without a padded barrier to protect the surface.



- Do not place furniture outside . For indoor use only.



- Not for commercial use. For residential use only.



- Stains may be removed with mild soap solution and damp cloth.



- Children should not climb or jump on the furniture.



- Dust and pick-up spills using a clean, non-colored, lint-free cloth.