

Storage Cabinet

WARNING

Serious or fatal injury may occur from unexpected assembly or use.

1. During the assembly process, keep all parts away from babies or children.
2. Always securely fix this product to the wall. Make sure the wall area to be drilled is free from hidden electrical wires, water and gas pipes.
3. Use of tip-over restraints may only reduce, but not eliminate the risk of tip-over.
4. Unless specially designed to accommodate, do not set heavy objects on top of this product.
5. Place the heaviest items on the lowest shelf.
6. Never allow children to climb or bang on drawers, doors or shelves.

WARNING



Children have died from furniture tipover. To reduce the risk of furniture tipover:

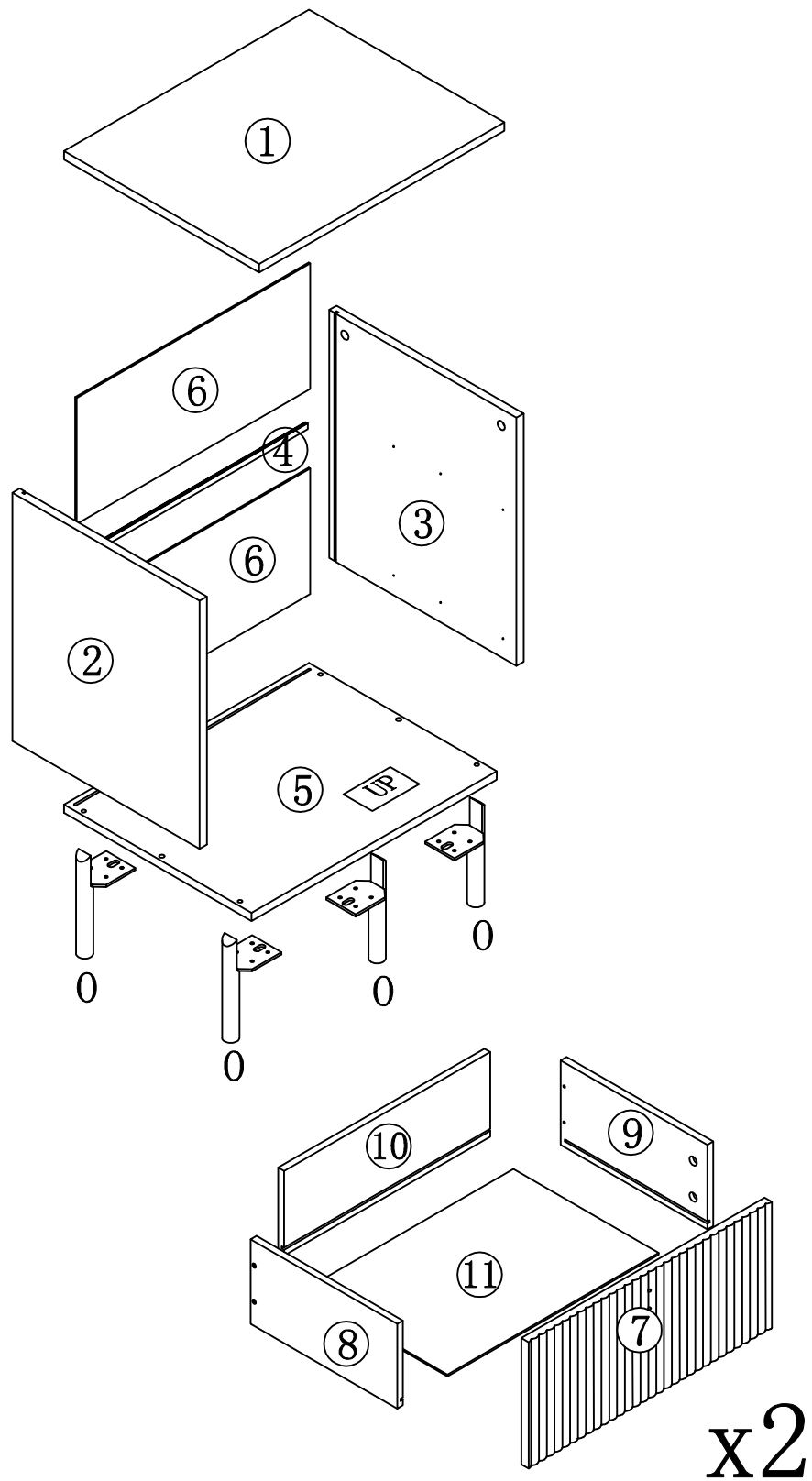

- **ALWAYS** install tipover restraint provided.
- **NEVER** put a TV on this product.
- **NEVER** allow children to stand, climb or hang on drawers, doors, or shelves.
- **NEVER** open more than one drawer at a time.
- **Place heaviest items in the lowest drawers.**

Parts List (EN) / Teile Liste (DE)



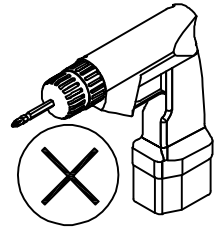
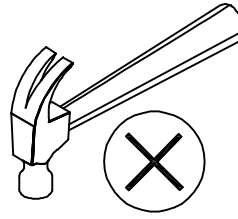
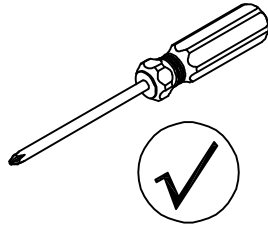
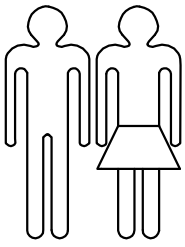

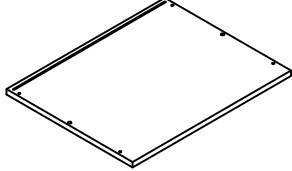
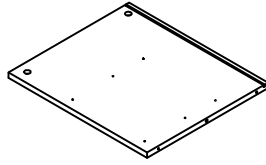
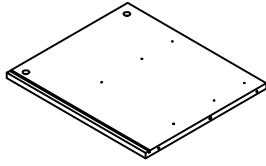

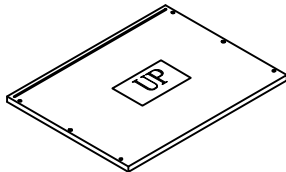
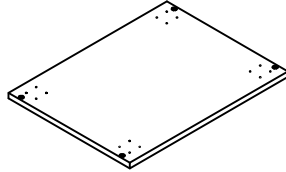
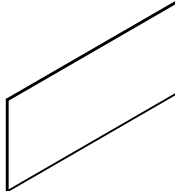
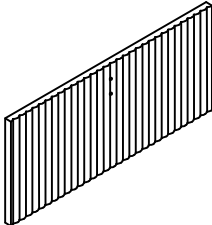
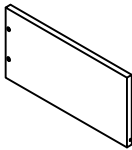
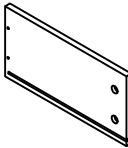
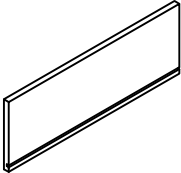
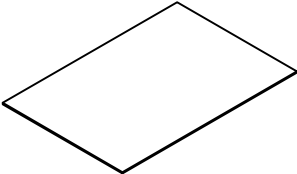



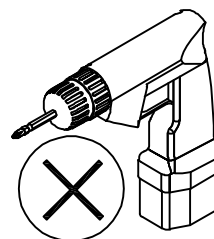
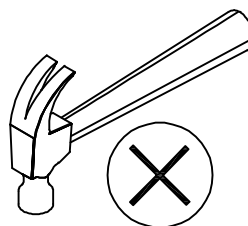
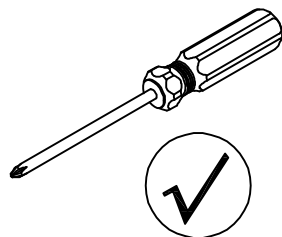
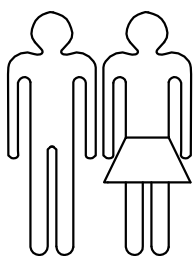

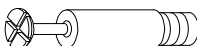
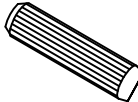

Parts List(EN)/Teile Liste(DE)

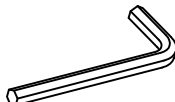

<p>①</p>  <p>500*400*15mm</p> <p>1PC</p>	<p>②</p>  <p>440*384*15mm</p> <p>1PC</p>
<p>③</p>  <p>440*384*15mm</p> <p>1PC</p>	<p>④</p>  <p>470mm</p> <p>1PC</p>
<p>⑤</p>  <p>500*384*15mm</p> <p>one side</p>  <p>the other side 1PC</p>	
<p>⑥</p>  <p>478*223*3mm</p> <p>2PCS</p>	<p>⑦</p>  <p>498*224*15mm</p> <p>2PCS</p>
<p>⑧</p>  <p>300*150*12mm</p> <p>2PCS</p>	<p>⑨</p>  <p>300*150*12mm</p> <p>2PCS</p>
<p>⑩</p>  <p>422*150*12mm</p> <p>2PCS</p>	<p>⑪</p>  <p>430*296*3mm</p> <p>2PCS</p>

Hardware List (EN) / Teile Liste (DE)

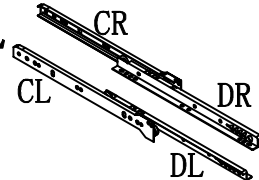
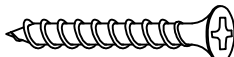

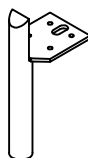
A  $\varnothing 15*9\text{mm}$ 12PCS	B  $\varnothing 6*29\text{mm}$ 12PCS	C  $\varnothing 8*30\text{mm}$ 4PCS	D  M4*20mm 4PCS
E  50*16*10mm 2PCS	F  $\varnothing 3*15\text{mm}$ 8PCS	G  $\varnothing 4*15\text{mm}$ 16PCS	H  $\varnothing 7*50\text{mm}$ 4PCS
I  14*13*9mm 8PCS	J  M4 1PC	K  $\varnothing 3*12\text{mm}$ 24PCS	L  12" 2PCS
M  $\varnothing 4*25\text{mm}$ 8PCS	N  $\varnothing 20\text{mm}$ 12PCS	O  135mm 4PCS	

Assembly (EN) /Montageschritte (DE)

CAM BOLT INSTALLATION AS BELOW:

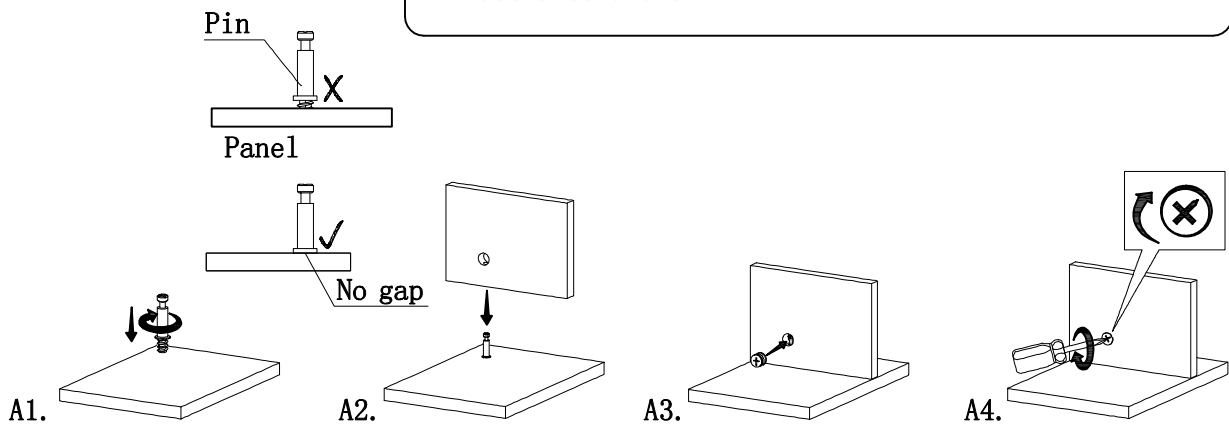
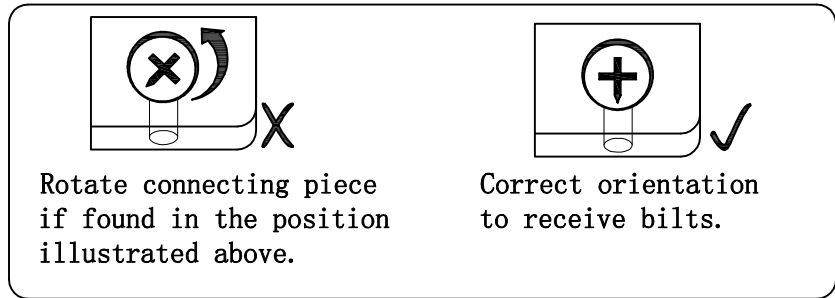
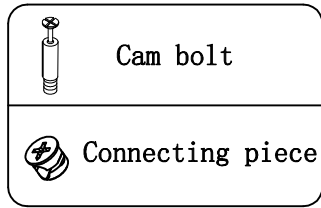

STEP 1

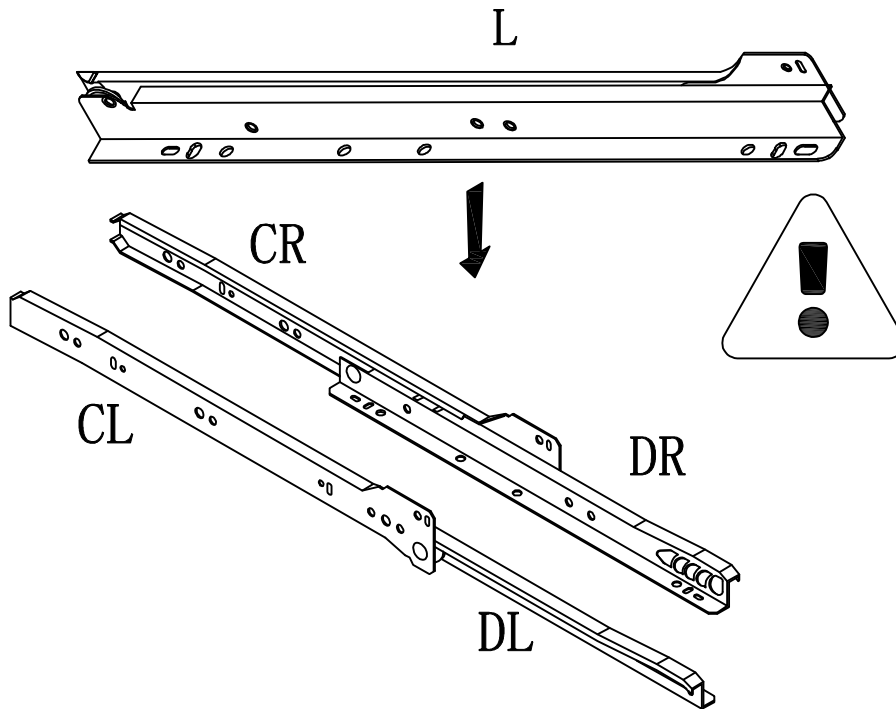

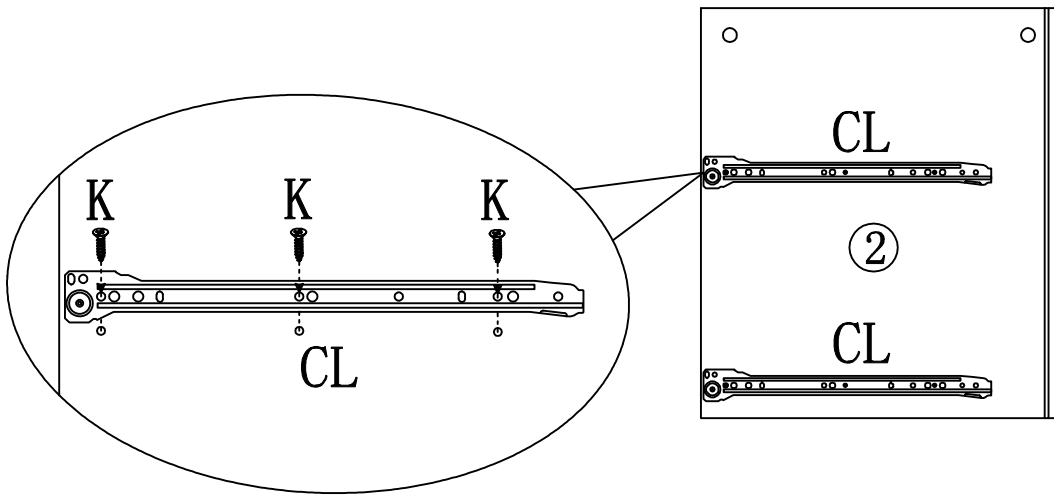

Assembly (EN) /Montageschritte (DE)

STEP 2



Lock the slides on to the plate according to the holes shown in the illustration.

	K * 6PCS
	CL * 2PCS

STEP 3

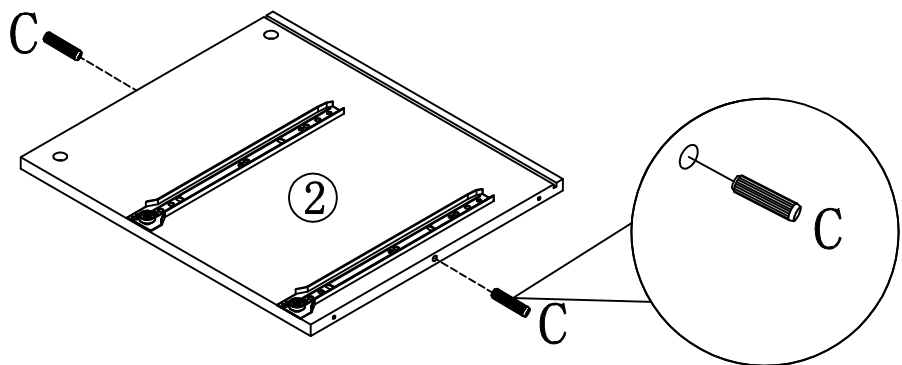



	C * 2PCS
---	----------

Assembly (EN) /Montageschritte (DE)

STEP 4

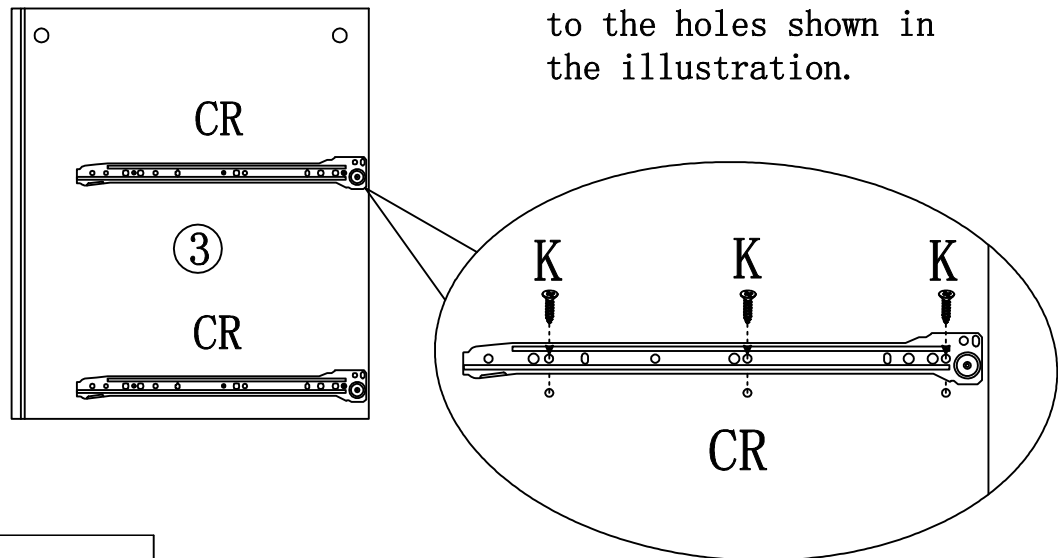
Lock the slides on to the plate according to the holes shown in the illustration.



	K * 6PCS
	CR * 2PCS

STEP 5

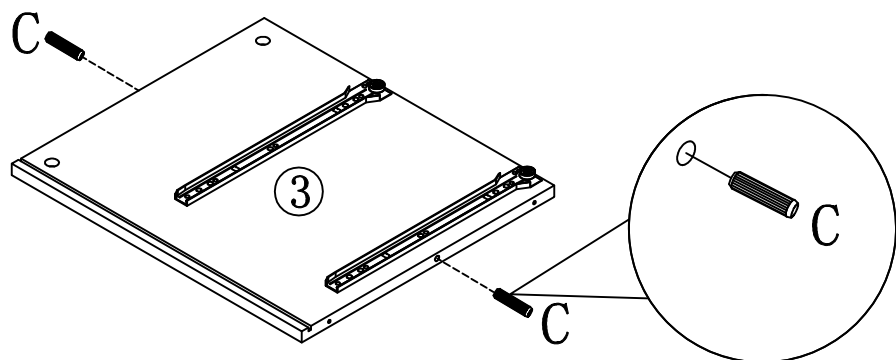

	C * 2PCS
---	----------

Assembly (EN) /Montageschritte (DE)

STEP 6

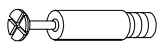
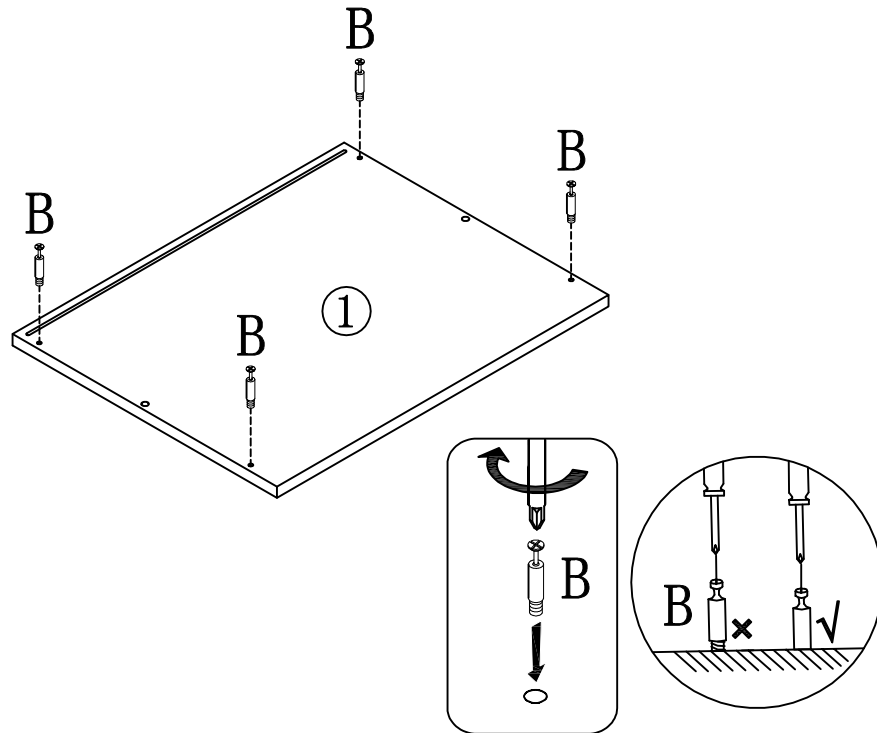

B * 4PCS

STEP 7

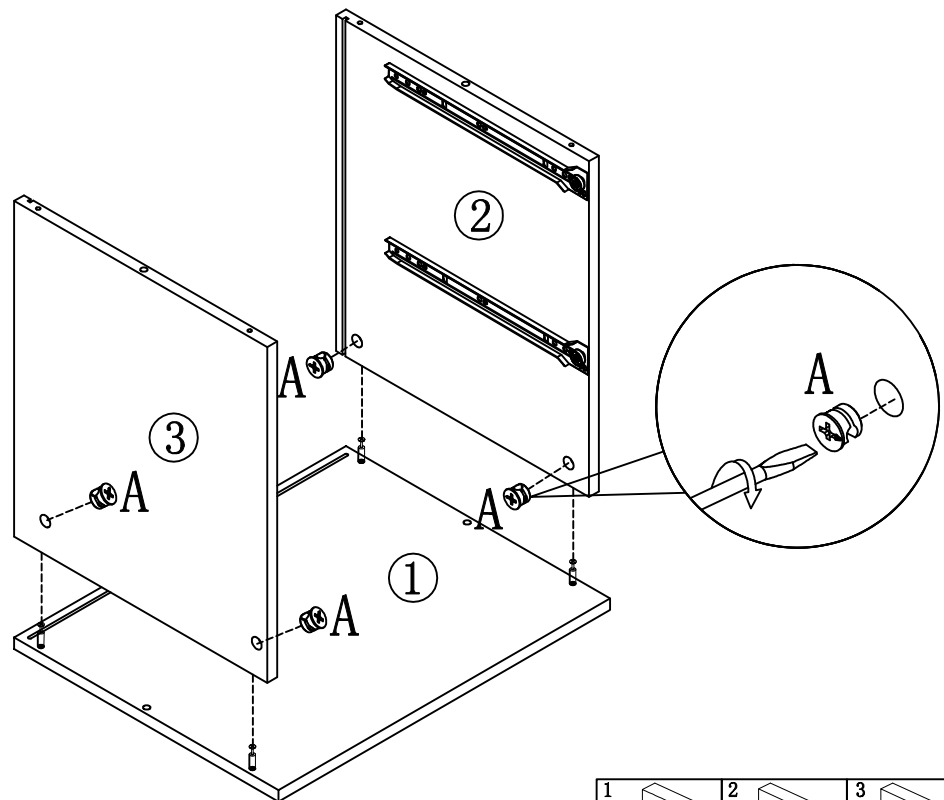

A * 4PCS

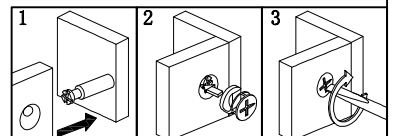

Assembly (EN) /Montageschritte (DE)

STEP 8

Thin back board needs to be inside the slot, otherwise blocks the opposite plate montage.

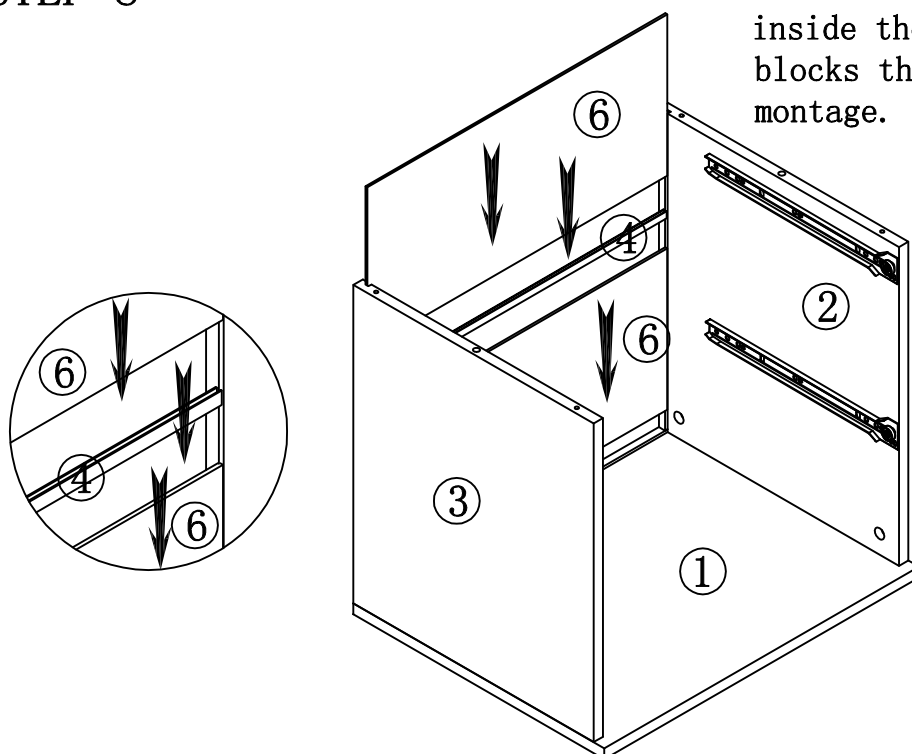

STEP 9

Thin back board needs to be inside the slot, otherwise blocks the opposite plate montage.

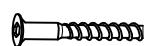
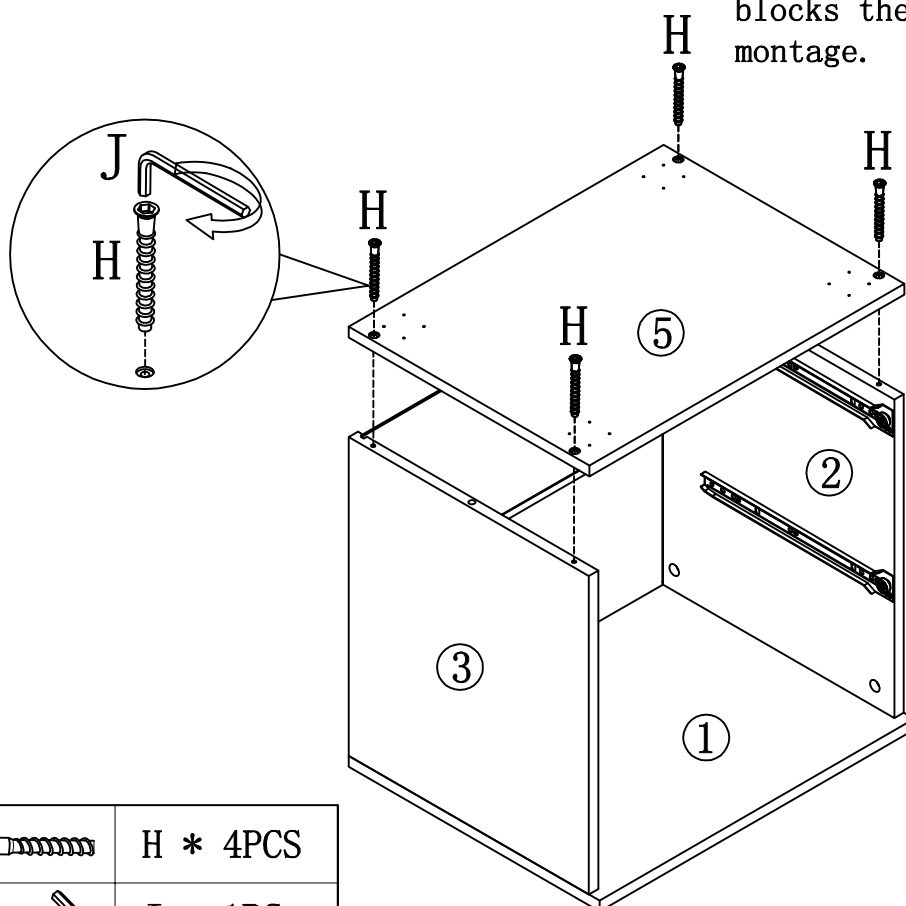

H * 4PCS



J * 1PC

Assembly (EN) /Montageschritte (DE)

STEP 10

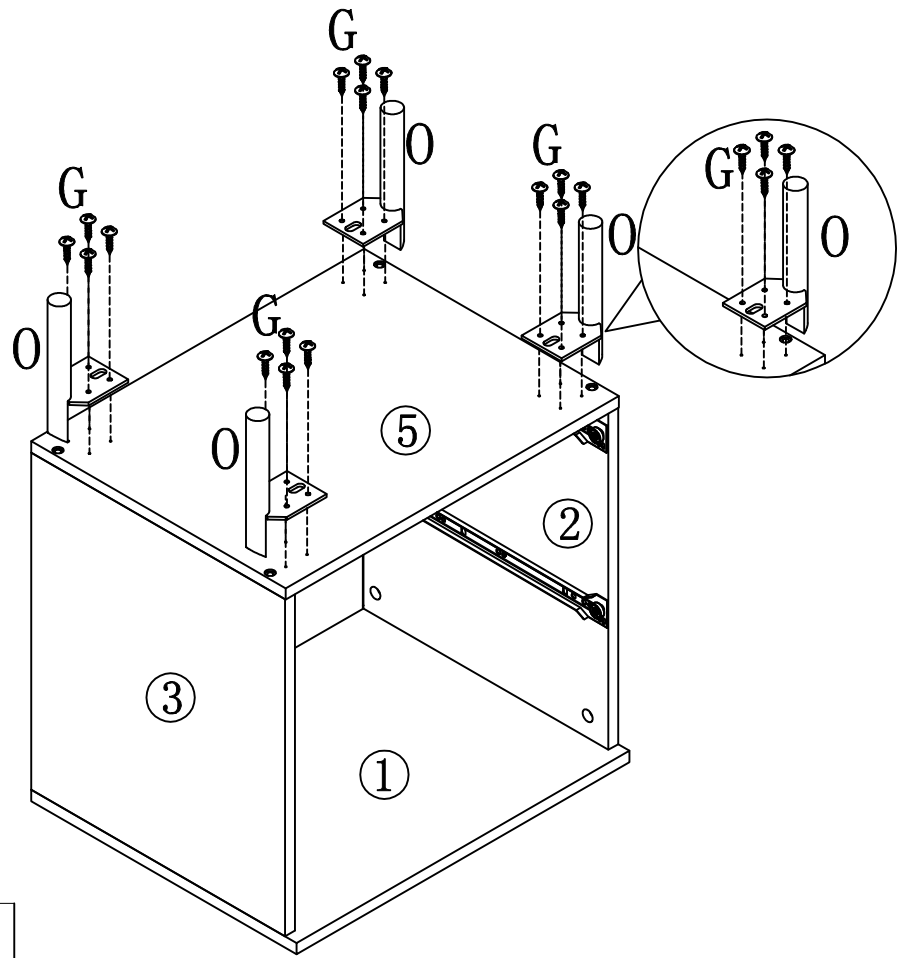

G * 16PCS



O * 4PCS

STEP 11

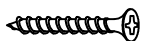
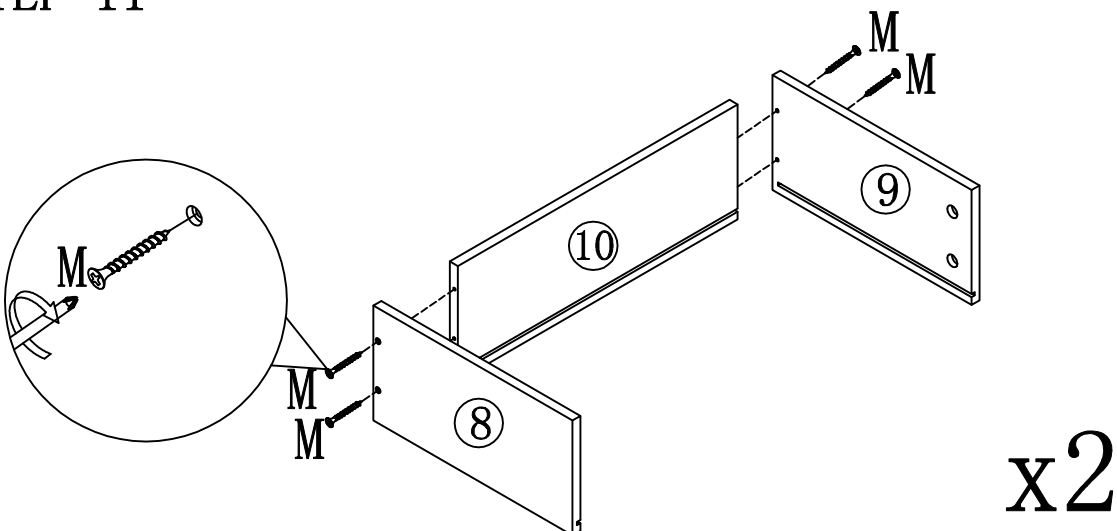

M * 8PCS

Assembly (EN) /Montageschritte (DE)

STEP 12

Thin back board needs to be inside the slot, otherwise blocks the opposite plate montage.

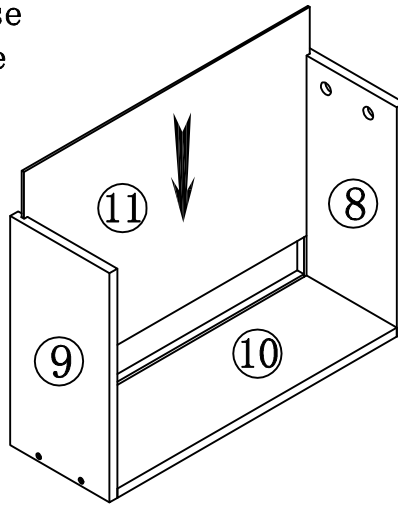

x2

STEP 13

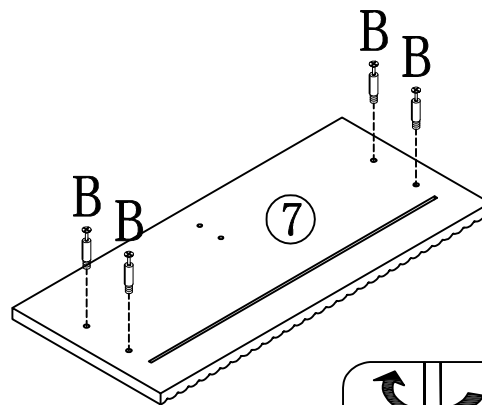

x2

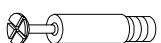
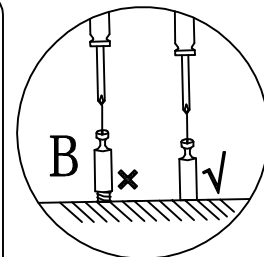
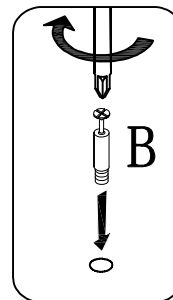

B * 8PCS

STEP 14

Thin back board needs to be inside the slot, otherwise blocks the opposite plate montage.

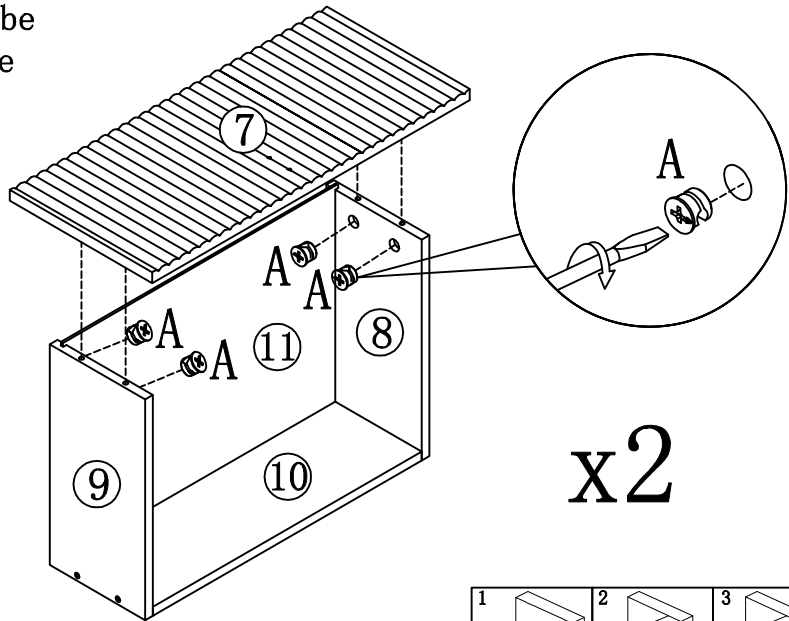

A * 8PCS

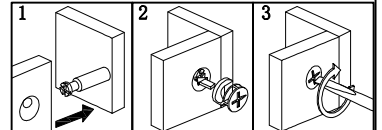

STEP 15

Lock the slides on to the plate according to the holes shown in the illustration.

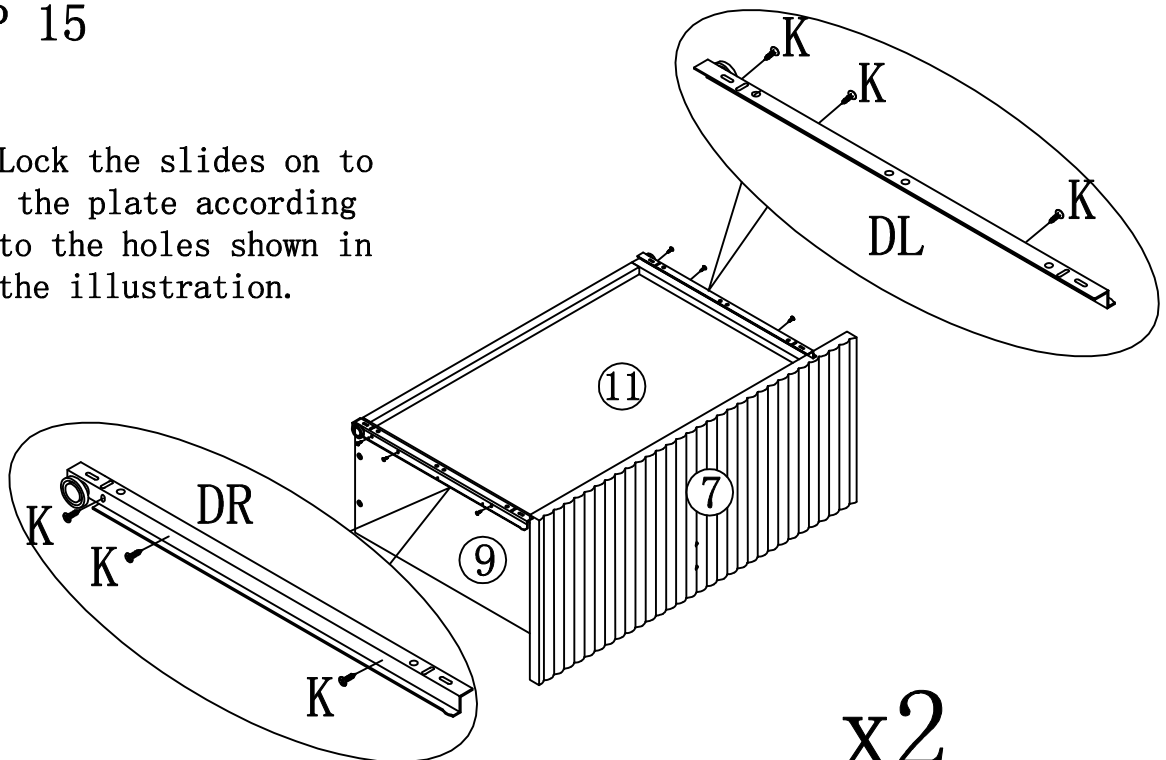

K * 12PCS



DL * 2PCS





DR * 2PCS

Assembly (EN) /Montageschritte (DE)

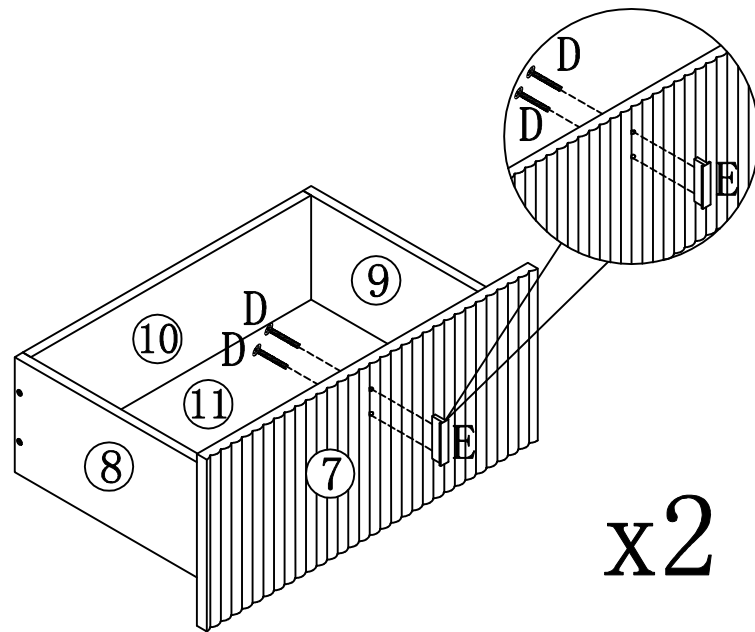
STEP 16



	D * 4PCS
	E * 2PCS

STEP 17

The rollers on both sides should be fully seated in the slides as shown.

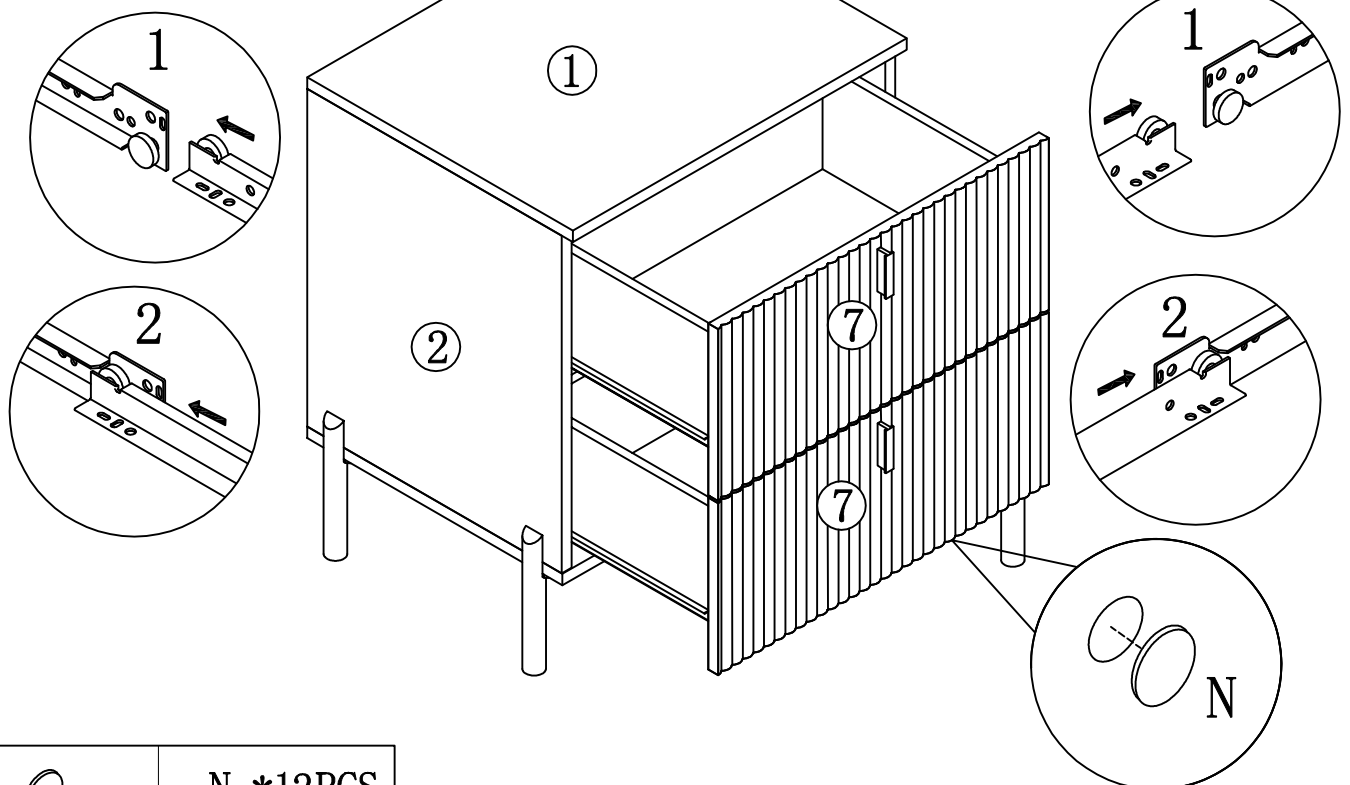



	N * 12PCS
---	-----------

Assembly (EN) /Montageschritte (DE)

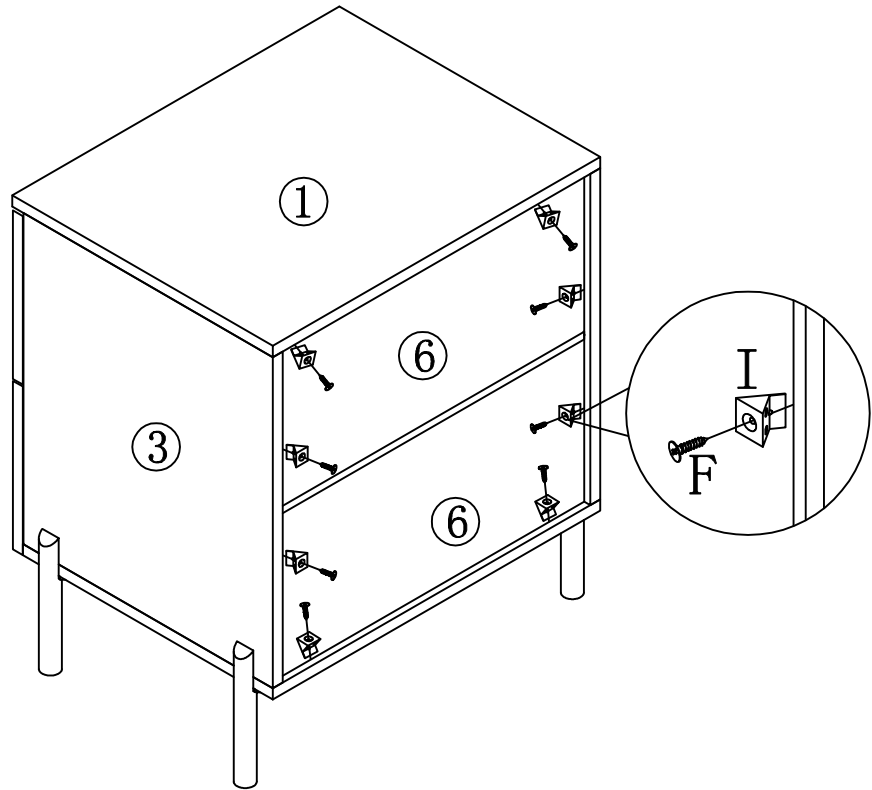
STEP 18



	F * 8PCS
	I * 8PCS

STEP 19

