



WALL DOME PR15



If you need assistance, please call 1-877-ENCLUME
Enclume Design Products
24 Colwell Street, Port Hadlock, WA 98339

Enclosed you will find everything needed for the assembly and use of your wall rack. Two people make assembly and installation easier. The parts and hardware included are:

Hardware included:

- 3 - 3/8" x 1/2" Button Head Screw
- 2 - 2" Lag Screw
- Toggler® Kit
- 1 - 7/32" Allen Wrench
- 2 - 1 1/2" Wood Screws

Components included:

- 1 - Half Round Base
- 3 - Arms
- 1 - Back Bar
- 1 - D-ring Axial
- 6 - Angled Pot Hooks
- 6 - Straight Pot Hooks

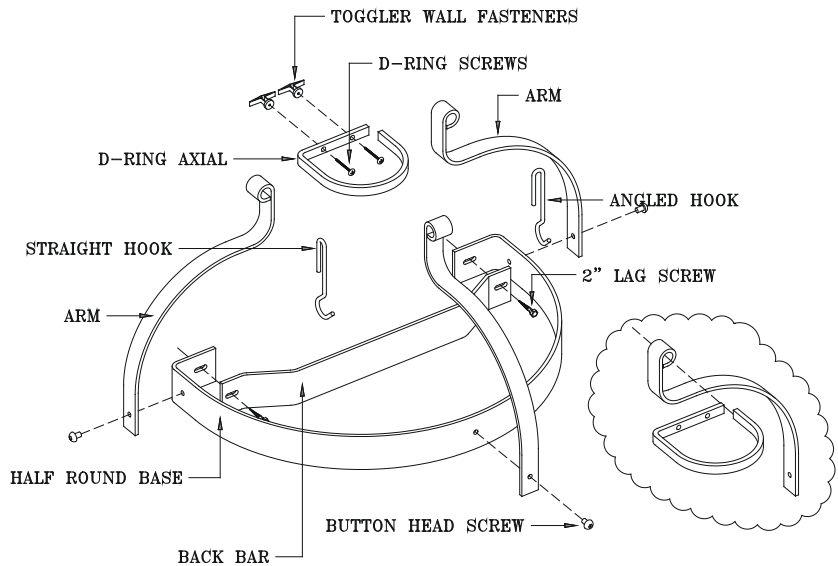

ASSEMBLY AND INSTALLATION INSTRUCTIONS

Rack Assembly

- 1) If your rack is plated it is best to keep the tissue on during installation to avoid fingerprinting.
- 2) Thread the D-ring through the roll at the top of each of the three arms.
- 3) Fasten the arms to the **outside** of the half round base with the three button head screws. Tighten the screws.
- 4) Hold the rack up to the wall, carefully measure and mark the wall. The base must go into the solid wood of wall studs or into a wooden wall. The D-ring attachment can be made with wall fasteners if a wooden support is unavailable.
- 5) Position the back bar on the inside of the half round base with the central curve outward, away from the wall. Thread the lag screws through the back bar and the base and attach to the wall.
- 6) Attach the D-ring with the Toggles or screws as appropriate. If using the Toggles follow the instructions in the Toggle kit.
- 7) The 6 straight pot hooks are to be used on the back bar.

WARNING: It is important that your wall rack is assembled correctly. If the unit is assembled or used incorrectly, it could become unstable and collapse, possibly causing injury.

LIMITED WARRANTY: This product is warranted to be free of material defects, other than that from normal use, for a period of five years from the date of purchase. Customer's exclusive remedy shall be the repair or replacement of the defective product and shall be subject to the following conditions: (1) notice of any defect is received by Enclume within the warranty period and (2) customer returns the defective product to Enclume Design Products, 24 Colwell St., Port Hadlock, WA 98339, postage prepaid within 20 days following a return authorization number (which may be obtained by telephoning the number at the top of this instructions) being provided to the customer by Enclume. There are no other warranties, expressed or implied. THERE ARE NO WARRANTIES OF MERCHANTABILITY OR FITNESS FOR A PARTICULAR PURPOSE. ENCLUME SPECIFICALLY DISCLAIMS ANY AND ALL INCIDENTAL OR CONSEQUENTIAL DAMAGES ARISING OUT OF THE PURCHASE OR USE OF ENCLUME'S PRODUCTS.