

ASSEMBLY INSTRUCTIONS

Item No : D1078-11





REX 48" ROUND DINING TABLE

Thank you for purchasing this quality product. Be sure to check all packing materials carefully for small parts, which may have come loose inside the carton during shipment. Identify and count all items and compare with the parts list and/or hardware list shown below.

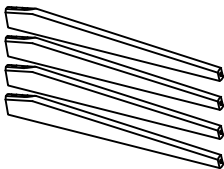
Cautions :

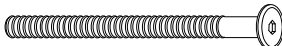
- (1) Do not fully-tighten the nuts or bolts until all nuts and bolts are assembled.
(To avoid causing damages to the thread, do not over-tighten the nuts or bolts.)
- (2) Keep all hardware part out of reach of children.

PARTS LIST			
NO	DESCRIPTION	SKETCH	QTY
A	TABLE TOP		1 PC
B	TABLE LEG		4 PCS

HARDWARE LIST			
NO	DESCRIPTION	SKETCH	QTY
1	BOLT 5/16" x 3 3/16"		8 PCS
2	SPRING WASHER 5/16"		8 PCS
3	FLAT WASHER 5/16"		8 PCS
4	ALLEN KEY		1 PC

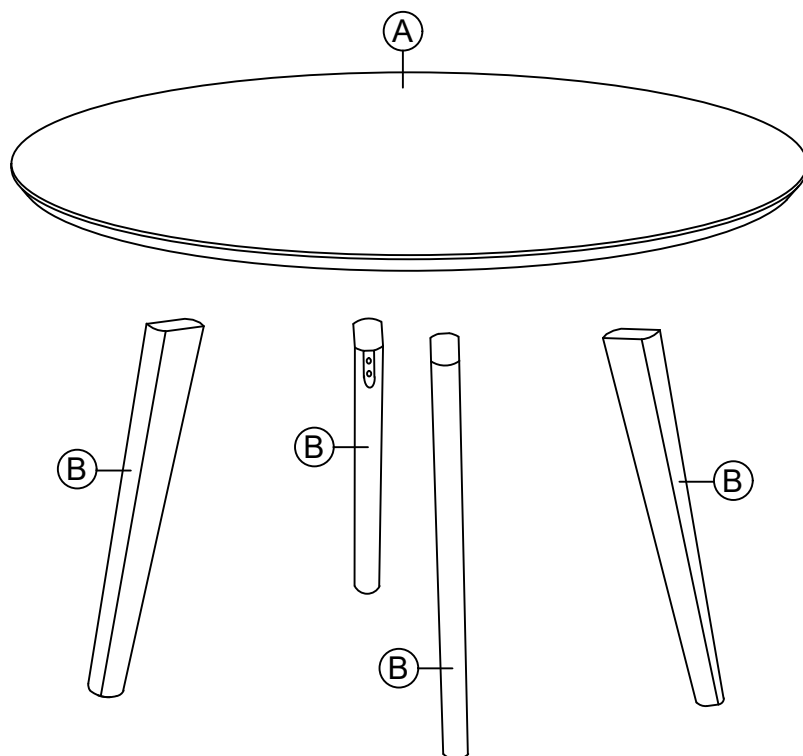
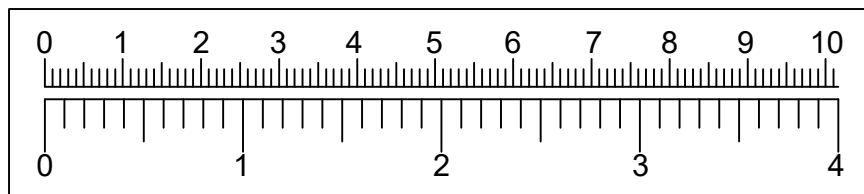

STEP 1 : Place the table top (A) upside down on a flat and clean surface. Assemble the table leg (B) to the table top (A) by using the Allen Key (4) and the hardware Bolt 5/16" x 3 3/16" (1), Spring washer (2) & Flat washer (3).

**Attention: DO NOT TIGHTEN THE BOLTS.

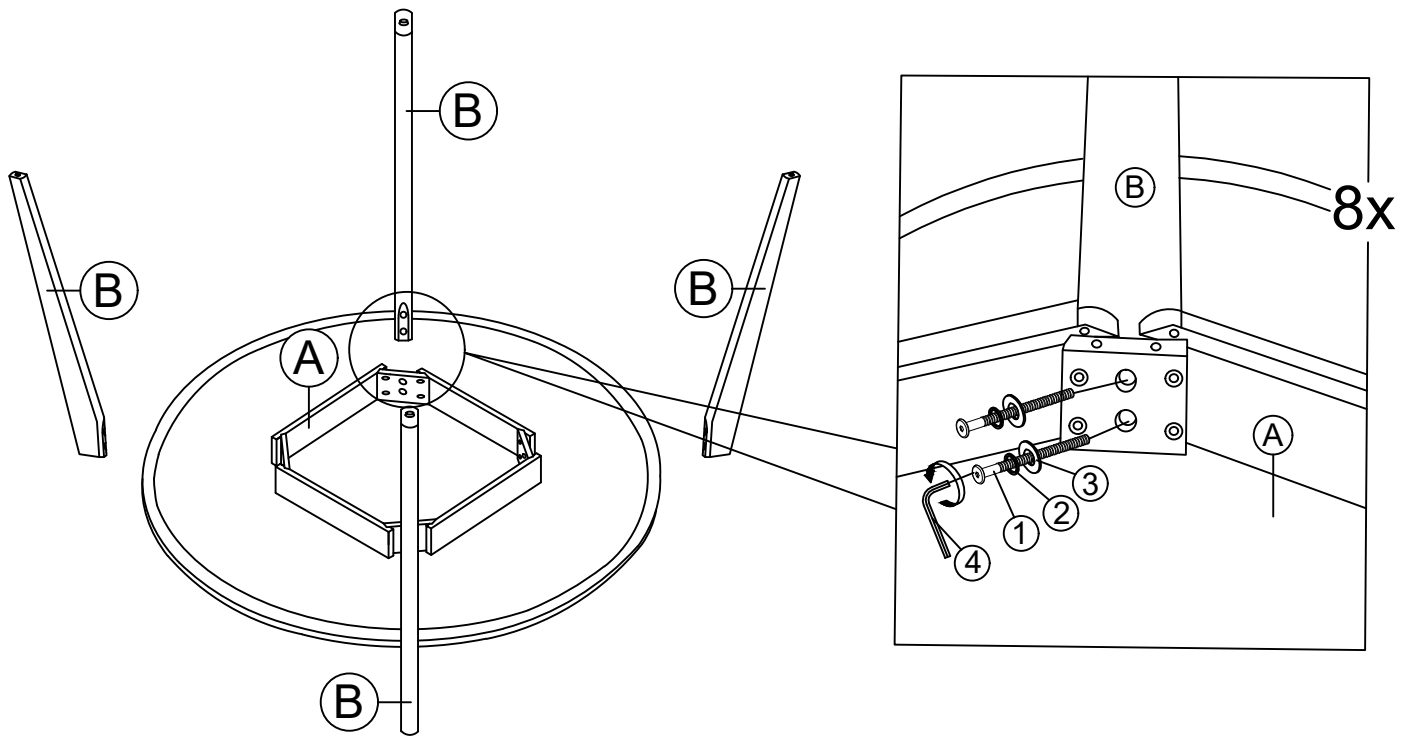

STEP 2 : To level the table, stand the table upright on a flat surface and tighten all the bolts by using Allen Key (4).

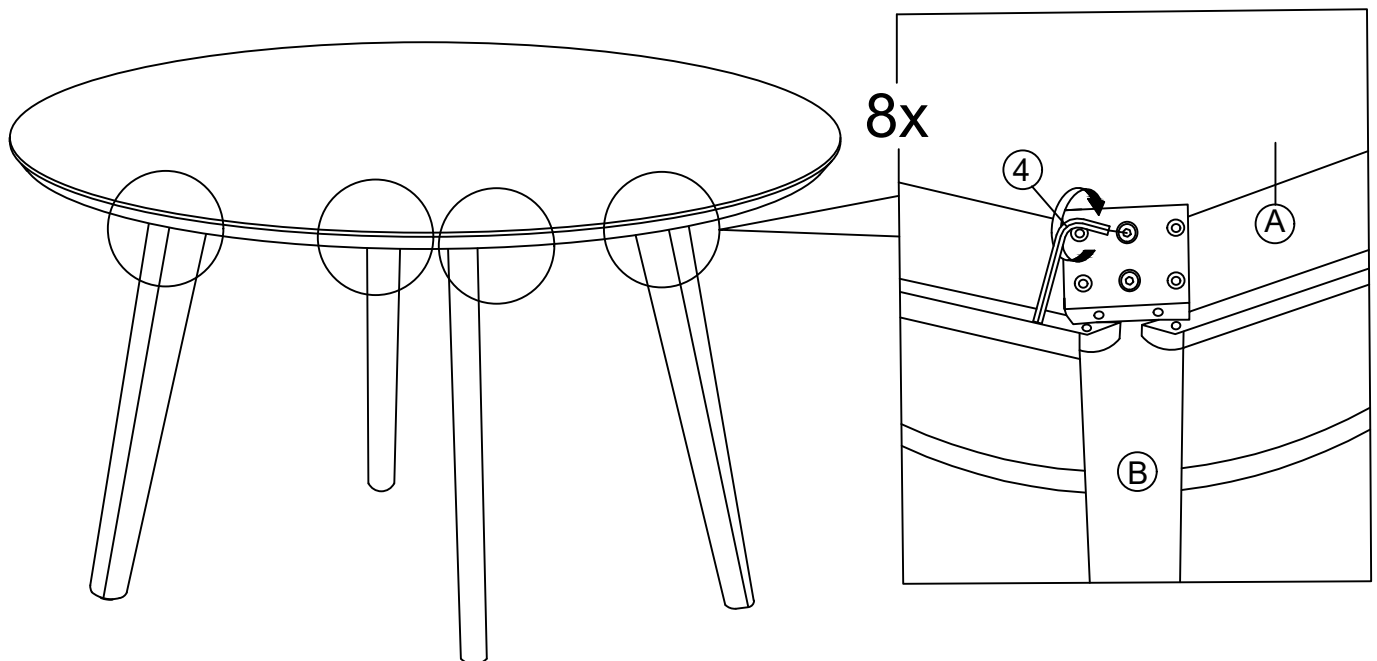



ASSEMBLY INSTRUCTIONS



Item No : D1078-20
REX OPEN BACK DINING CHAIR
(2PCS PER CARTON)

Thank you for purchasing this quality product. Be sure to check all packing materials carefully for small parts, which may have come loose inside the carton during shipment. Identify and count all items and compare with the parts list and/or hardware list shown below.

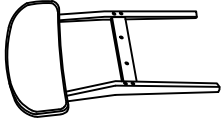
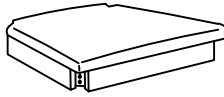
Cautions :

- (1) Do not fully-tighten the nut or nut bolts initially until all nuts or bolt is ready assembled.
 (To avoid causing damages to the thread, do not over-tighten the nuts or bolts.)
- (2) Keep all hardware part out of reach of children.

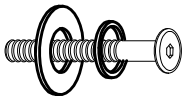
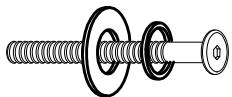
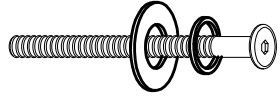
PARTS LIST			
NO	DESCRIPTION	SKETCH	QTY
A	CHAIR BACK		2 PCS
B	SEAT FRAME WITH CUSHION		2 PCS
C	FRONT LEG		4 PCS

HARDWARE LIST			
NO	DESCRIPTION	SKETCH	QTY
1	SHORT BOLT 1/4" X 1 3/8" WITH LOCK WASHER & WASHER		4 PCS
2	MEDIUM BOLT 1/4" X 2 3/8" WITH LOCK WASHER & WASHER		8 PCS
3	LONG BOLT 1/4" X 3 3/16" WITH LOCK WASHER & WASHER		8 PCS
4	ALLEN KEY		1 PC

WEIGHT CAPACITY	250 pounds (per seat)
-----------------	-----------------------

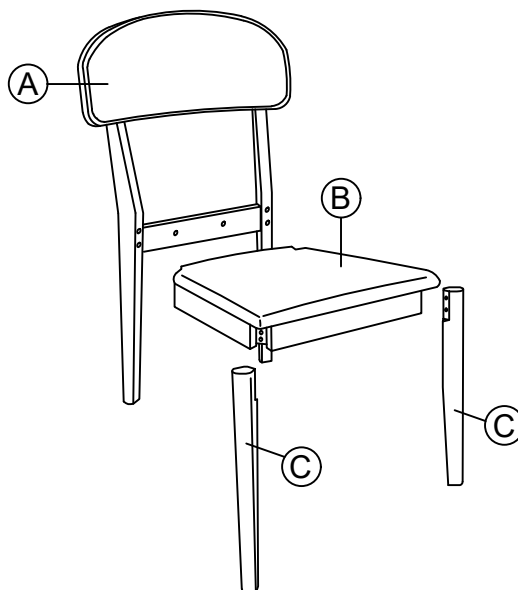
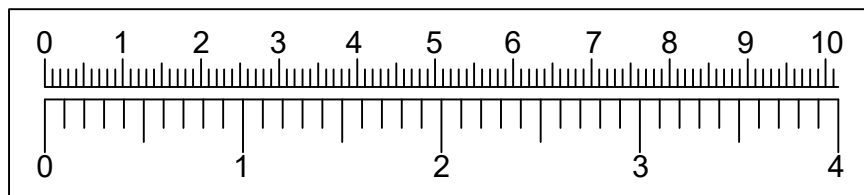

STEP 1 : Assemble the seat frame with cushion (B) with the chair back (A) using the Allen Key (4) with hardware (1).

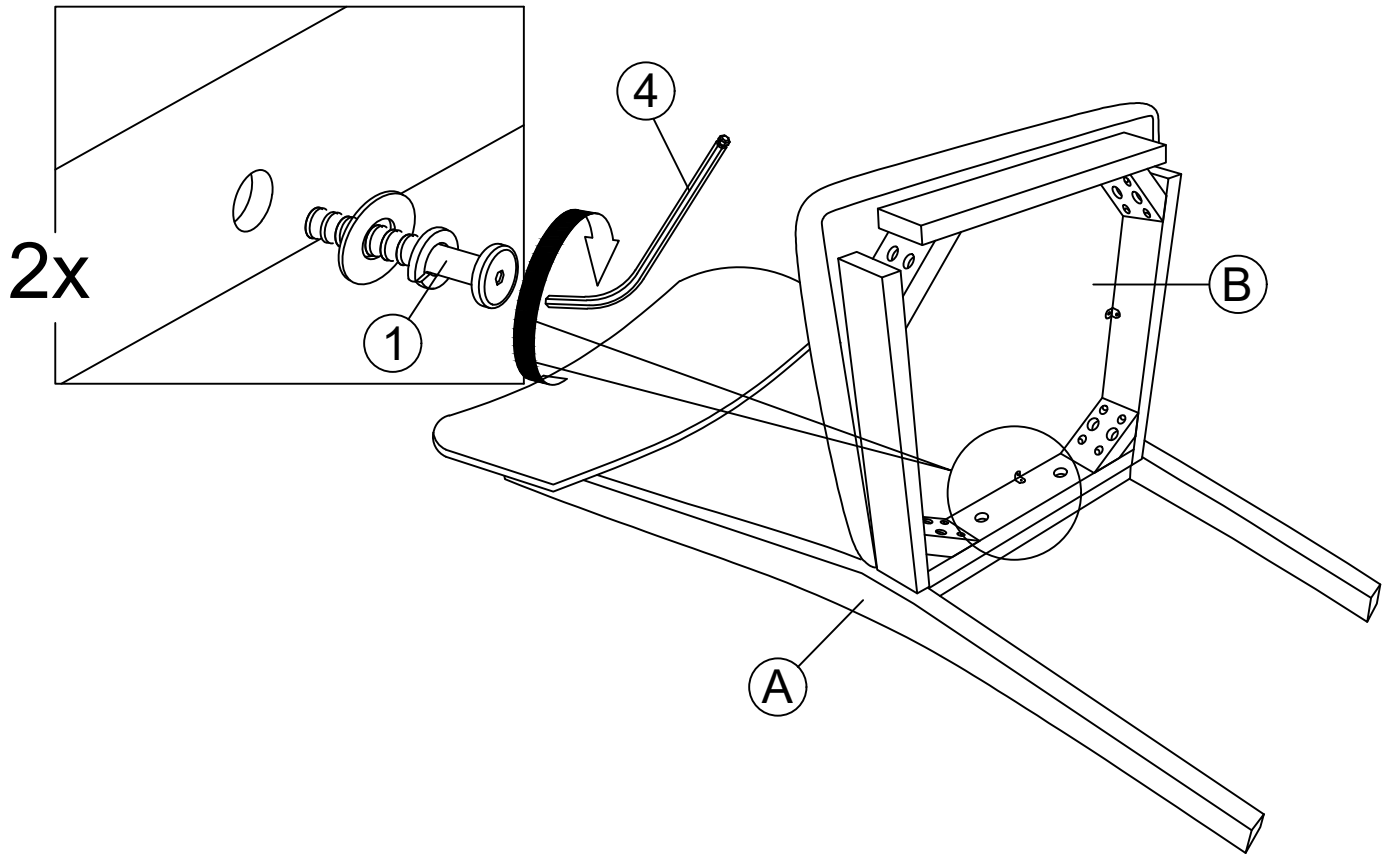

STEP 2 : Attach the seat frame with cushion (B) with the back legs of the chair back (A) by using the Allen Key (4) with hardware (3).
**Attention: DO NOT TIGHTEN THE BOLTS.

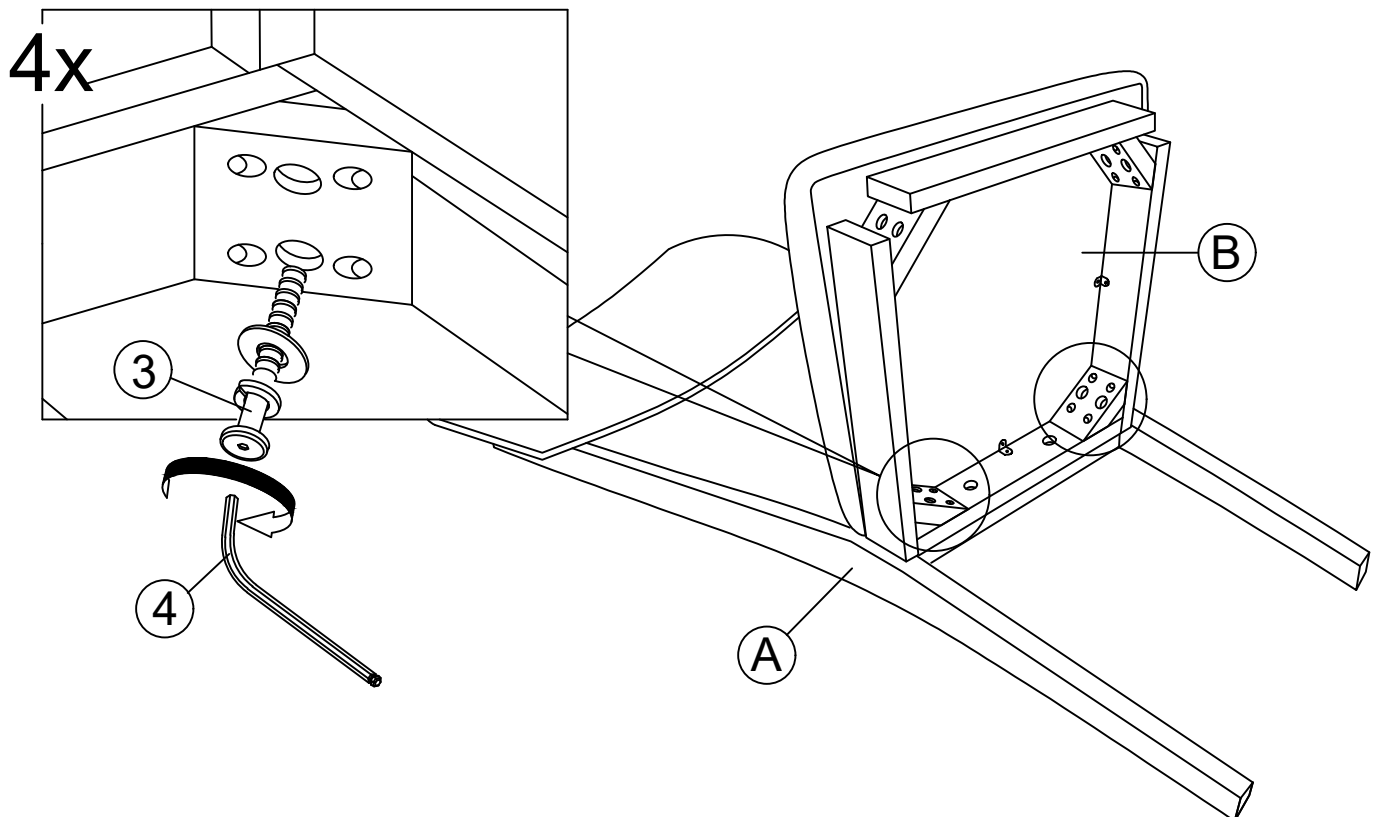

STEP 3 : Assemble the legs (C) with the seat frame with cushion (B) by using Allen key (4) with hardware (2).

****Attention: DO NOT TIGHTEN THE BOLTS.**

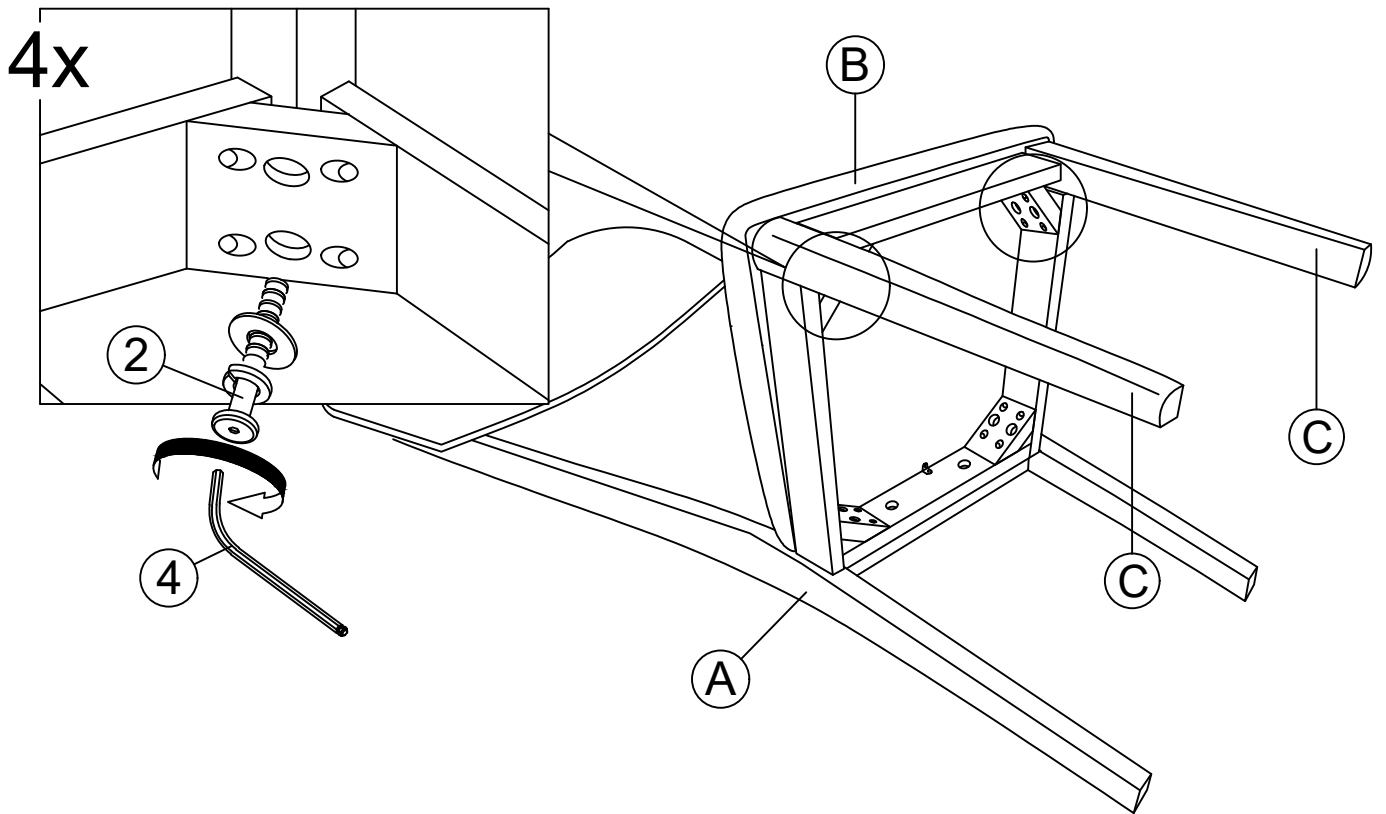

STEP 4 : To level the chair, stand the chair up on a flat surface and tighten all the bolts by using Allen Key (4).

