

ASSEMBLY INSTRUCTION

MODEL#WC005-2

Thank you for purchasing the quality product. Be sure to check all packing material carefully for small parts which may have come loose inside the carton during shipment. Separate, identify and count all parts and metal hardware. Compare with all parts list to be sure all parts are present. If any part(s) are missing or damaged, please contact your local furniture dealer. For efficient and speedy service, please indicate the mode number or code letter of part(s) needed.

*****Do not fully tighten screws until fully assembled*****

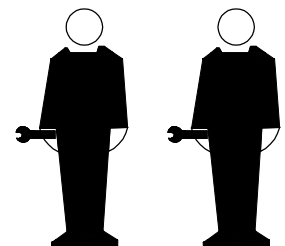
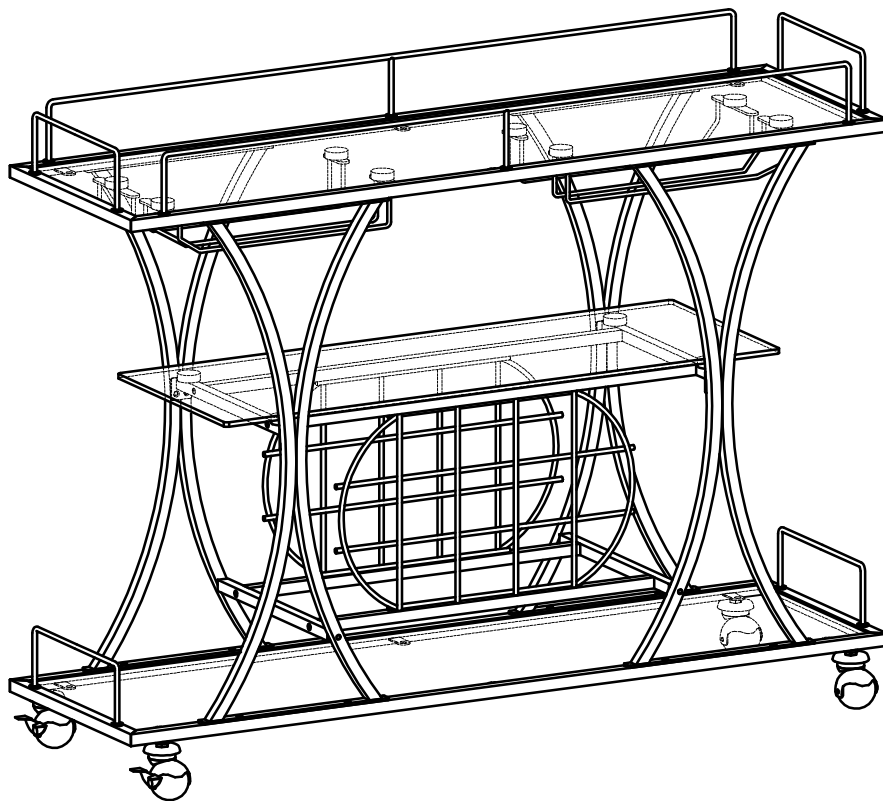

Attention:

*****Some number parts listed on the instruction sheet may not be in parts bag as they may already be assembled. Carefully check parts and packing materials prior to ordering replacements.**





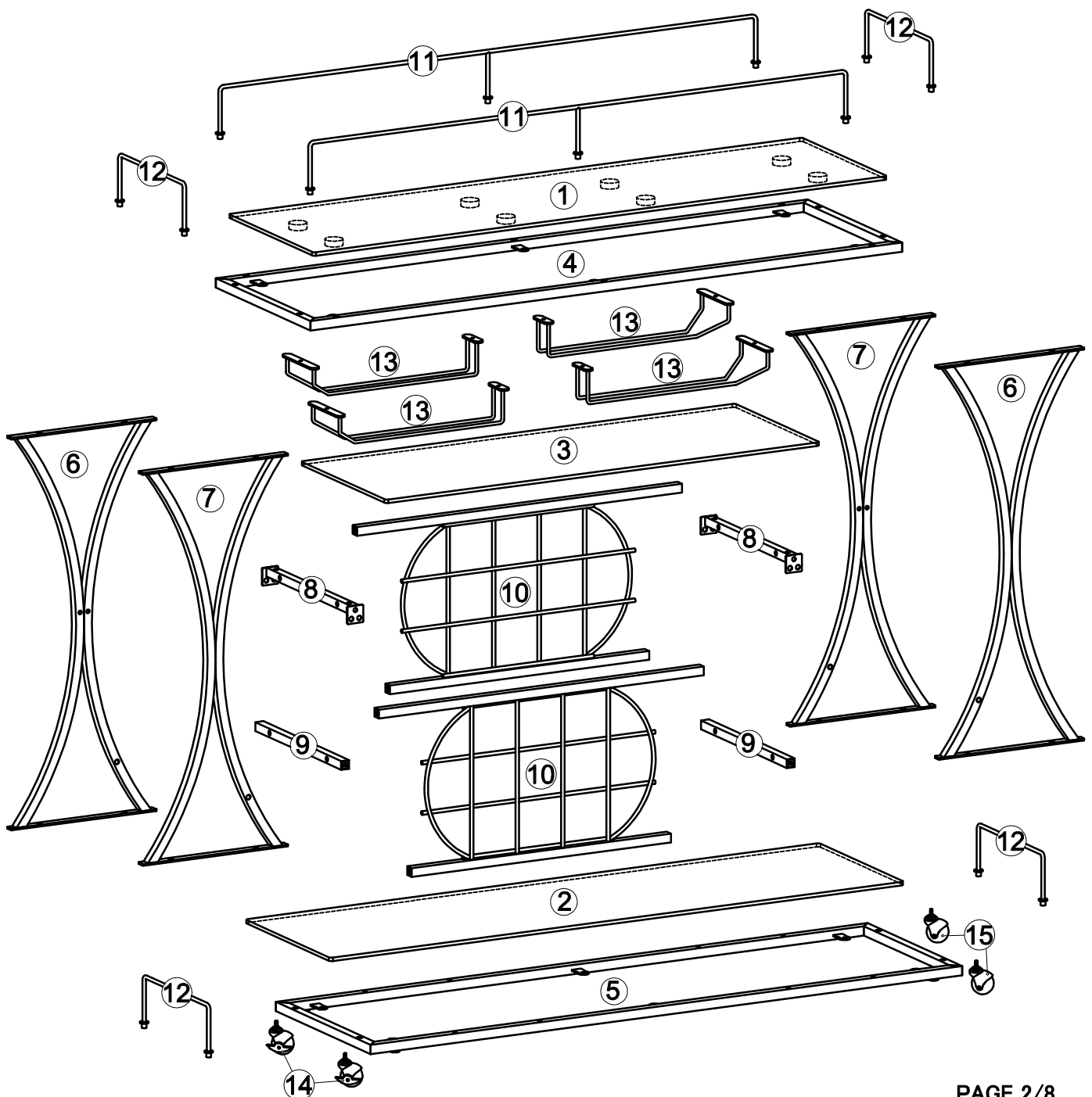

General Assembly Guidelines

- I. Ensure that all parts and hardware are available before beginning assembly.
- II. Follow each step carefully to ensure the proper assembly of this product.
- III. Two people are recommended for ease in the assembly of this product.
- IV. The three main types of hardware used to assemble this product are: wood dowels, screws and bolts.

COMPONENT PARTS



Hardware List

A		M6*8mm	Bolt	8 pcs
B		M6*15mm	Bolt	38 pcs
C		M6*22mm	Bolt	4 pcs
D		M6*25mm	Bolt	12 pcs
E		Ø20mm	Rubber suction cups	12 pcs
F		M4*55mm	Wrench	1 pc
G			Wrench	1 pc

Step 1

A x 8



M6x8mm

F x 1



M4x55mm

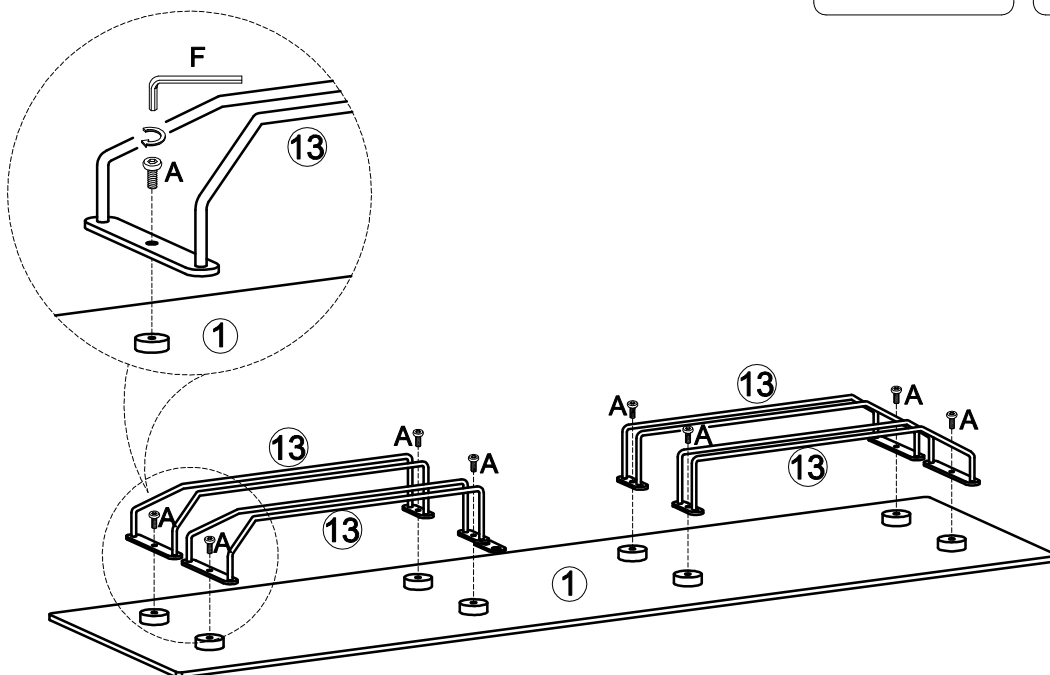

Step 2

B x 8



M6x15mm

F x 1



M4x55mm

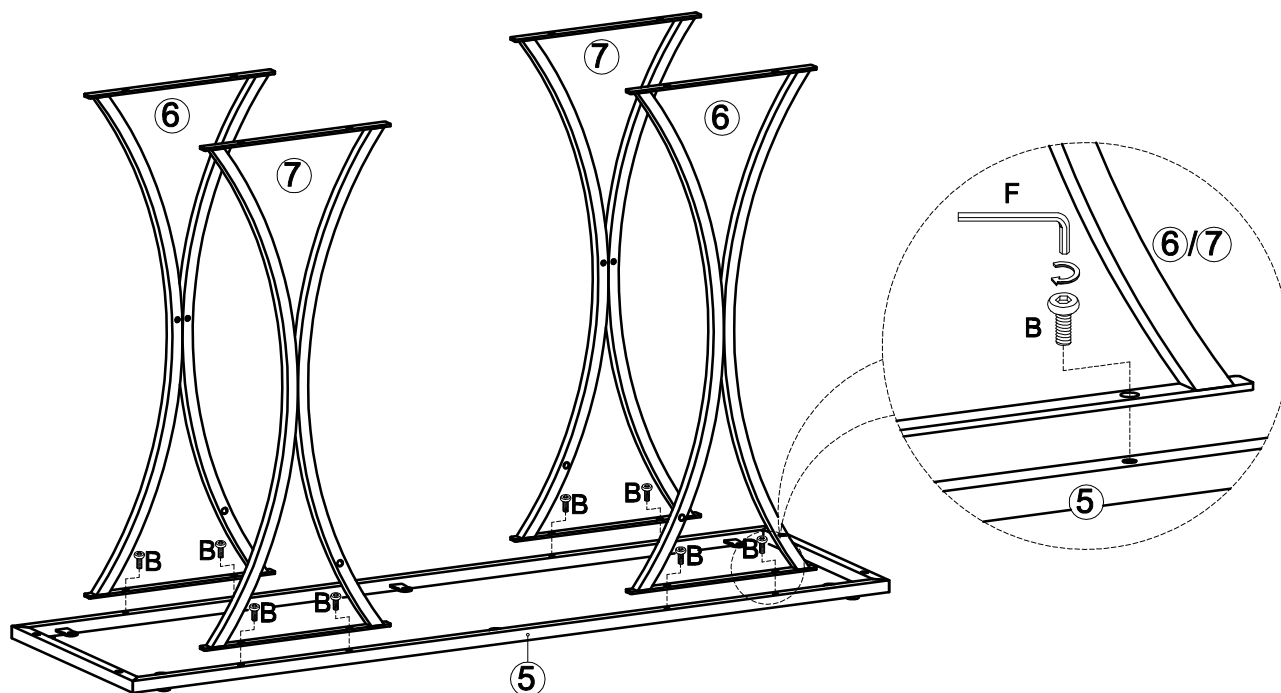

Step 3

B x 8



M6x15mm

D x 4

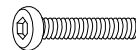

M6x25mm

F x 1



M4x55mm

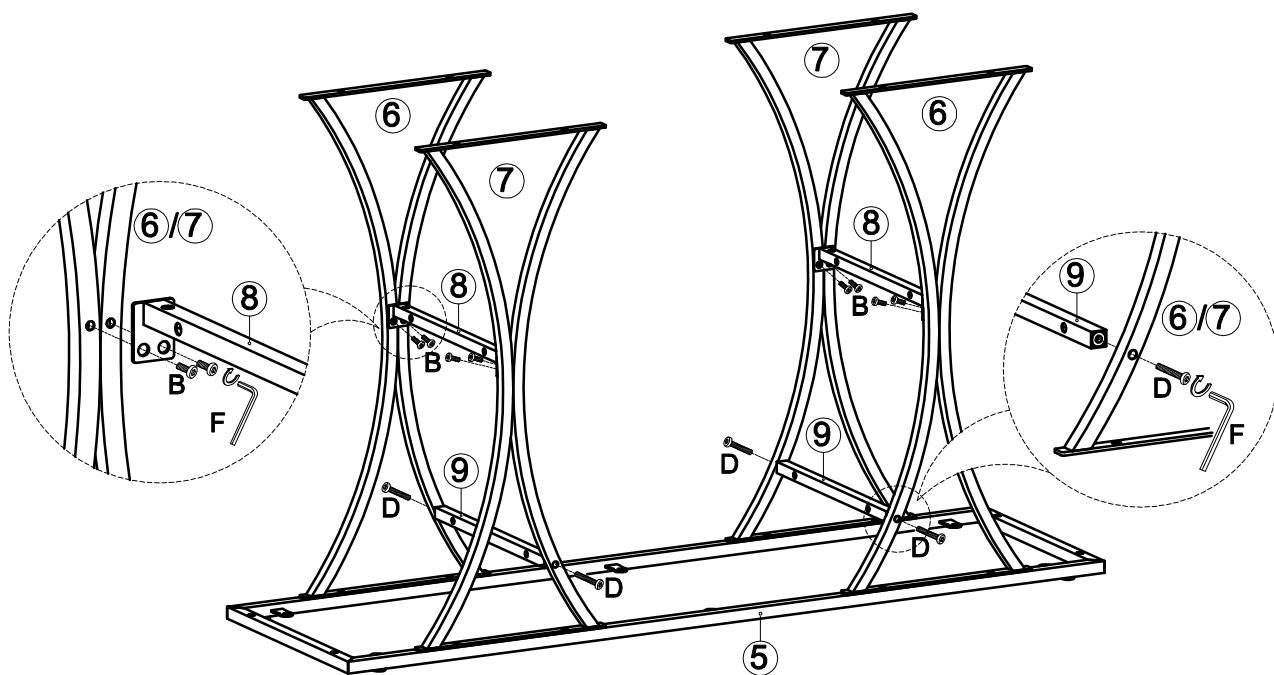

Step 4

D x 8



M6x25mm



F x 1

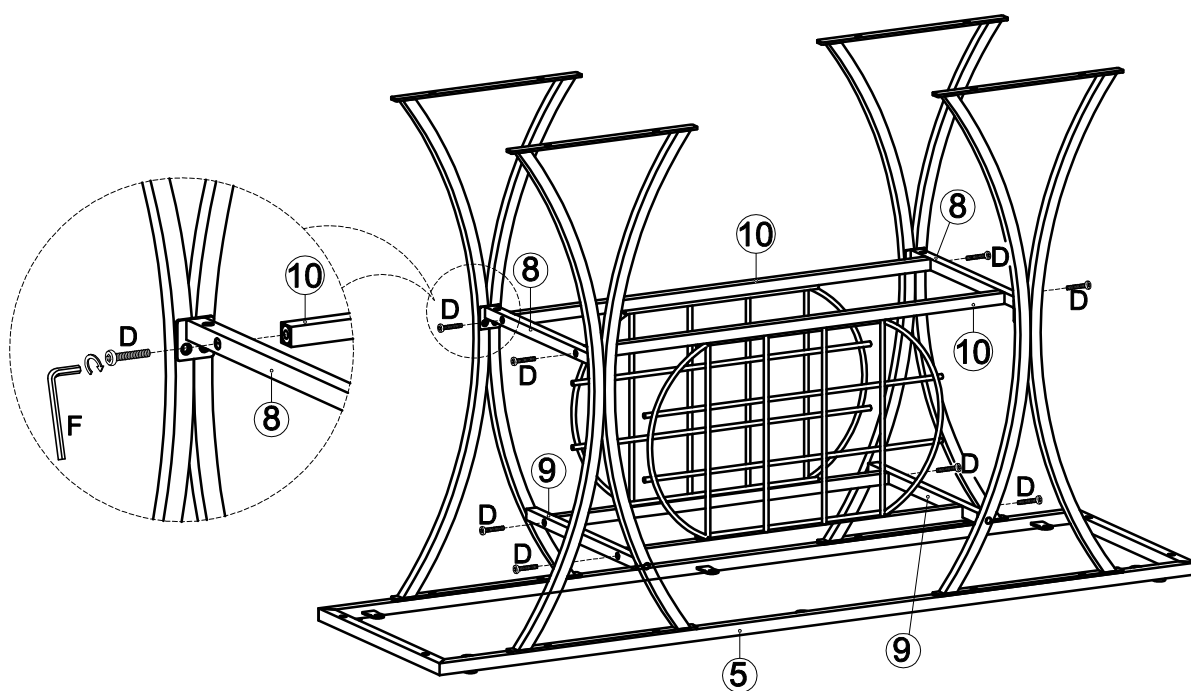

M4x55mm



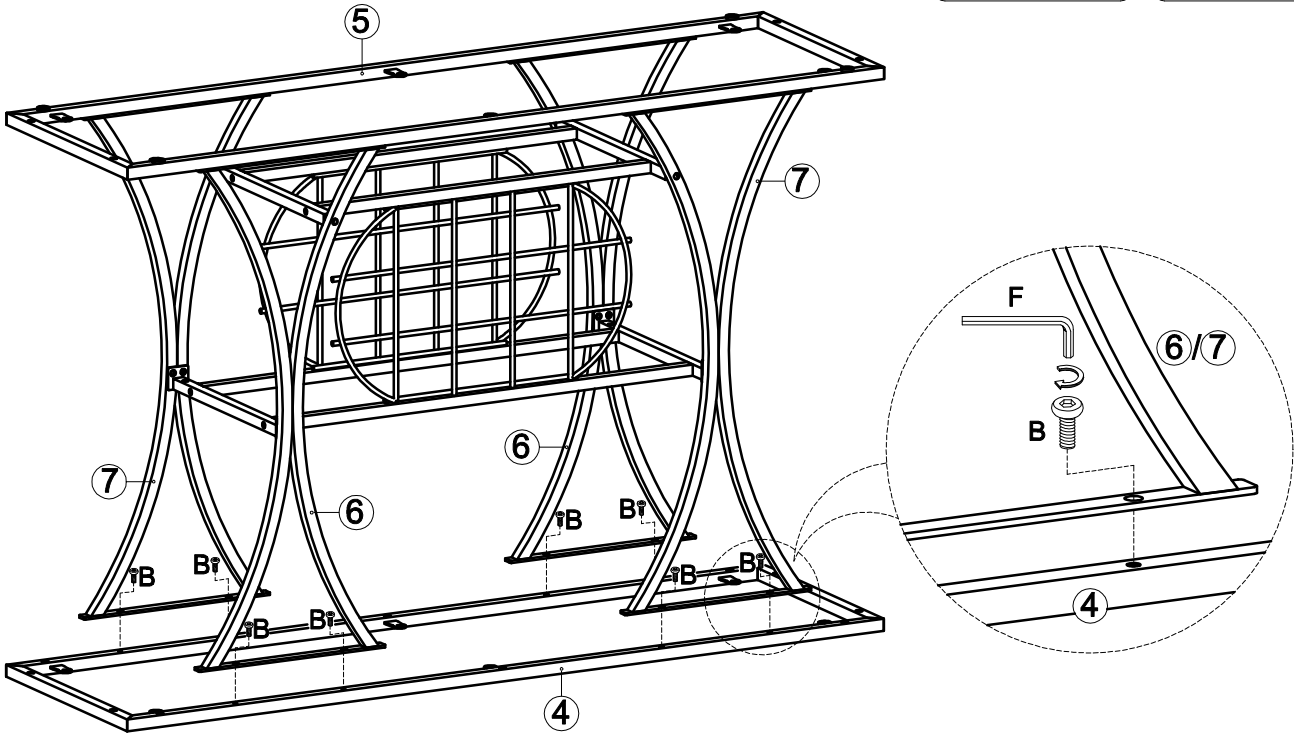

Step 5

B x 8	F x 1
	
M6x15mm	M4x55mm



Step 6

C x 4	F x 1	G x 1
		
M6x22mm	M4x55mm	

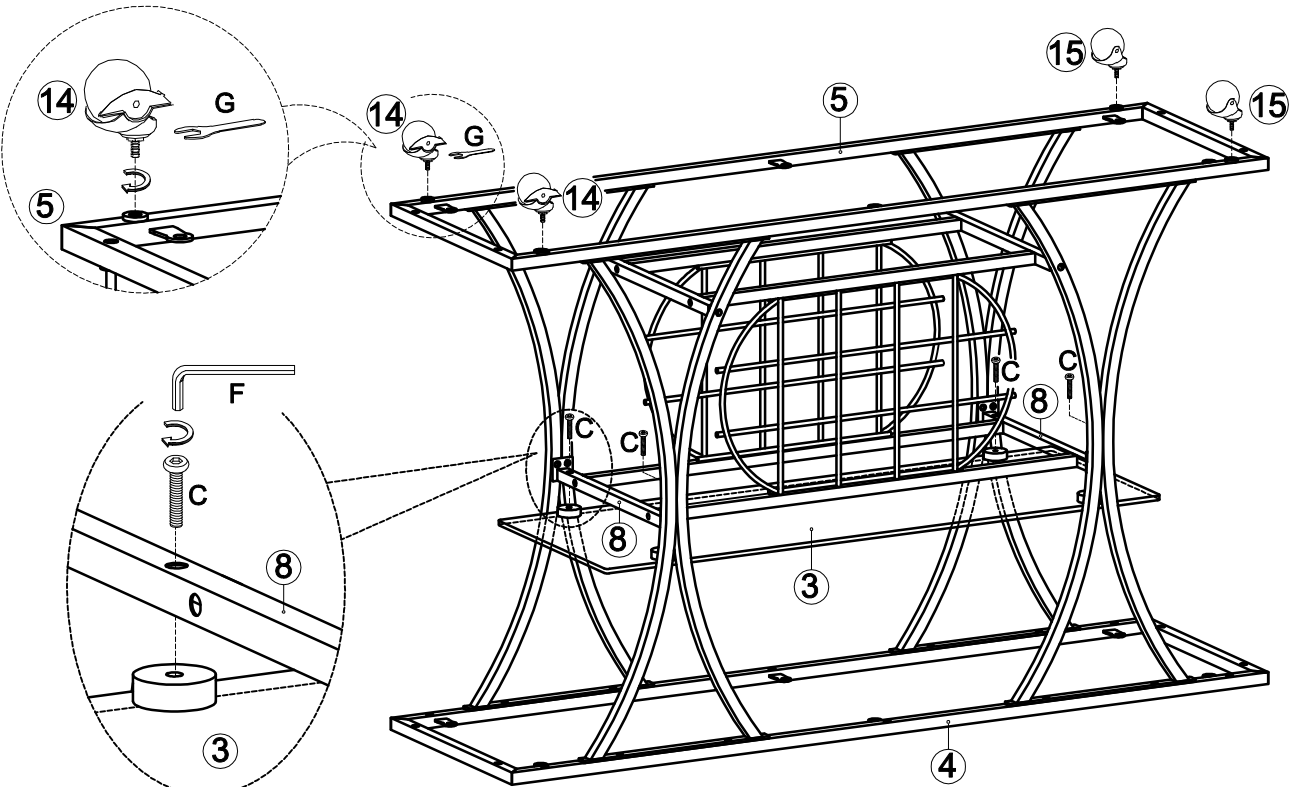

Step 7

E x 12

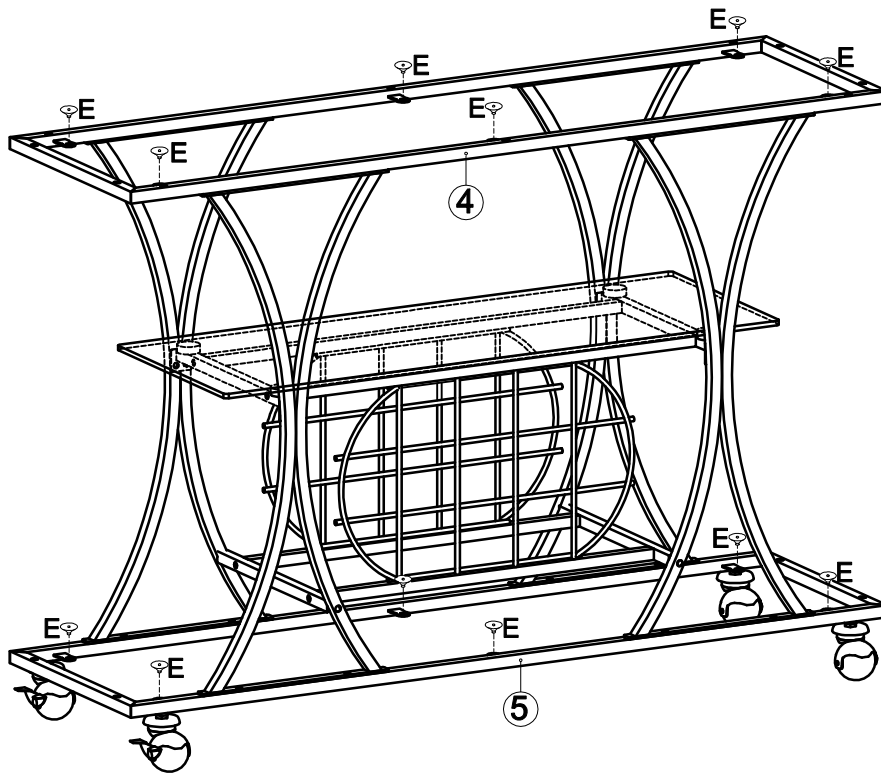

Step 8

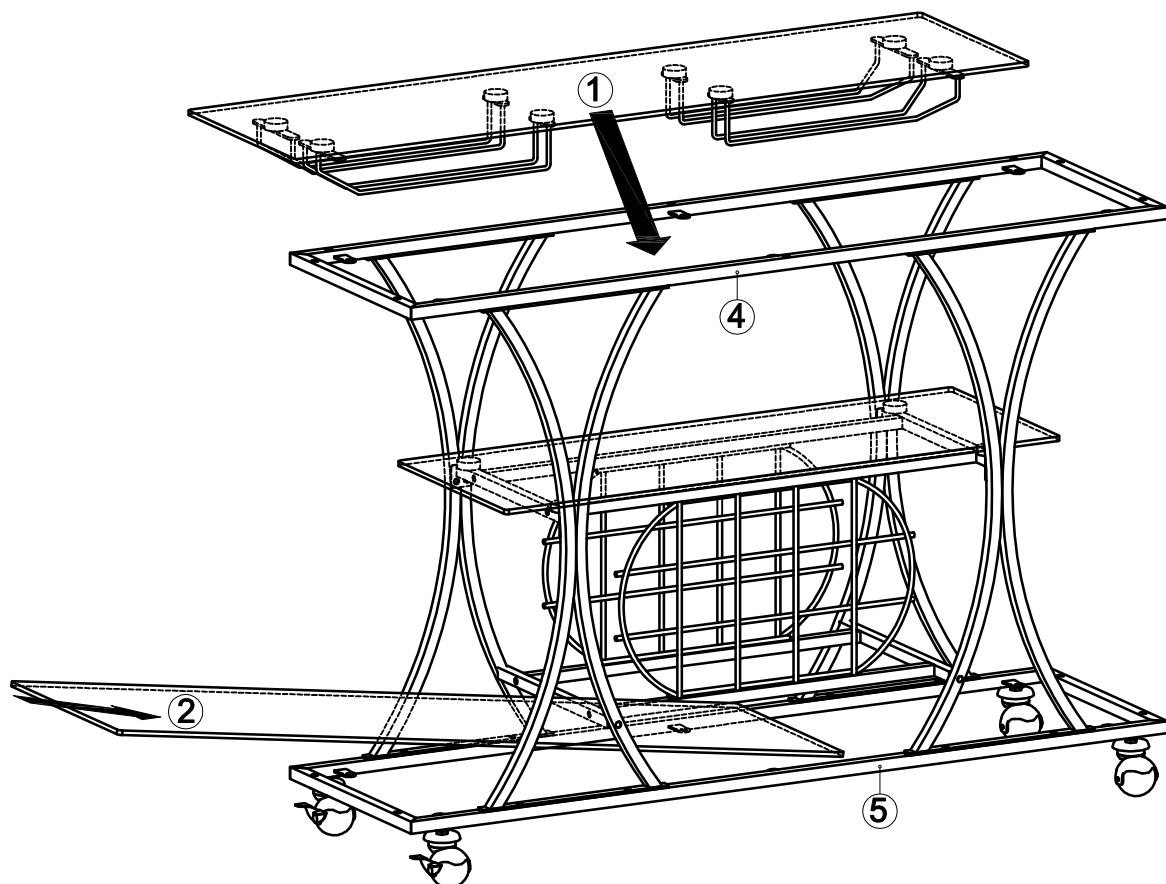

Step 9

B x 14



M6x15mm

F x 1

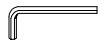

M4x55mm

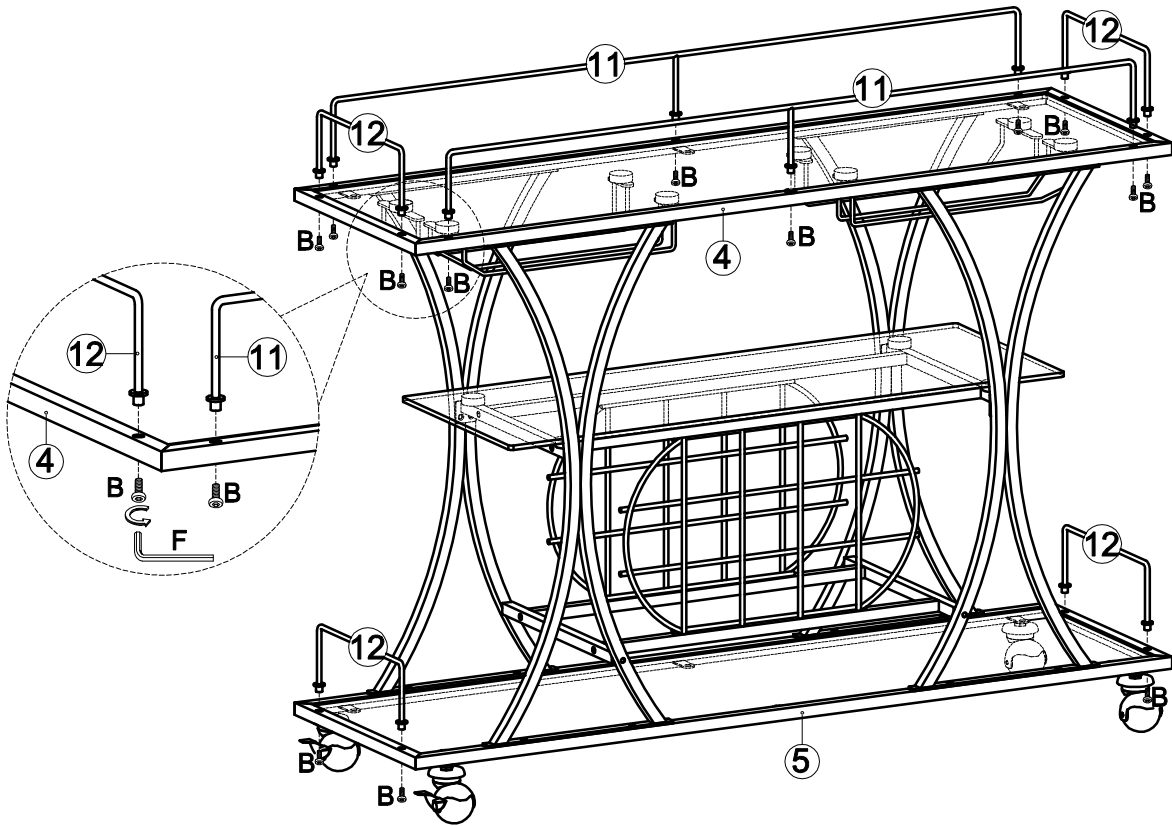

Step 10

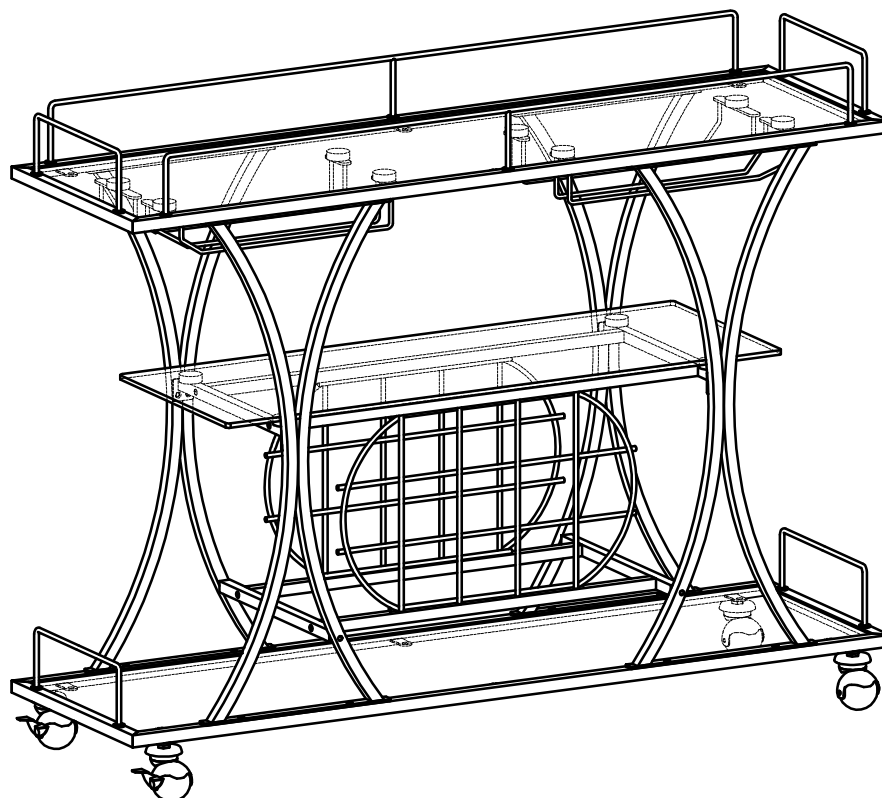

Final Assembly