

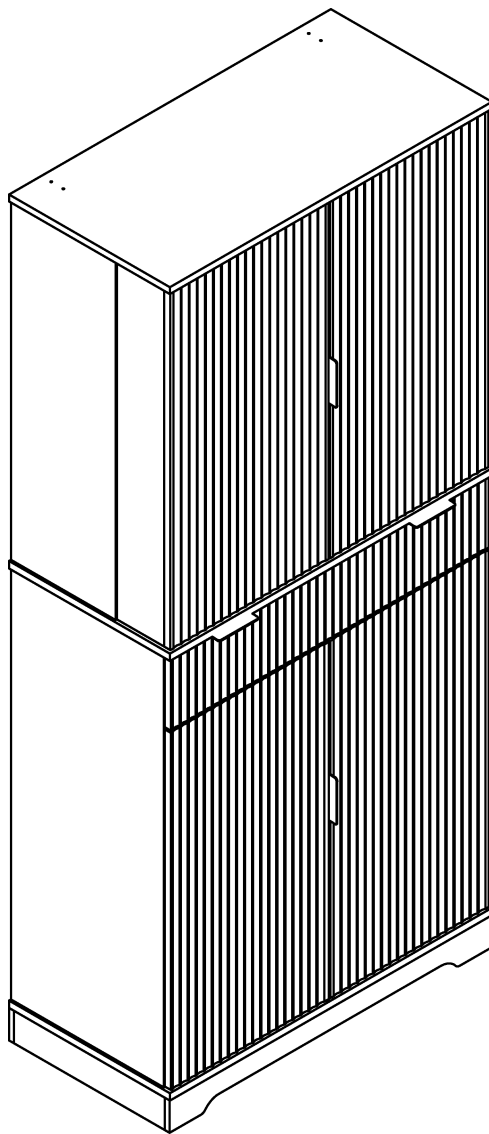

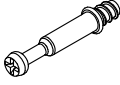







ASSEMBLY INSTRUCTIONS

INSTRUCTIONS DE MONTAGE

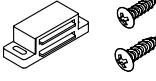
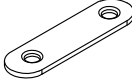
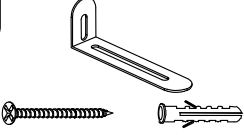
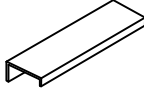
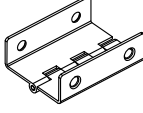
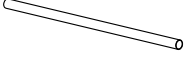

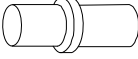
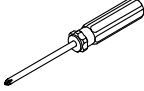
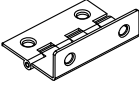
Hardware List

| | | | |
|-------------------------------------------------------------------------------------------------------------------------|-----------------------------------------------------------------------------------------------------------------------|----------------------------------------------------------------------------------------------------------------------|-----------------------------------------------------------------------------------------------------------------------|
| <p>A</p>  <p>6 x 35 mm</p> | <p>B</p>  <p>Ø15 x 10 mm</p> | <p>C</p>  <p>M4 x 40 mm</p> | <p>D</p>  <p>Ø6 x 30 mm</p> |
| <p>Cam Bolt (64 pcs)</p> | <p>Cam Nut (64 pcs)</p> | <p>Chip Board Screw (40 pcs)</p> | <p>Wood dowel (42 pcs)</p> |
| <p>E</p>  | <p>F</p>  <p>M3.5 x 12 mm</p> | <p>G</p>  <p>M3 x 14 mm</p> | <p>H</p>  |
| <p>Drawer Right (8 pcs)</p> | <p>Chip Board Screw (128 pcs)</p> | <p>Door Stopper (4 pcs)</p> | <p>Door Stopper (4 pcs)</p> |
| <p>J</p>  <p>M4 x 40 mm</p> | <p>K</p>  | <p>L</p>  | <p>M</p>  |
| <p>Anti-tip device (2 pcs)</p> | <p>Handle (6 pcs)</p> | <p>Hinge (6 pcs)</p> | <p>Wooden Rod (350mm) (6 pcs)</p> |
| <p>N</p>  <p>M3.5 x 16 mm</p> | <p>P</p>  | <p>Q</p>  | <p>R</p>  |
| <p>Single Plastic Cap (16 pcs)</p> | <p>Shelf Support steel (8 pcs)</p> | <p>Screwdriver (1 pc)</p> | <p>Hinge (4 pcs)</p> |
| <p>S</p>  | | | |
| <p>Right angle buckle (8 pcs)</p> | | | |

**ASSEMBLY TOOLS REQUIRED(NOT INCLUDED)
OUTILS DE MONTAGE NÉCESSAIRES (NON INCLUS)**





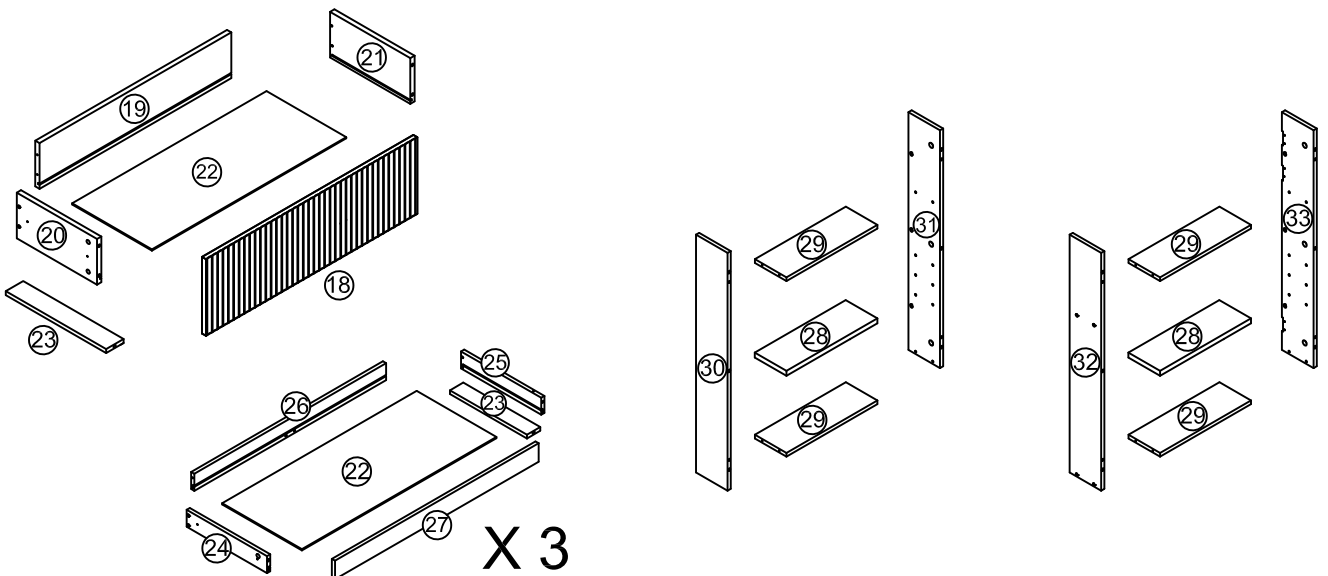
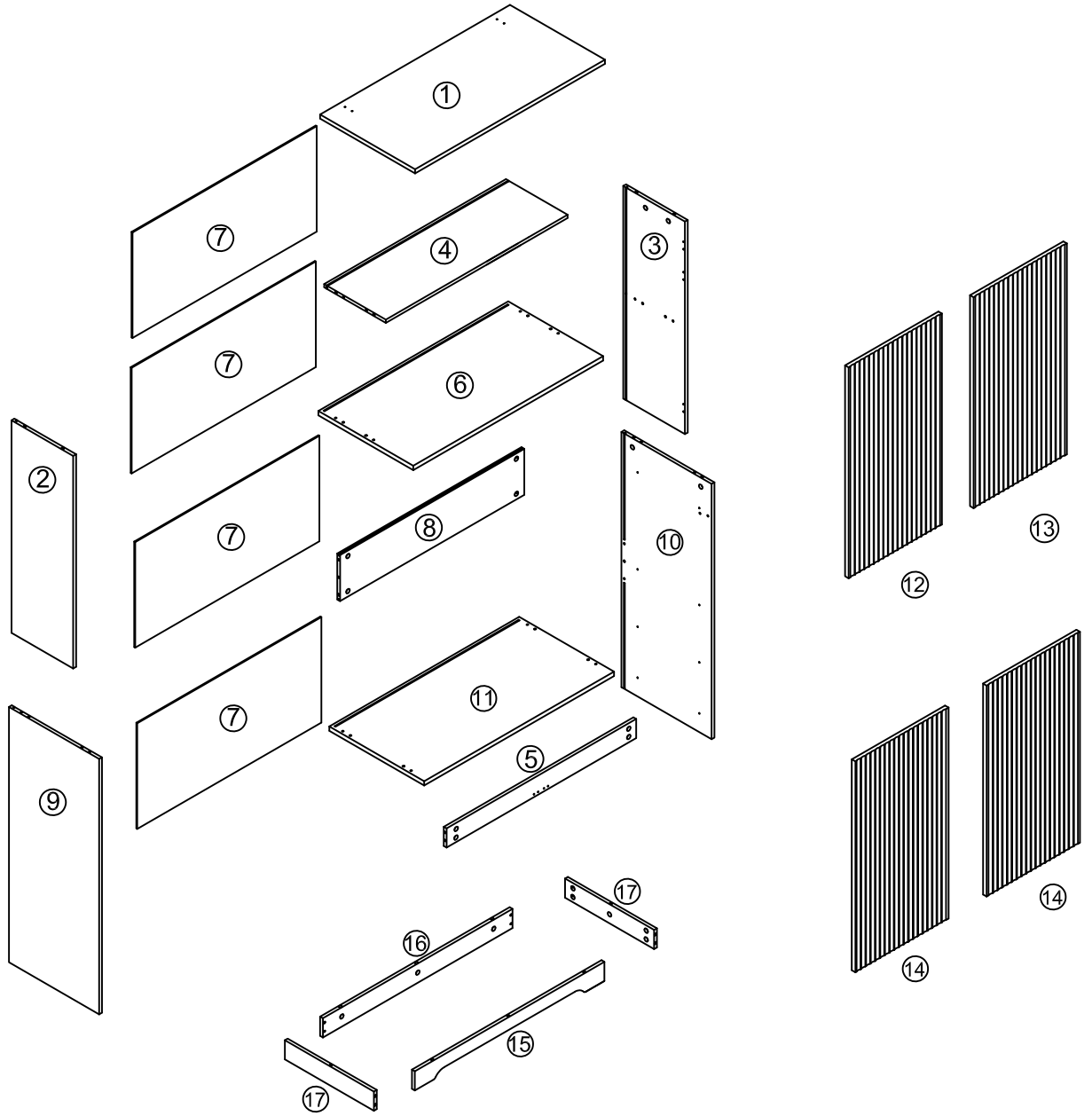

Detail View

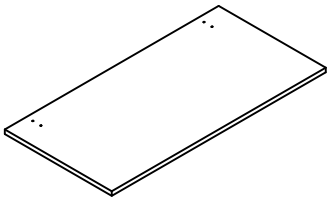
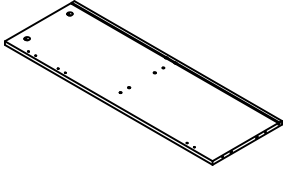
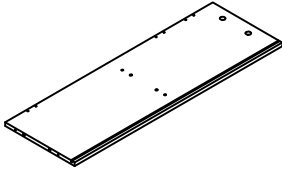
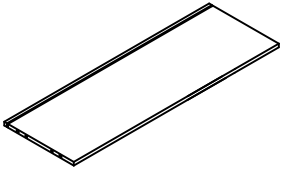
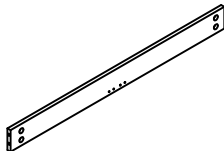
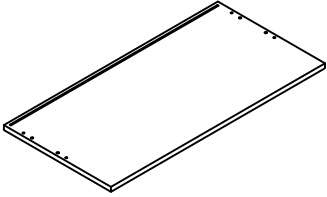
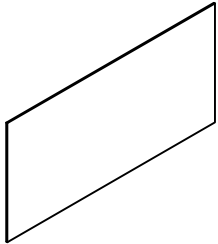
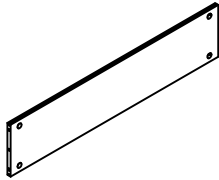
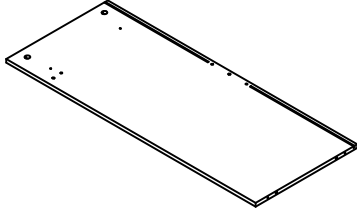
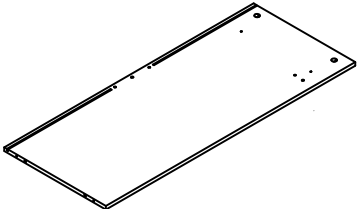
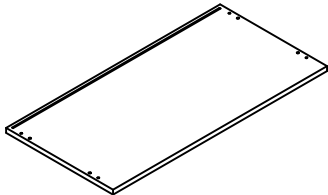
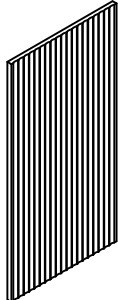
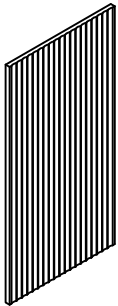
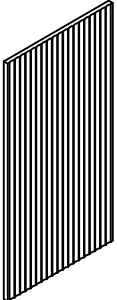
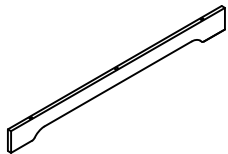

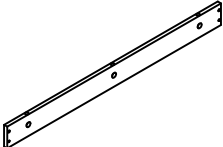
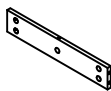
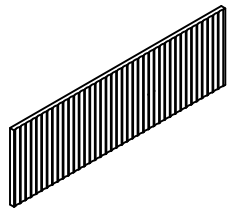
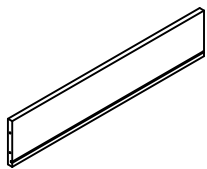
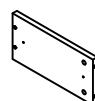
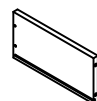
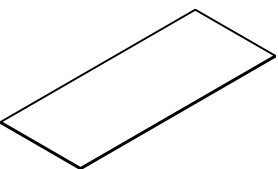
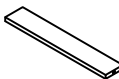

Part List

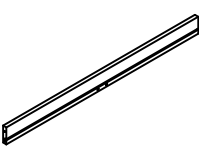
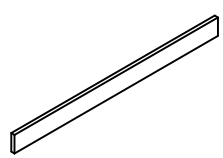
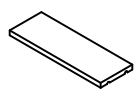
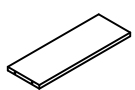
| | | |
|-------------------------------------------------------------------------------------------------------------------------------------|-----------------------------------------------------------------------------------------------------------------------------------|---------------------------------------------------------------------------------------------------------------------------------------|
| <p>① 800 x 400 x 15 mm</p>  <p>1 pc</p> | <p>② 776 x 260 x 12 mm</p> <p>L</p>  <p>1 pc</p> | <p>③ 776 x 260 x 12 mm</p>  <p>R</p> <p>1 pc</p> |
| <p>④ 766 x 259 x 12 mm</p>  <p>1 pc</p> | <p>⑤ 766 x 60 x 15 mm</p>  <p>1 pc</p> | <p>⑥ 800 x 400 x 15 mm</p>  <p>1 pc</p> |
| <p>⑦ 776 x 392 x 3 mm</p>  <p>4 pcs</p> | <p>⑧ 766 x 168 x 12 mm</p>  <p>1 pc</p> | <p>⑨ 932 x 380 x 12 mm</p>  <p>1 pc</p> |
| <p>⑩ 932 x 380 x 12 mm</p>  <p>1 pc</p> | <p>⑪ 800 x 400 x 12 mm</p>  <p>1 pc</p> | <p>⑫ 770 x 394 x 15 mm</p> <p>L</p>  <p>1 pc</p> |
| <p>⑬ 770 x 394 x 15 mm</p> <p>R</p>  <p>1 pc</p> | <p>⑭ 770 x 394 x 15 mm</p>  <p>2 pcs</p> | <p>⑮ 799 x 70 x 12 mm</p>  <p>1 pc</p> |

Part List

| | | |
|---------------------------------------------------------------------------------------------------------------------------------------------|------------------------------------------------------------------------------------------------------------------------------------------|-----------------------------------------------------------------------------------------------------------------------------------------------|
| <p>①⑥ 799 x 70 x 12 mm</p>  <p>1 pc</p> | <p>①⑦ 375 x 70 x 12 mm</p>  <p>2 pcs</p> | <p>①⑧ 791 x 151 x 15 mm</p>  <p>1 pc</p> |
| <p>①⑨ 717 x 98 x 12 mm</p>  <p>1 pc</p> | <p>②⑩ 300 x 98 x 12 mm</p> <p>L</p>  <p>1 pc</p> | <p>②⑪ 300 x 98 x 12 mm</p>  <p>R</p> <p>1 pc</p> |
| <p>②② 727 x 298 x 3 mm</p>  <p>4 pcs</p> | <p>②③ 288 x 50 x 12 mm</p>  <p>4 pcs</p> | <p>②④ 300 x 55 x 12 mm</p> <p>L</p>  <p>3 pcs</p> |
| <p>②⑤ 300 x 55 x 12 mm</p>  <p>R</p> <p>3 pcs</p> | <p>②⑥ 717 x 55 x 12 mm</p>  <p>3 pcs</p> | <p>②⑦ 761 x 60 x 12 mm</p>  <p>3 pcs</p> |
| <p>②⑧ 340 x 117 x 12 mm</p>  <p>2 pcs</p> | <p>②⑨ 340 x 117 x 12 mm</p>  <p>4 pcs</p> | <p>③⑩ 770 x 117 x 12 mm</p>  <p>1 pc</p> |

Part List

| | | |
|----------------------------------------------------------------------------------------------------------------------------------|----------------------------------------------------------------------------------------------------------------------------------|------------------------------------------------------------------------------------------------------------------------------------|
| <p>③①</p> <p>770 x 117 x 12 mm</p>  <p>1 pc</p> | <p>③②</p> <p>770 x 117 x 12 mm</p>  <p>1 pc</p> | <p>③③</p> <p>770 x 117 x 12 mm</p>  <p>1 pc</p> |
| | | |
| | | |
| | | |
| | | |
| | | |

STEP 1

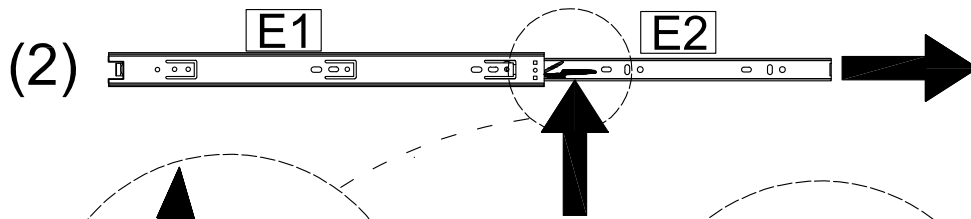
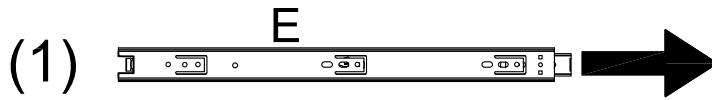
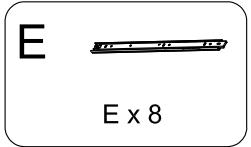

x 8

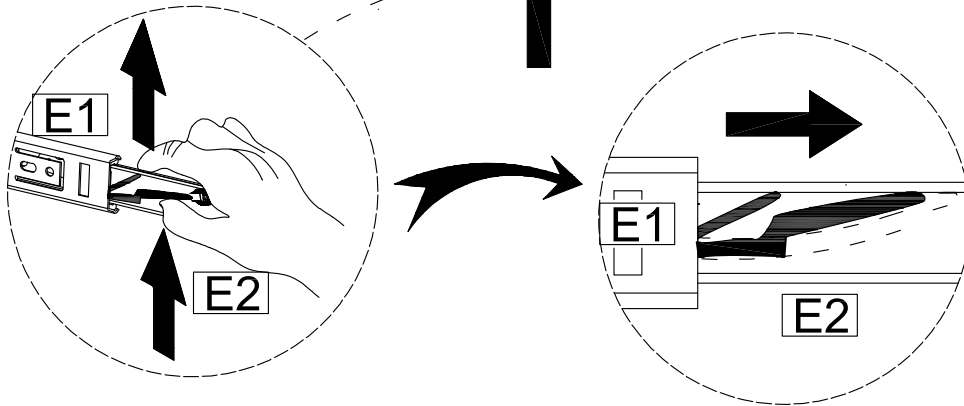

Move the black paddle upward and pull out (E2) to the right.
Déplacez la palette noire vers le haut et tirez (E2) vers la droite.

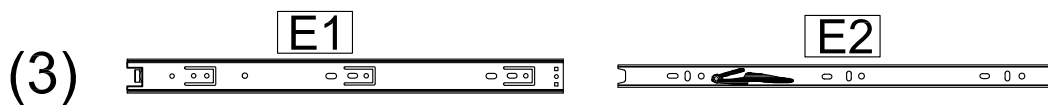

x 8

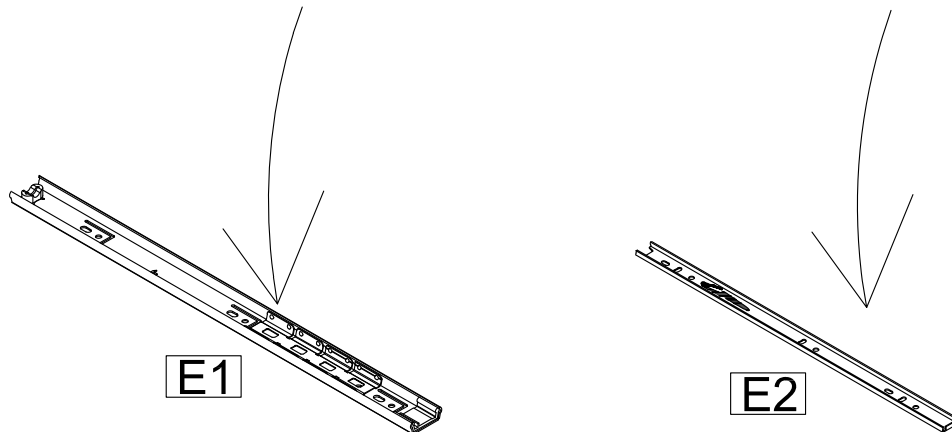

STEP 2

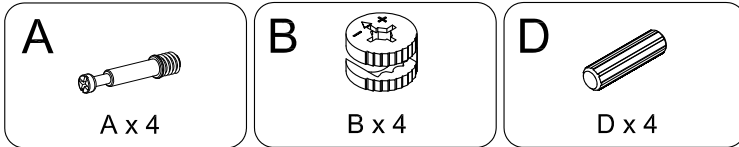
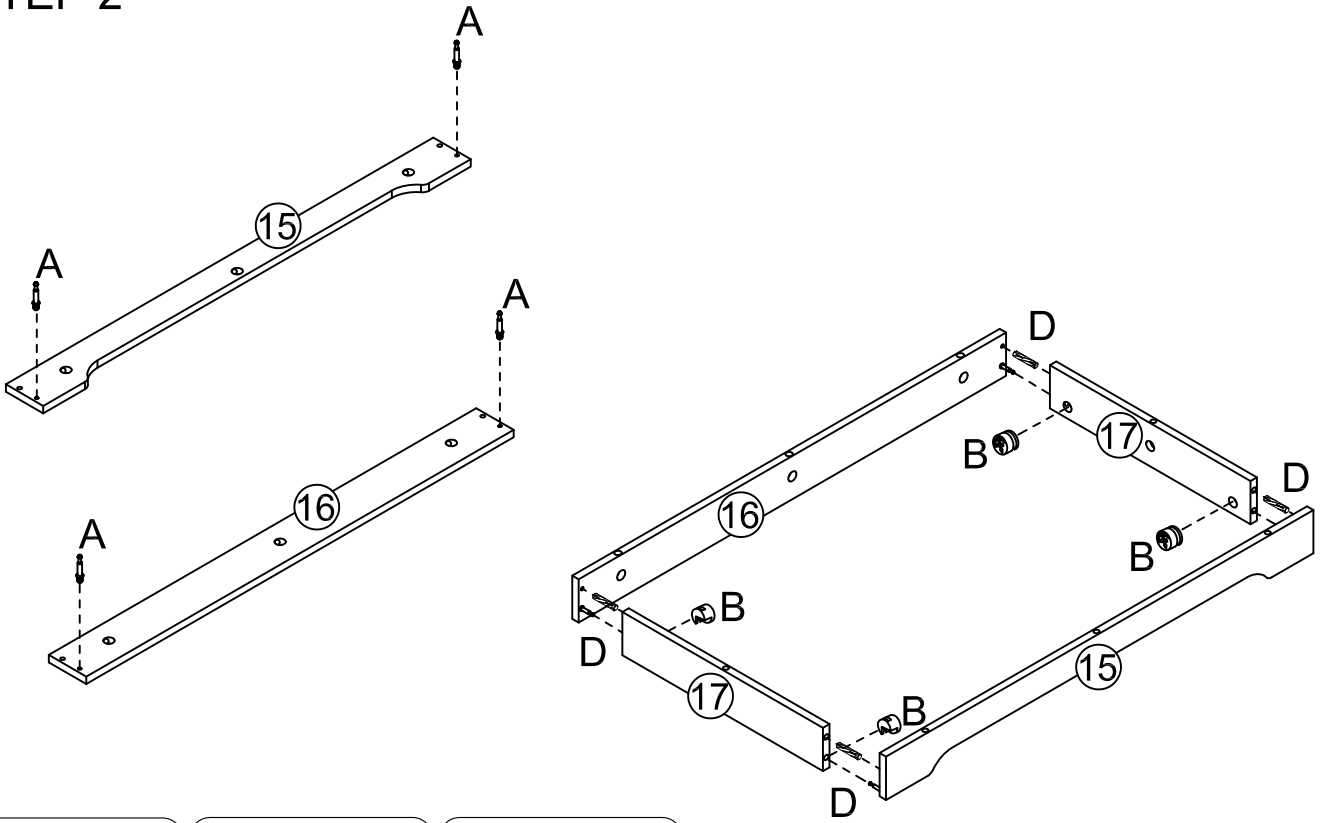

STEP 3

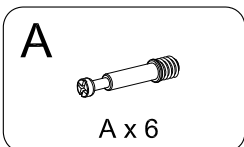
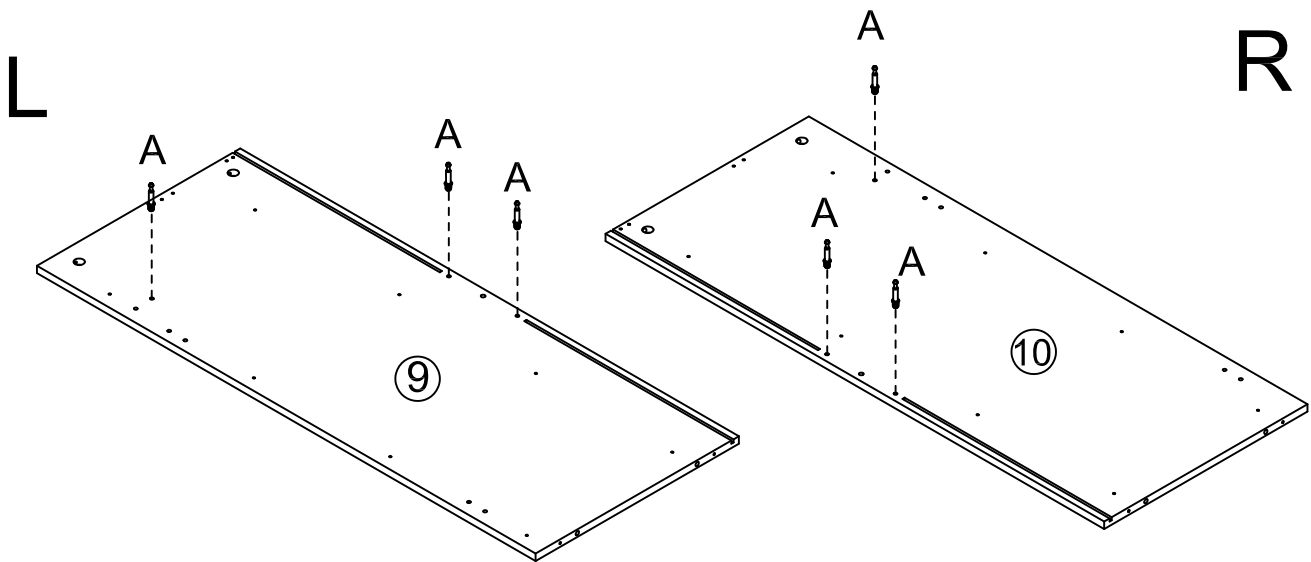

STEP 4

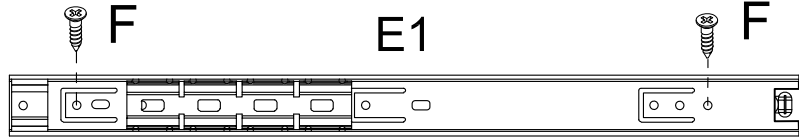

L

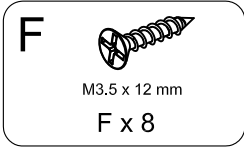
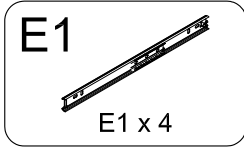
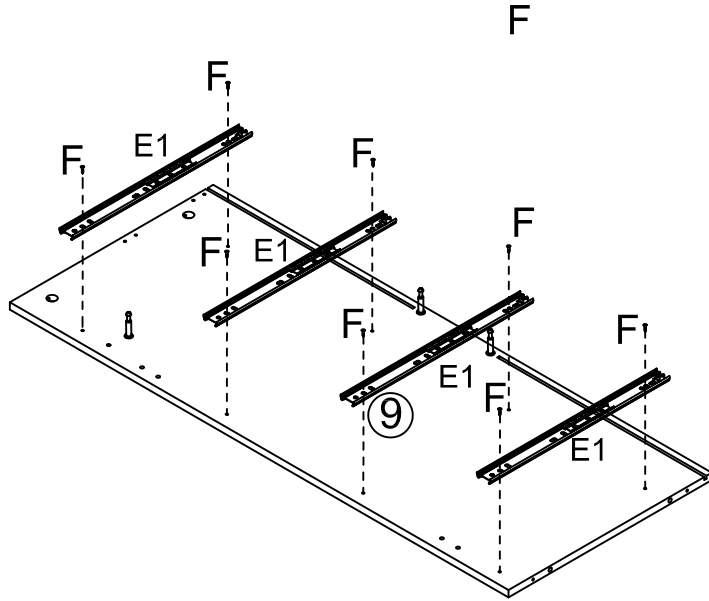

STEP 5

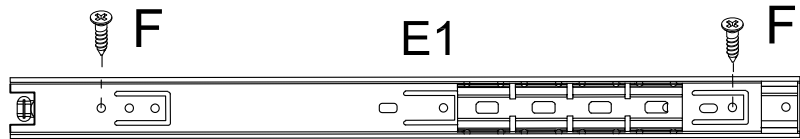

R

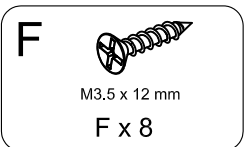
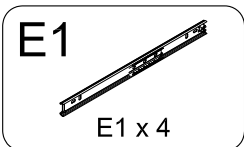
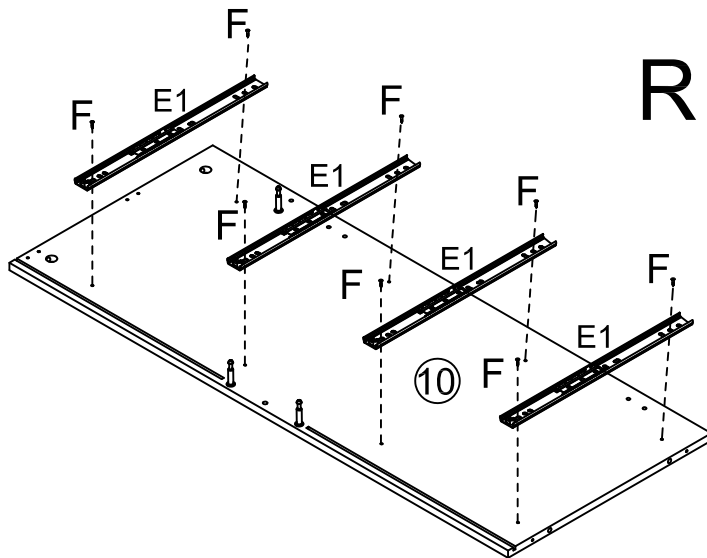



STEP 6

L

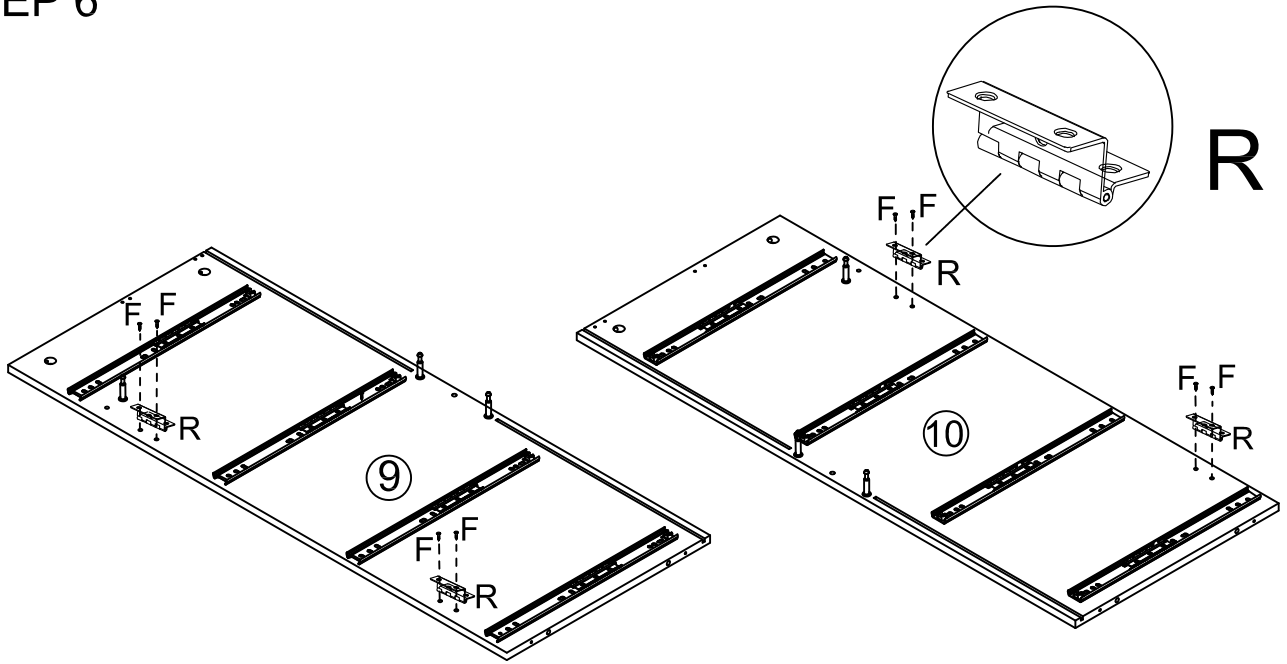
R

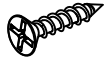

F 
M3.5 x 12 mm
F x 8

R 
R x 4

STEP 7

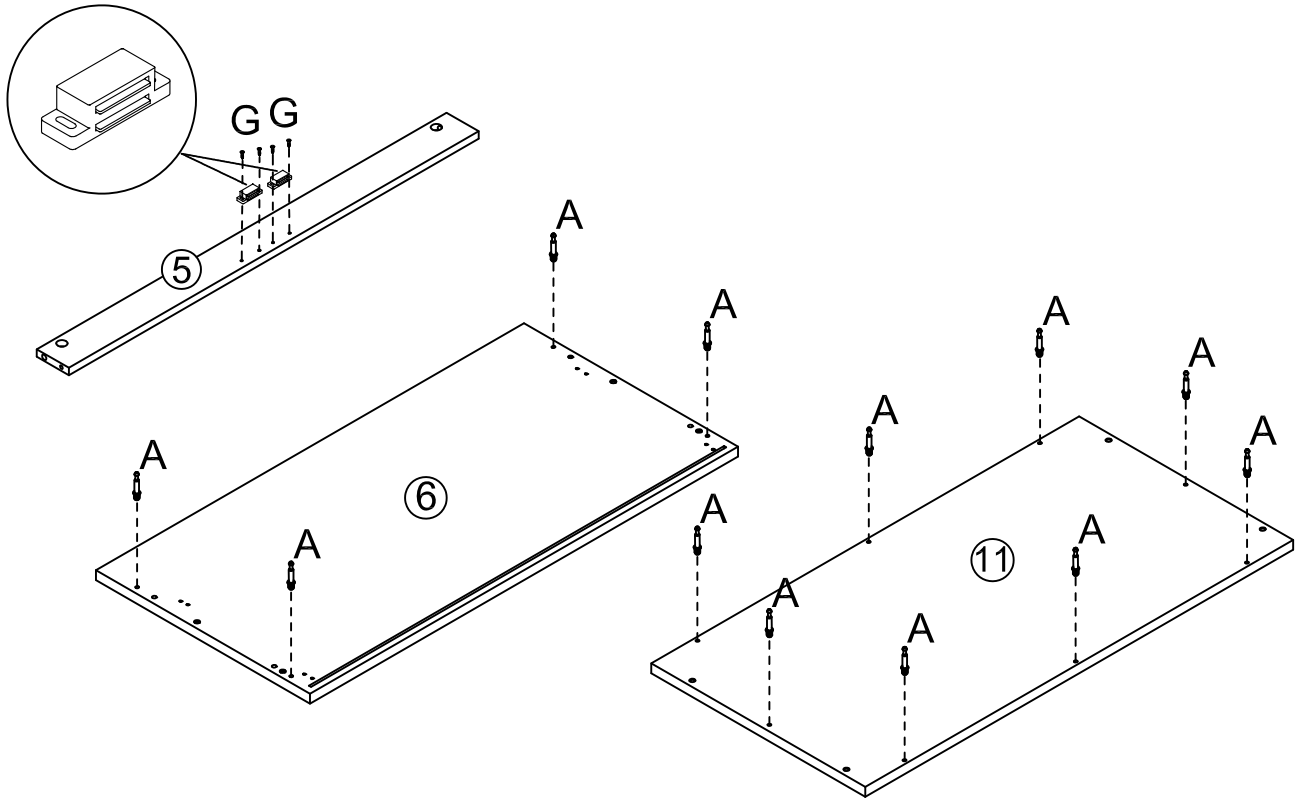

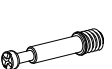
A 
A x 12

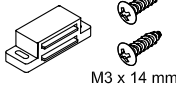
G 
G x 2
M3 x 14 mm

STEP 8

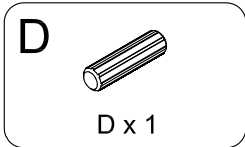
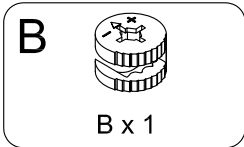
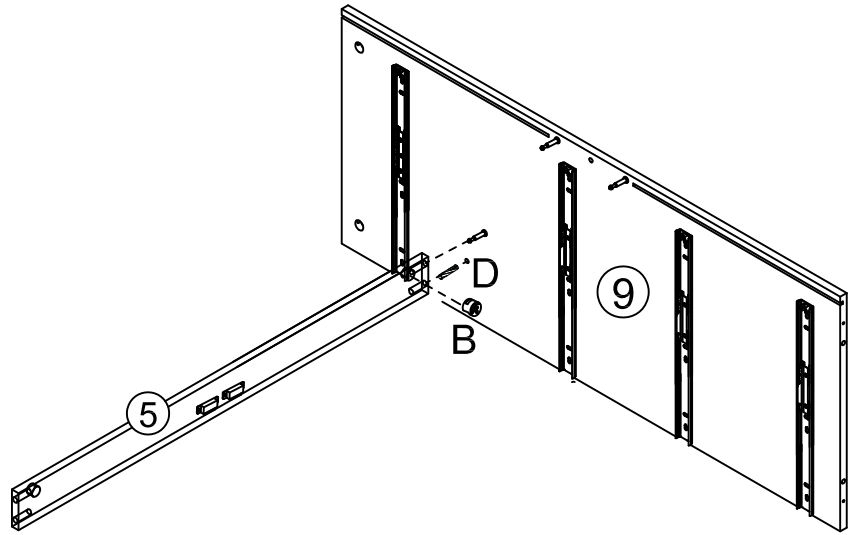

STEP 9

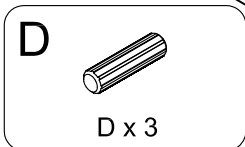
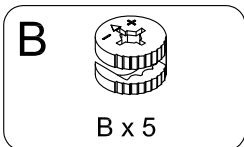
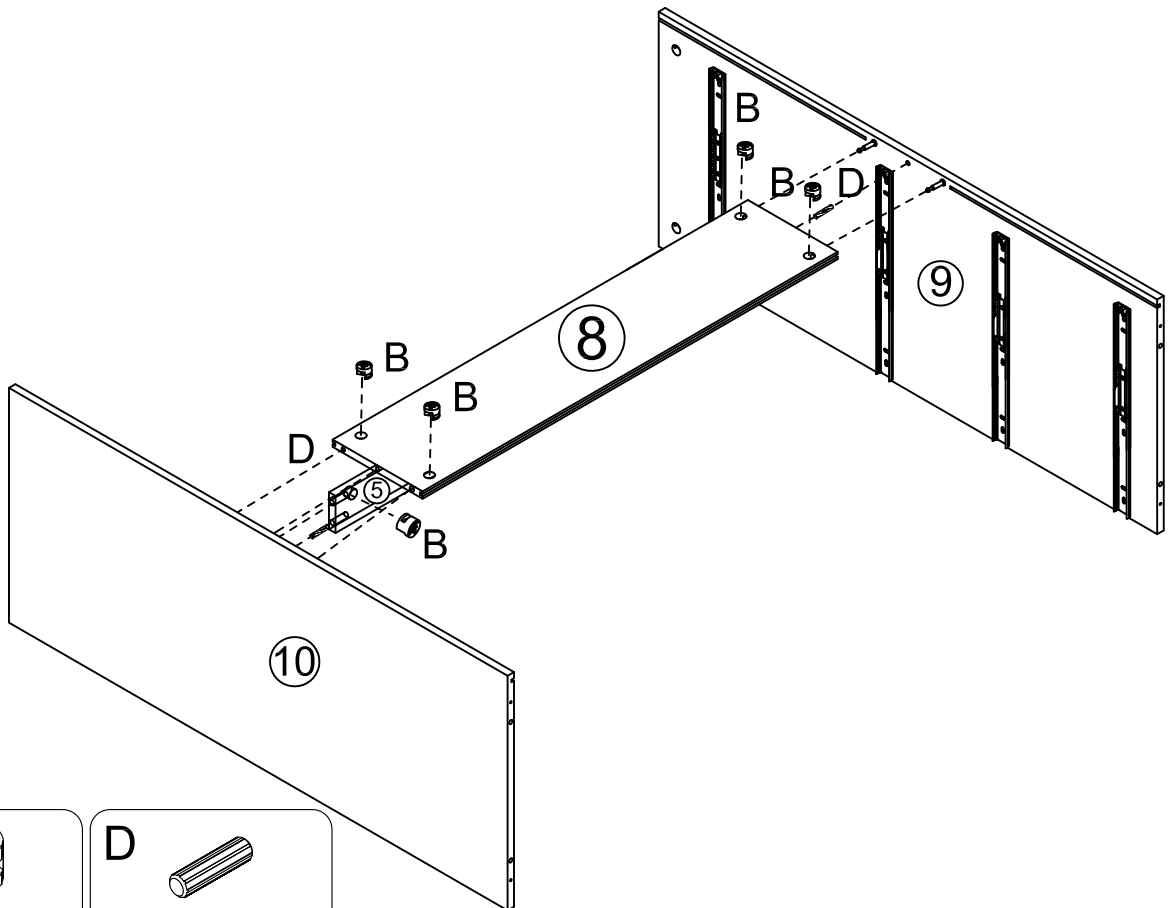

STEP 10

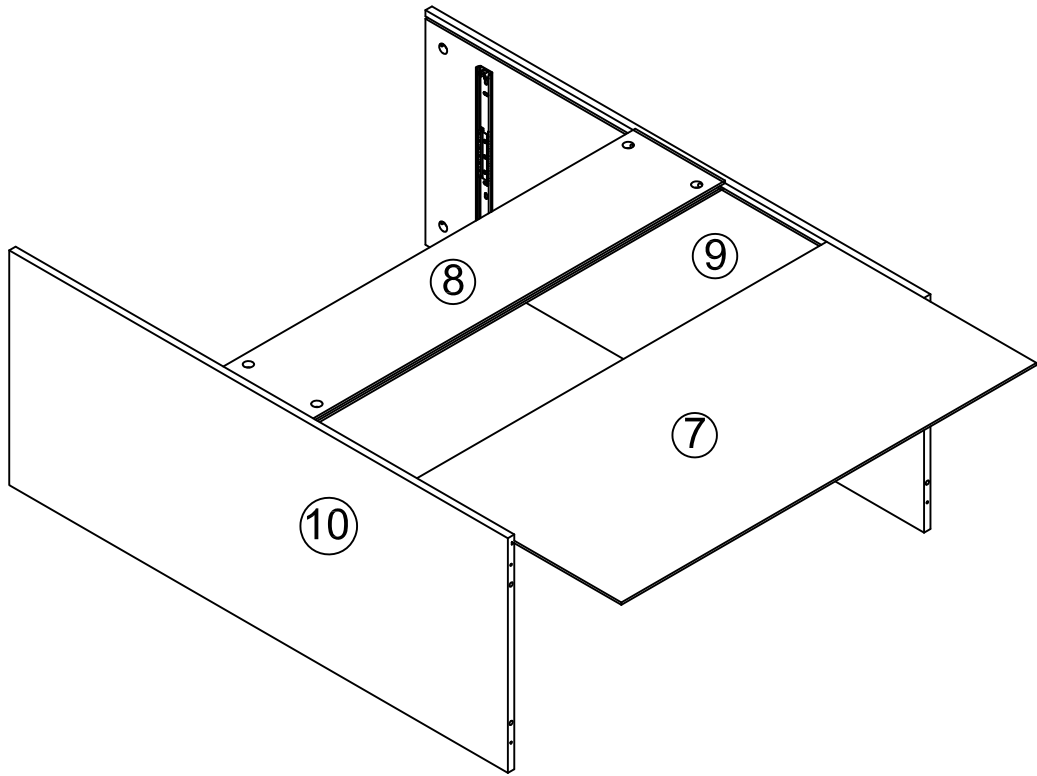

STEP 11

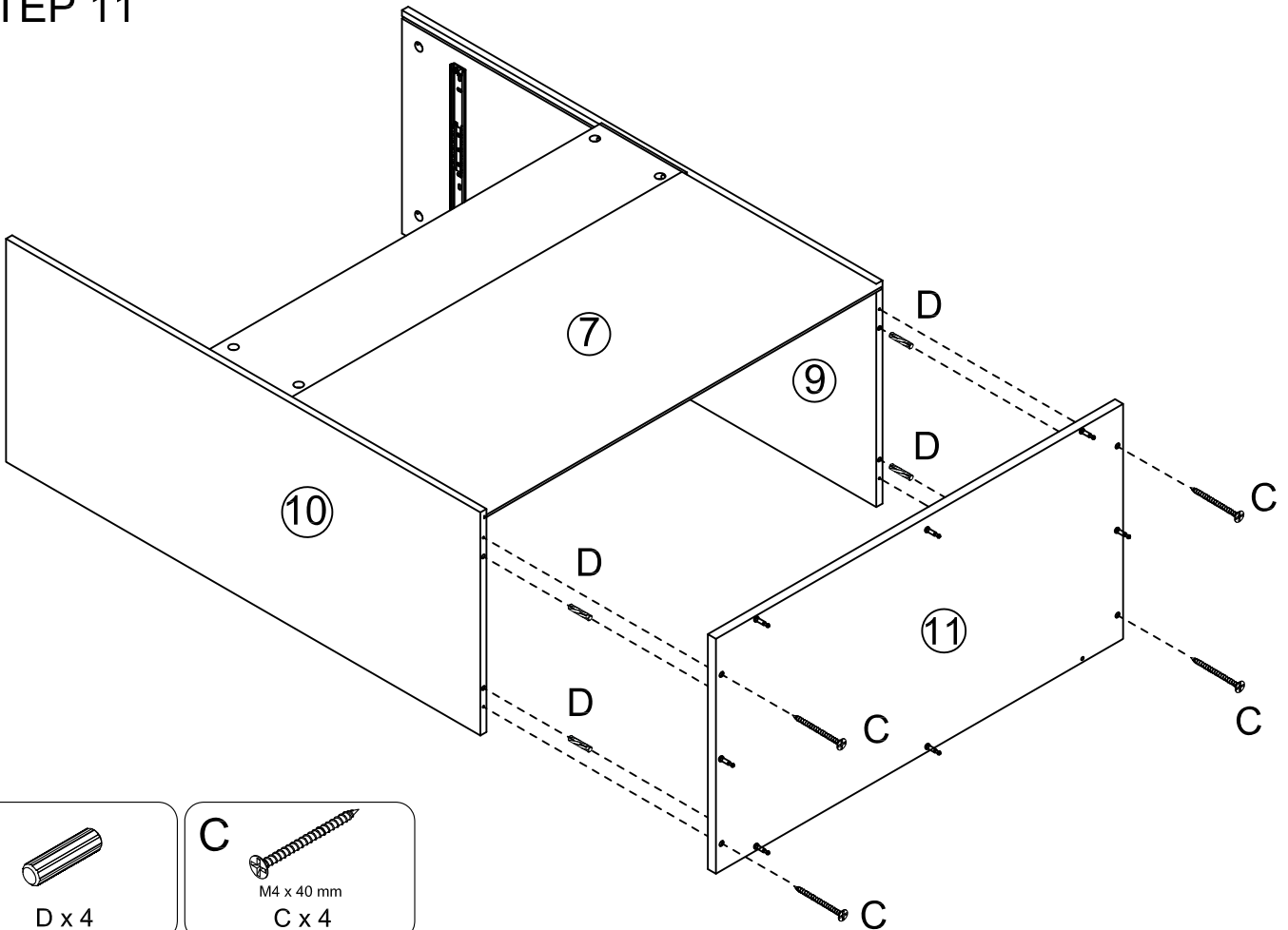

STEP 12

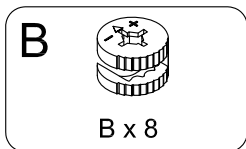
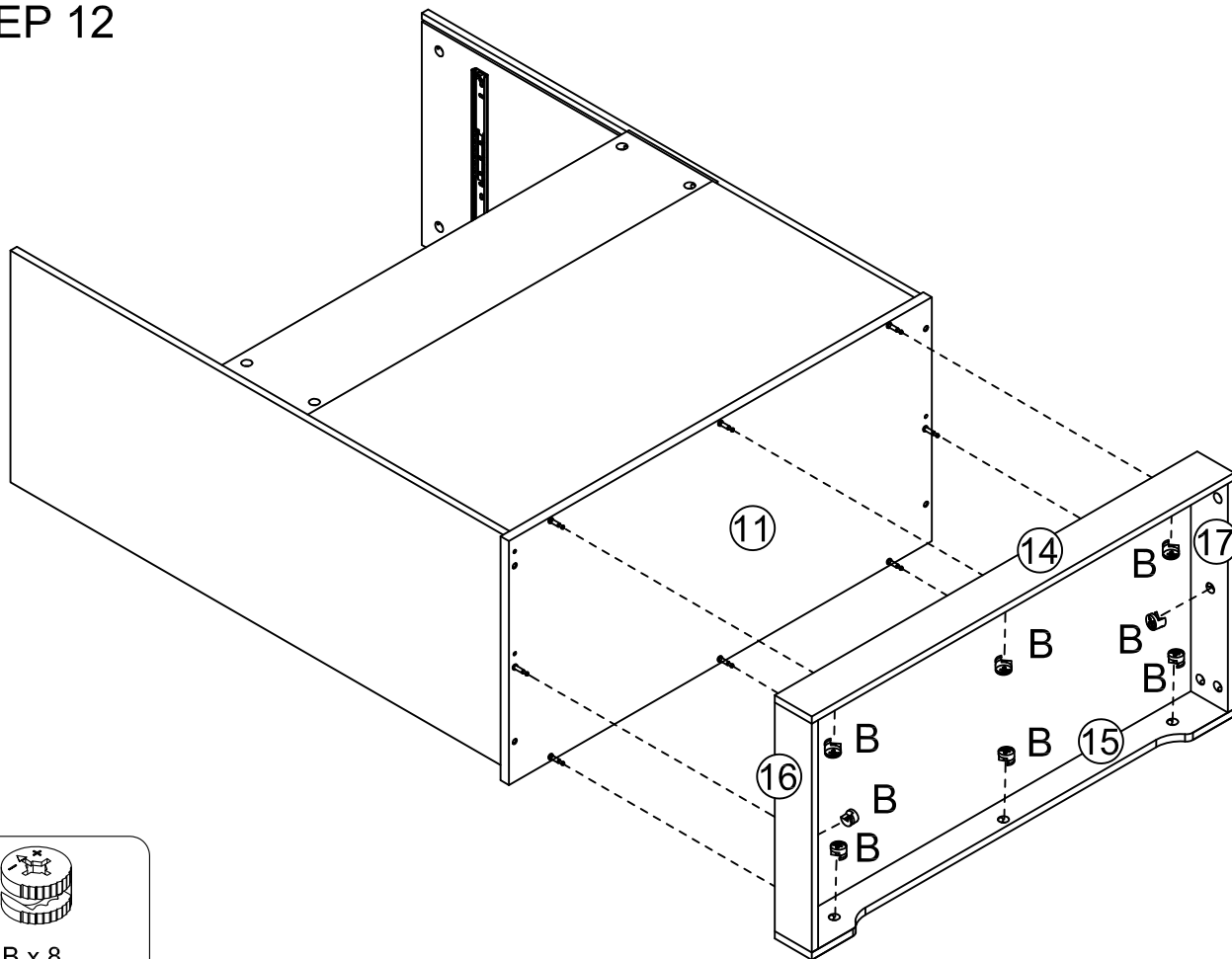

STEP 13

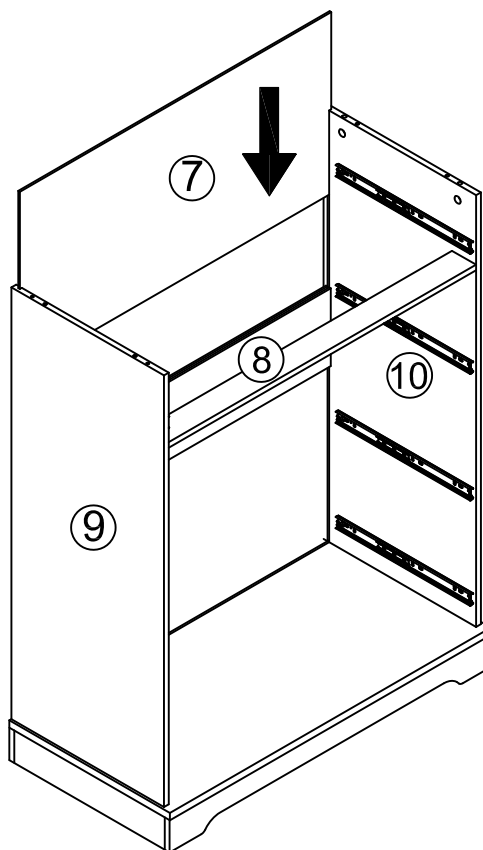

STEP 14

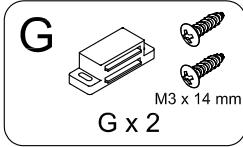
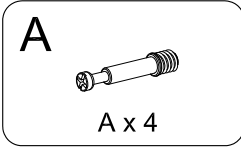
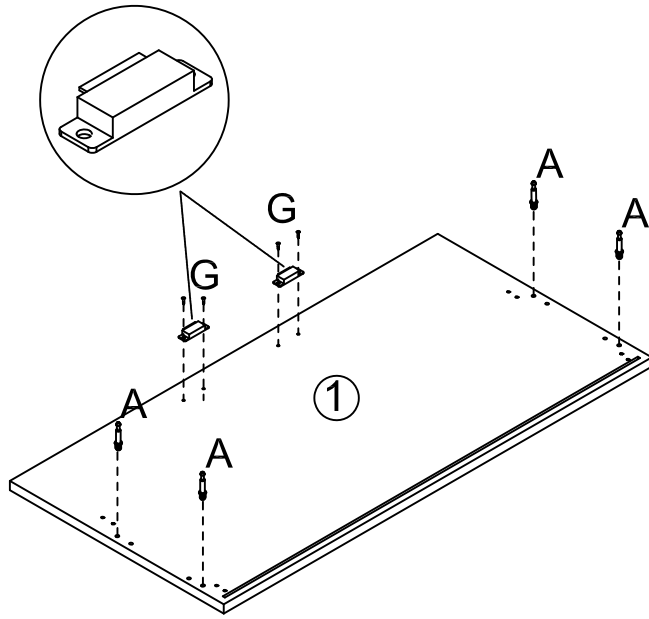

STEP 15

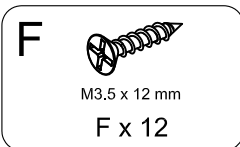
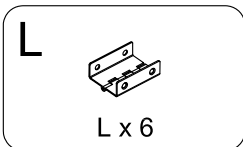
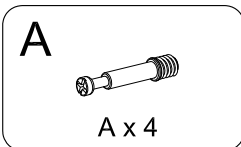
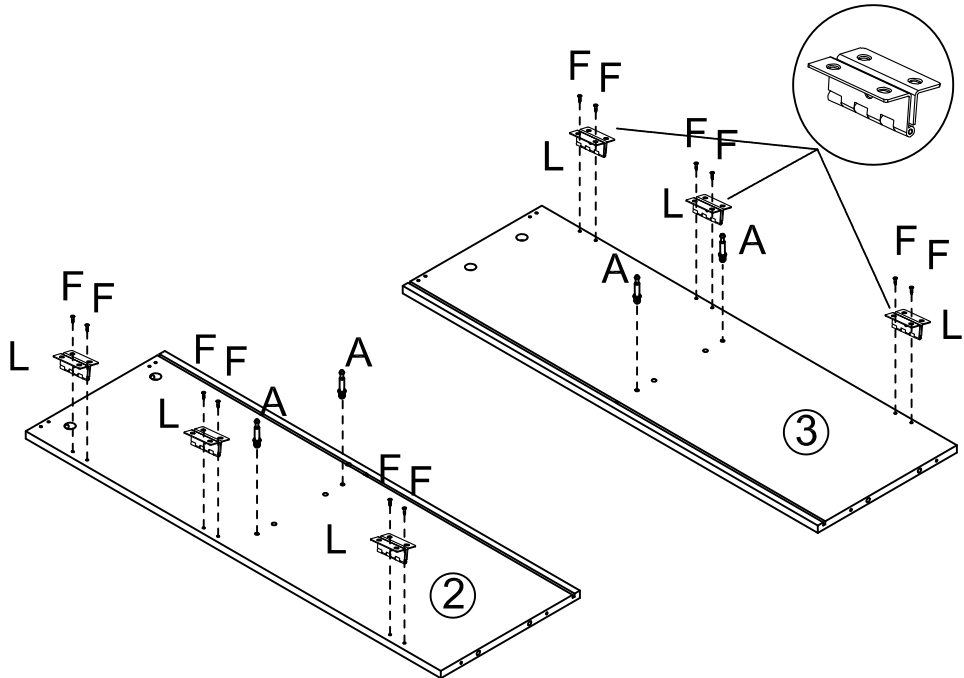

STEP 16

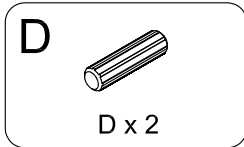
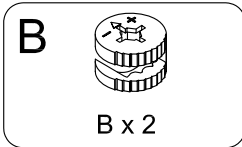
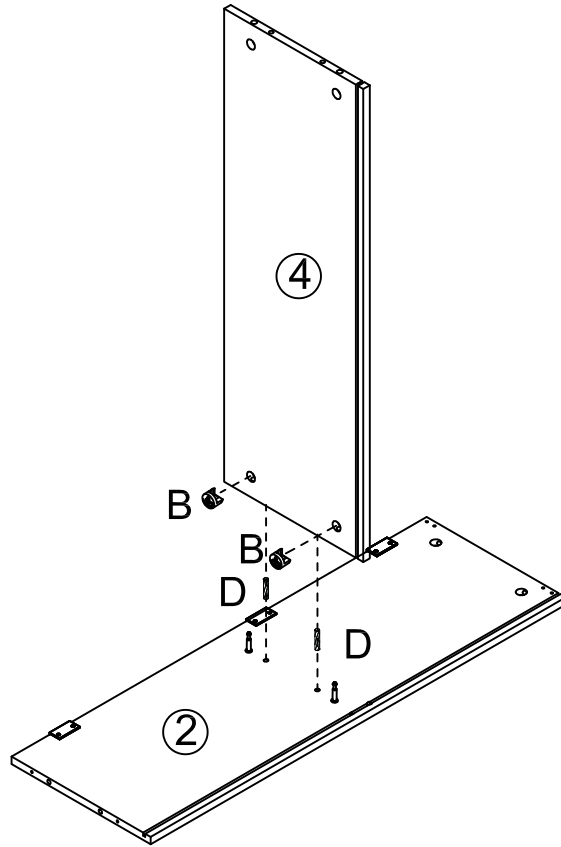

STEP 17

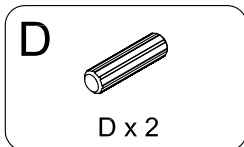
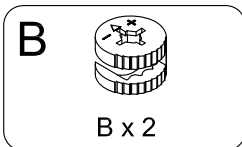
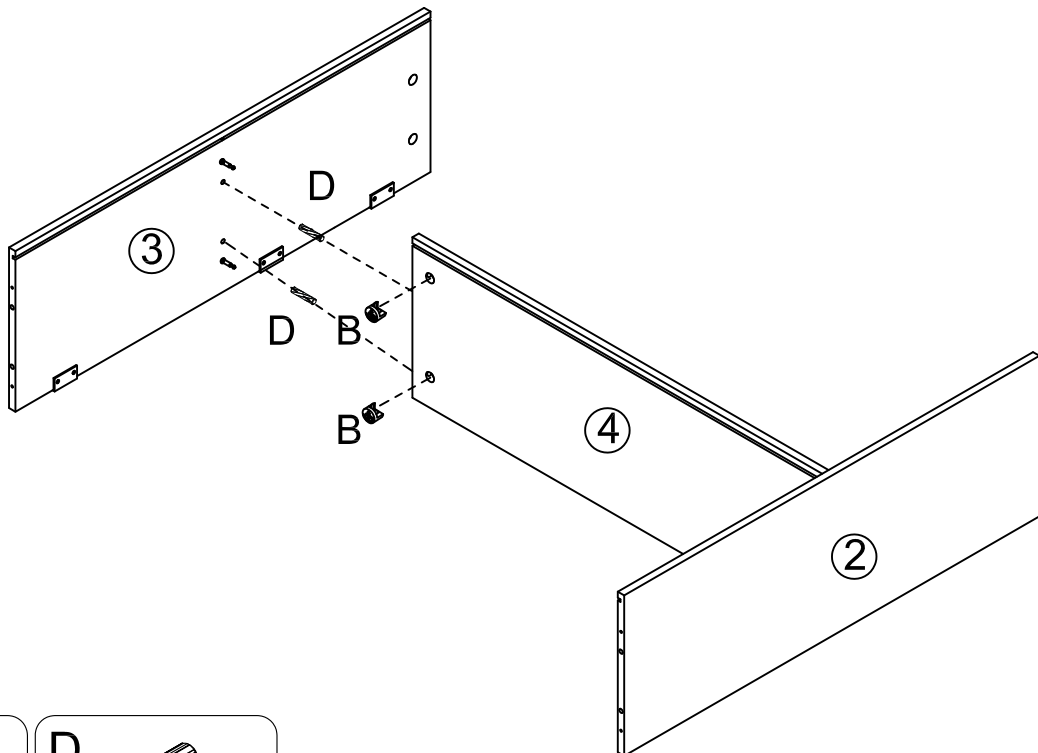

STEP 18

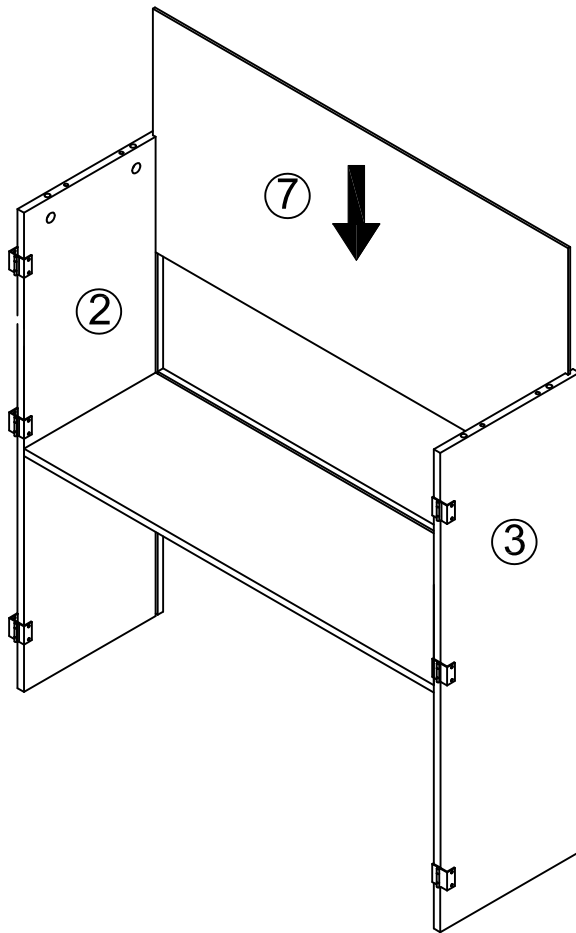

STEP 19

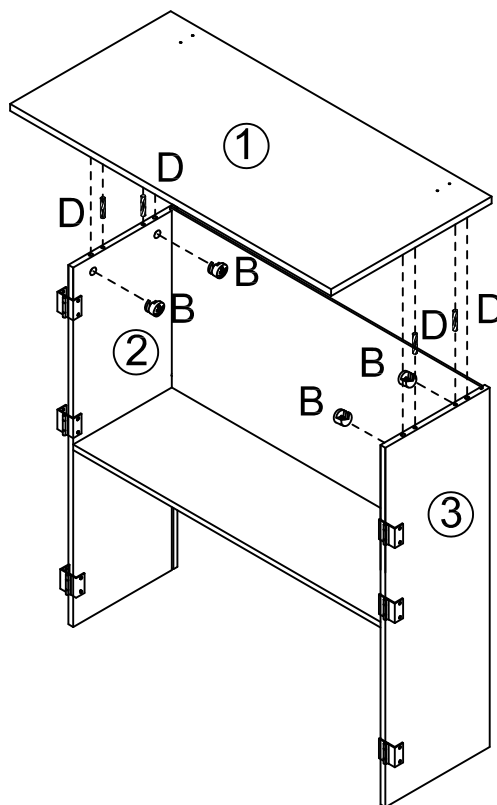

Please complete step 19 and rotate 180 °

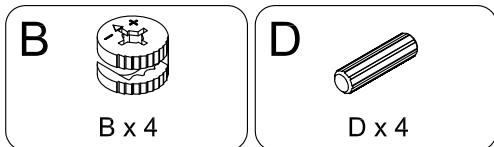

STEP 20

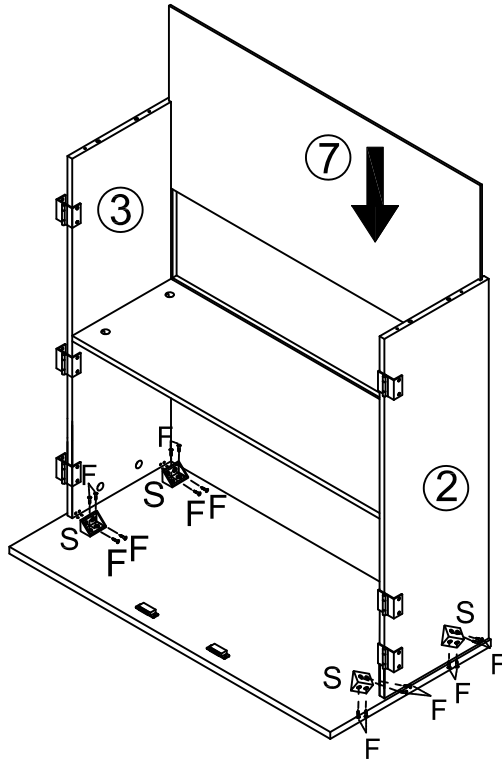



S

S x 4

F

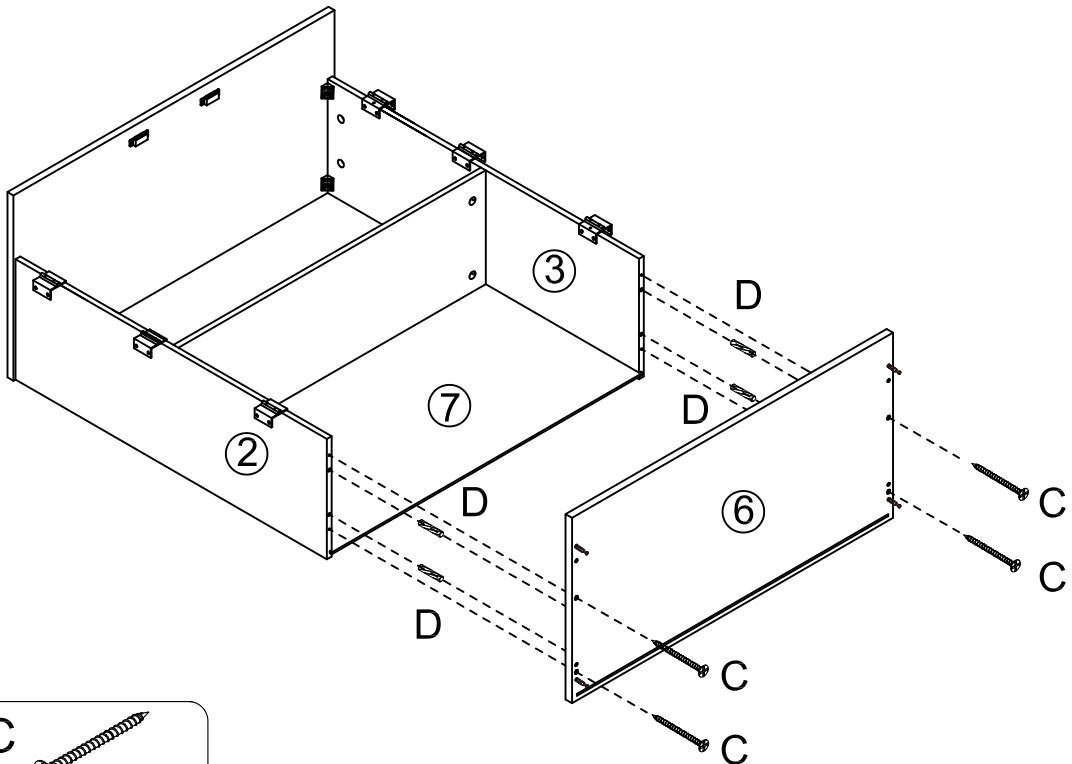
M3.5 x 12 mm
F x 16

STEP 21





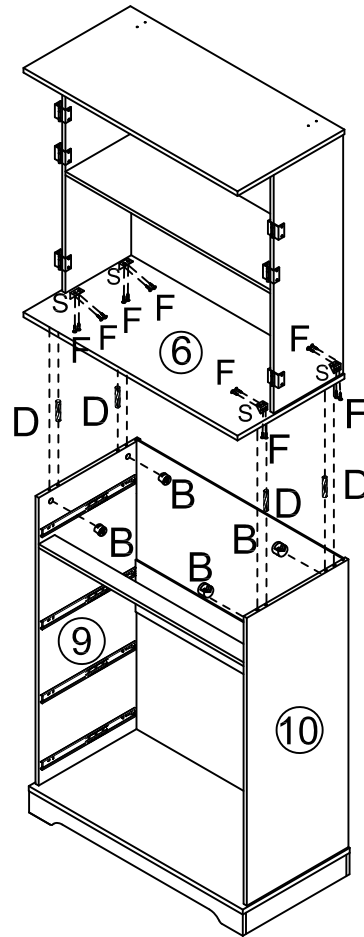

D

D x 4

C

M4 x 40 mm
C x 4



STEP 22

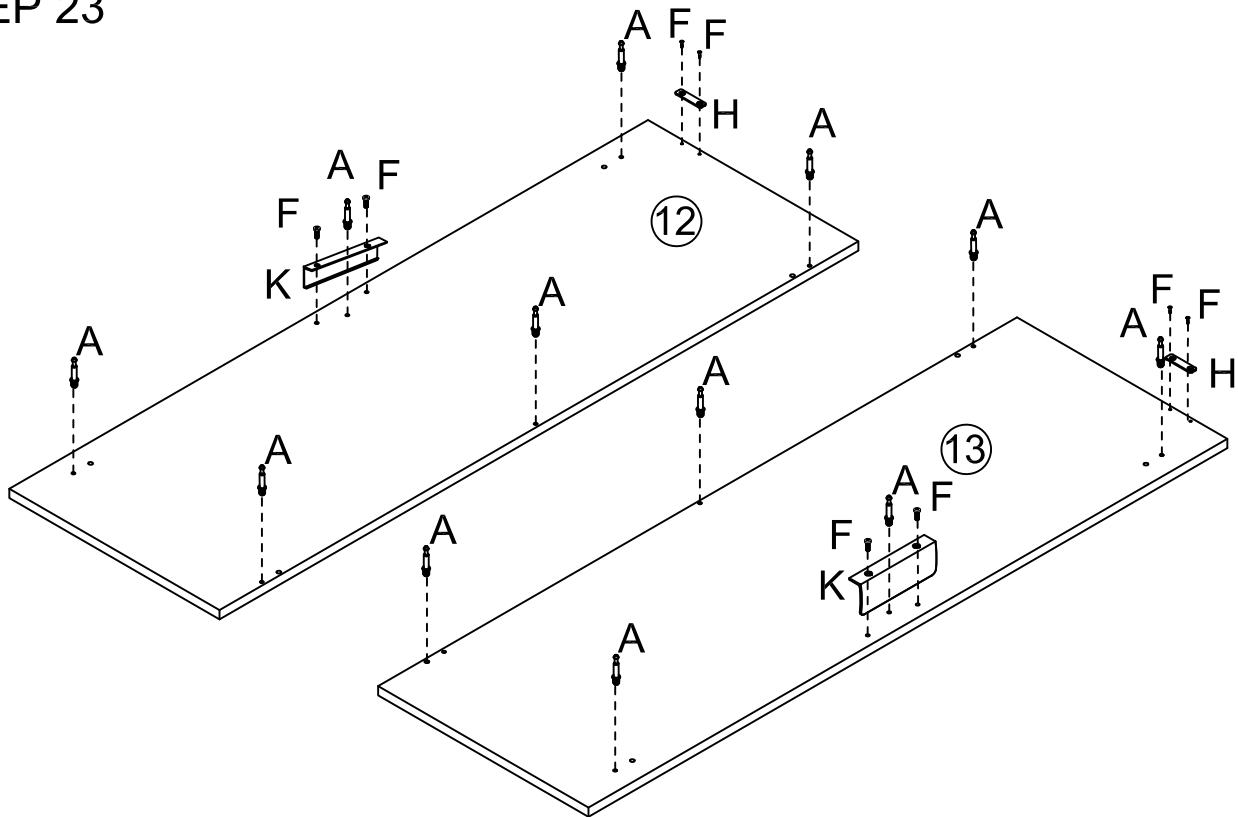

| | |
|-----------------------------------------------------------------------------------------------------------------|-----------------------------------------------------------------------------------------------------------------------------------|
| <p>B</p>  <p>B x 4</p> | <p>D</p>  <p>D x 4</p> |
| <p>S</p>  <p>S x 4</p> | <p>F</p>  <p>M3.5 x 12 mm F x 16</p> |

STEP 23

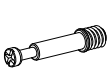
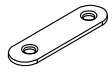

| | | | |
|-------------------------------------------------------------------------------------------------------------------|------------------------------------------------------------------------------------------------------------------|------------------------------------------------------------------------------------------------------------------|------------------------------------------------------------------------------------------------------------------------------------|
| <p>A</p>  <p>A x 12</p> | <p>H</p>  <p>H x 2</p> | <p>K</p>  <p>K x 2</p> | <p>F</p>  <p>M3.5 x 12 mm F x 8</p> |
|-------------------------------------------------------------------------------------------------------------------|------------------------------------------------------------------------------------------------------------------|------------------------------------------------------------------------------------------------------------------|------------------------------------------------------------------------------------------------------------------------------------|

STEP 24

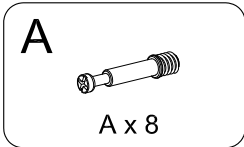
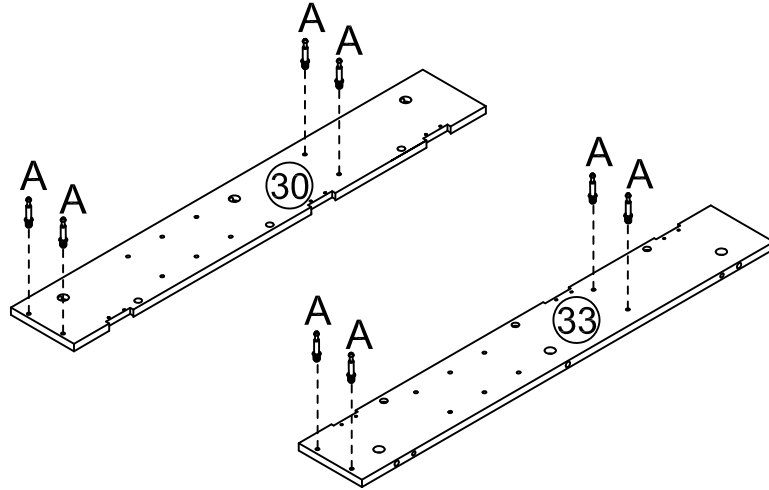

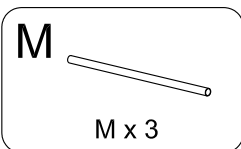
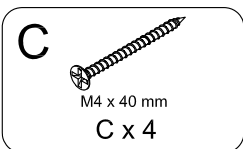
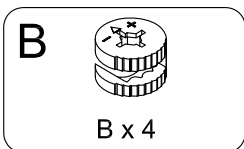
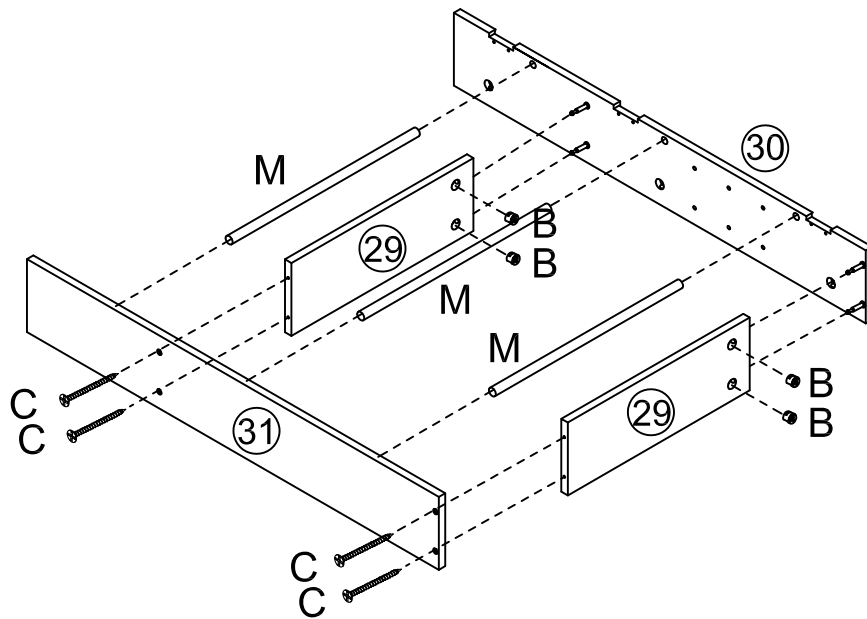

STEP 25

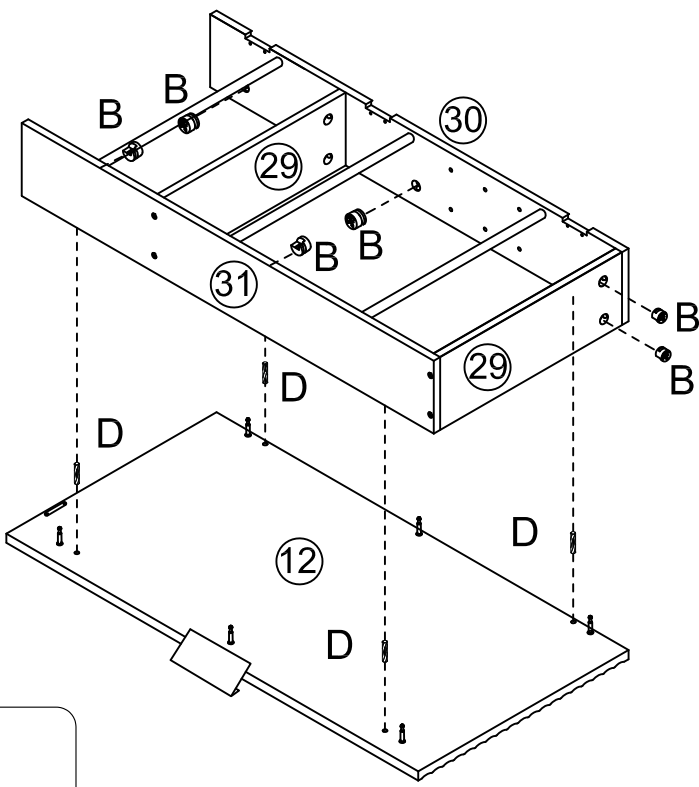

STEP 26





B 
B x 6

D 
D x 4

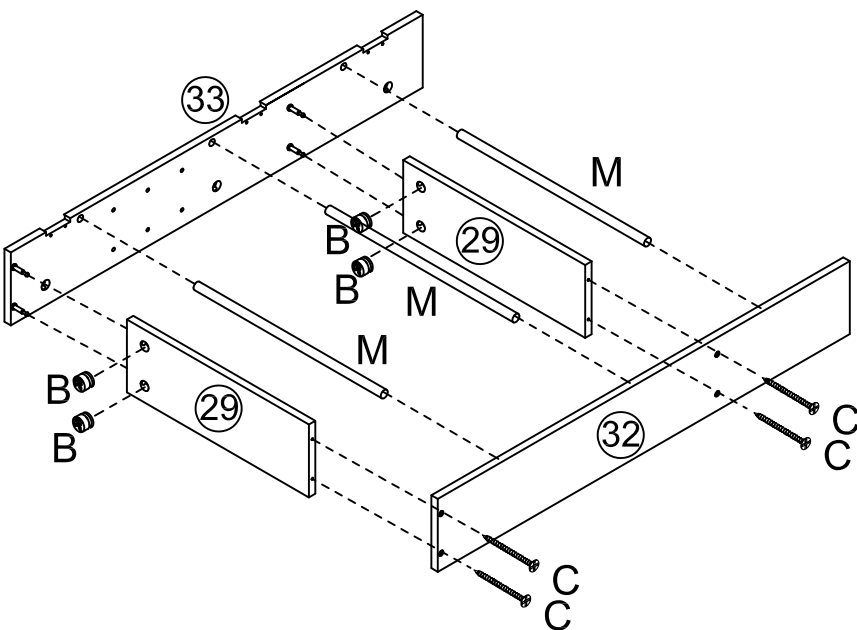
STEP 27



B 
B x 4

C 
M4 x 40 mm
C x 4

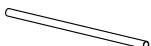
M 
M x 3

STEP 28

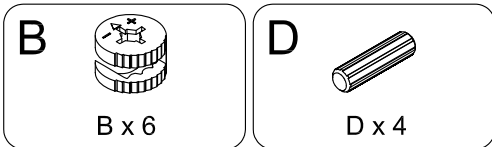
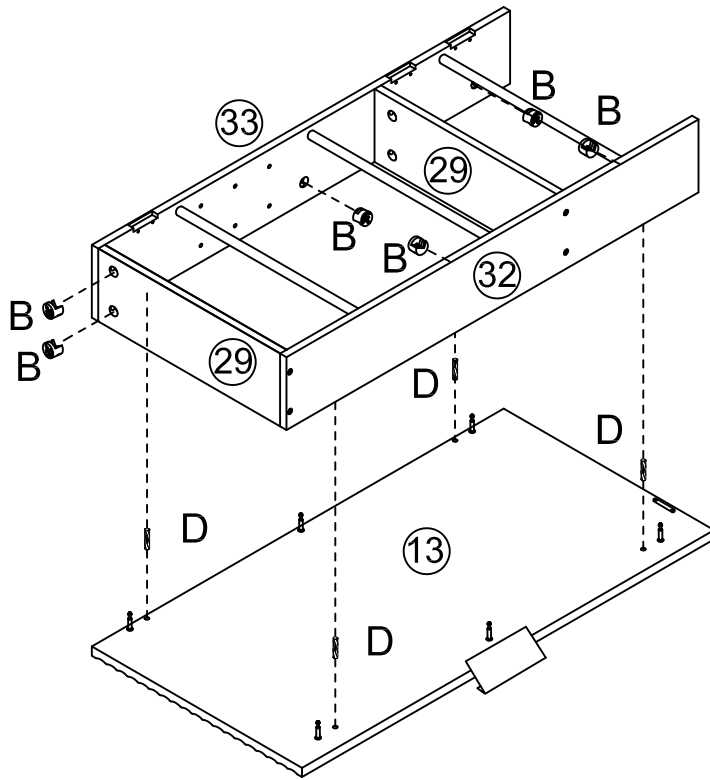

STEP 29

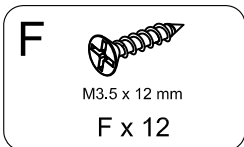
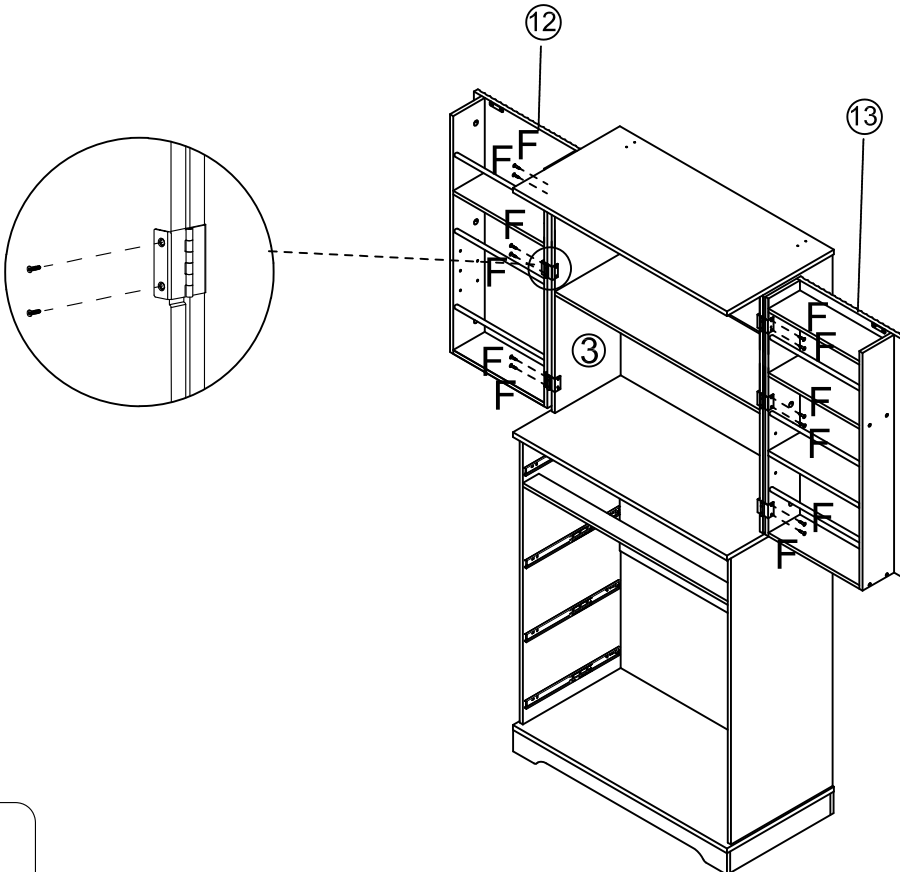

STEP 30

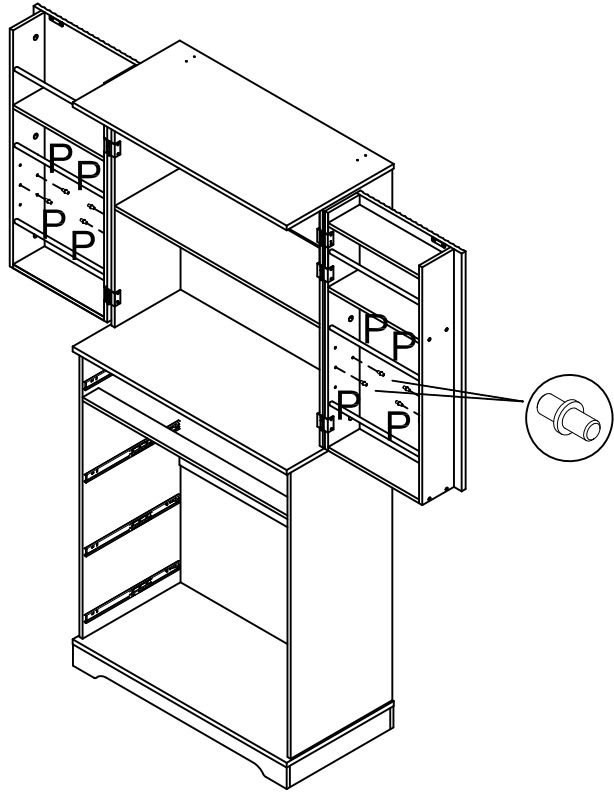

P



P x 8

STEP 31

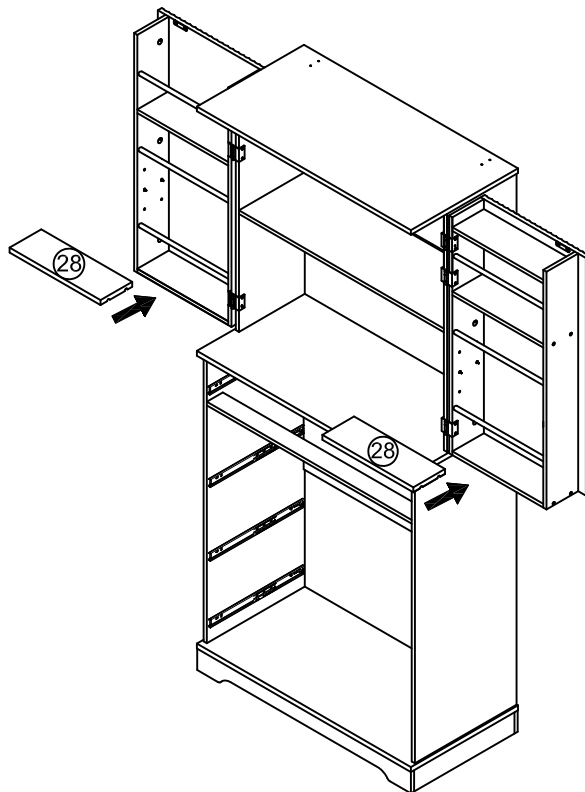

STEP 32

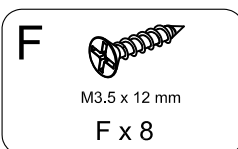
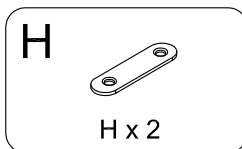
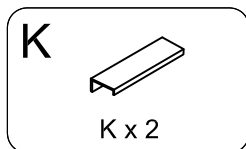
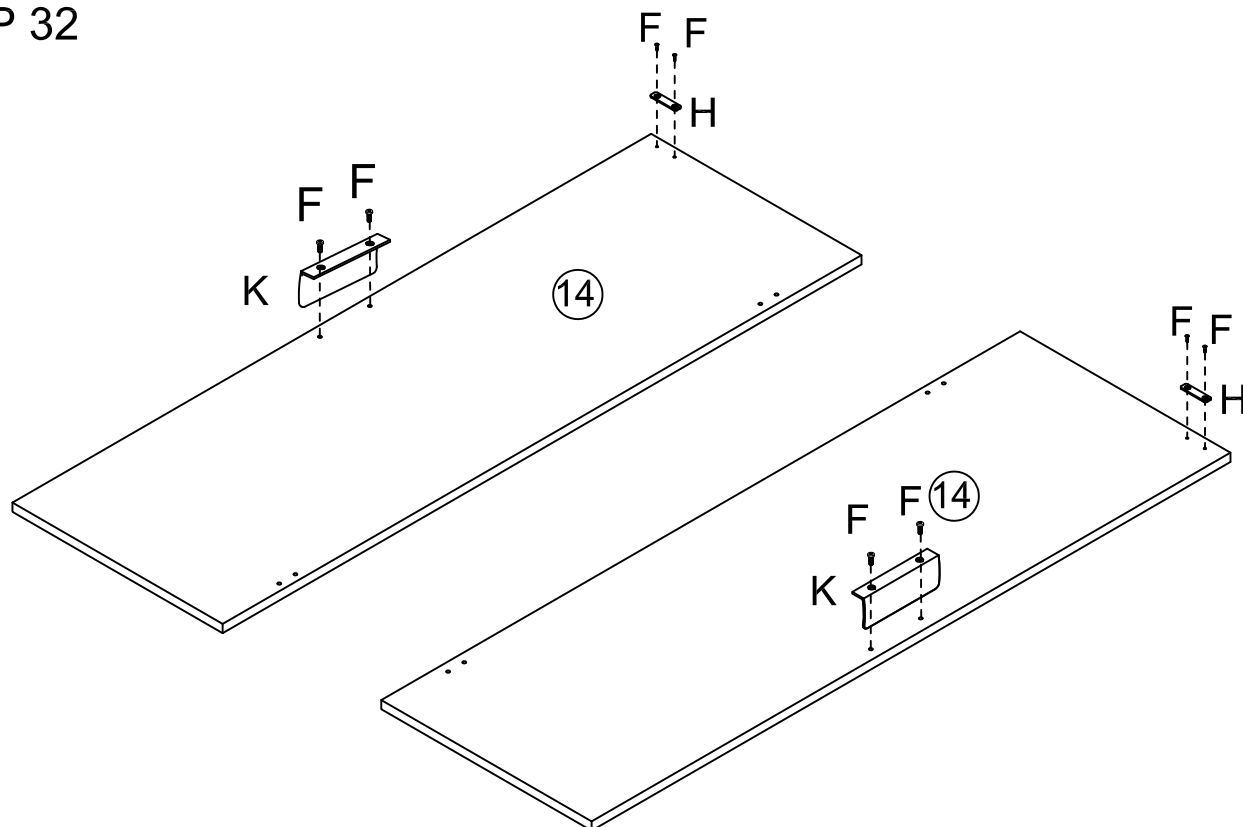

STEP 33

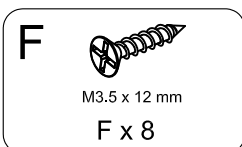
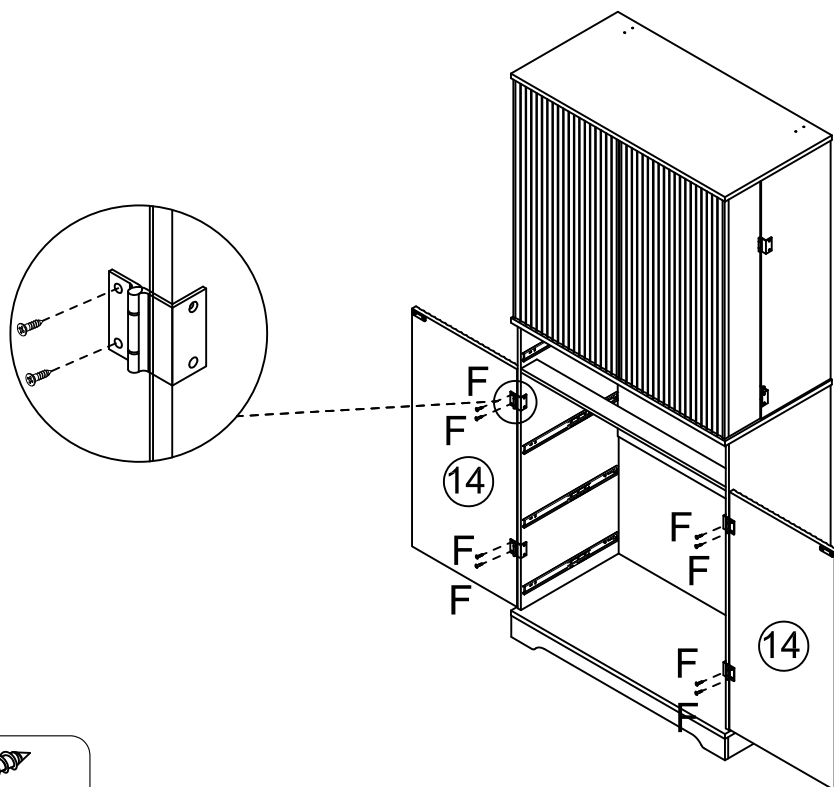

STEP 34

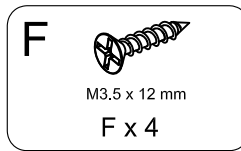
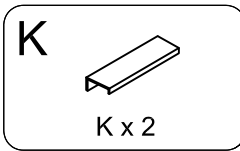
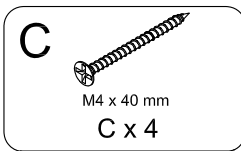
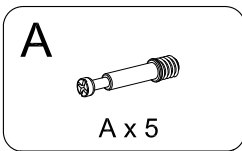
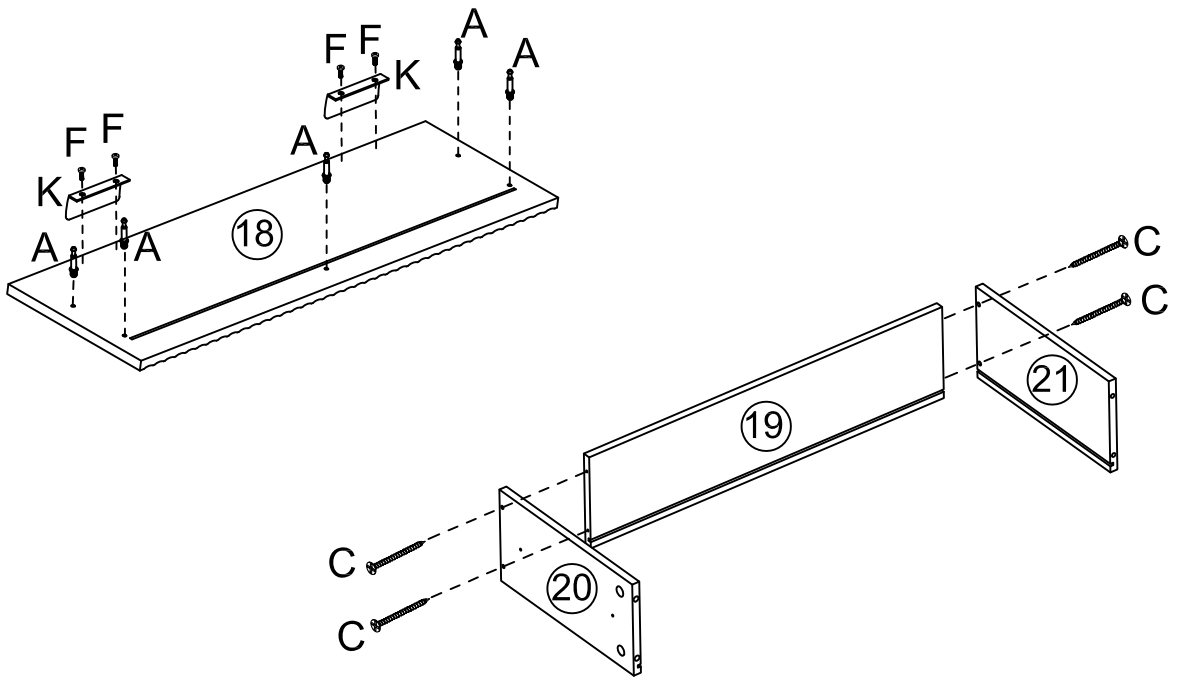

STEP 35

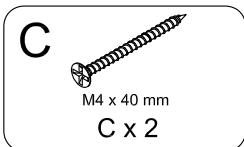
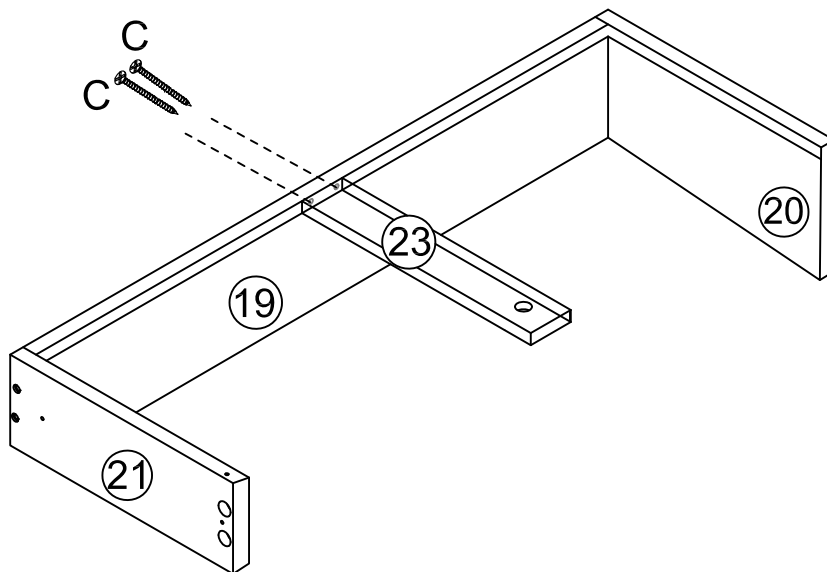

STEP 36

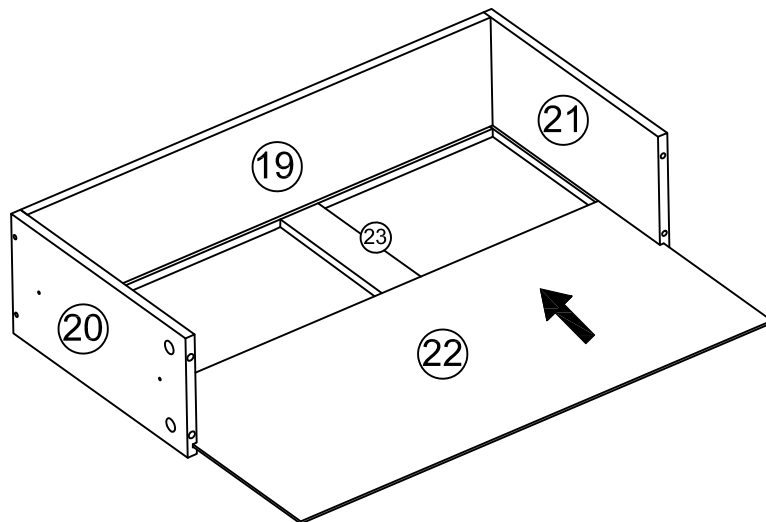

STEP 37

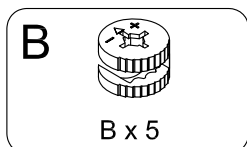
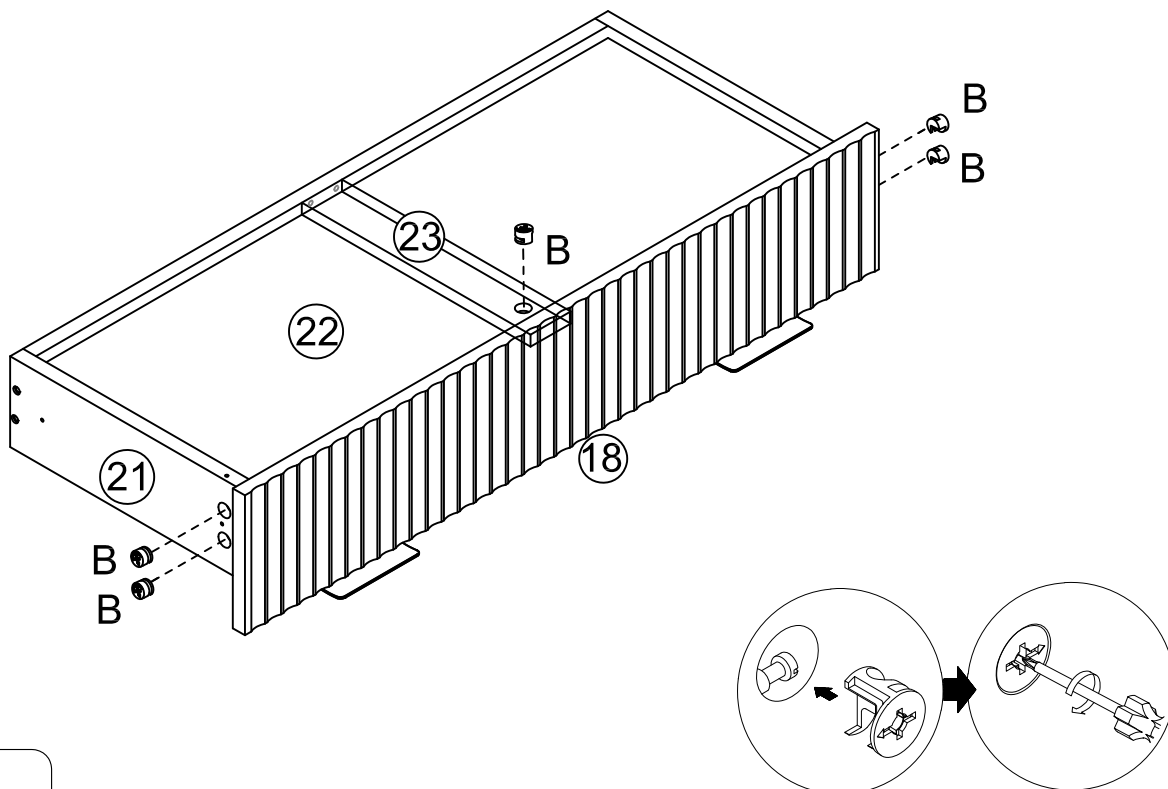

STEP 38

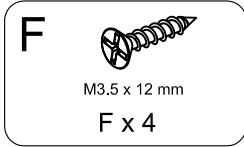
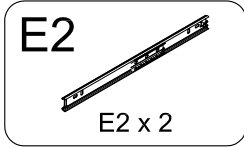
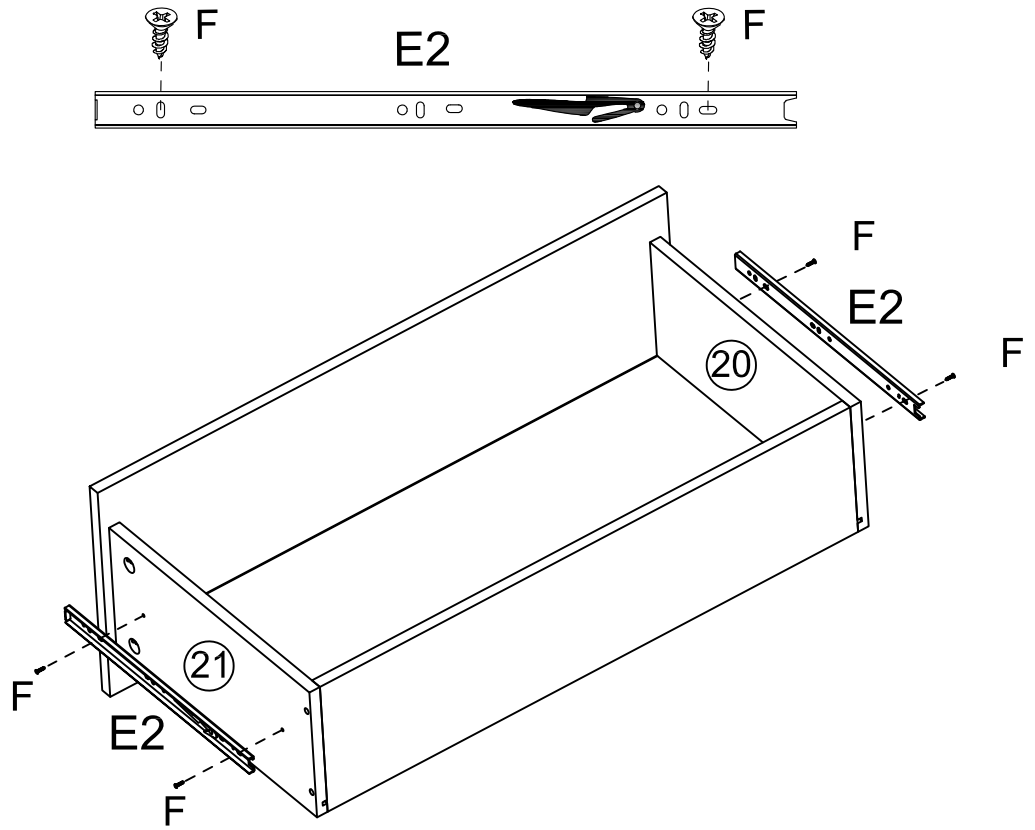

STEP 39

x 3

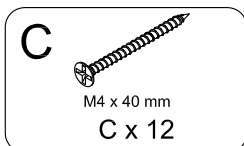
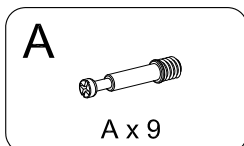
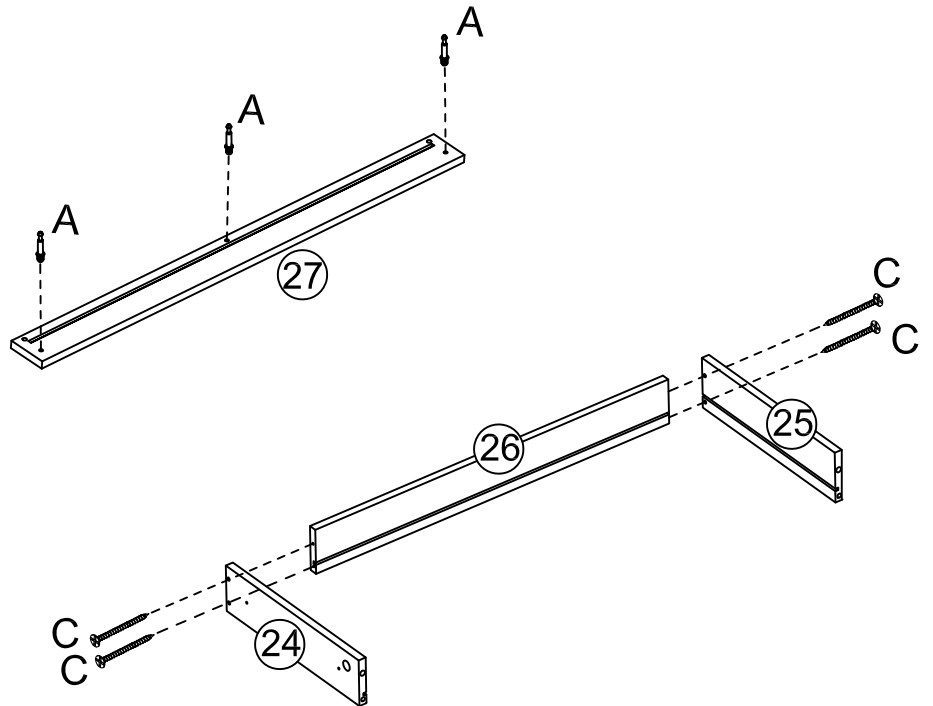

STEP 40

x 3

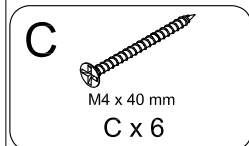
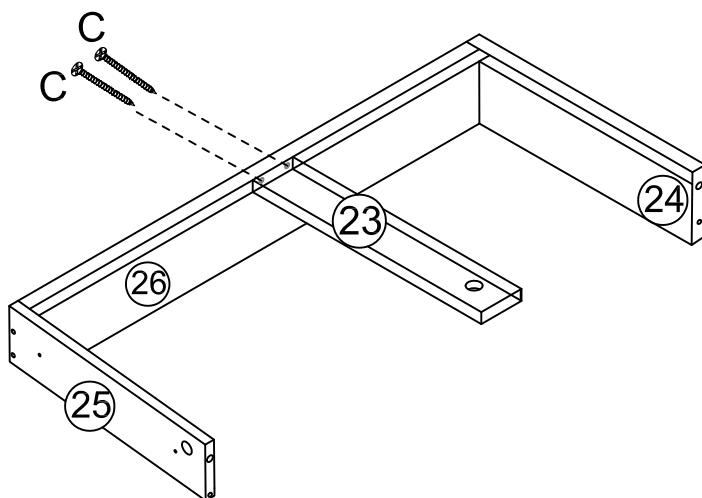

STEP 41

x 3

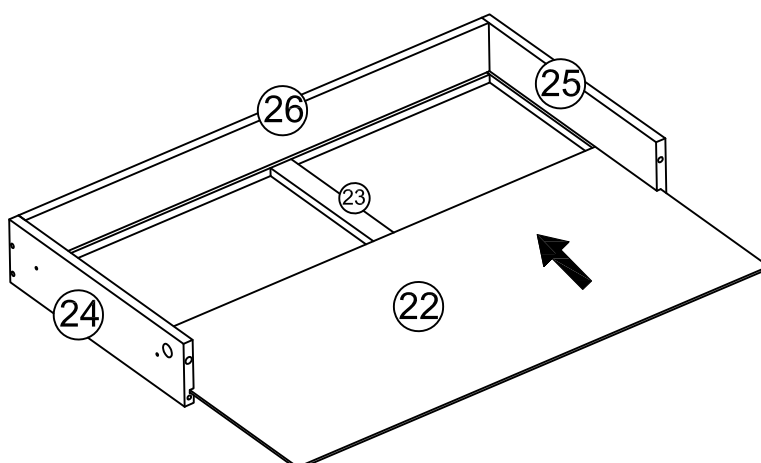

STEP 42

x 3

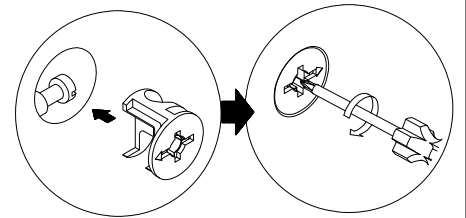
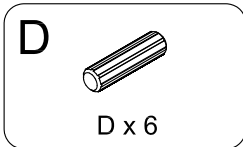
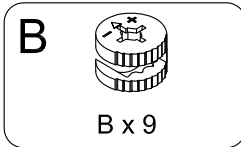
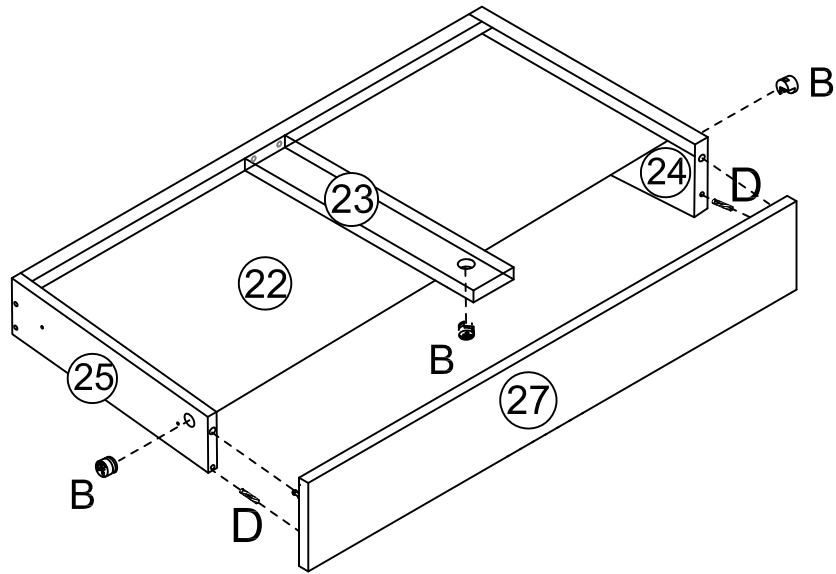

STEP 43

x 3

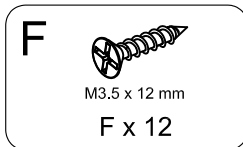
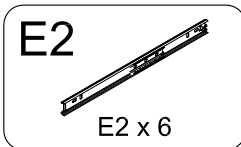
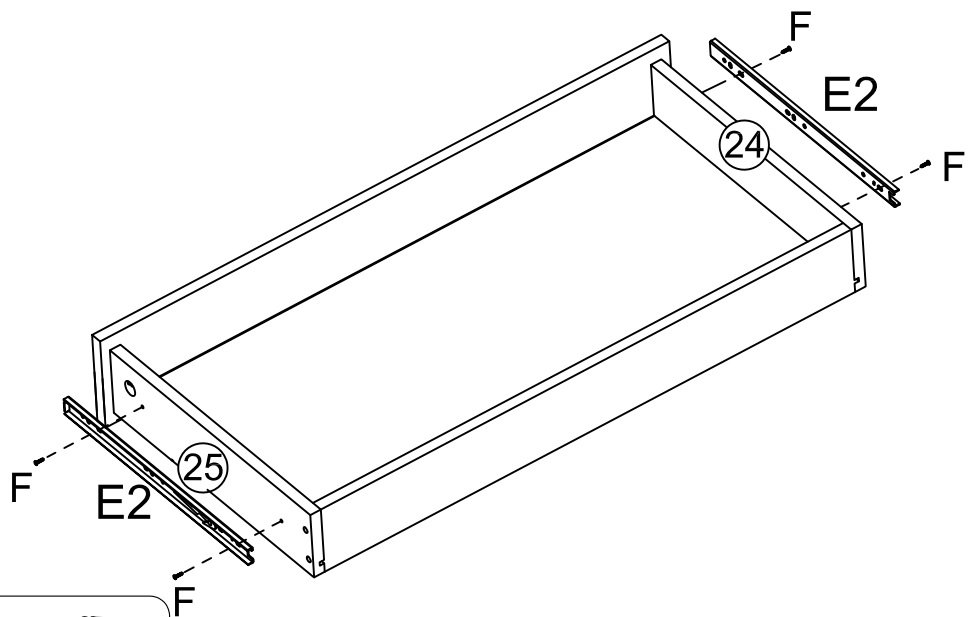
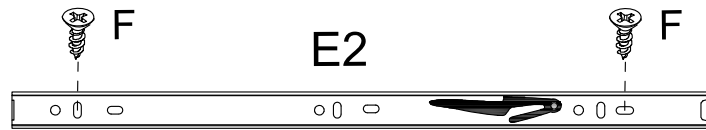

STEP 44

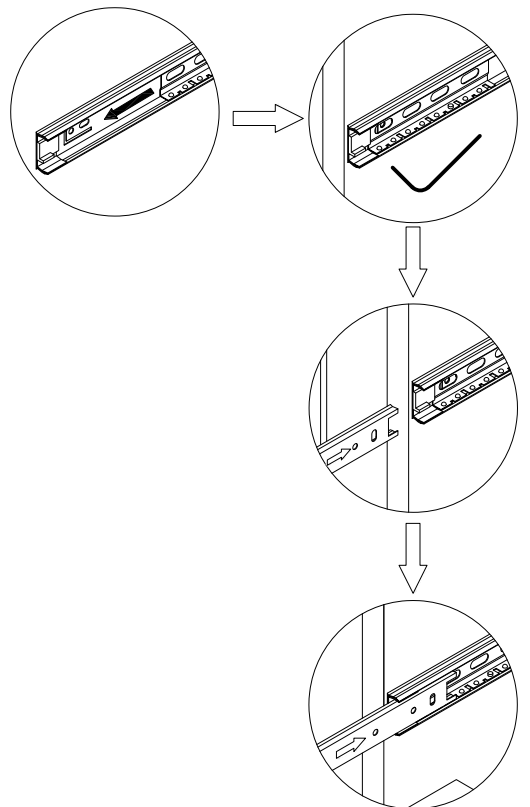
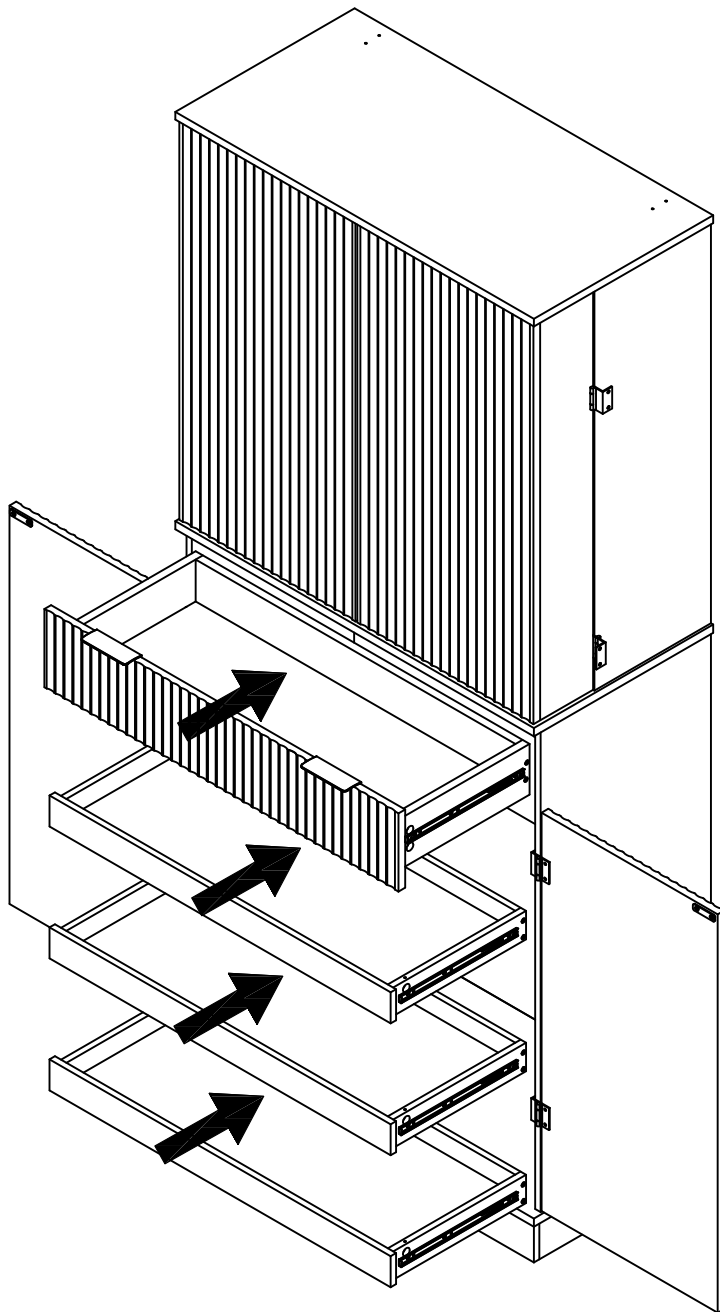

STEP 45

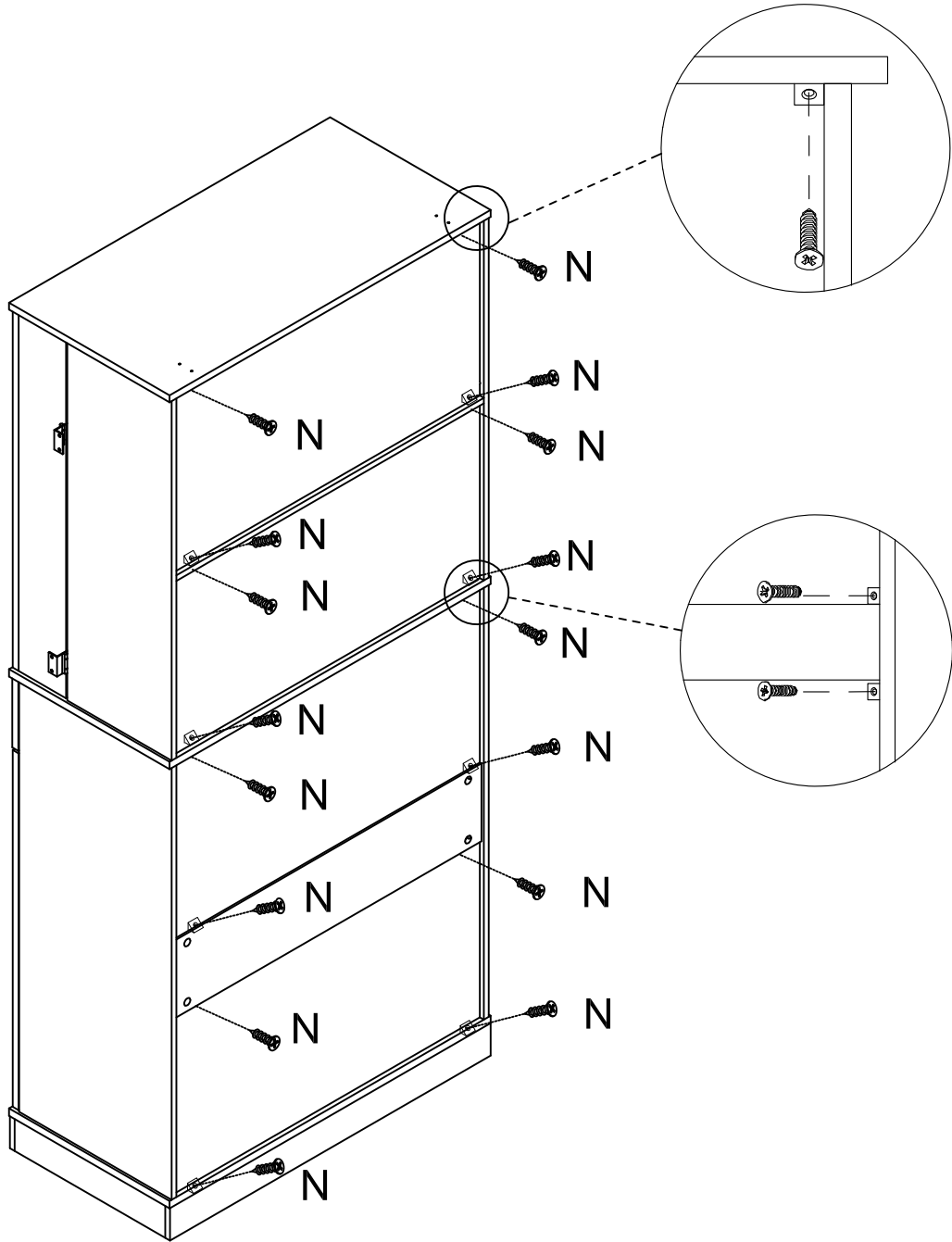

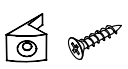

N

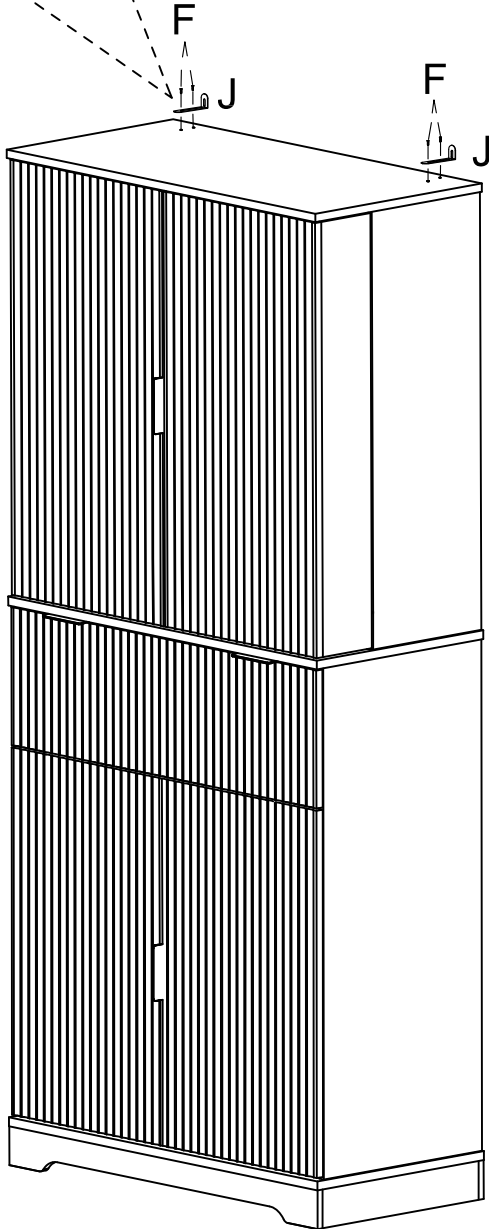
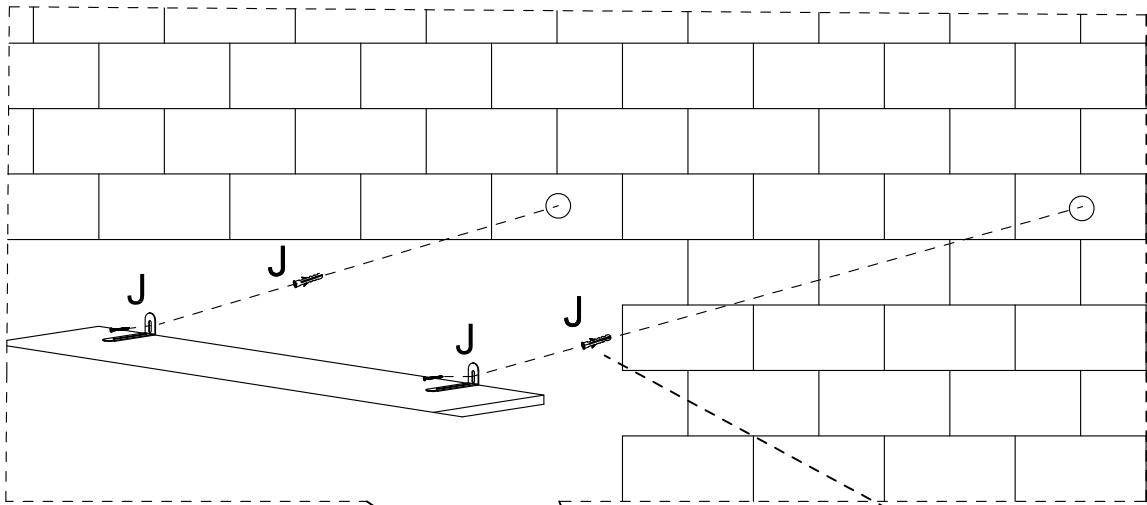

M3.5 x 16 mm
N x 16

STEP 46



J 
M4 x 40 mm
J x 2

F 
M3.5 x 12 mm
F x 4

COMPLETE

