







ASSEMBLY INSTRUCTION

CVFN4203

PARTS

S.NO.	DESCRIPTION	QTY
D	 MARBLE TOP	1
E	 WOODEN TOP	1
F	 LEG	1

HARDWARE

S.NO.	DESCRIPTION	QTY
A	 ALLEN BOLT 5x16mm	8
B	 SPRING WASHER 5mm	8
C	 WASHER 5mm	8
D	 ALLEN KEY 4mm	1

STEP -1

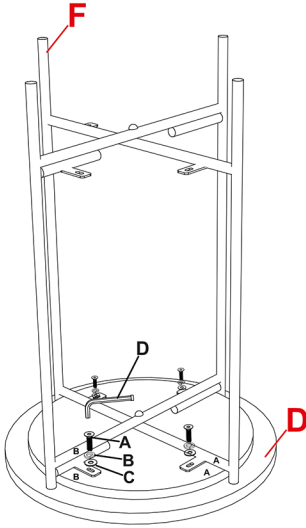

Note : Keep the marble top on soft surface.
Don't make bolt tighten until wooden top assembled.

STEP -2

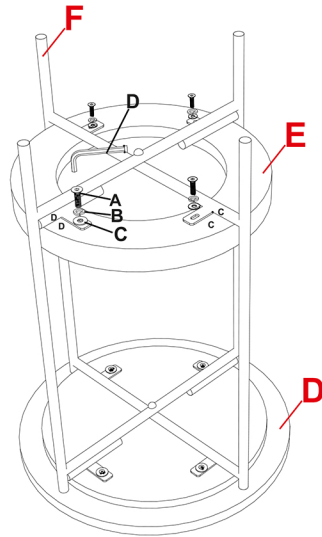

Note : Now all bolts can be tightened.

COMPLETED

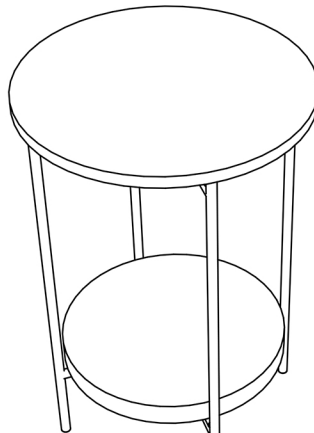

Adjust height for balance

