

We're here for you. Contact us at support.us@soforoom.com



X 2

Patio Dining Set

Model: TB101-US

NO.: YQ20251117

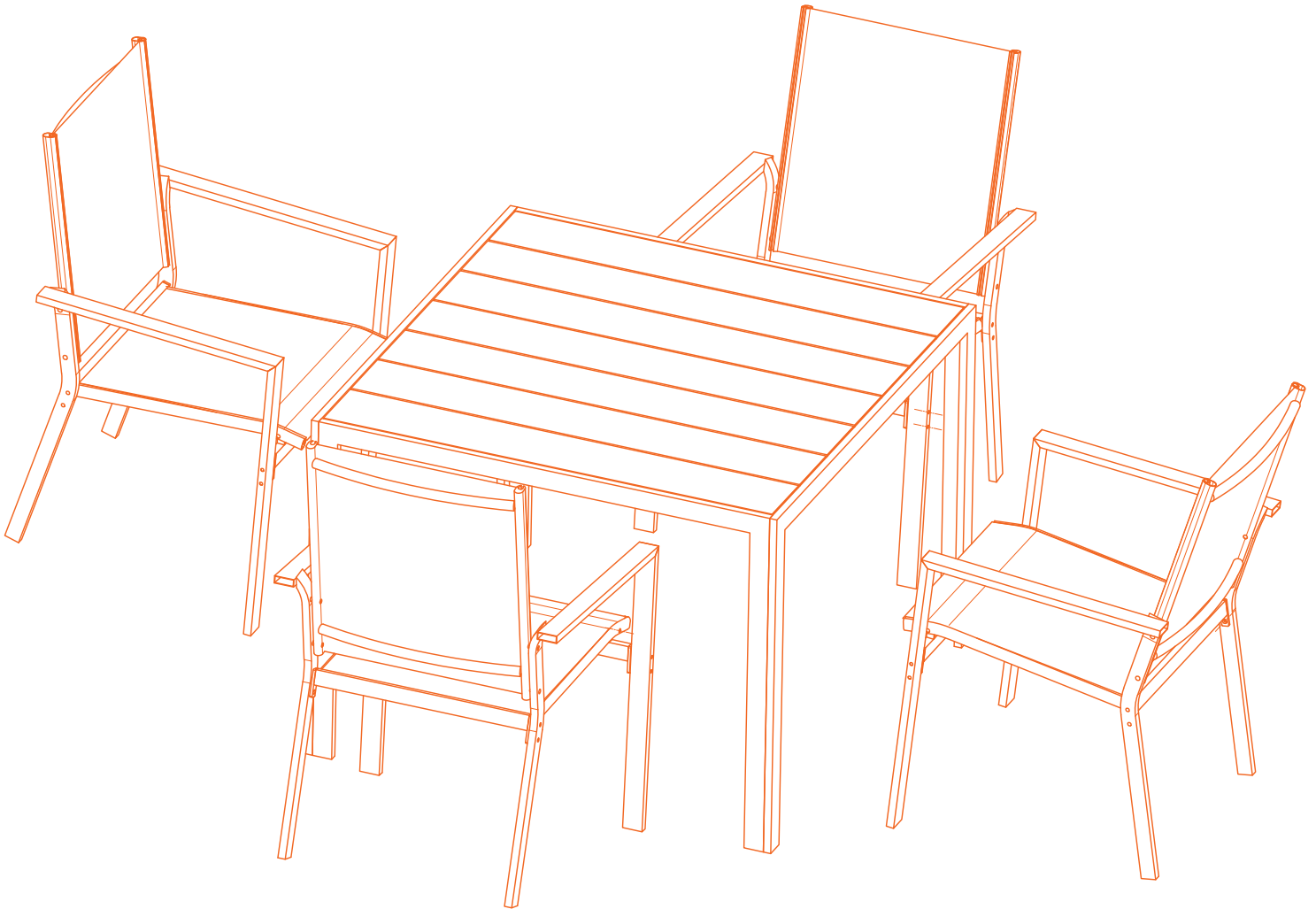

HELP CENTER

Have questions about this product? Contact us, and we'll assist you!

● Customer Support Email:

support.us@soforoom.com

* Upon receiving your email, we'll respond within **48** working hours.

CENTRO DE AYUDA

¿Tienes preguntas sobre tu producto? Ponte en contacto con nosotros y te ayudaremos.

- Correo electrónico de atención al cliente:

support.us@soforoom.com

*Al recibir tu correo electrónico, te responderemos en un plazo de **48** horas laborables.

WHAT DO YOU GET ?

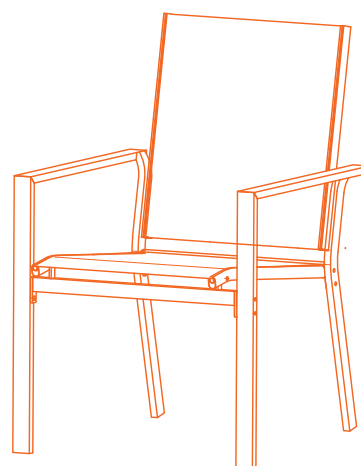
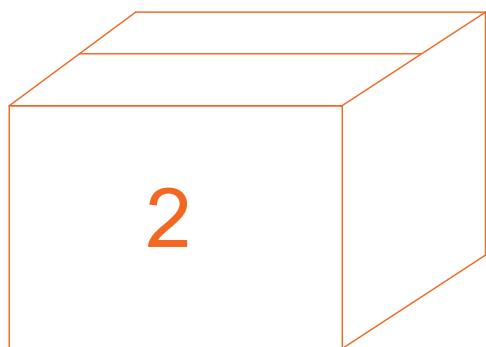
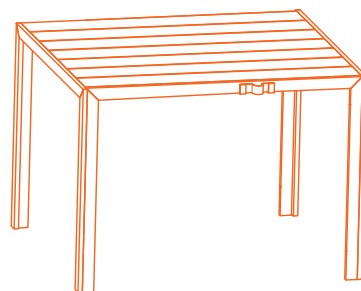
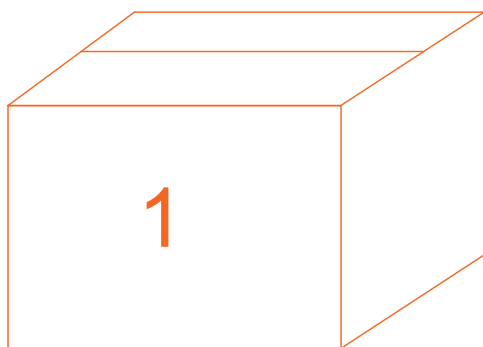

x 4

ATTENTION: THESE 2 BOXES MAY ARRIVE AT DIFFERENT TIMES,
PLEASE WAIT PATIENTLY.

FAQ

Q1: What should I do if the product I received is damaged or incorrect?

A1: If you've received a damaged, incorrect, or incomplete product, please reach out to our Customer Support Center at support.us@soforoom.com. Include your order number and photos.

Q2: What should I do if I encounter problems during installation?

A2: If you encounter any installation issues, please email to support.us@soforoom.com, attach a detailed description of the problem, we will provide you for professional technical support.

Q3: How do I apply a return?

A3: You can initiate a return within 30 days of purchase. Email us at support.us@soforoom.com with your order number and the reason for return. We'll guide you through the process.

Note:

- Please contact us before returning the product to avoid any complications.
- Ensure the product is returned in its original packaging with all accessories included.

PREGUNTAS FRECUENTES

P1: ¿Qué debo hacer si el producto que he recibido está dañado o es incorrecto?

R1: Si has recibido un producto dañado, incorrecto o incompleto, ponte en contacto con nuestro Centro de Atención al Cliente en support.us@soforoom.com. Incluye tu número de pedido y fotos que documenten el problema para que podamos ayudarte con la devolución o el cambio.

P2: ¿Qué debo hacer si encuentro problemas durante la instalación?

R2: Si tienes algún problema durante la instalación, por favor envía un correo electrónico a support.us@soforoom.com, adjuntando una descripción detallada del problema.

Te proporcionaremos soporte técnico profesional.

P3: ¿Cómo puedo solicitar una devolución?

R3: Puede iniciar una devolución en los 30 días siguientes a la compra. Envíenos un correo electrónico a support.us@soforoom.com con su número de pedido y el motivo de la devolución.

Te guiaremos a través del proceso.

Nota:

- Póngase en contacto con nosotros antes de devolver el producto para evitar complicaciones.
- Asegúrate de devolver el producto en su embalaje original y con todos los accesorios incluidos.

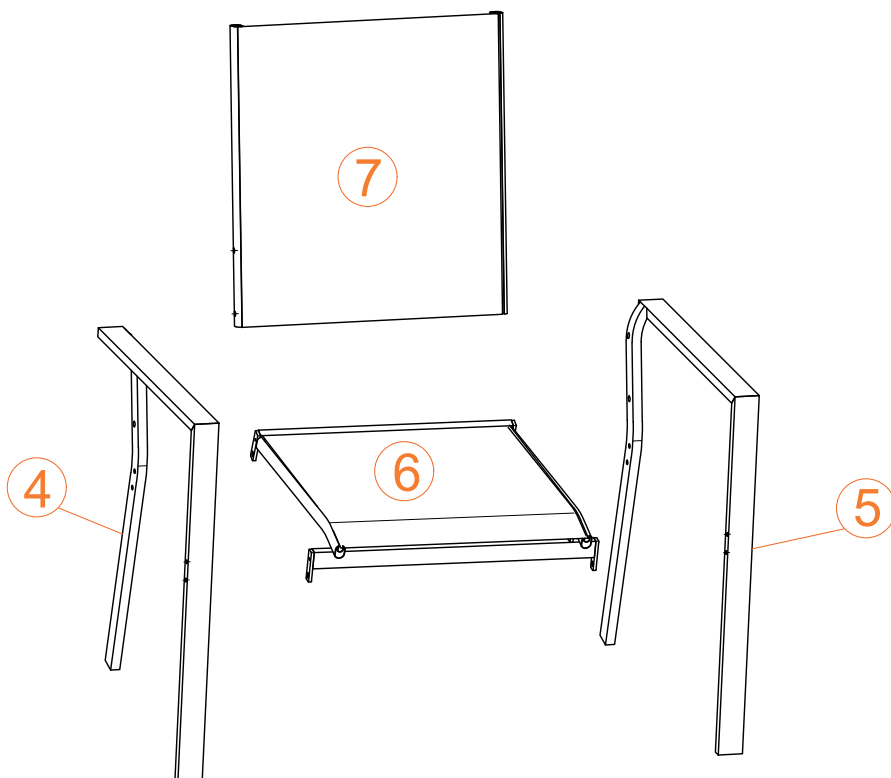
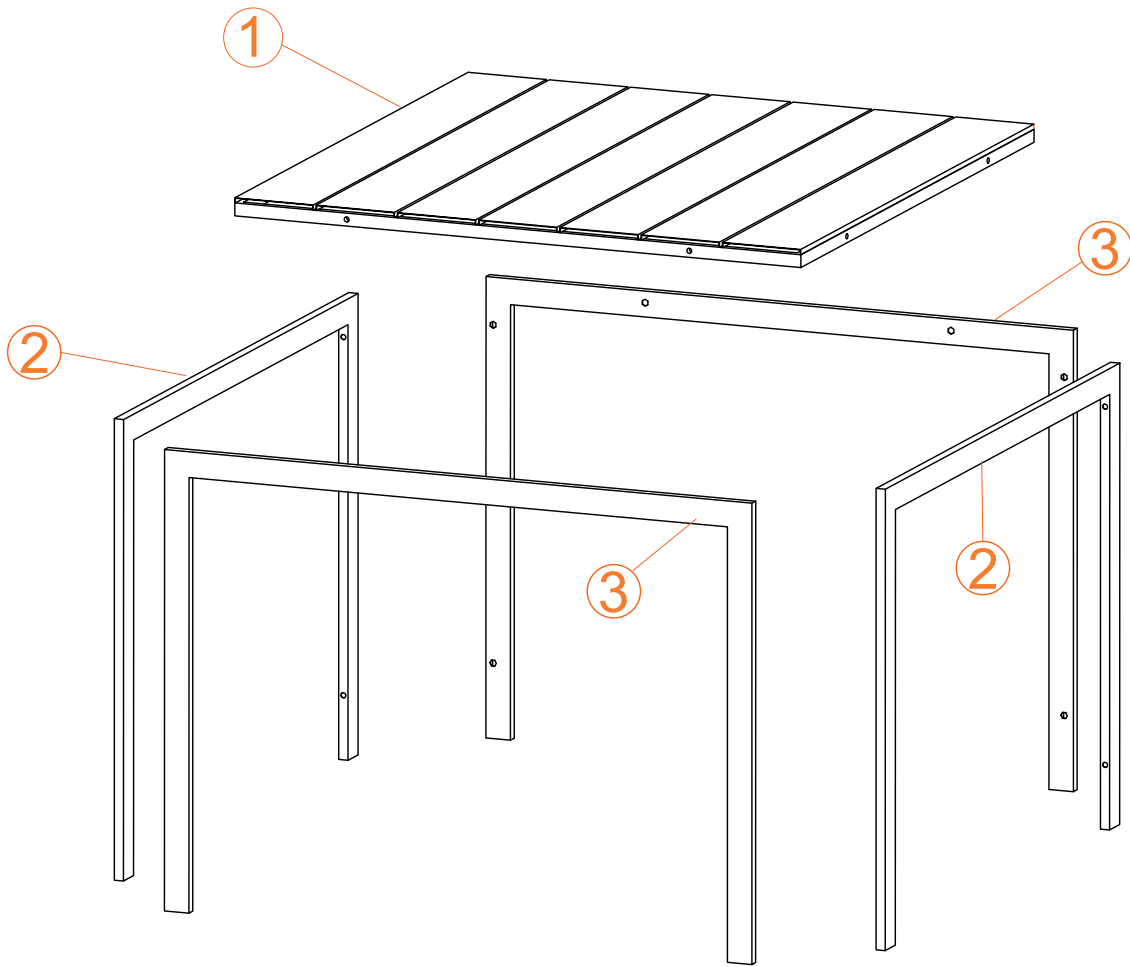

x 4

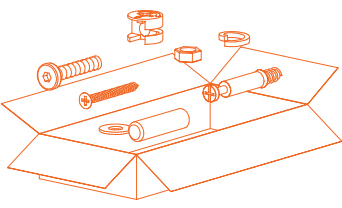

A x 1+1



M6

B x 1

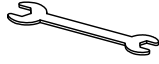

Wrench(M6-M8)

C x 8+1



Screw with washer
M6*25 mm

D x 32+2



Screw with washer
M6*30 mm

E x 24+2



Screw with washer
M6*50 mm

F x 16+1



M6

H x 2



I x 1

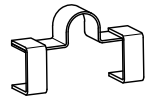

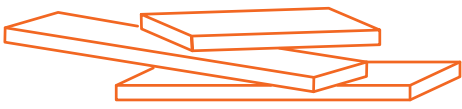

1 x1

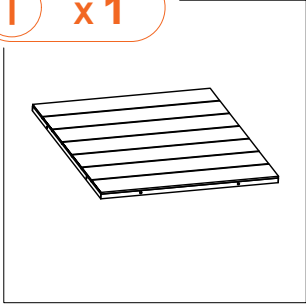

2 x2

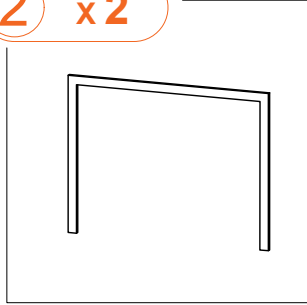

3 x2

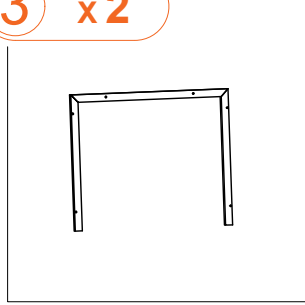

4 x4

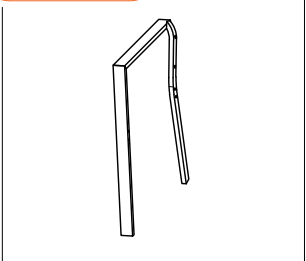

5 x4

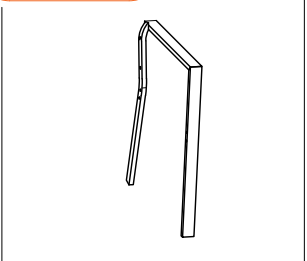

6 x4



7 x4

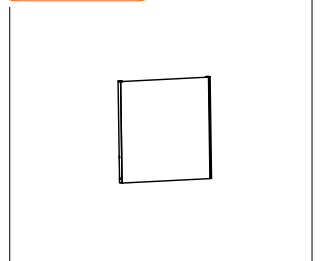

1

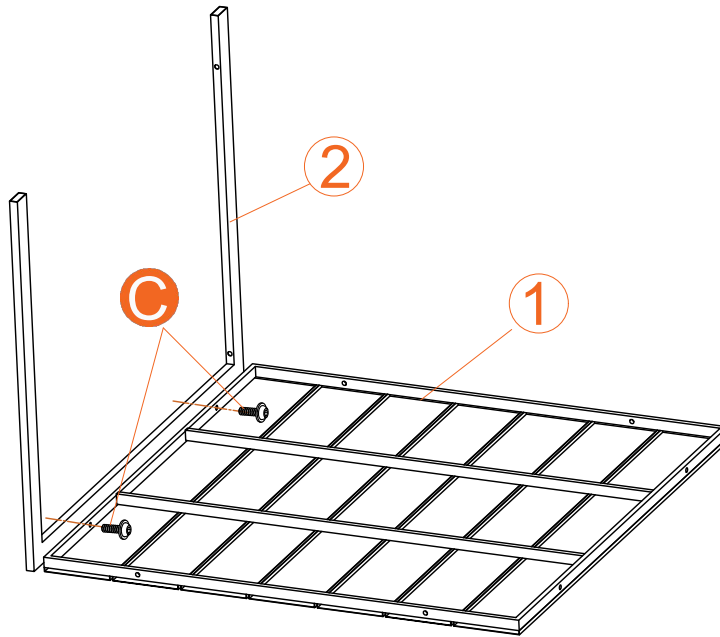
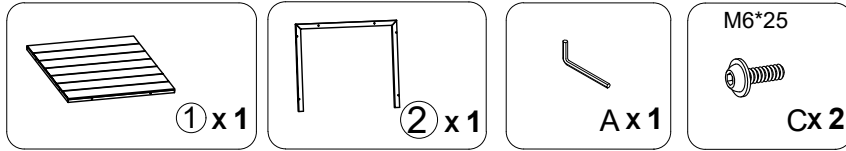

2

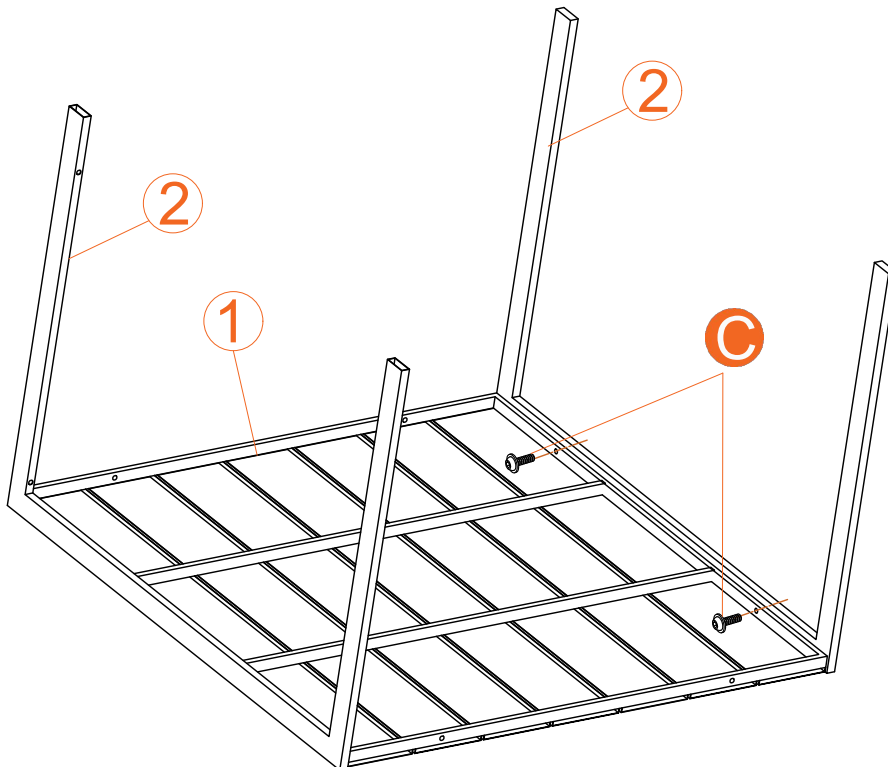
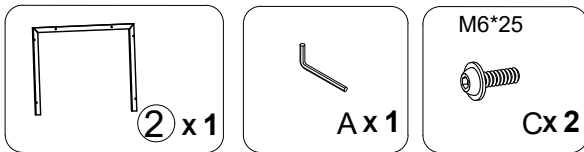

3

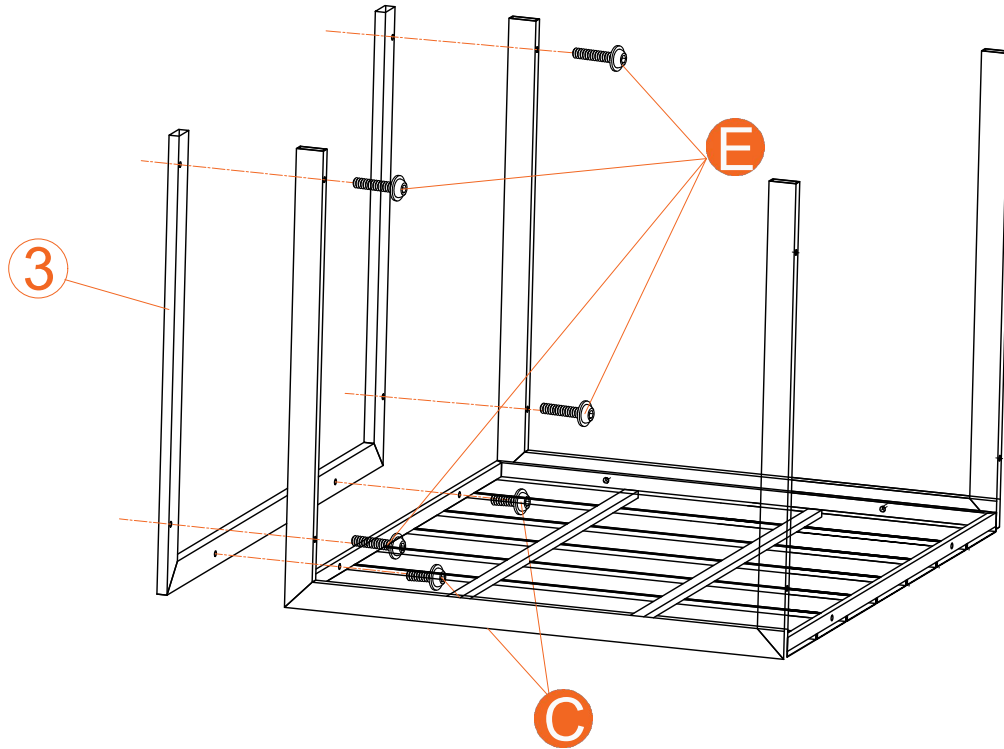
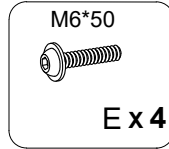
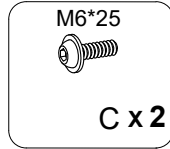
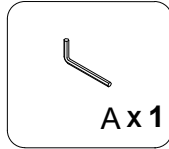
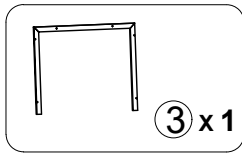

4

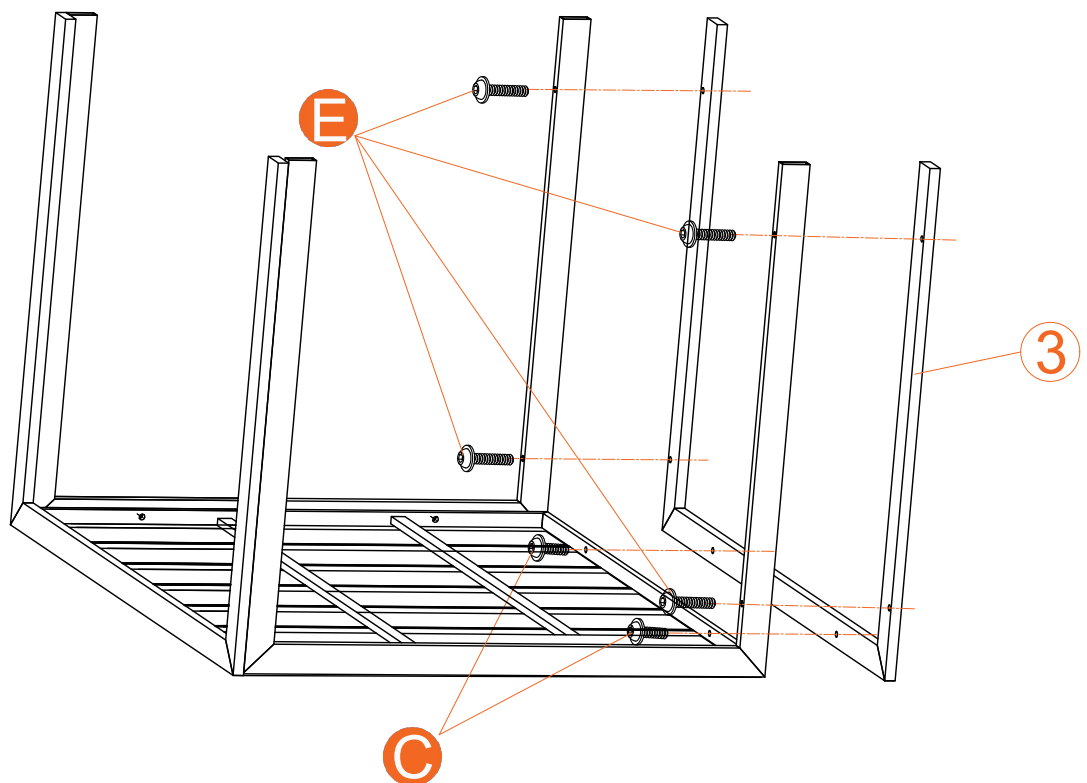
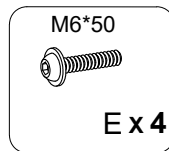
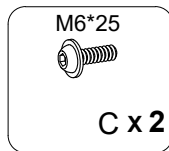
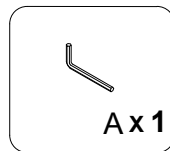
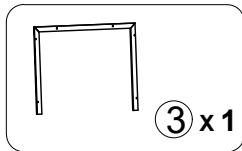

5

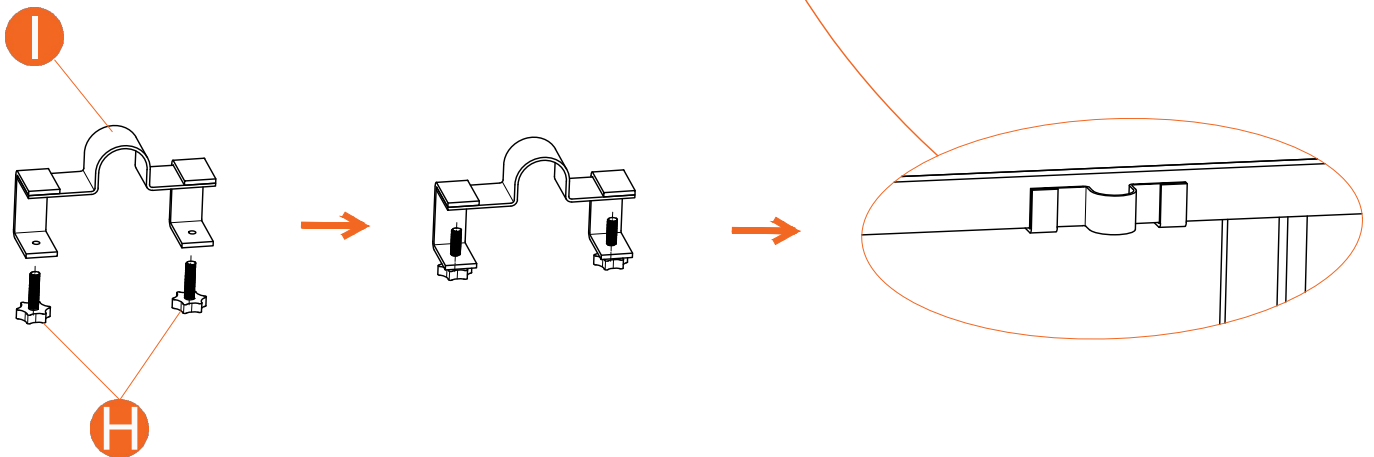
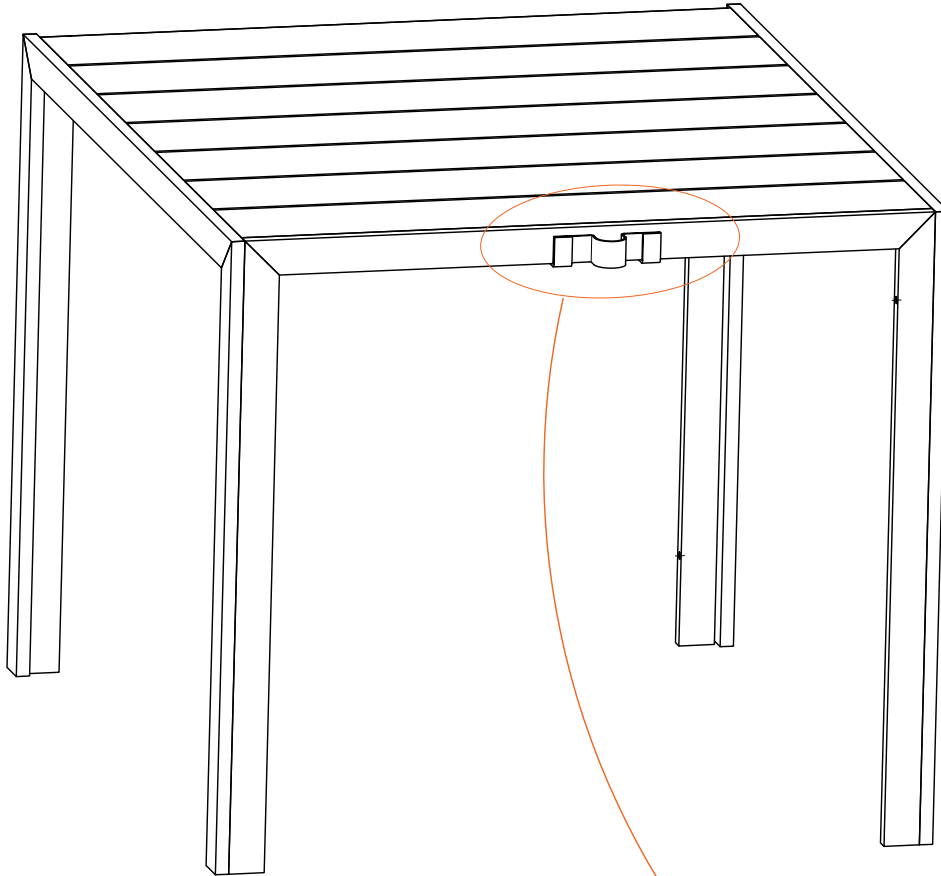
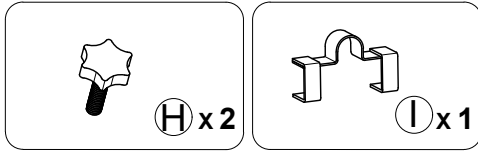

We offer a sunshade umbrella attachment that can be securely mounted on either side of a table to meet your needs.

6

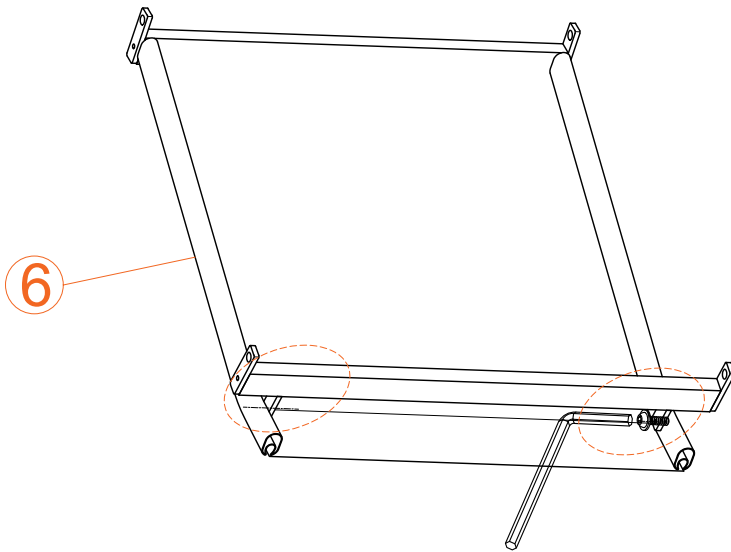
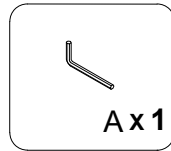
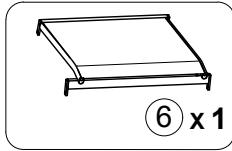

This part is pre-assembled and needs to be rescrewed during assembly

x 4

7

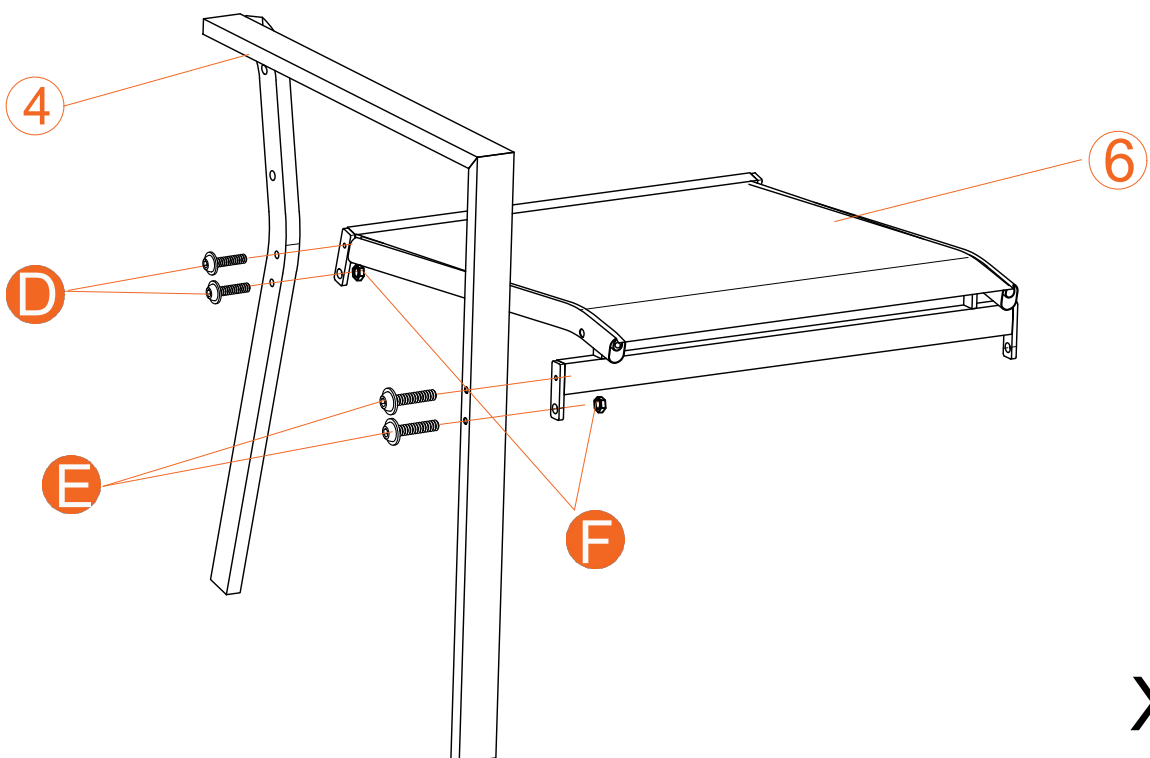
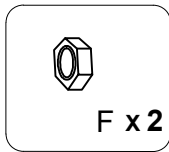
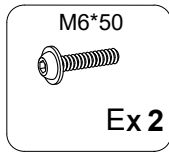
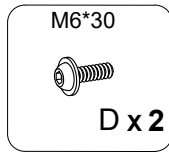
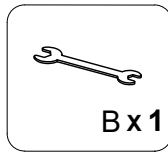
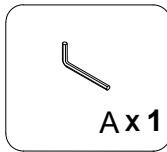
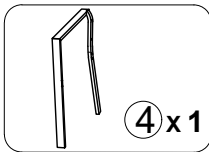

x 4

8

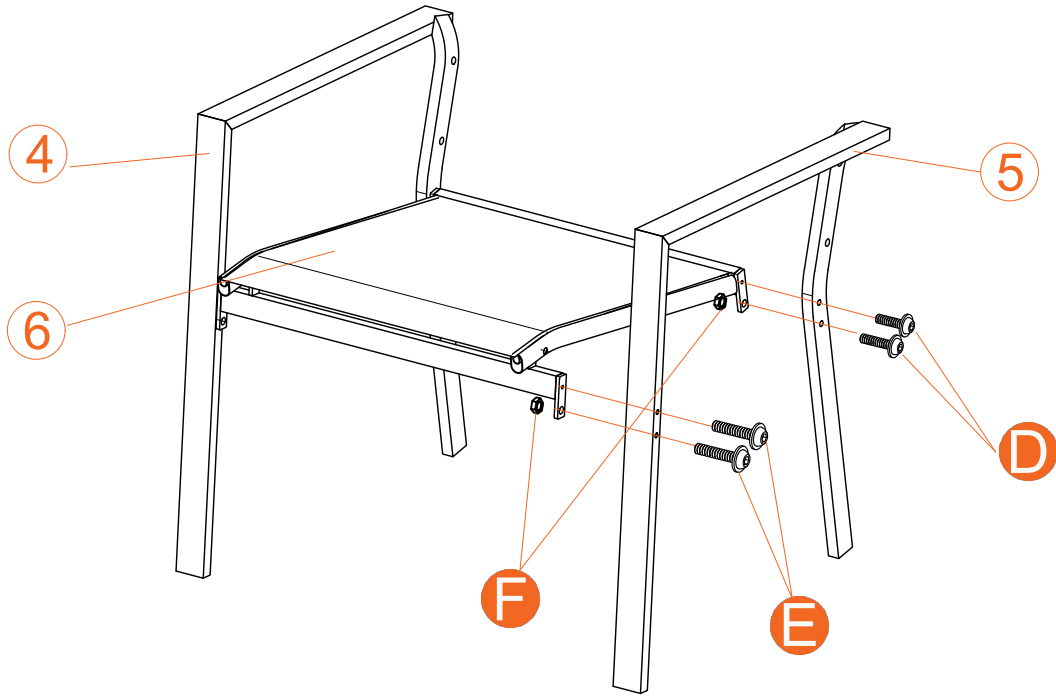
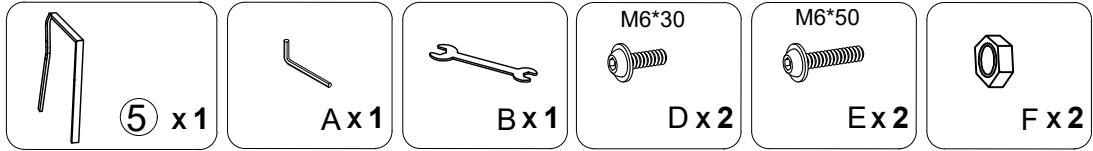

x 4

9

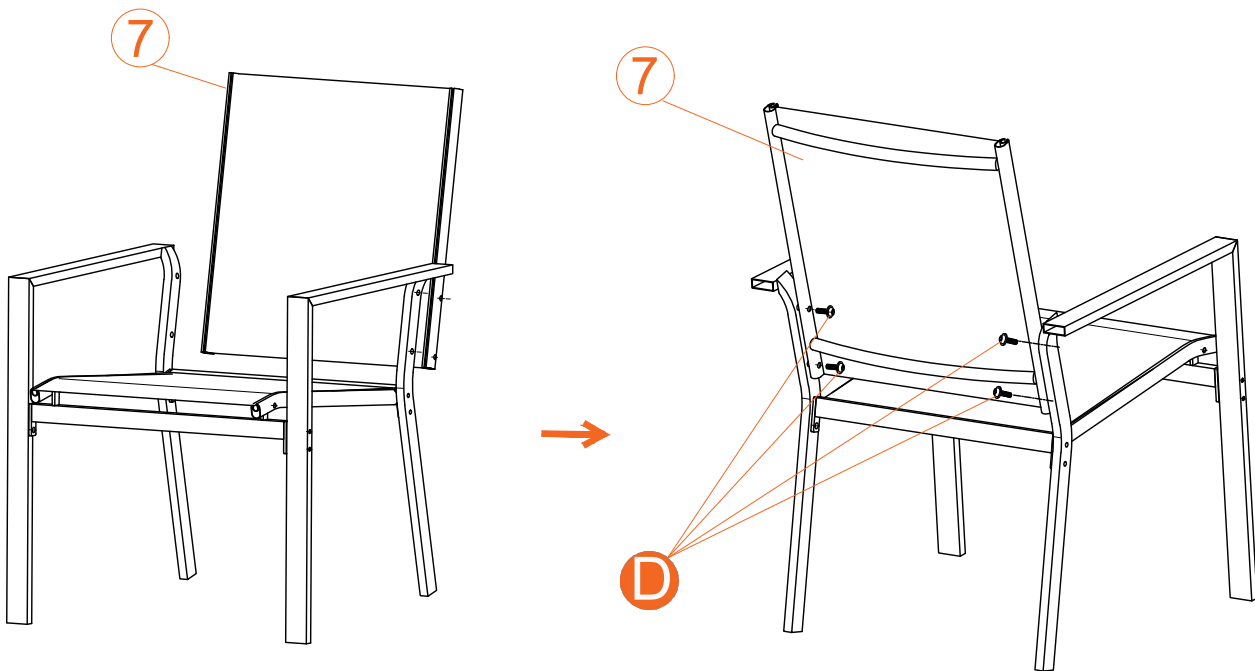
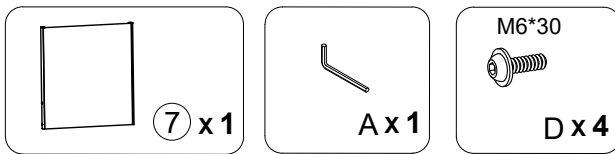

x 4

