

# ASSEMBLY INSTRUCTIONS

## MODEL: 3466-01 ELEANOR DINING TABLE (NATURAL)

Please read instructions carefully

Remove all wrapping materials, staples and packing straps from the carton.







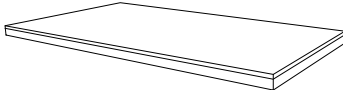

Refer to Parts List and Hardware List and ensure they are complete before you start assembling.

Place all wooden parts on a clean, flat and soft surface (e.g carpet or rug) to prevent parts from being scratched.

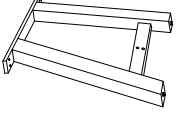
CAUTIONS:1) DO NOT FULLY TIGHTEN BOLTS AND NUTS UNTIL ALL PARTS HAVE BEEN ASSEMBLED.

2) DO NOT OVER-TIGHTEN BOLTS AND NUTS .

3) KEEP ALL HARDWARE PARTS OUT OF REACH OF CHILDREN.

| Designation           | Part | Qty  | Part List   | Hardware | Qty  | Hardware List  |
|-----------------------|------|------|---|----------|------|--|
| TABLE TOP             | P1   | 1PC  |    | H1       | 8PCS | BOLT<br>Ø5/16" x 38mm           |
|                       |      |      |   | H2       | 4PCS | BOLT<br>Ø1/4" x 70mm            |
| TABLE LEGS            | P2   | 2PCS |    | H3       | 8PCS | SPRING WASHER<br>Ø5/16" x 13mm  |
|                       |      |      |   | H4       | 8PCS | FLAT WASHER<br>Ø5/16" x 19mm    |
| TABLE LONG STRETCHER  | P3   | 1PC  |   | H5       | 2PCS | SCREW<br>Ø4" x 40mm           |
| TABLE SHORT STRETCHER | P4   | 2PCS |  | H6       | 1PC  | ALLEN KEY<br>M4 x 59mm        |

### COMPLETE ASSEMBLY

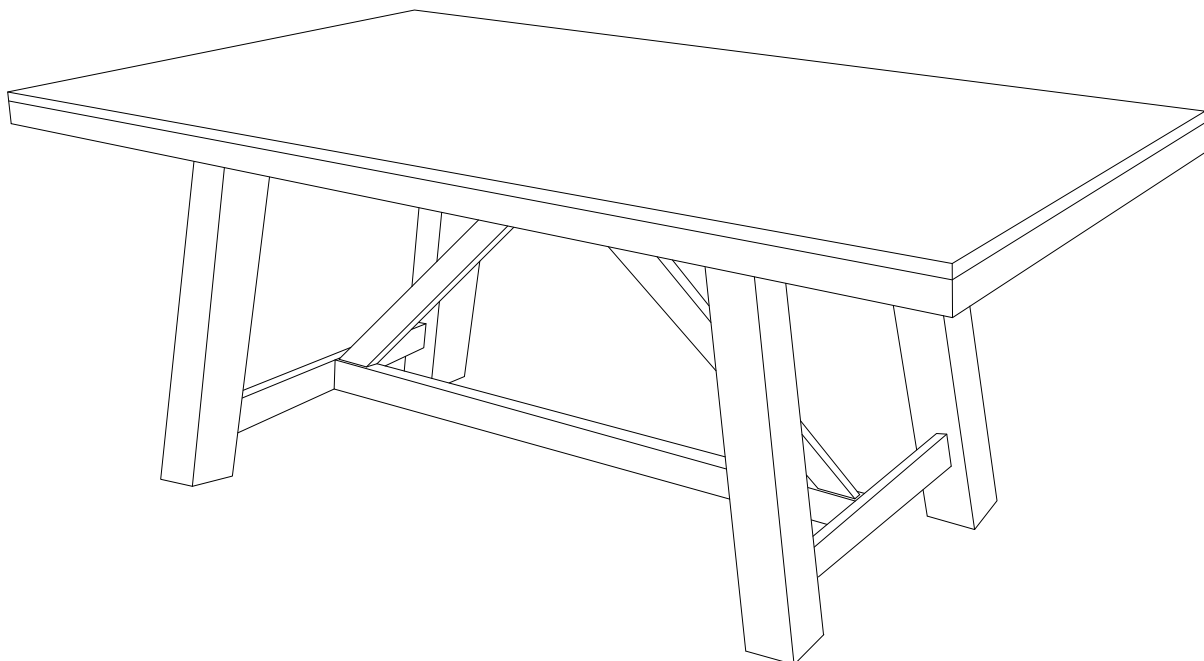

# ASSEMBLY INSTRUCTIONS

## MODEL: 3466-01 ELEANOR DINING TABLE (NATURAL)

### STEP 1

Prepare the TABLE LONG STRETCHER (P3) and TABLE SHORT STRETCHER (P4). Connected together by two wooden pegs fixed to TABLE SHORT STRETCHER (P4) and additional bolts are attached to make them more secure.

Align the BOLT (H2) through the connecting block holes. See image below.  
Tighten all bolts with ALLEN KEY (H6).

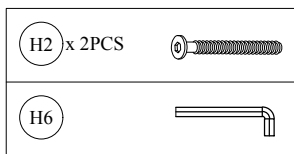
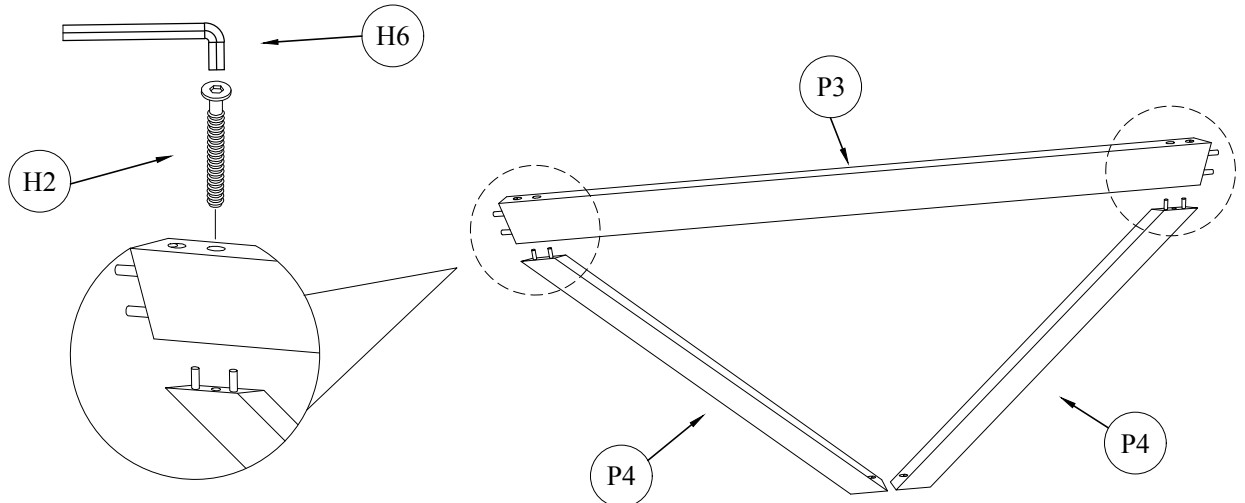

### STEP 2

Prepare the TABLE TOP (P1) by placing it upside-down on a flat, soft & clean surface  
Assemble TABLE LEGS (P2) by attaching it to the connecting blocks in the TABLE TOP.

Align BOLT (H1) fitted with a SPRING WASHER (H3) & a FLAT WASHER (H4) through the connecting block holes.  
See image below.  
Tighten all the bolts with ALLEN KEY (H6).

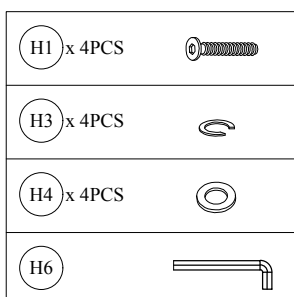
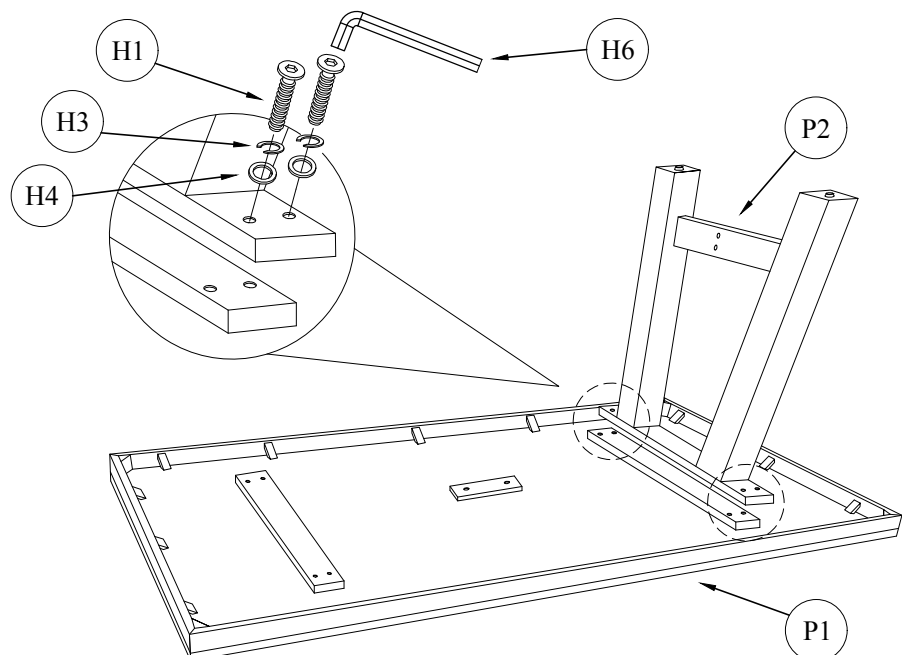

# ASSEMBLY INSTRUCTIONS

## MODEL: 3466-01 ELEANOR DINING TABLE (NATURAL)

### STEP 3

Align the assembled STRETCHERS (P3), (P4) completed in STEP 1 so that they connect to the TABLE TOP (P1) and TABLE LEGS (P2). Use the wooden peg from the LONG STRETCHER and connect it with the Legs.

Align the BOLT (H2) through the connecting block holes. See image below.  
Tighten all bolts with the ALLEN KEY (H6).

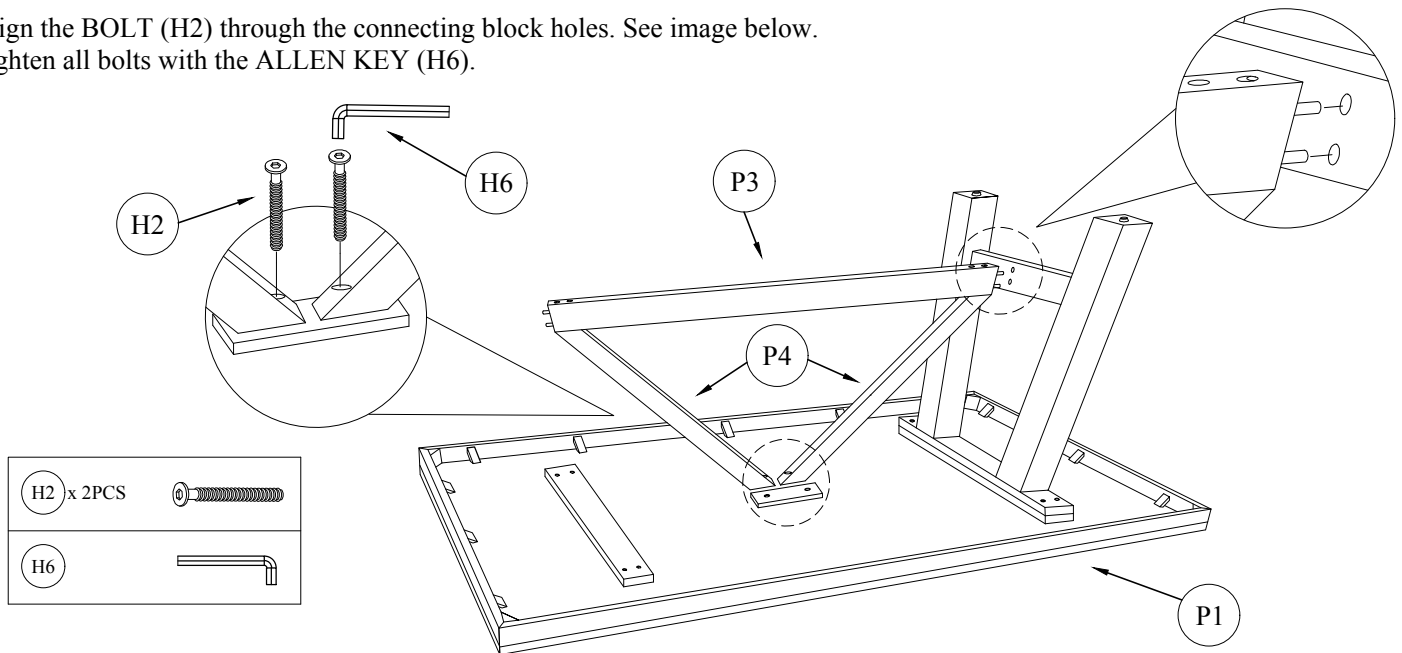

### STEP 4

Repeat STEP 2 and STEP 3. To connect the other set of legs to the other side of the table.

After installing the BOLT in the fixed positions, we proceed to screw the SCREW (H5) so that the leg frame is connected to the leg without any clearance. Repeat this on the other side of the STRETCHER, to secure on both sides of the Legs. This will fix and secure the STRETCHER.

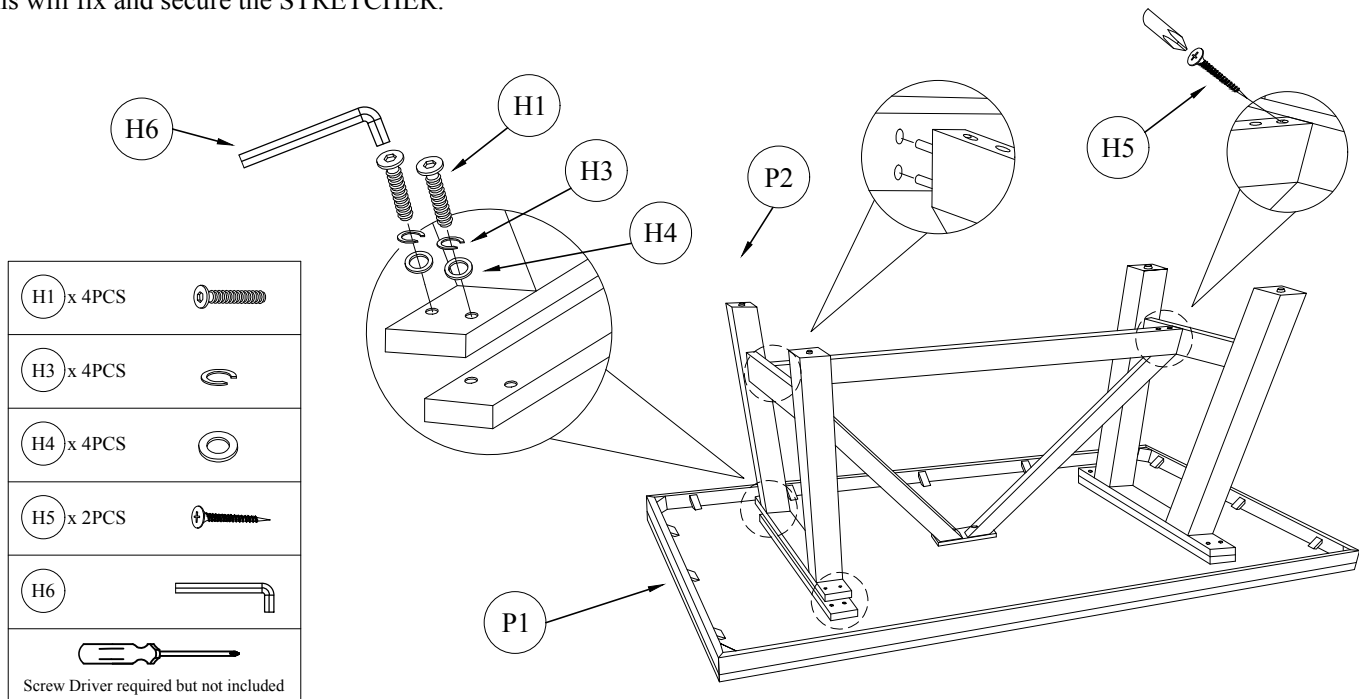

Carefully reposition the Table Upright with the help of Two or more adults.

### CARE AND MAINTENANCE

**SAFETY** - To avoid any risk of suffocation to children or animals, dispose off the plastic bags immediately.

**CLEANING** - Clean with damp cloth and mild detergent. Do not use bleach or abrasive products.

**FITTINGS** - Tighten bolts and nuts from time to time to ensure all parts of product are securely fitted.