

## CARE AND MAINTENANCE

Store outdoor furniture indoors or cover well when not in use.  
Remove wooden furniture from standing water. Dust regularly with small brush or vacuum  
Spills should be taken care of immediately before they harden or stain with a slightly dampened sponge.

## NOTICE



















- \* Please make sure that you have all parts indicated before you begin assembly of this item
- \* This item should be assembled on a soft surface to prevent scratching the finish during assembly
- \* This item may require periodic tightening

**Weight Capacity : 275 lbs (single seat)  
550 lbs (two person seat)**

**Warning : Do not stand on bench  
Warning : Do not over torque bolts/screws**



Part List and Hardware List

PIECE	DESCRIPTION	PICTURE	QUANTITY
1	RIGHT FRAME		3 X
2	LEFT FRAME		3 X
3	BACK CHAIR		2 X
4	SEAT CHAIR		2 X
5	BACK BENCH		1 X
6	SEAT BENCH		1 X
7	LEG TABLE		2 X
8	SUPPORT BAR		1 X
9	TOP TABLE FRAME		1 X
10	BACK CHAIR CUSHION		2 X
11	SEAT CHAIR CUSHION		2 X
12	BACK BENCH CUSHION		1 X
13	SEAT BENCH CUSHION		1 X
14	TABLE GLASS		1 X
A	BOLT M6 x 55 MM		6 X
B	BOLT M6 x 35 MM		26 X
C	BOLT M6 x 15 MM		4 X
D	FLAT WASHER		36 X
E	ALLEN KEY		2 X

## Product Dimension:

41.34"x19.69"x16.34" (TABLE)  
42.91"x26.57"x30.71" (BENCH)  
23.23"x26.57"x30.71" (CHAIR)

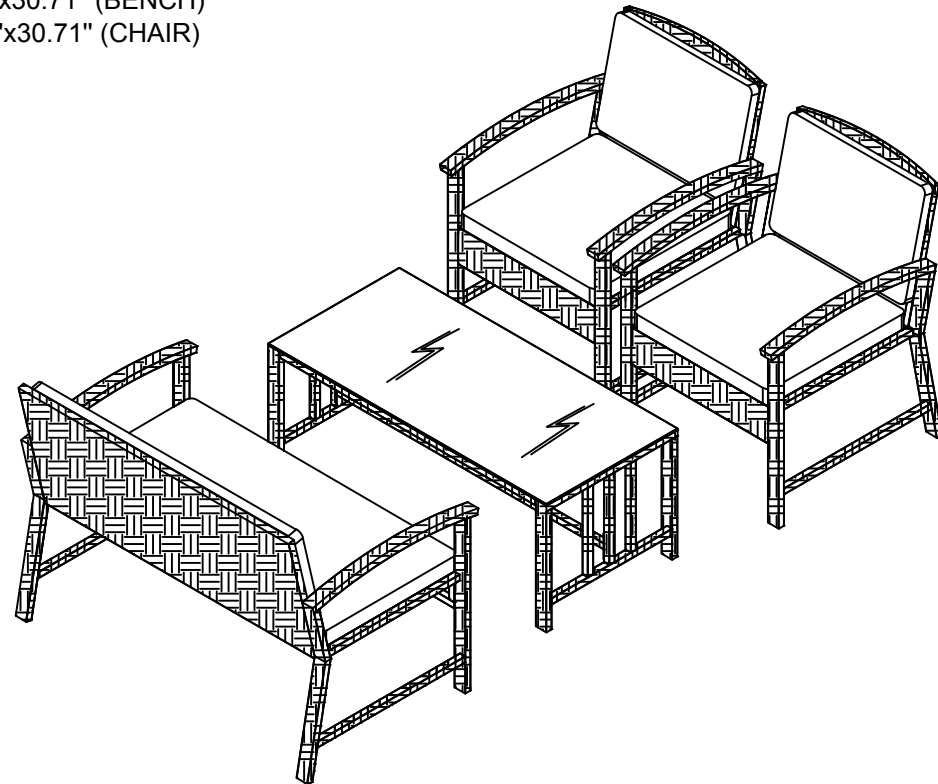

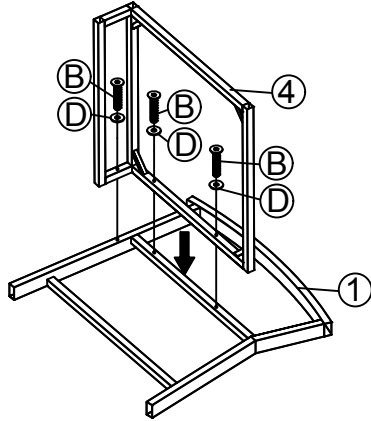
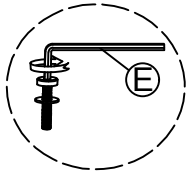

X2

STEP 1: Connect Right Frame (1) & Seat Chair (4), tighten Allen Bolt (B), Flat Washer (D) with Allen Key (E).

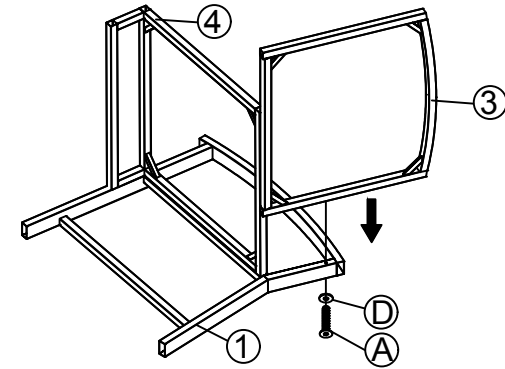
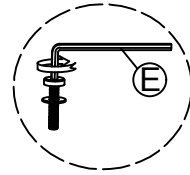

X2

STEP 2: Connect Back Chair (3) & The Part from Step (1), tighten Allen Bolt (A), Flat Washer (D) with Allen Key (E).

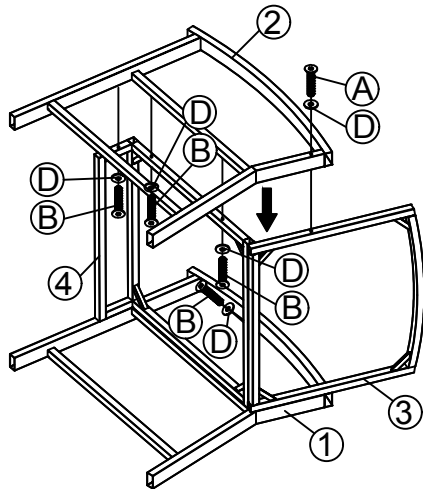
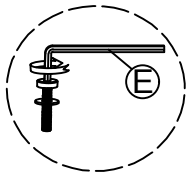

X2

STEP 3: Connect The Part from Step (2) & Left Frame (2), tighten Allen Bolt (A), Flat Washer (D) with Allen Key (E).

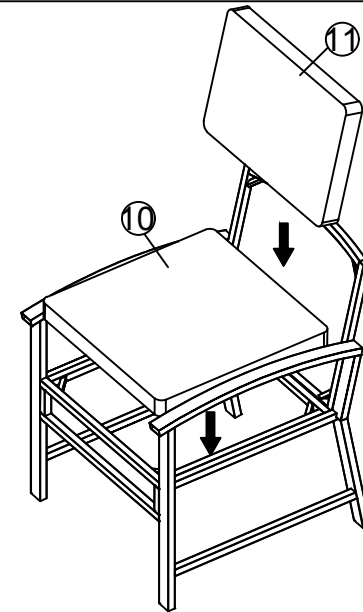

X2

STEP 4: Put Back Chair Cushion (11) and Seat Chair Cushion (10).

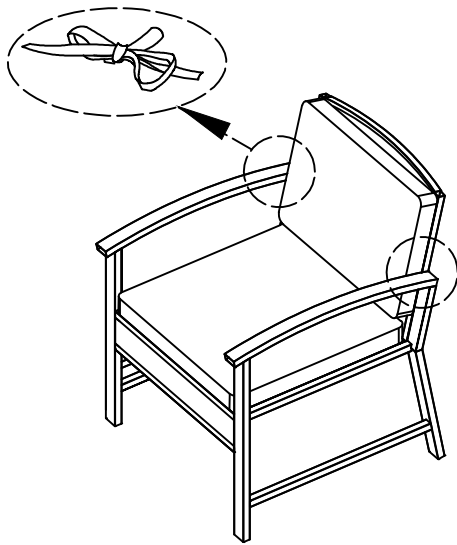

X2

STEP 5: Tie Cushion to finish Chair

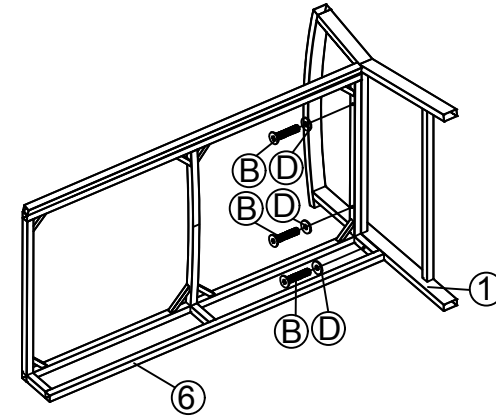
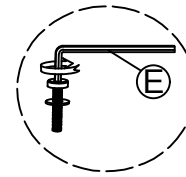

STEP 6: Connect Right Frame (1) & Seat Bench (6), tighten Allen Bolt (B), Flat Washer(D) with Allen Key (E).

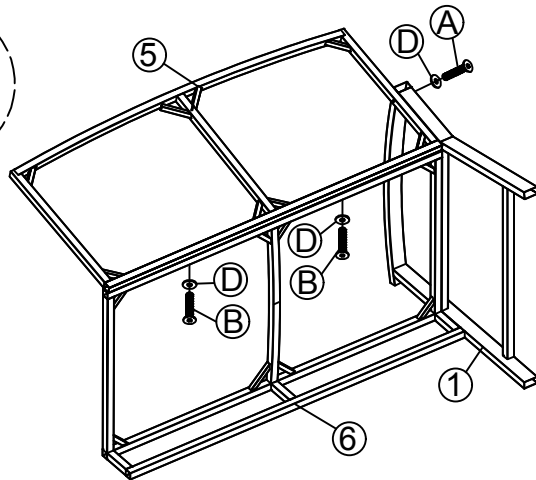
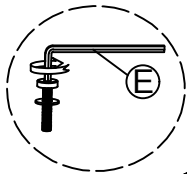

STEP 7: Connect The Part from Step (6) & Back Bench (5), tighten Allen Bolt (A), (B), Flat Washer(D) with Allen Key (E).

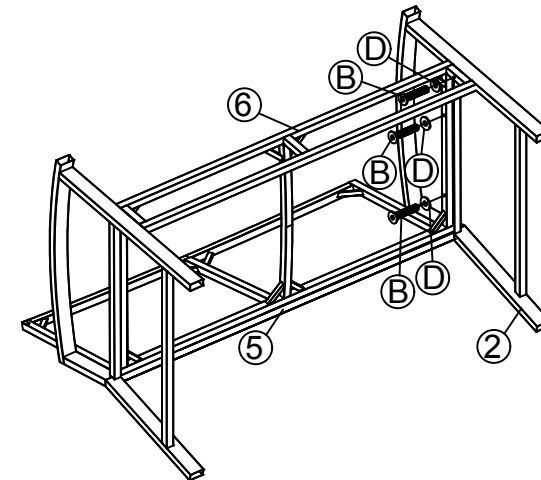
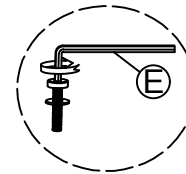

STEP 8: Connect The Part from Step (7) and Left Frame (2), tighten Allen Bolt (B), Flat Washer (D) with Allen Key (E).

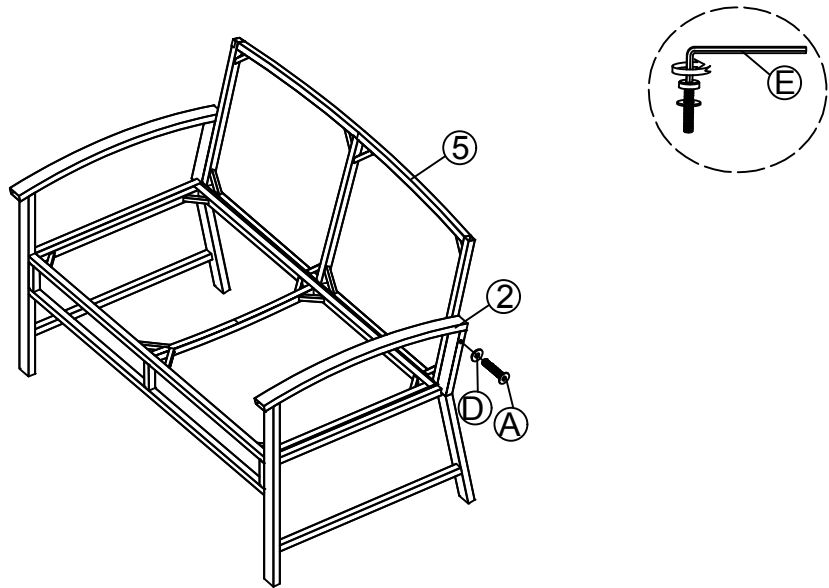

STEP 9: Connect The Part from Step (8) & Left Frame (2), tighten Allen Bolt (A), Flat Washer (D) with Allen Key (E).

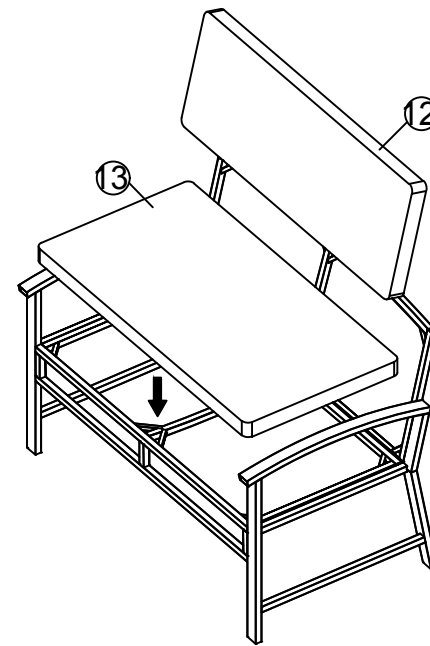

STEP 10: Put Back Bench Cushion (12) and Seat Bench Cushion (13).

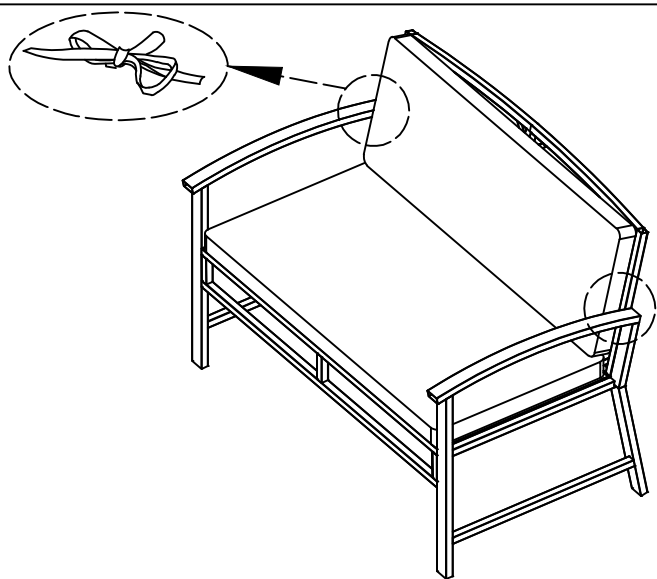

STEP 11: Tie Cushion to finish Bench

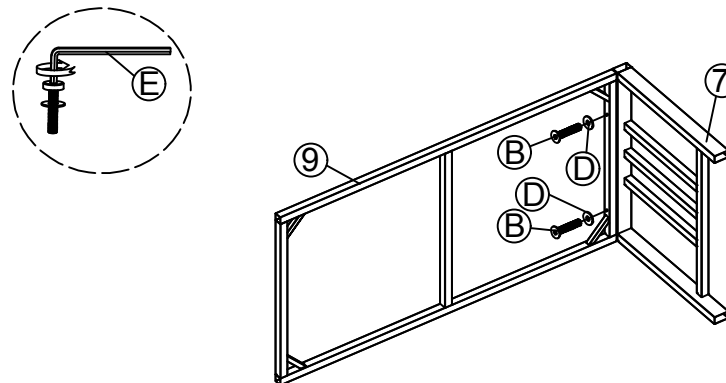

STEP 12: Connect Leg Table (7) & Top Table Frame (9), tighten Allen Bolt (B), Flat Washer (D) with Allen Key (E).

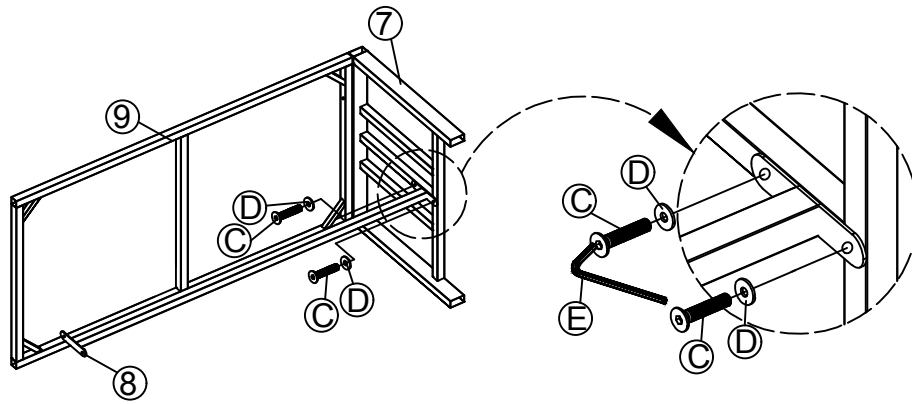

STEP 13: Connect Support Bar (8) & The Part from Step (12), tighten Allen Bolt (C), Flat Washer (D) with Allen Key (E).

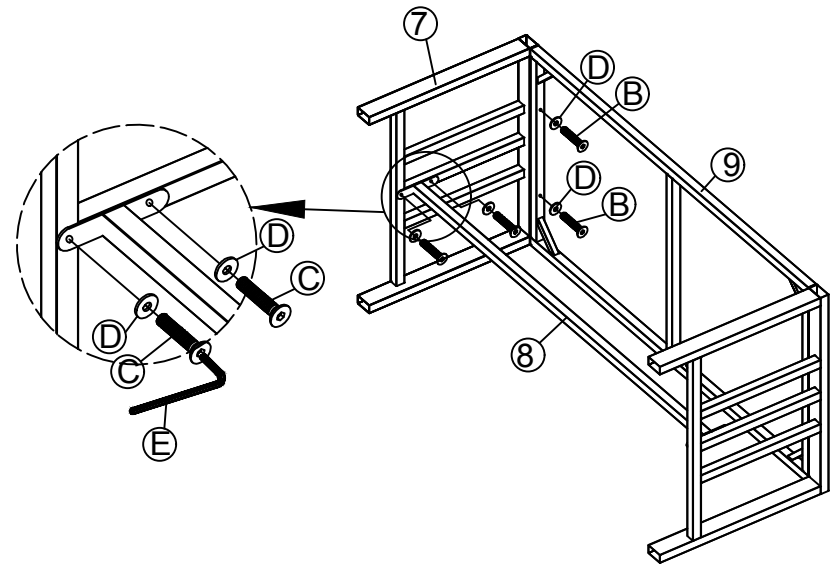

STEP 14: Connect The Part from Step (13) & Leg Table (7), tighten Allen Bolt (B)(C), Flat Washer (D) with Allen Key (E).

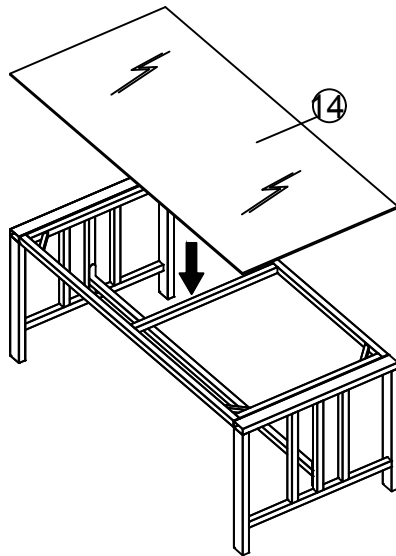

STEP 15: Put Table Glass (14) on Table to finish Table

