

Wood Platform Bed (Q)



Dear Customers,

Thank you for purchasing our product. Please read this instruction manual carefully after receiving this product. It will help you assemble this product quickly, safely and correctly. You can keep this manual for future reference.

! IMPORTANT

Please follow the instruction manuals and use a pad to protect the product during your assembly.

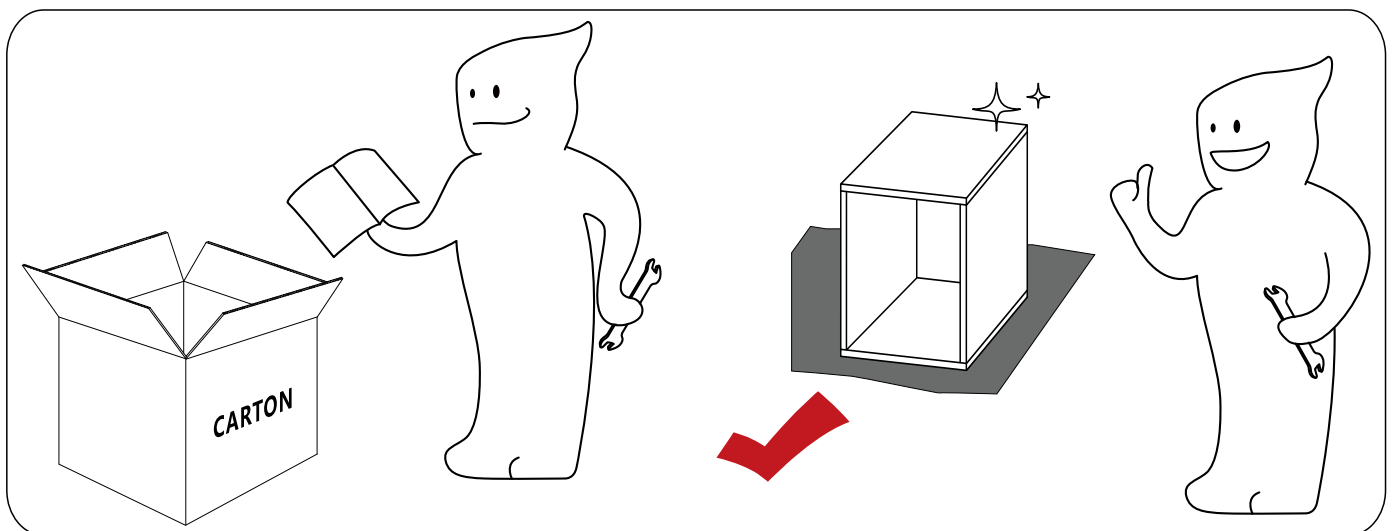
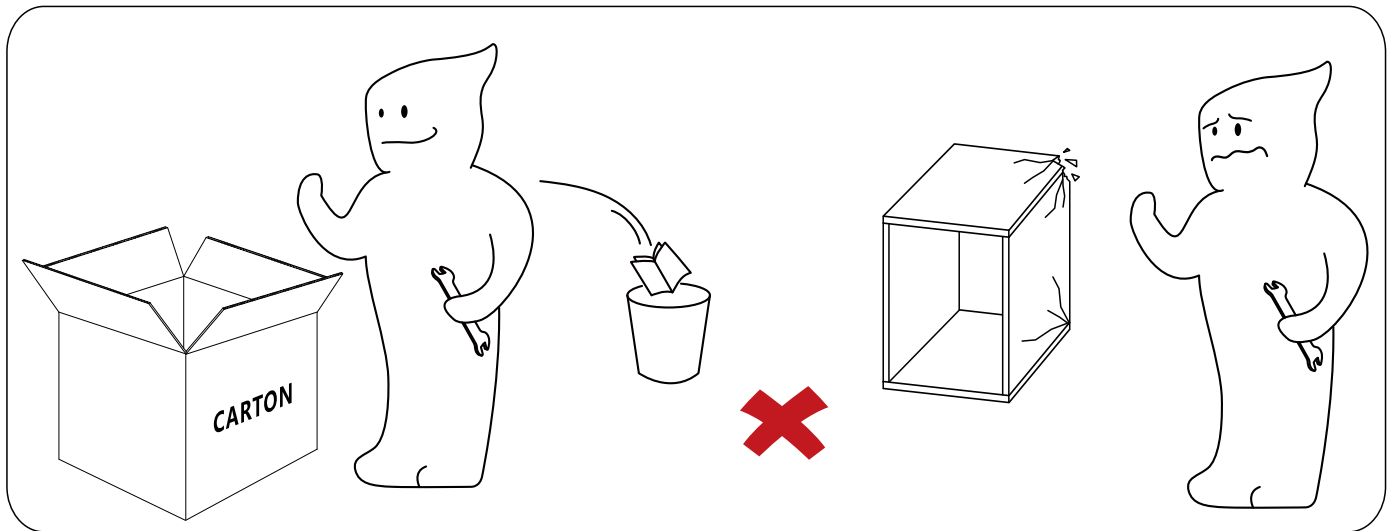











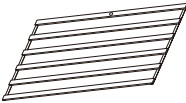

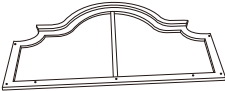

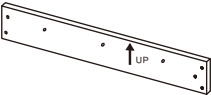
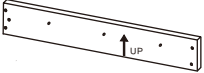

Note:

1. Should be assembled on flat ground to keep balance.
2. Before completing the installation, do not tighten the screws.
3. **Finally, tighten all the screws manually.**



For easier and better assembly, **2** or more adults are required.

ASSEMBLY INSTRUCTIONS

ALPHABETICAL NUMBERING	DESCRIBE	ILLUSTRATION	NUMBER
A	Slat		1pc
B	Slat		1pc
C	Up headboard		1pc
C1	Down headboard		1pc
C2	Connector wood		3pcs
D	Headboard leg		1pc
D1	Headboard leg		1pc
E	Footboard		1pc
F	Side panel		2pcs
F1	Side panel		2pcs
G	Support bar		1pc
H	Support bar		1pc
I	Support bar		1pc
J	Support wood		4pcs
K	Support leg		2pcs
L	Support leg		2pcs
M	Wood leg		1pc
M1	Wood leg		1pc

ASSEMBLY INSTRUCTIONS

Ruler-Use this ruler to help correctly identify the screws.

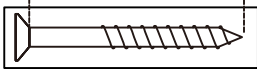

The length of the screw is measured from the rod part excluding the screw cap (30mm screw shown).

ALPHABETICAL NUMBERING	DESCRIBE	ILLUSTRATION	NUMBER
N	Connector plate 100x2 mm		4pcs
N2	Connector plate 35x2 mm		10pcs
O	Sponge-cushion		4pcs
P	Washer φ8x18x1.5 mm		48pcs+1pc
P1	Washer φ6x18x1.5 mm		16pcs
Q	Wrench M6		1pc
R	Screw M8x50 mm		1pc
R1	Screw M8x30 mm		12pcs
R2	Screw M8x35 mm		5pcs
R3	Screw M8x25 mm		8pcs
R4	Screw M8x16 mm		22pcs+1pc
R5	Screw M6x30 mm		6pcs
R6	Screw M6x16 mm		20pcs+1pc

ASSEMBLY INSTRUCTIONS

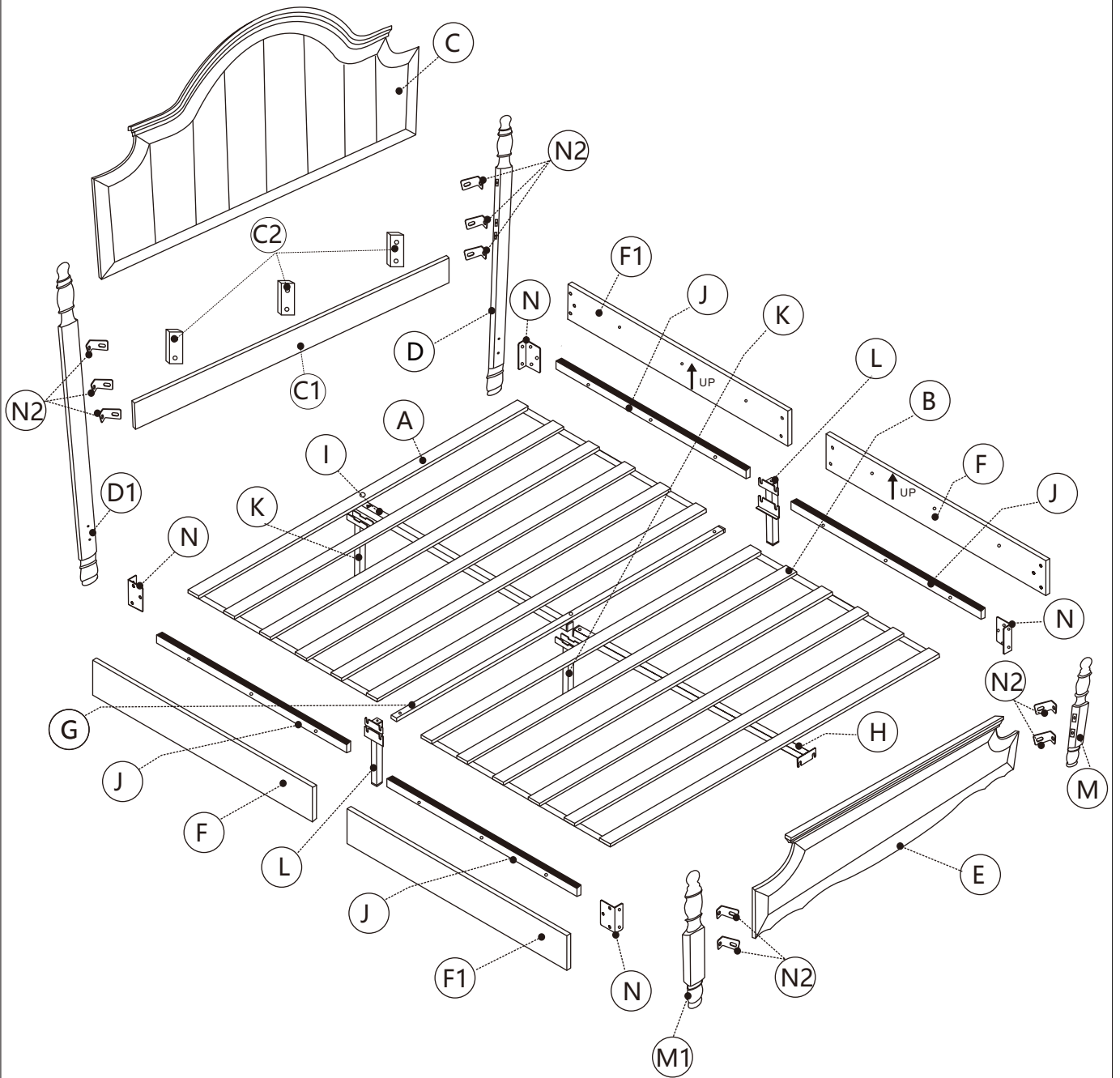

ASSEMBLY INSTRUCTIONS

1 Tight all the innerscrew after all holes are lined. When installing the connector N1, it is essential to ensure that the orientation relationship between connector N1 and the holes on the side of components M/M1/D/D1 is the same as shown in the image.

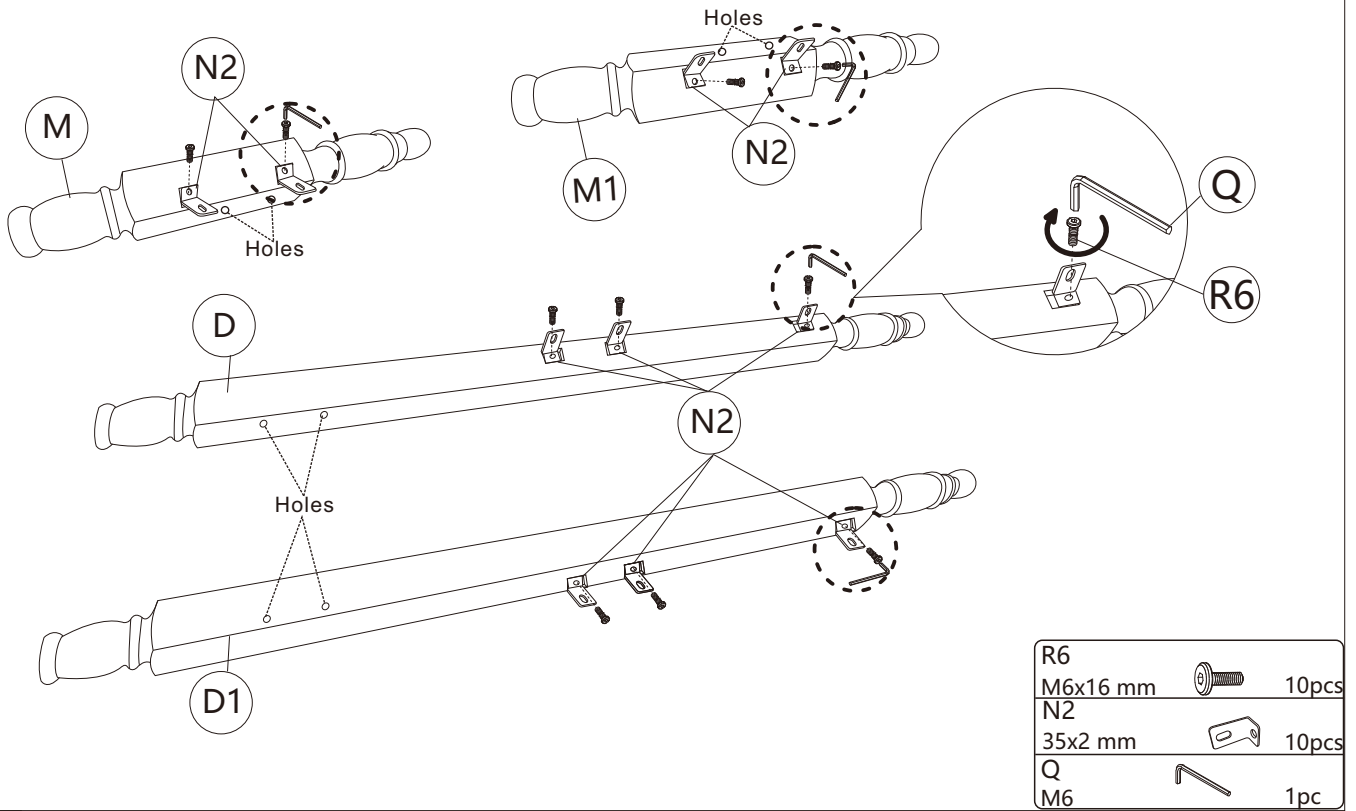



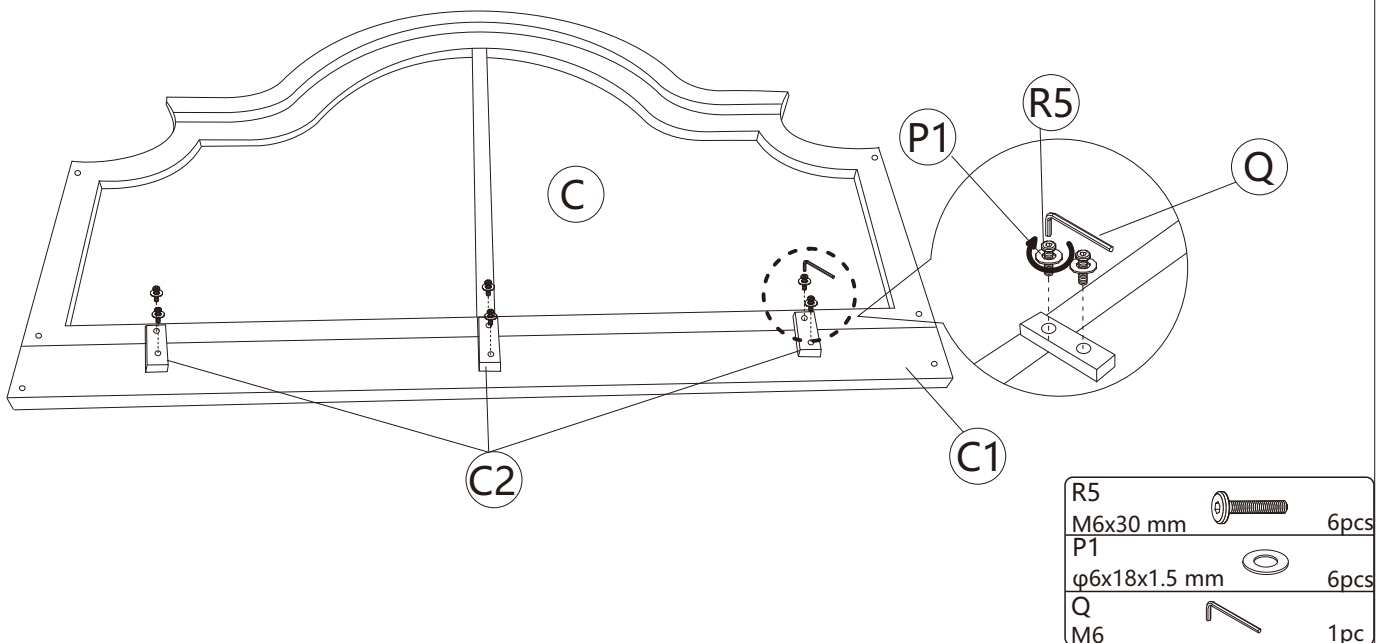

2

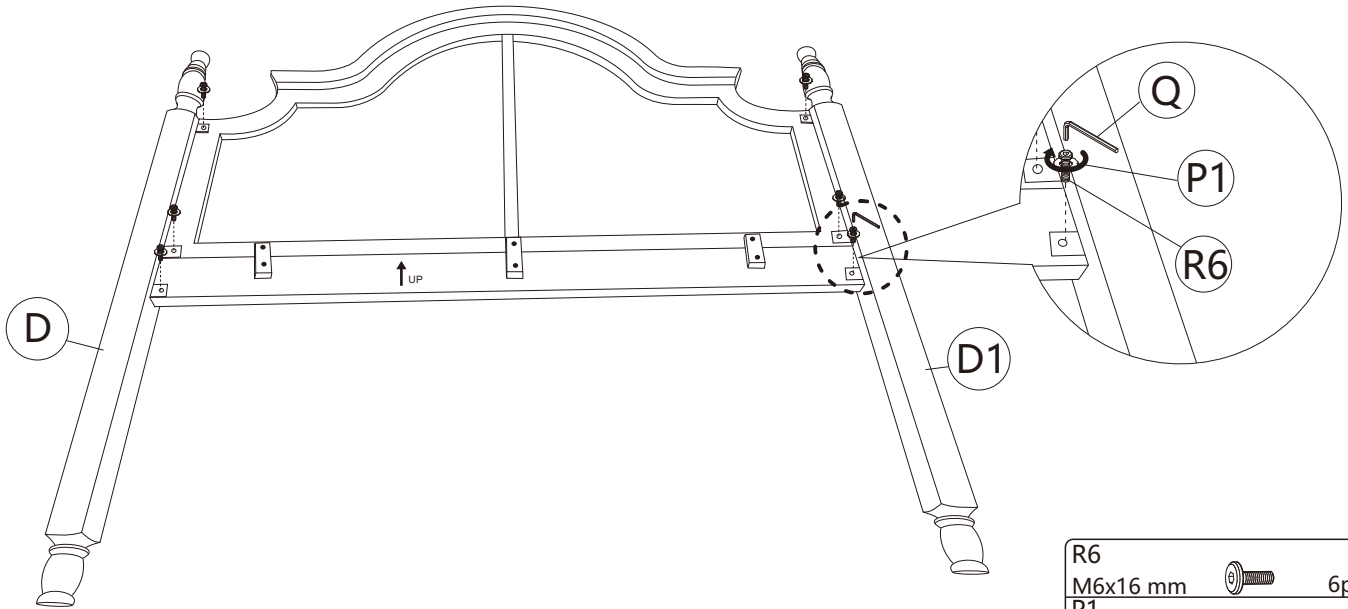

ASSEMBLY INSTRUCTIONS





3

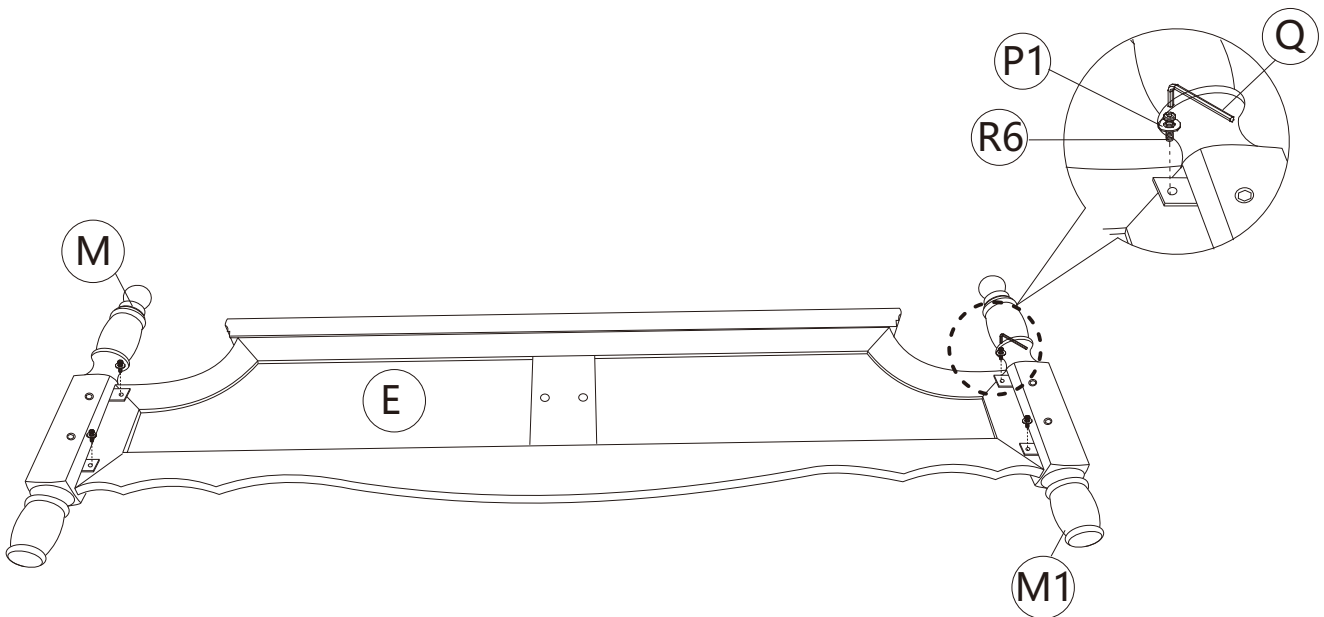

R6		6pcs
M6x16 mm		
P1		6pcs
φ6x18x1.5 mm		
Q		6pcs
M6		1pc

4



R6		4pcs
M6x16 mm		
P1		4pcs
φ6x18x1.5 mm		
Q		4pcs
M6		1pc

ASSEMBLY INSTRUCTIONS

5 Take out parts F and F1, and lock the iron frame foot L in the middle according to the figure. Note that there are **2 holes** located on the inner side of the board. Then lock the bed hanging pieces N on the front and rear of the board, with **3 holes** on each side.

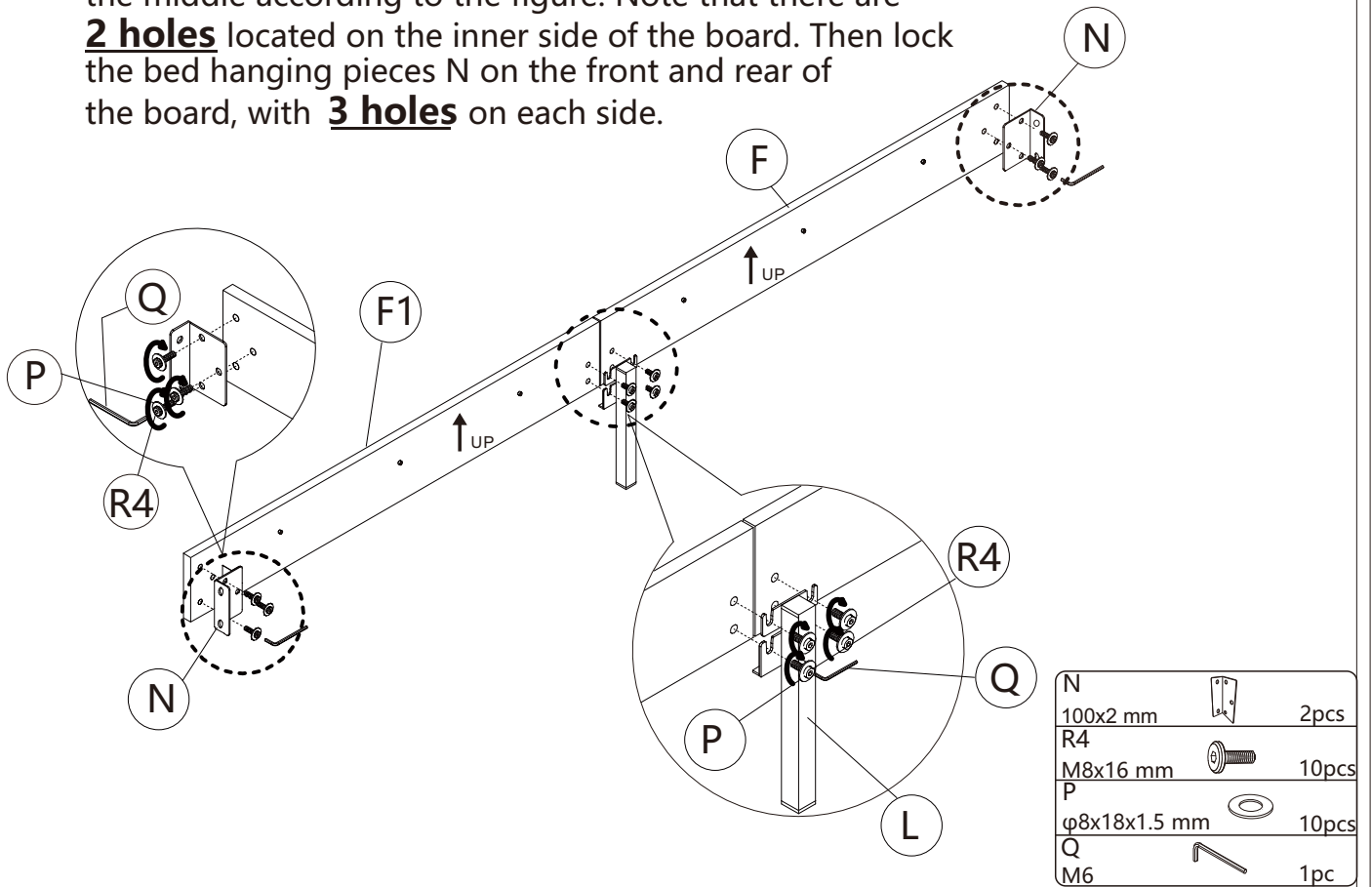



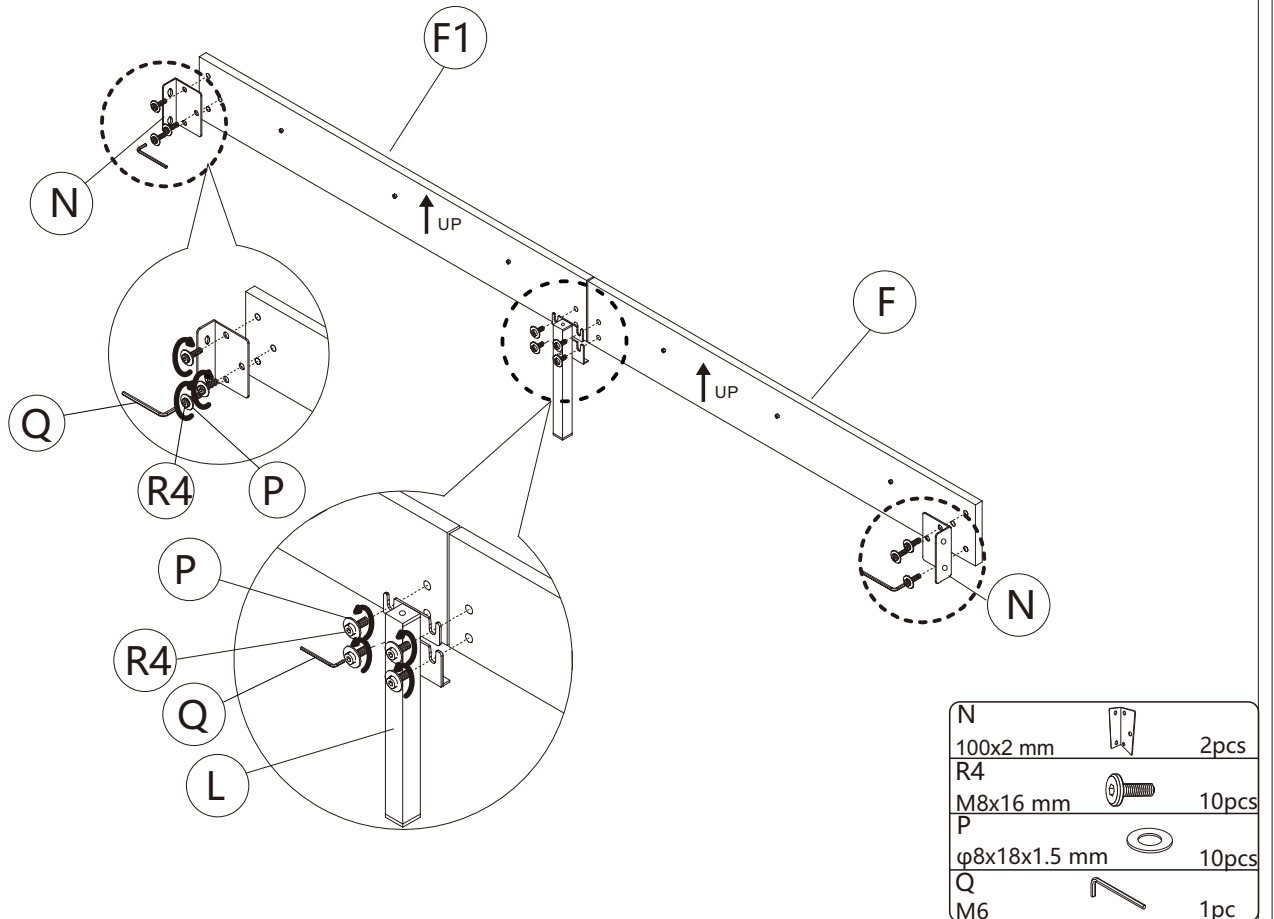

6 Same as Step 5

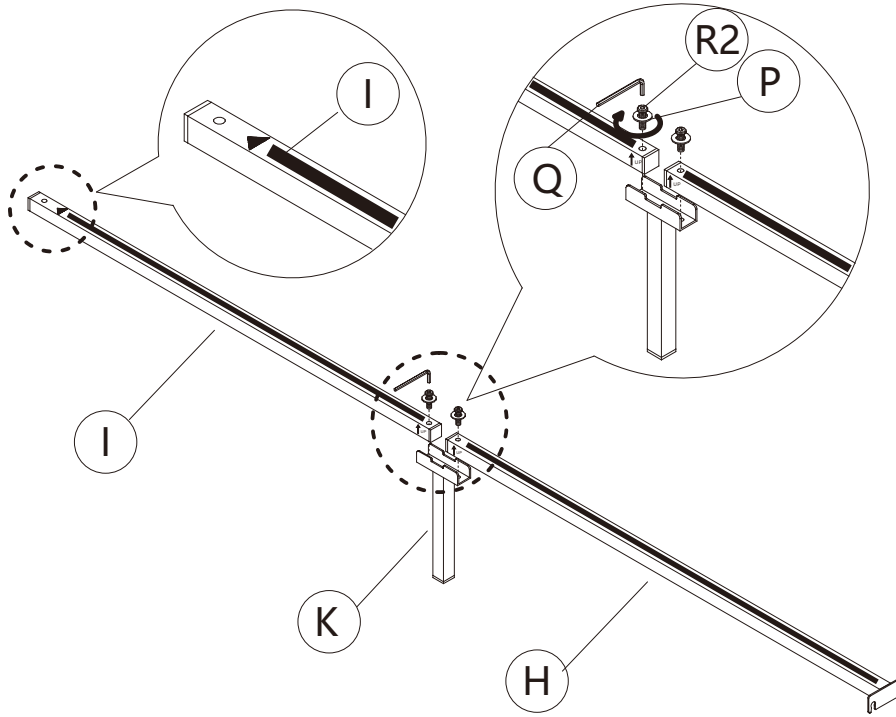

ASSEMBLY INSTRUCTIONS



7

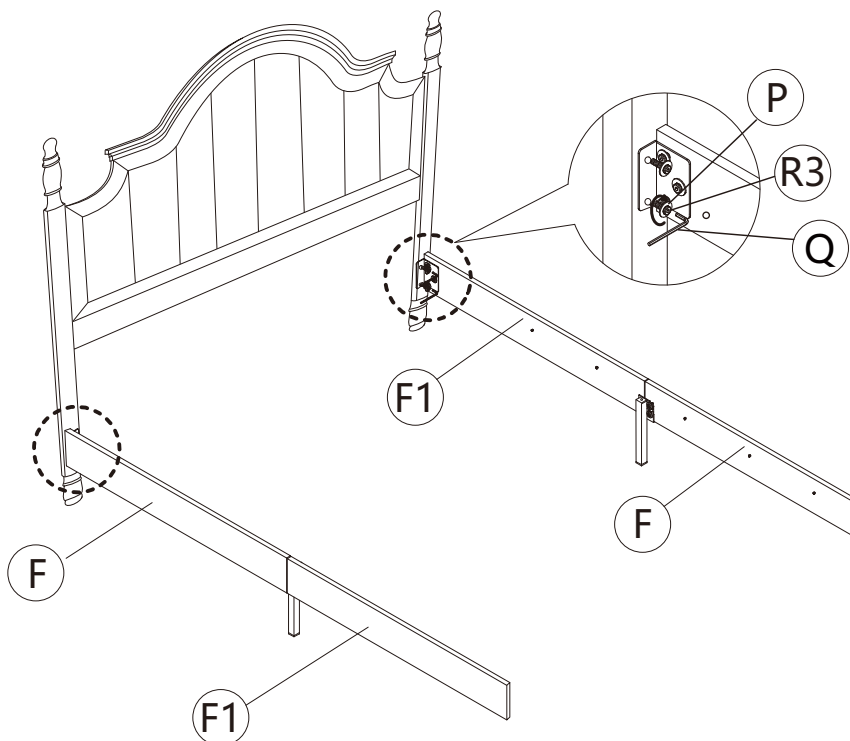

R2		2 pcs
M8x35 mm		
P		2 pcs
φ8x18x1.5 mm		
Q		1 pc
M6		

8





R3		4 pcs
M8x25 mm		
P		4 pcs
φ8x18x1.5 mm		
Q		1 pc
M6		

ASSEMBLY INSTRUCTIONS

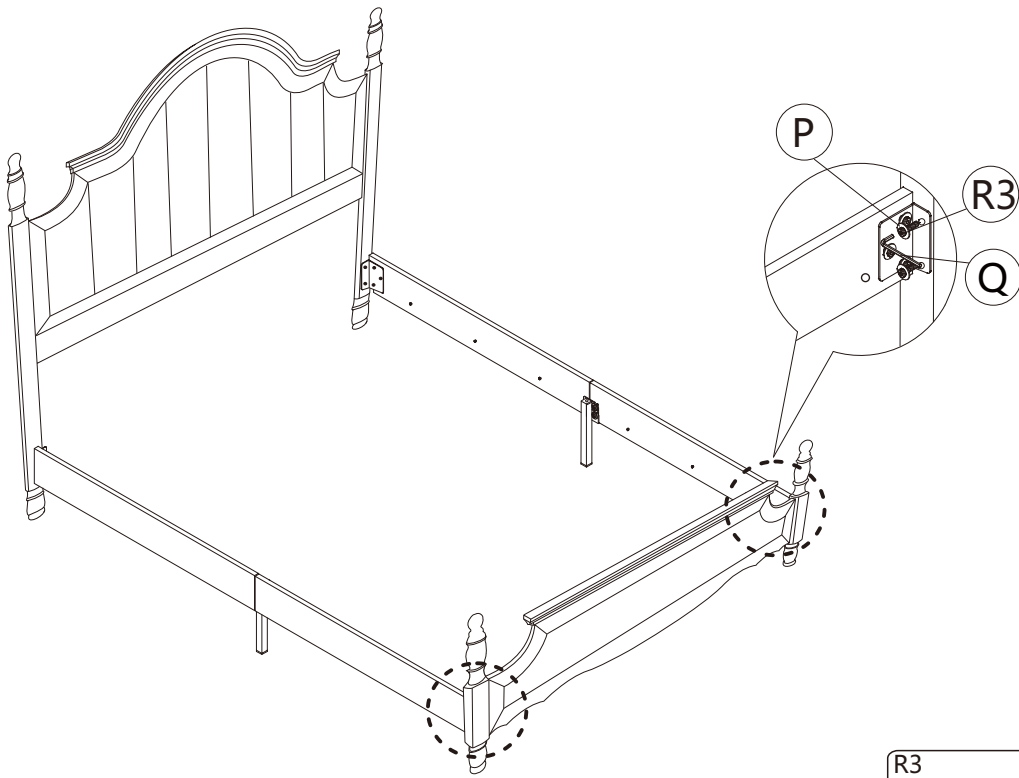

9

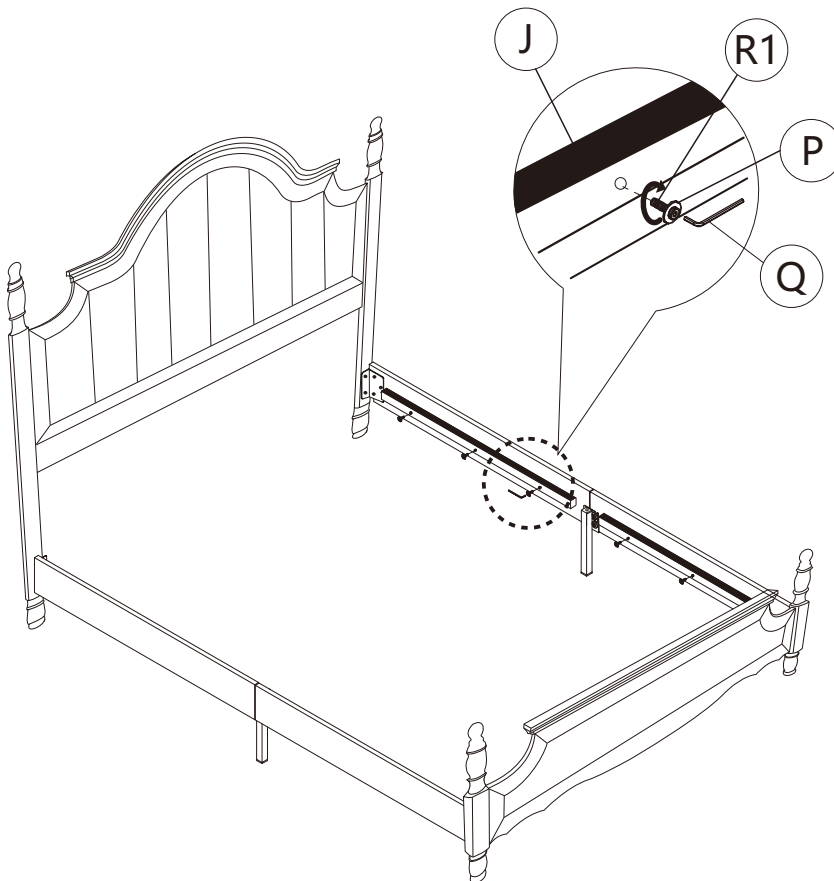

R3		4pcs
M8x25 mm		
P		4pcs
φ8x18x1.5 mm		
Q		1pc
M6		

10





R1		12pcs
M8x30 mm		
P		12pcs
φ8x18x1.5 mm		
Q		1pc
M6		

ASSEMBLY INSTRUCTIONS

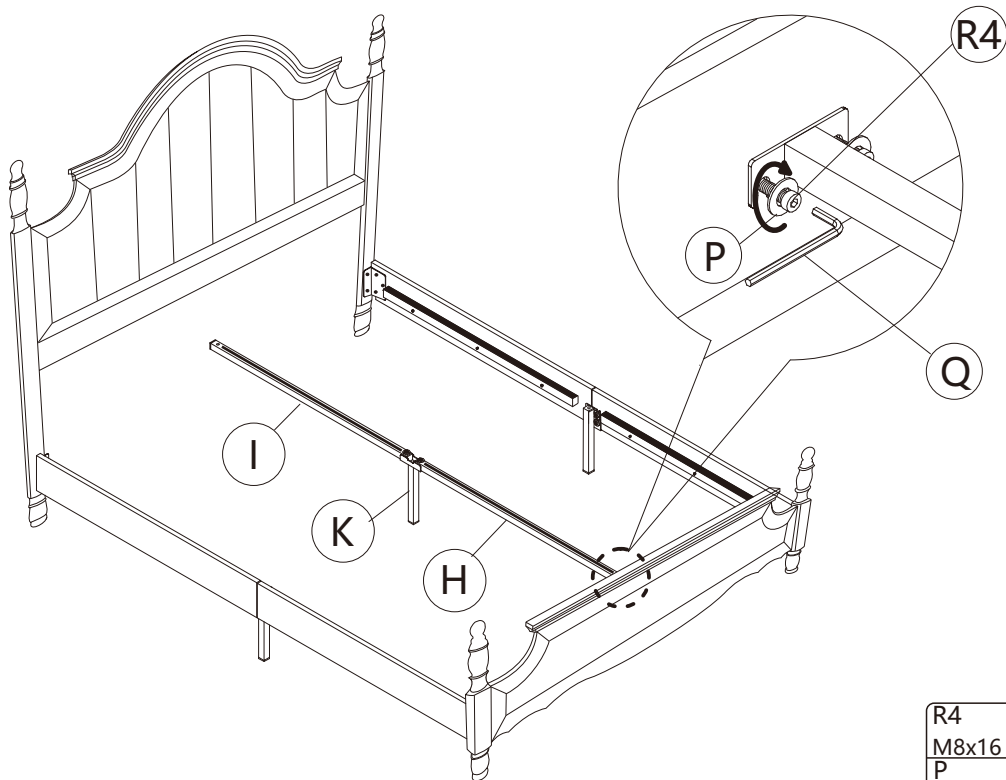

11

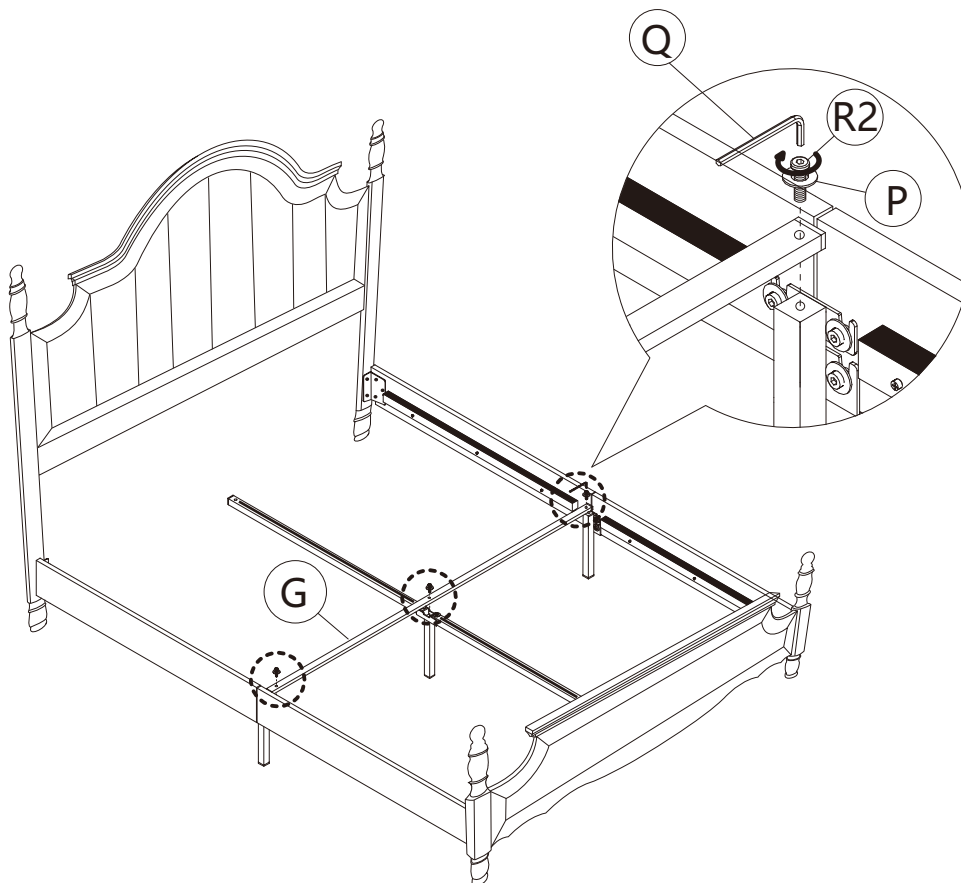

R4		2 pcs
M8x16 mm		
P		2 pcs
φ8x18x1.5 mm		
Q		1 pc
M6		

12





R2		3 pcs
M8x35 mm		
P		3 pcs
φ8x18x1.5 mm		
Q		1 pc
M6		

ASSEMBLY INSTRUCTIONS

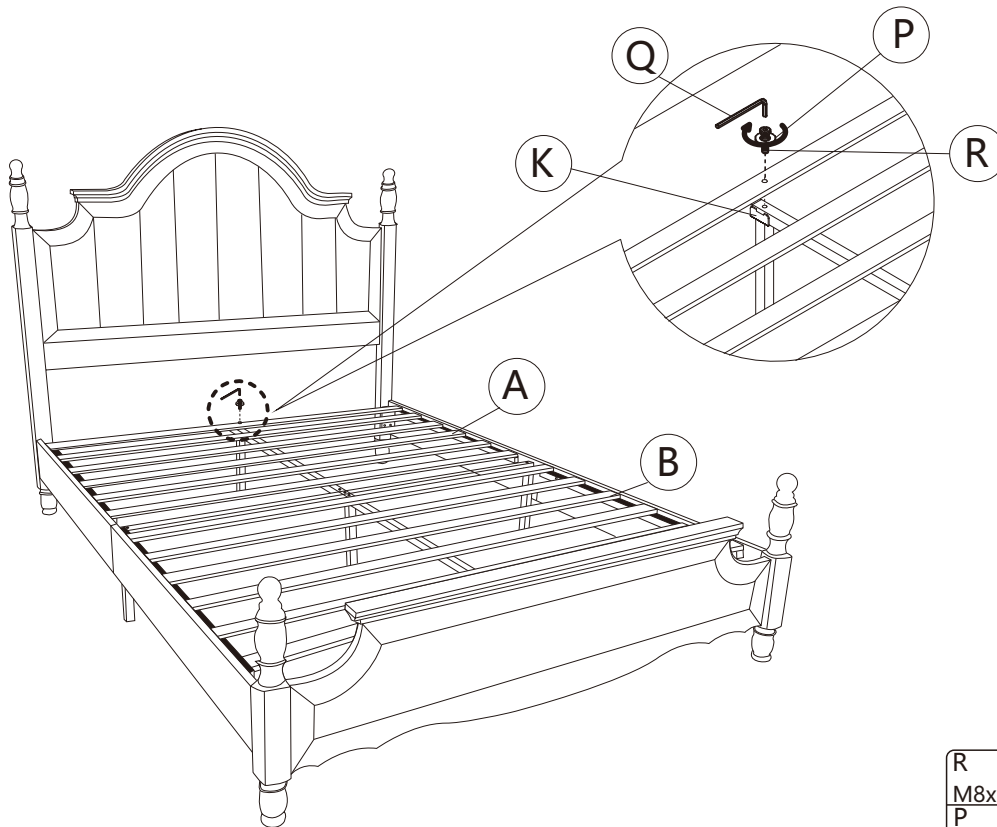
13 Note that there is a slat with a hole in part A for connecting to part K.



Pls make sure that all screws are 100% tight.

R		1pc
M8x50 mm		
P		1pc
φ8x18x1.5 mm		
Q		1pc
M6		

14 Stick **O** on the back to avoid noise.

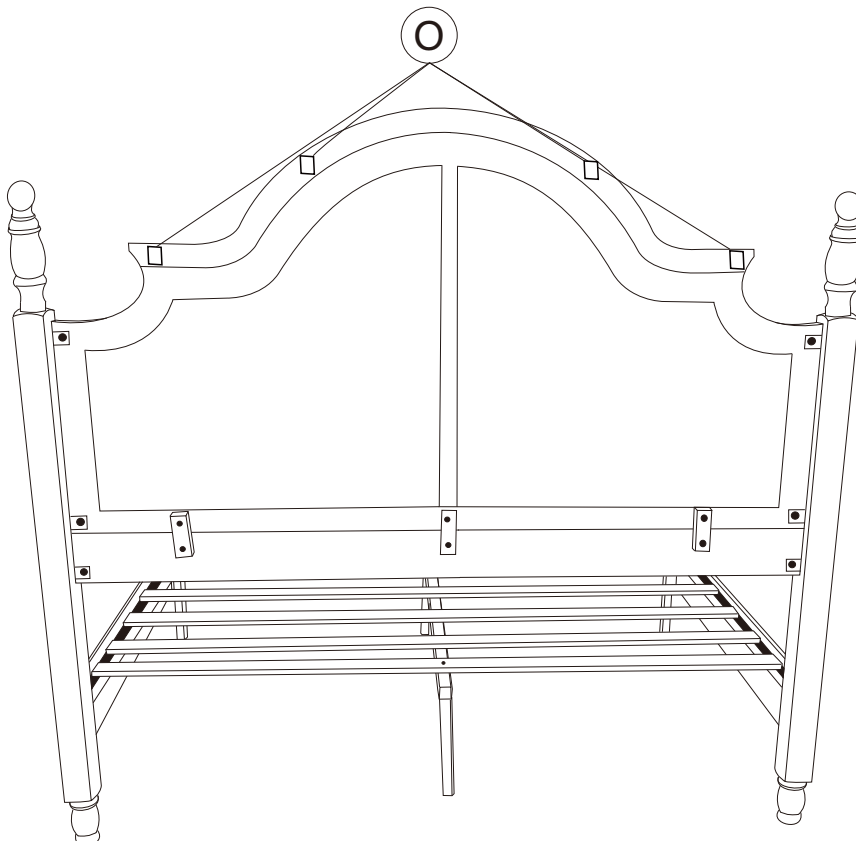

15



Installation Complete