

ASSEMBLY INSTRUCTIONS



ASSEMBLY INSTRUCTIONS

ASSEMBLY TIPS:

1. Remove hardware from box and sort by size.
2. Please check to see that all hardware and parts are present prior to start of assembly.
3. Please follow attached instructions in the same sequence as numbered to assure fast & easy assembly.



WARNING!

1. Don't attempt to repair or modify parts that are broken or defective. Please contact the store immediately.
2. This product is for home use only and not intended for commercial establishments.



ASSEMBLY TIME





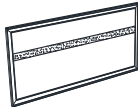
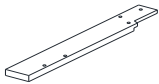
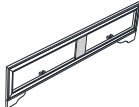
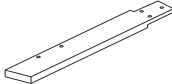

20 MINUTES

PARTS IDENTIFICATION

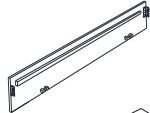

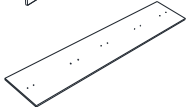
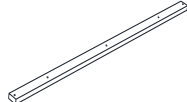
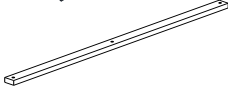
B1 (BOX 1)

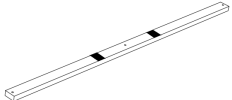
A	HEADBOARD PANEL		1PC	C	RIGHT HEADBOARD LEG		1PC
B	FOOTBOARD		1PC	D	LEFT HEADBOARD LEG		1PC

B2 (BOX 2)

E	BED RAIL		2PCS	H	BED SLAT SUPPORT WITH LEVELER		5PCS
F	CONCEAL PANEL		4PCS	I	DRAWER BOTTOM TRESTLE BAR		1PC
G	BED SLAT		3PCS	J	DRAWER SUPPORT RAIL		2PCS
G2	BED SLAT WITH STOPPER		2PCS	K	DRAWER SUPPORT LEG WITH LEVELER		1PC

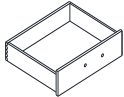
B3 (BOX 3)

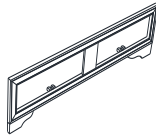
L	DRAWER BOX		2PCS	HB	205111F(B1) FROM BOX 1 HEADBOARD COMPLETE		1PC	B	205111F(B1) FROM BOX 1 FOOTBOARD		1PC
---	------------	---	------	----	--	---	-----	---	--	---	-----

ASSEMBLY INSTRUCTIONS

ASSEMBLY TIPS:

1. Remove hardware from box and sort by size.
2. Please check to see that all hardware and parts are present prior to start of assembly.
3. Please follow attached instructions in the same sequence as numbered to assure fast & easy assembly.







WARNING!









1. Don't attempt to repair or modify parts that are broken or defective. Please contact the store immediately.
2. This product is for home use only and not intended for commercial establishments.

HARDWARE IDENTIFICATION

Z-B1 (BOX 1) - HARDWARE PACK IS LOCATED IN 205111F (B1)

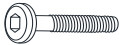
1	BOLT (M6 x 30mm - BLK)		6PCS	3	FLAT WASHER (1/4" ID x 13mm - BLK)		6PCS
2	LOCK WASHER (1/4" - BLK)		6PCS	4	ALLEN WRENCH (M4 x 60mm - BLK)		1PC

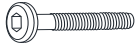
Z-B2 (BOX 2) - HARDWARE PACK IS LOCATED IN 205111F (B2)

5	FLAT HEAD SCREW (M4 x 32mm - RBW)		14PCS	9	LOCK WASHER (1/4" - BLK)		2PCS
6	PAN HEAD SCREW (M3.5 x 20mm - BLK)		20PCS	10	FLAT WASHER (1/4" ID x 13mm - BLK)		2PCS
7	SHORT BOLT (M6 x 35mm - BLK)		2PCS	11	SMALL ALLEN WRENCH (M4 x 60mm - BLK)		1PC
8	LONG BOLT (M6 x 50mm - BLK)		6PCS	12	BIG ALLEN WRENCH (M5 x 65mm - BLK)		1PC

NOTE:

Phillips head screw driver is required in the assembly process; however, manufacturer does not provide this item.

ASSEMBLY INSTRUCTIONS

STEP 1

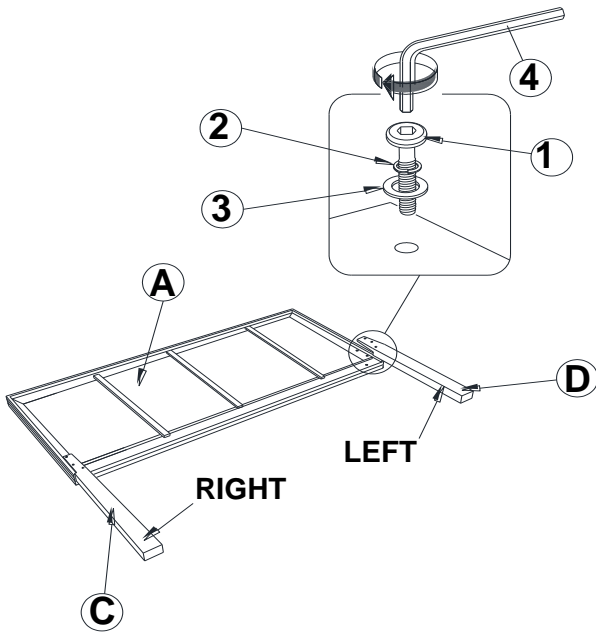

****BACK VIEW****

Note : Please take note of the marking sticker (L&R) on the leg.

STEP 2

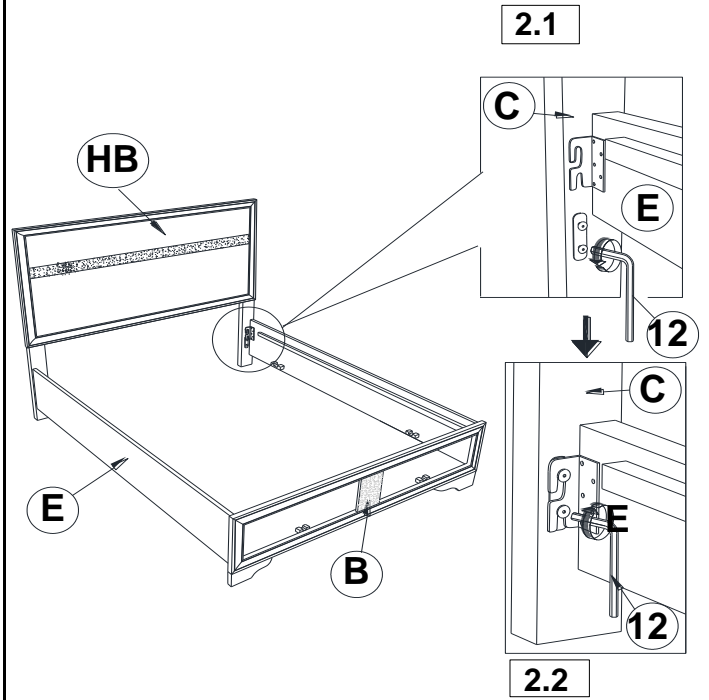

STEP 3

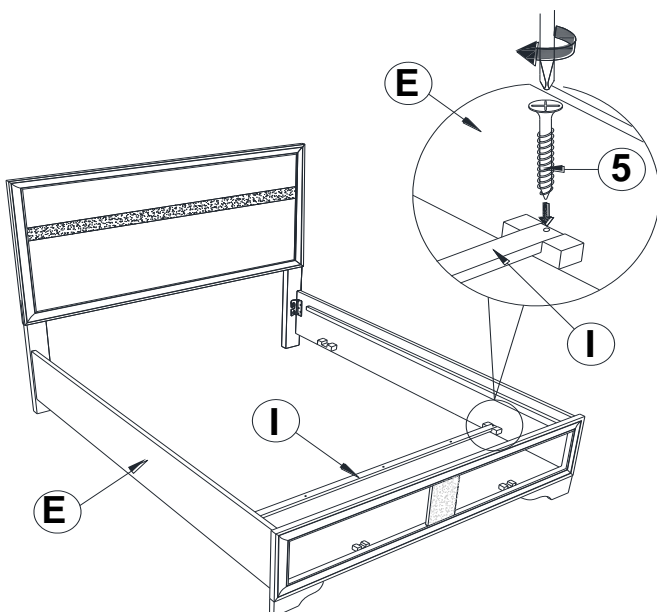

STEP 4

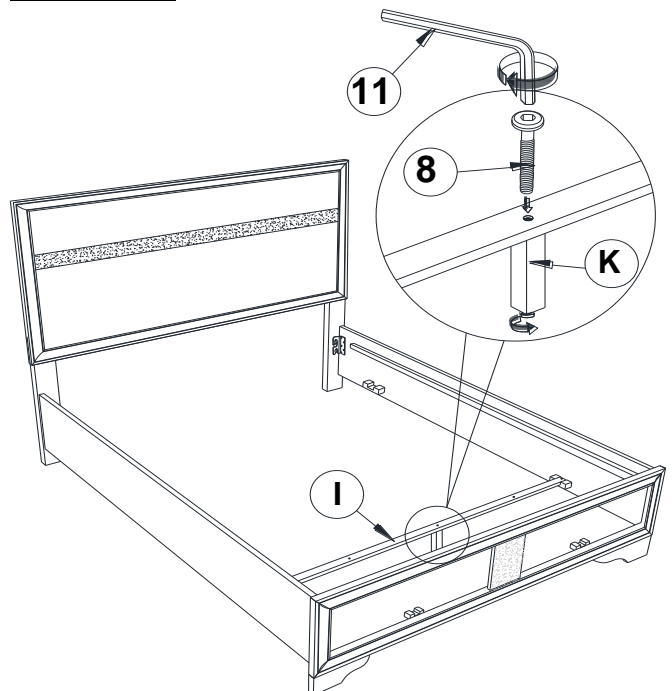

ASSEMBLY INSTRUCTIONS

STEP 5

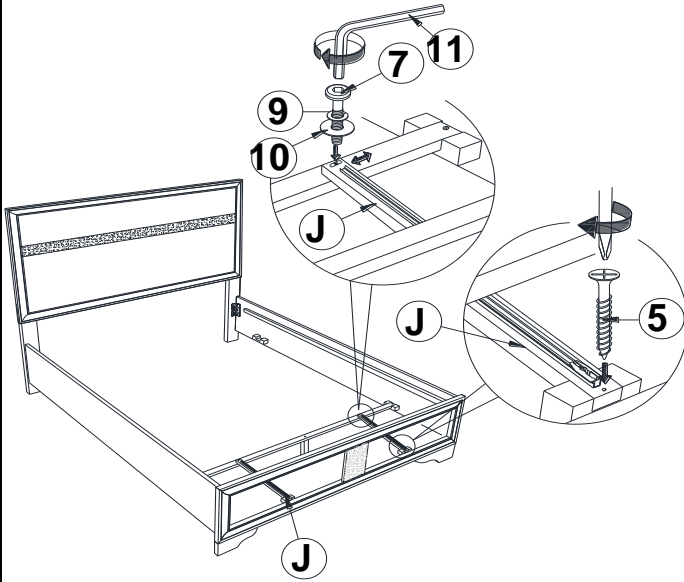

STEP 6

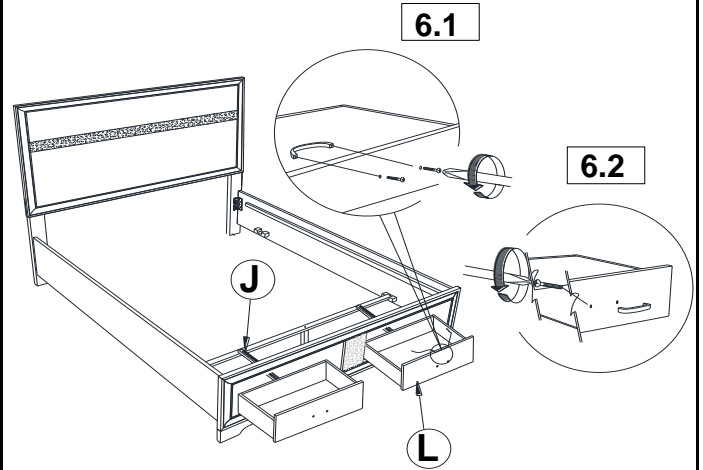

STEP 7

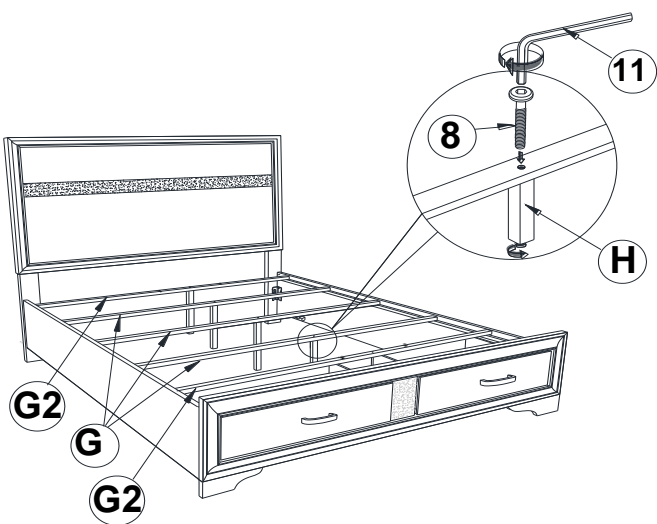

STEP 8

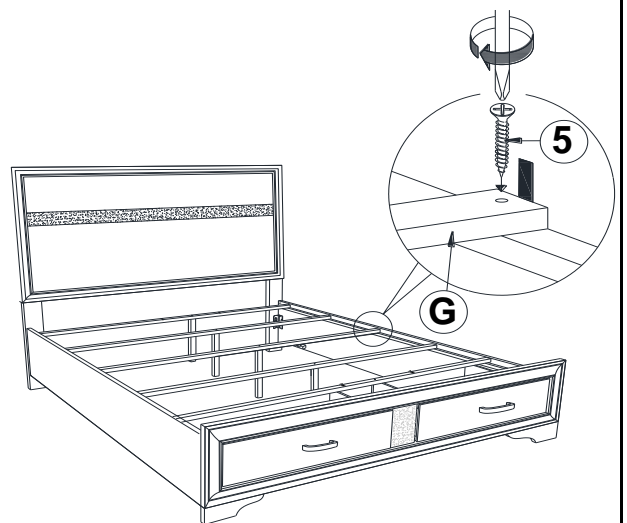

ASSEMBLY INSTRUCTIONS

STEP 9

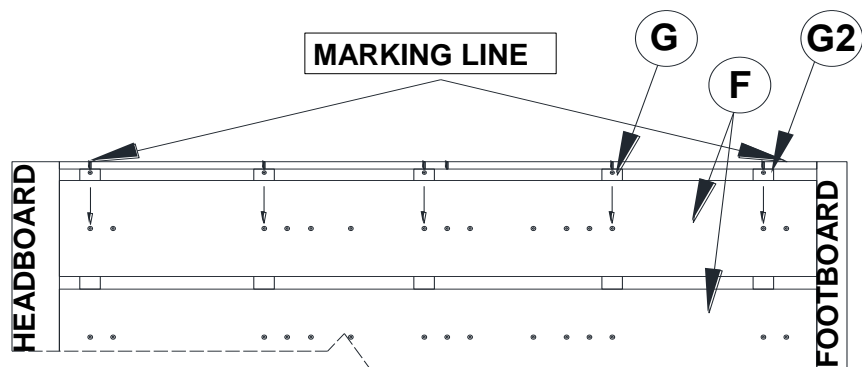

TIGHTEN THE PANHEAD SCREW (6) BY FOLLOW THE ARROW AS SHOWN

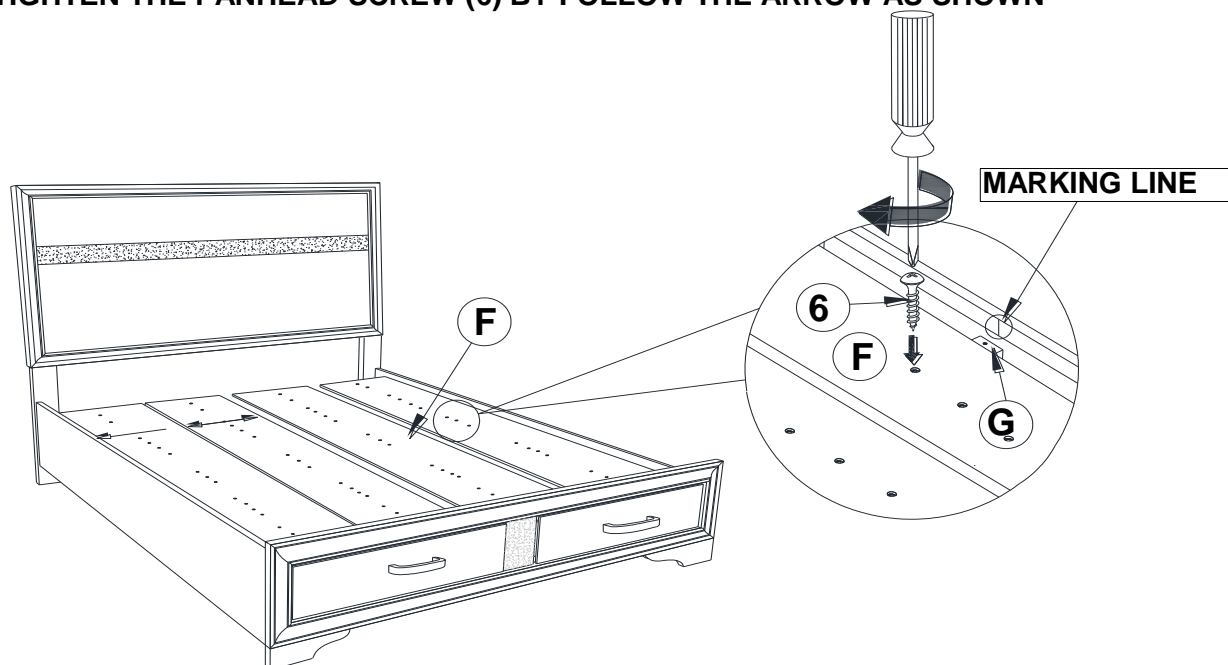

STEP 10

COMPLETE

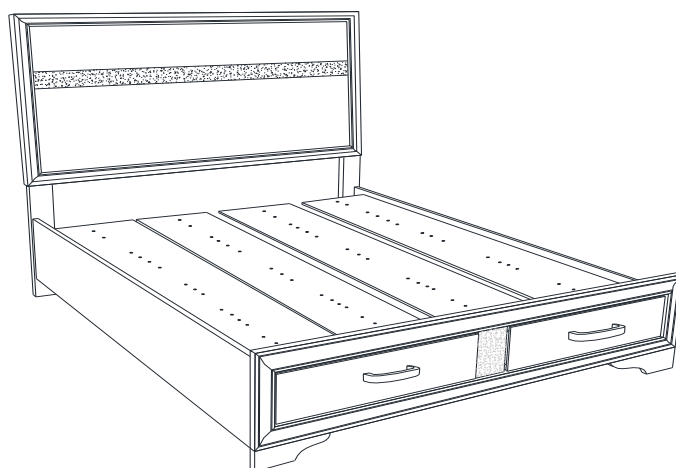

Inner Size: 54.75"W X 76.00"D

Inner Size of Drawer: 23.25"W X 15.00"D X 4.00"H X 0.25"T

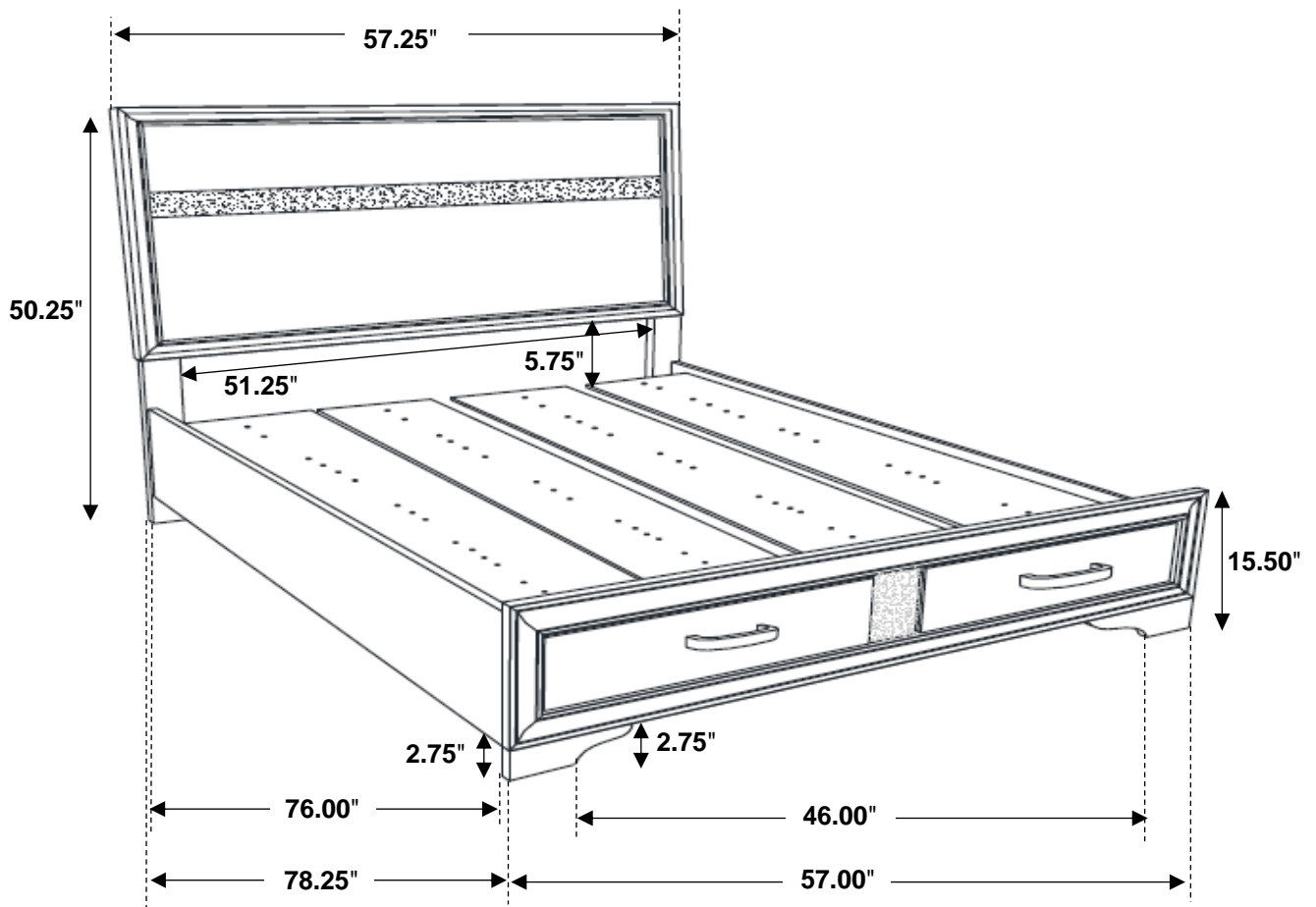

Note: Dimension tolerance $\pm 5\%$

ASSEMBLY INSTRUCTIONS



ASSEMBLY INSTRUCTIONS

ASSEMBLY TIPS:

1. Remove hardware from box and sort by size.
2. Please check to see that all hardware and parts are present prior to start of assembly.
3. Please follow attached instructions in the same sequence as numbered to assure fast & easy assembly.



WARNING!

1. Don't attempt to repair or modify parts that are broken or defective. Please contact the store immediately.
2. This product is for home use only and not intended for commercial establishments.



ASSEMBLY TIME

5 MINUTES

PARTS IDENTIFICATION

A NIGHTSTAND

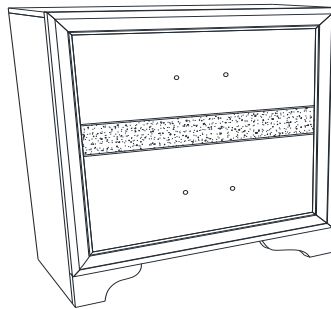

1PC

NOTE:

Phillips head screw driver is required in the assembly process; however, manufacturer does not provide this item.

STEP 1

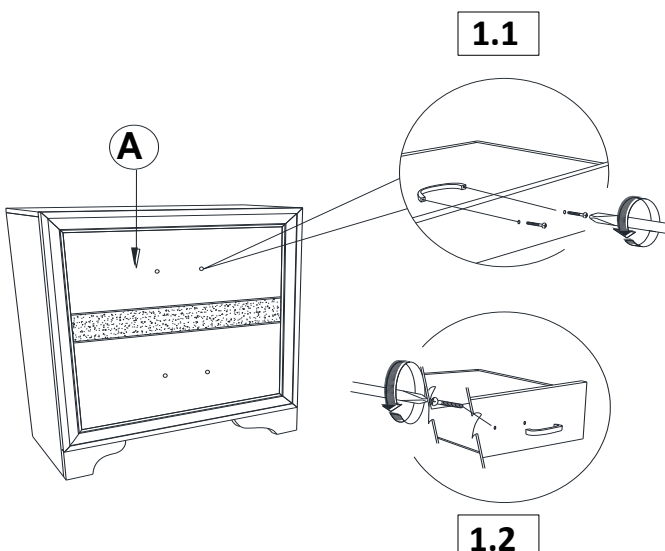

STEP 2 COMPLETE

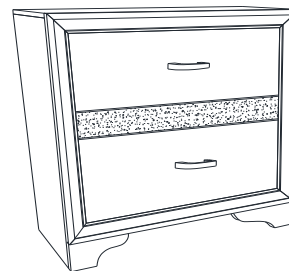

ASSEMBLY INSTRUCTIONS



205113
Dresser

REVISION 0 : 08/08/2016
REVISION 1 : 07/24/2017
REVISION 2 : 09/04/2018
REVISION 3 : 10/25/2019

PAGE 1 OF 2

COASTERFURNITURE.COM

ASSEMBLY INSTRUCTIONS

ASSEMBLY TIPS:

1. Remove hardware from box and sort by size.
2. Please check to see that all hardware and parts are present prior to start of assembly.
3. Please follow attached instructions in the same sequence as numbered to assure fast & easy assembly.



WARNING!

1. Don't attempt to repair or modify parts that are broken or defective. Please contact the store immediately.
2. This product is for home use only and not intended for commercial establishments.



ASSEMBLY TIME

5 MINUTES

PARTS IDENTIFICATION

A DRESSER

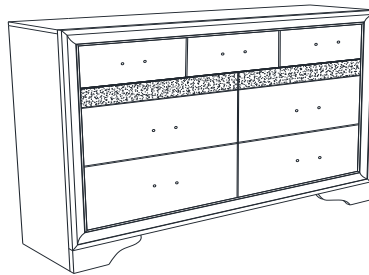

1PC

NOTE:

Phillips head screw driver is required in the assembly process; however, manufacturer does not provide this item.

STEP 1

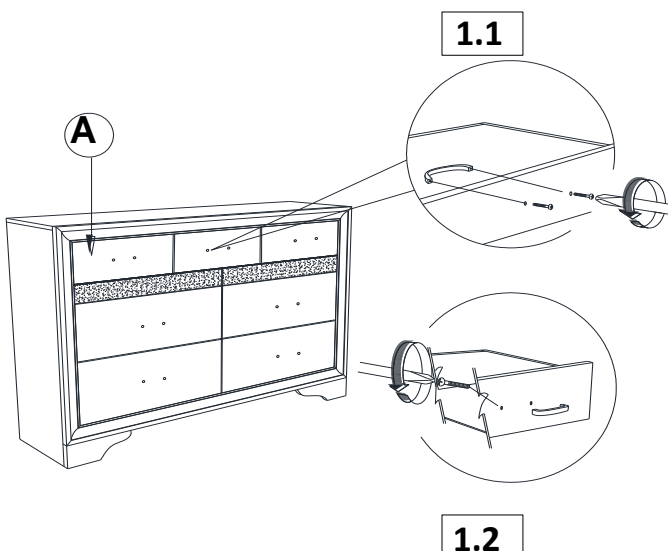

STEP 2 COMPLETE



Inner Size of Drawer A: 17.00"W X 12.50"D X 5.00"H X 0.25"T

Inner Size of Drawer B: 26.00"W X 12.50"D X 1.25"H X 0.25"T

Inner Size of Drawer C: 26.75" W X 12.50"D X 6.00"H X 0.25"T

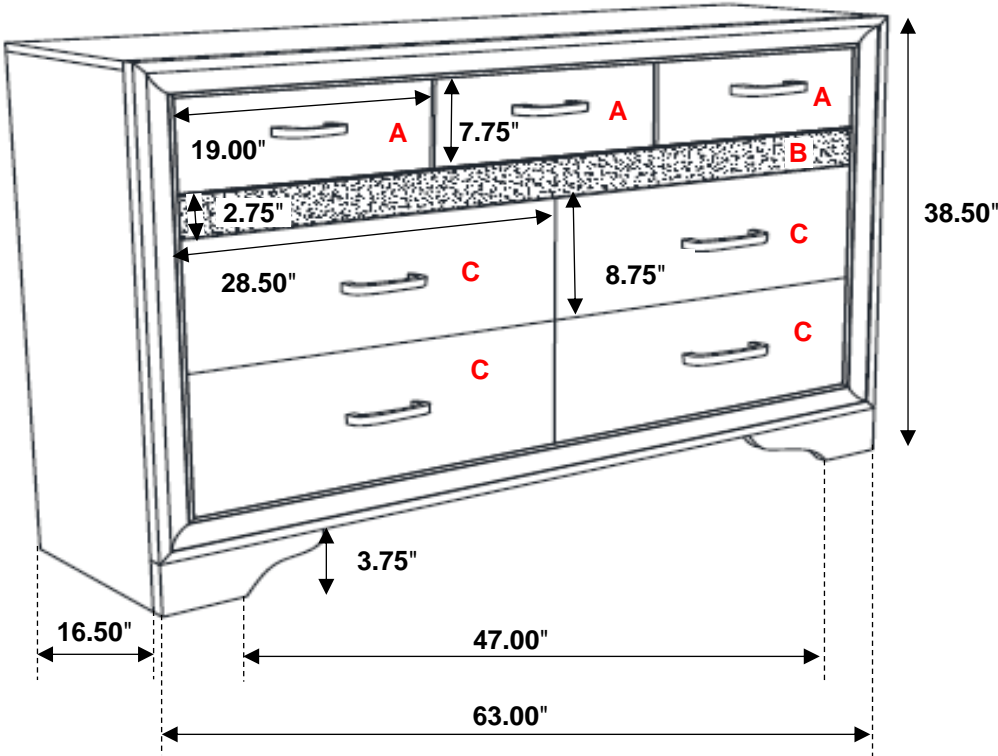

Note: Dimension tolerance $\pm 5\%$

ASSEMBLY INSTRUCTIONS



ASSEMBLY INSTRUCTIONS

ASSEMBLY TIPS:

1. Remove hardware from box and sort by size.
2. Please check to see that all hardware and parts are present prior to start of assembly.
3. Please follow attached instructions in the same sequence as numbered to assure fast & easy assembly.



WARNING!

1. Don't attempt to repair or modify parts that are broken or defective. Please contact the store immediately.
2. This product is for home use only and not intended for commercial establishments.



ASSEMBLY TIME

10 MINUTES

PARTS IDENTIFICATION

A MIRROR

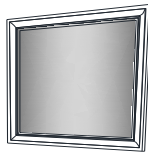

1PC

C MIRROR SUPPORT
(PACKED WITH MIRROR)

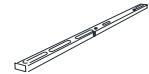

2PCS

B DRESSER
FROM BOX ITEM
#205113



1PC

HARDWARE IDENTIFICATION

1 SHORT BOLT
(M6 x 35mm - BLK)



4PCS

4 FLAT WASHER
(1/4" ID x 19mm - BLK)



8PCS

2 LONG BOLT
(M6 x 40mm - BLK)



4PCS

5 ALLEN WRENCH
(M4 x 60MM - BLK)



1PC

3 LOCK WASHER
(1/4" - BLK)



8PCS

ASSEMBLY INSTRUCTIONS

STEP 1

ARROW MARKING FACE UPWARD

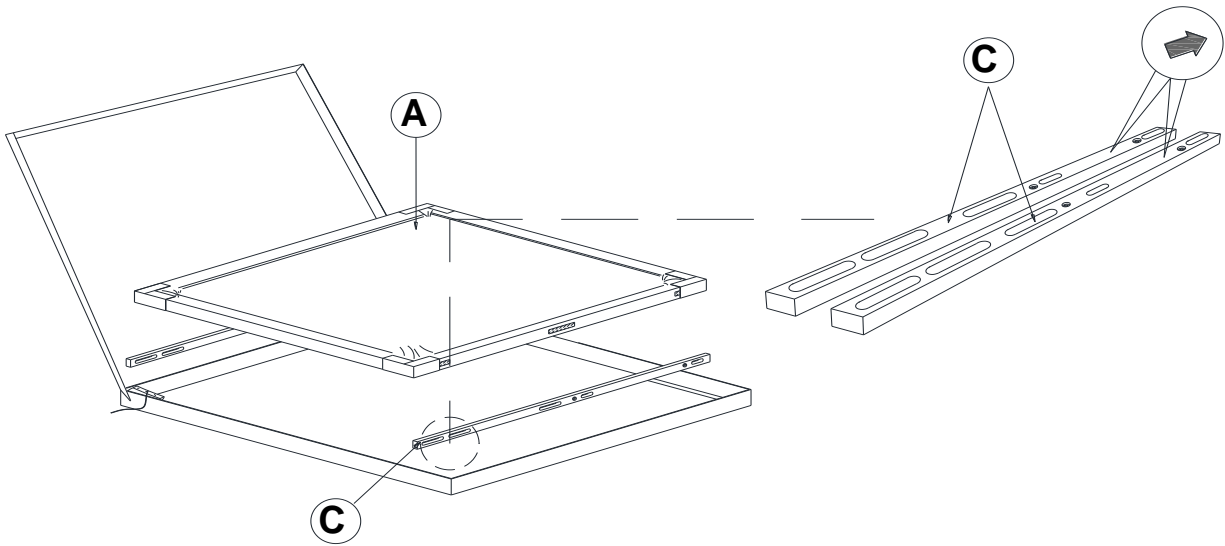

STEP 2

ARROW MARKING FACE UPWARD

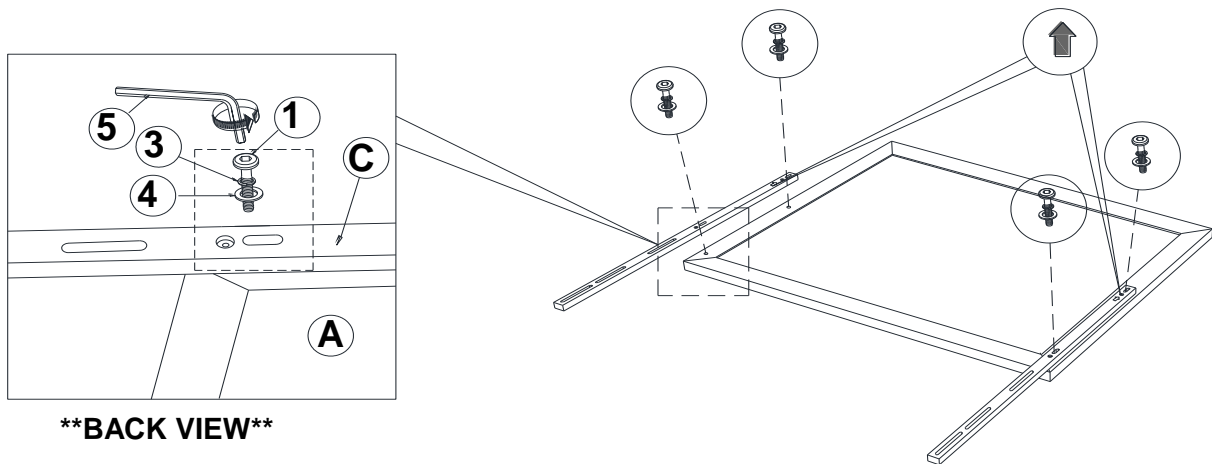

ITEM: **205114**

ASSEMBLY INSTRUCTIONS

STEP 3

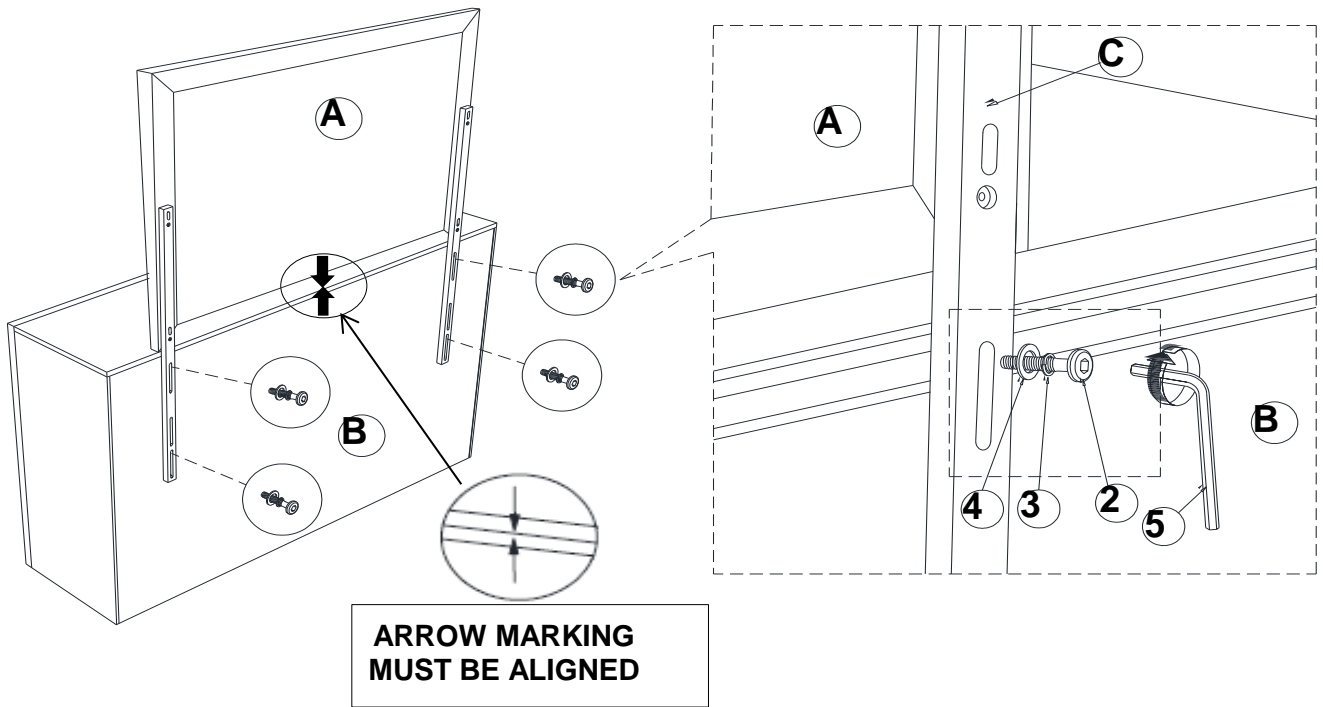

STEP 4
COMPLETE



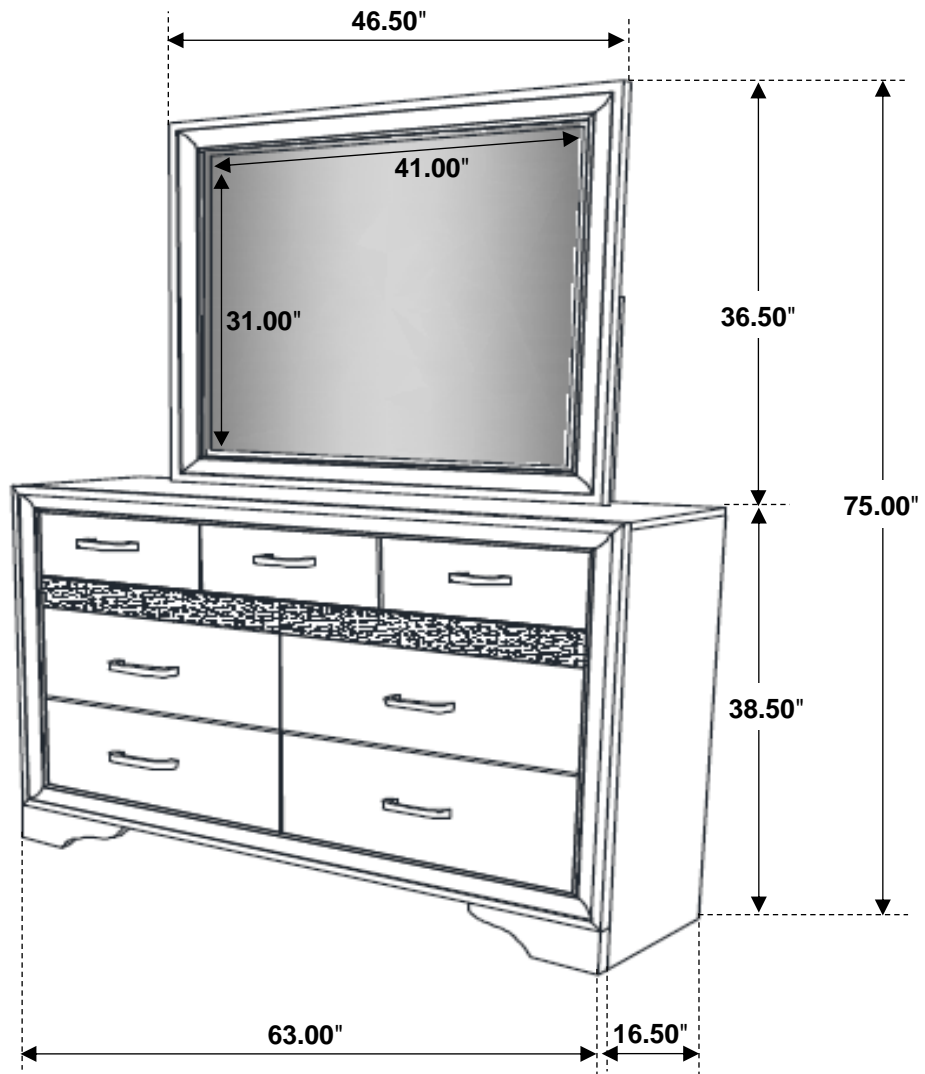

Note: Dimension tolerance $\pm 5\%$