

Assembly Instructions

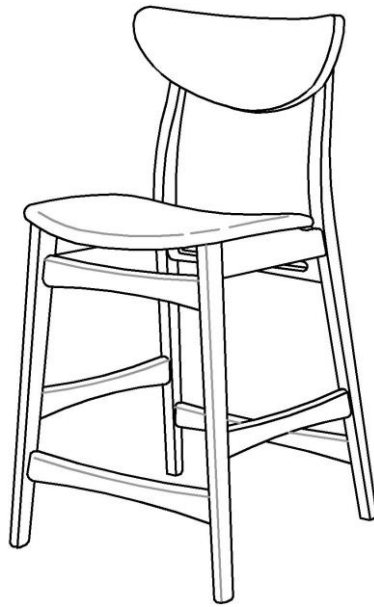

Caution : You must read this before you proceed





BAR STOOL

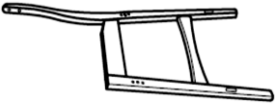
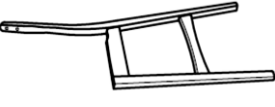



WARNING: These barstools are intended only for normal use with all four legs on the ground. These consumer barstools have relatively thin legs and are not designed to be sat in with only two chair legs on the ground (as from tipping back, forward, or to the side), and such can cause stress and failure of one or more barstool legs. Any misuse of the barstools voids any warranties, express or implied.

Part List

Label	Picture	Description	QTY
A		Left Side Frame (A)	1
B		Right Side Frame (B)	1
C		Front Stretcher	1

D		Back Stretcher	1
E		Front Rail	1
F		Back Rail	1
G		Top Rest	1
H		Cushion Seat	1

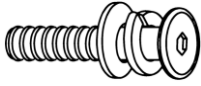
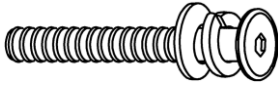
Hardware

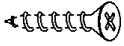
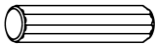
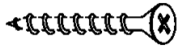
Label	Picture	Description	QTY
①		JCBC M6 x 25mm + S/W M6 + F/W M6 x 13mm	4
②		JCBC M6 x 45mm + S/W M6 + F/W M6 x 13mm	4
③		Allen Key M4	1
④		L Bracket	4
⑤		CSK Screw M3.5 x 12mm	8
⑥		Wood Dowel M8 x 25mm	2
⑦		FH Screw #8 x 32mm	4

Assembly Preparation

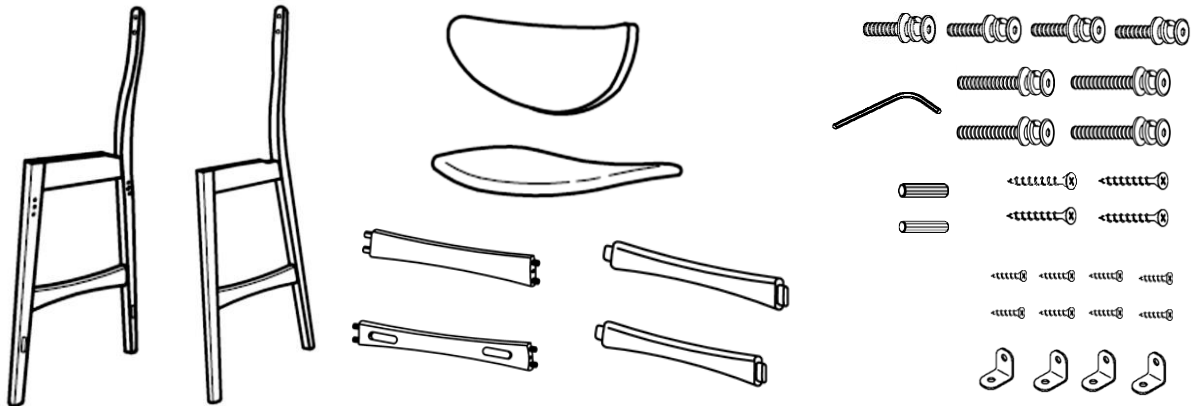
<p>Before Beginning Assembly:</p>			
-----------------------------------	--	--	--



- Read instructions, cover to cover-



- Have 2 adults on hand for assembly-



- Do not assemble on flooring or carpet-



- Assemble on a clean non-marring surface (packing foam)-



- Save all packaging until finished-

Assembly Steps

Overview

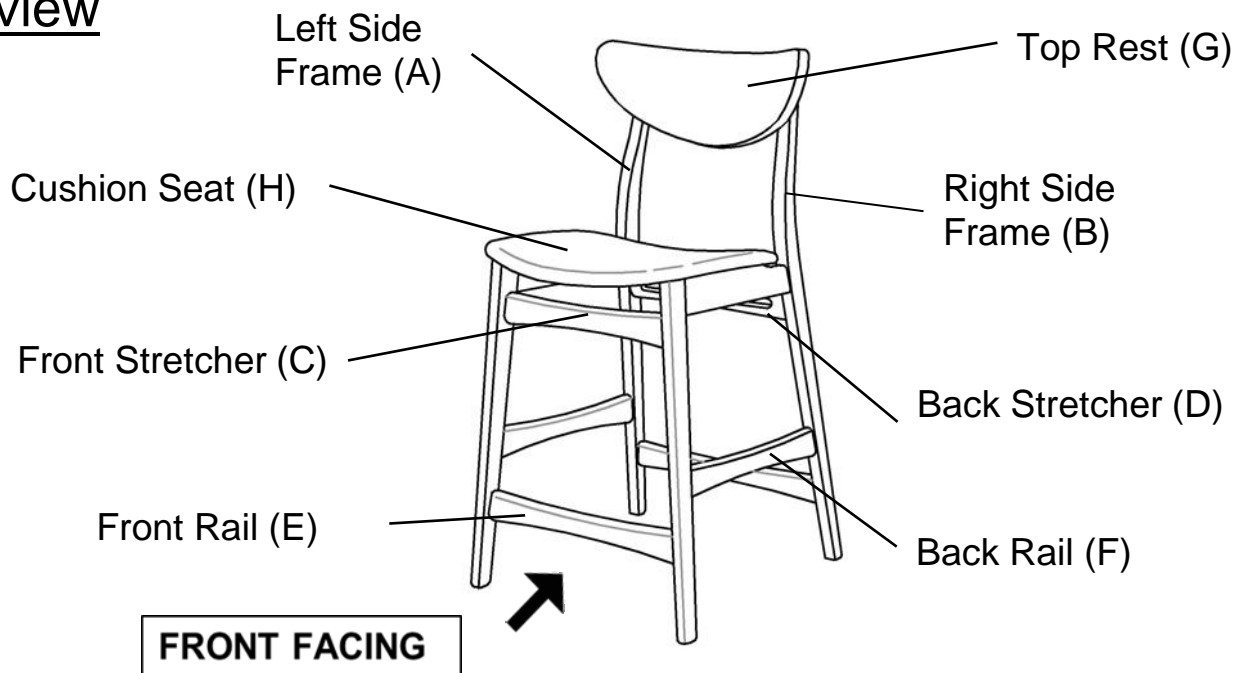

This Bar Stool has multiple parts and may require up to some 30 minutes to assemble. To give you an overview of the Bar Stool parts, the above picture is to help you put the various parts into perspective. Please read through the instructions below to familiarise yourself with the parts and steps before assembly.

Assembly Steps

Step 1

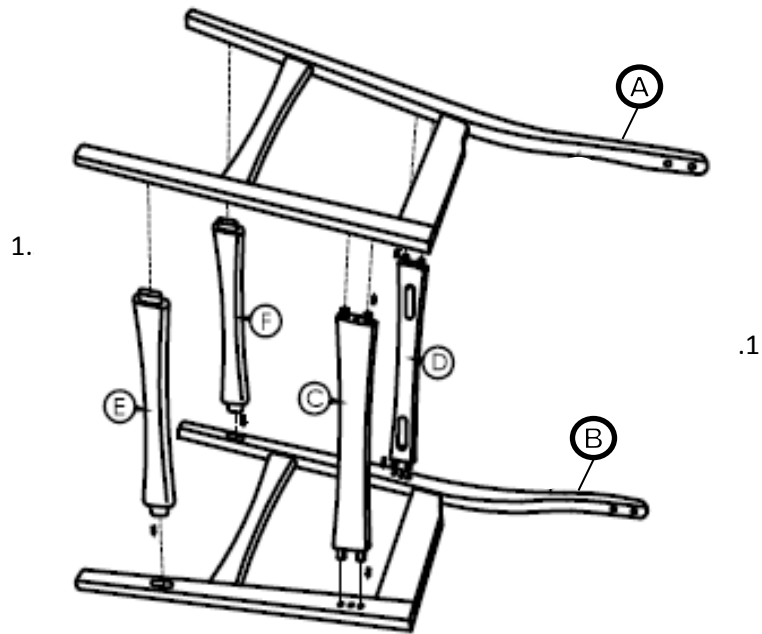

- 1.1 Place the Right Side Frame (A) and Left Side Frame (B) as shown.
- 1.2 Align the tenon of front stretcher(C) with the mount position of Side Frames.
- 1.3 Align the tenon of back stretcher(D) with the mount position of Side Frames.
- 1.4 Align the tenon of Front Rail (E) with the mount position of Side Frames.
- 1.5 Align the tenon of Back Rail (F) with the mount position of Side Frames.

Step 2

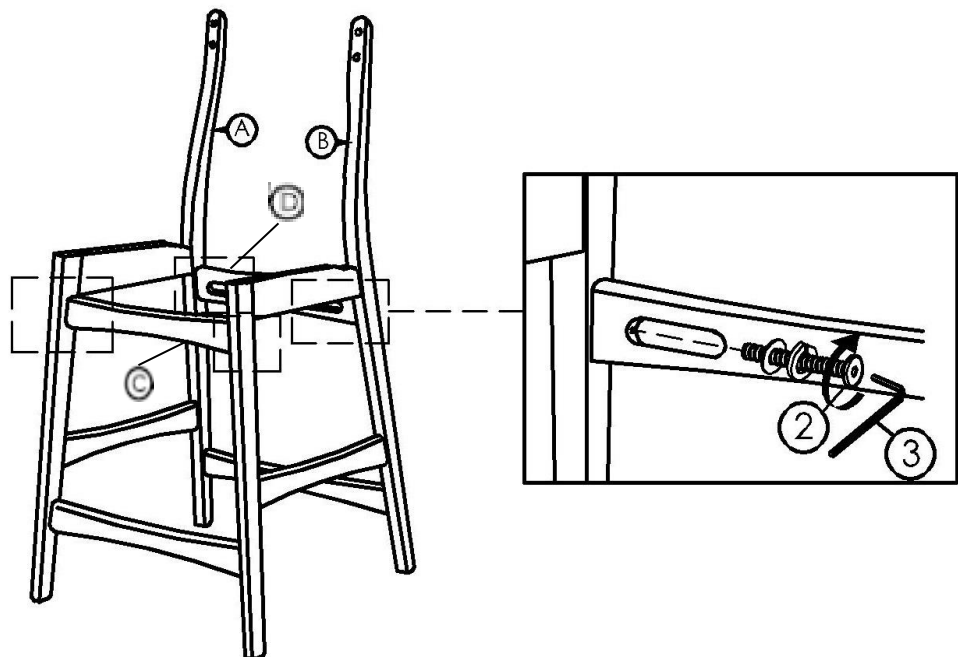

Then, fix the Front Sretcher (C) and Back Sretcher (D) with JCBC Bolt ② + Spring Washer + Flat Washer using Allen Key ③.

DO NOT FULLY TIGHTEN SCREWS.

Step 3

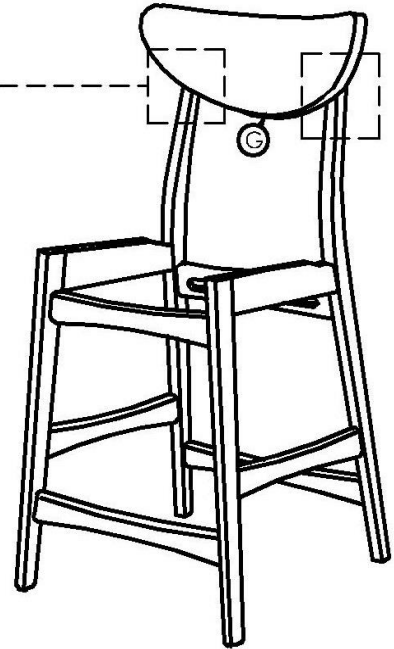
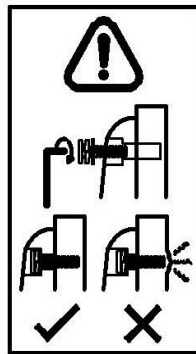
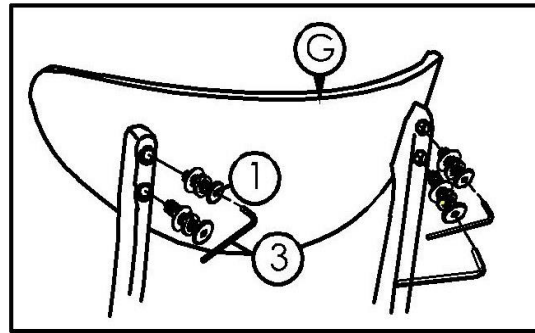

Place the Top Rest (G) on the back frame as shown above.
Then, fix the Top Rest (G) with JCBC Bolt ① + Spring Washer + Flat Washer using Allen Key ③.

DO NOT FULLY TIGHTEN SCREWS.

Step 4

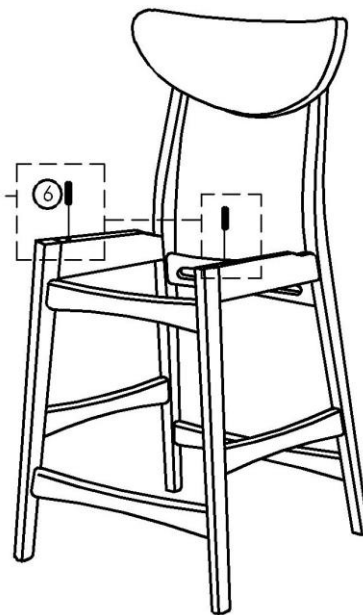
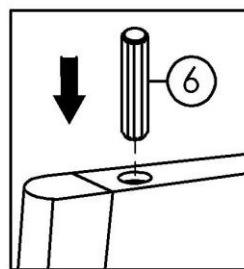

Place Wood Dowel ⑥ on the Side Frame as shown above.

Step 5

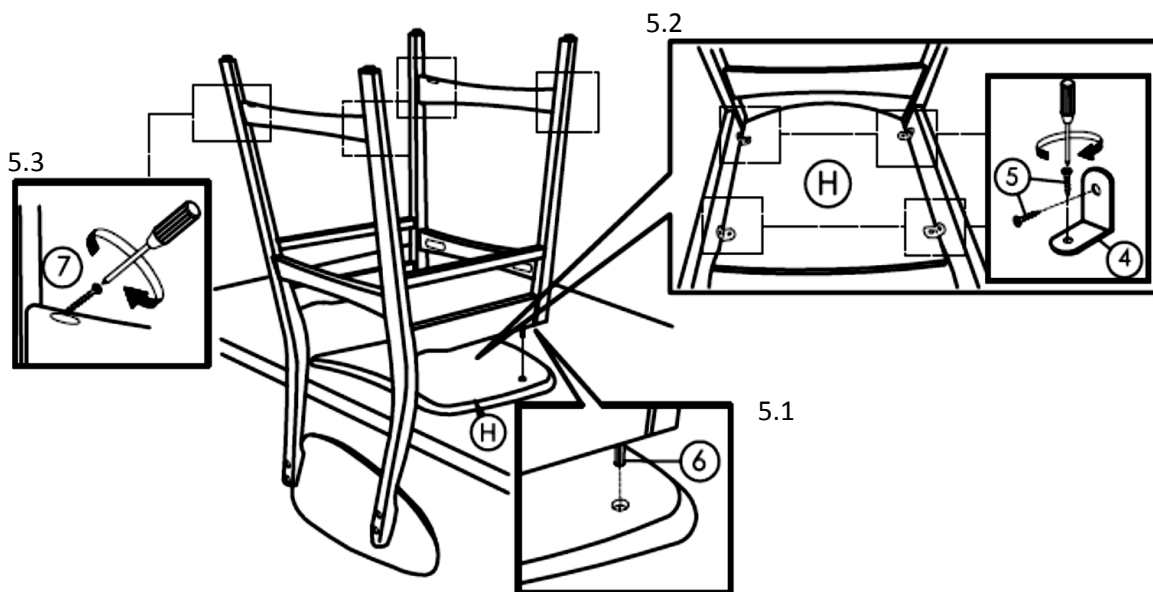

5.1 Place the Cushion Seat(H) on the table, then put the assembled chair parts in Step4 to fix the Cushion Seat (H) as shown.

Align the the Wood Dowel ⑥ into the tenon of Cushion Seat (H) as shown above.

5.2 Then, fix the Cushion Seat (H) with L-Bracket ④ and Screws ⑤ using Screwdriver not provided.

5.3 Fix the Front Rail (E) And Back Rail (F) with Screw ⑦ using Screwdriver (not provided).

DO NOT FULLY TIGHTEN ALL THE BOLT AND SCREWS NOW.

Step 6



Turn clockwise or anti-clockwise to adjust leg leveller.

Turn clockwise or anti-clockwise to adjust leg leveller. The **Max** height during 0.25~0.8inch.

Step 7

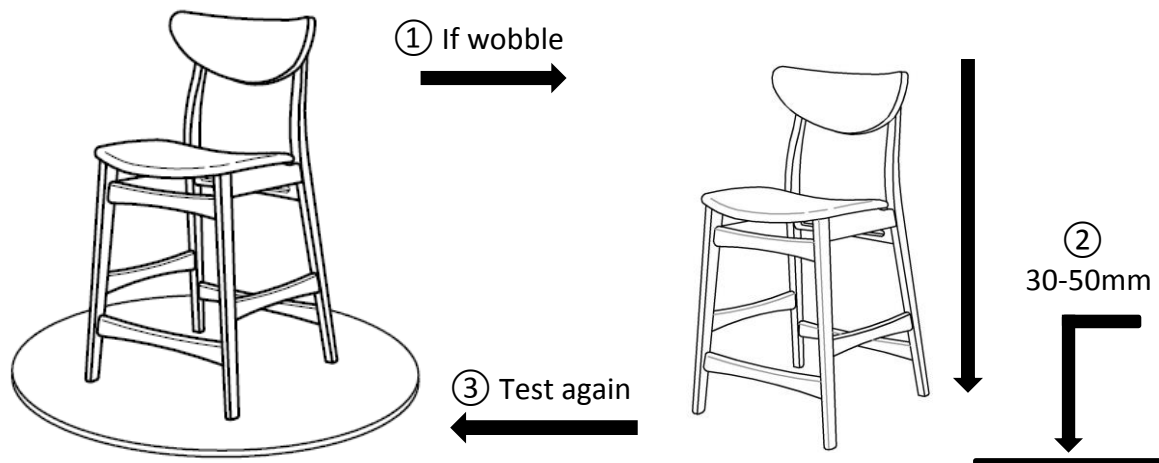

Place the bar stool on a Level Surface to check if it wobbles. Loosen the bolts and lift the bar stool some 30cm to 50cm high from the ground, keep your feet and toes well away from the drop zone, and drop the bar stool freely and vertically with the four legs, hitting the ground at the same time. This Drop Test will help to ensure that all the bolts and gaps to all reach full alignment.

Test again for evenness on Level Surface.

If no wobbles are found, proceed to tighten all the Bolts.

Caution: When tightening the Bolts, tighten sequentially.

Do not tighten any screw fully and then towards the next one, this would cause the frame to warp. If it still wobbles, loosen the bolts and execute this same drop test.

If the bar stool is not Stable it could lead to damage to the product.

Step 8





















Inspect and make sure all parts are connected.

The bar stool is ready for use.

Caution: This bar stool can only be used on a flat, level surface.

Care & Maintenance

-   ● Do not put hot items directly on furniture surface
 -   ● Do not clean furniture with harsh cleansers or polish.
 -   ● To obtain the longest lifespan of your outdoor products, minimizing exposure to direct sunlight is recommended.
 -   ● Children should not climb or jump on the furniture.
 -   ● Do not write on furniture without a padded barrier to protect the surface.
 -   ● To obtain the longest lifespan of your outdoor products, avoid extended and lengthy exposure to rain, snow, and direct sunshine. Whenever possible cover the product and /or place under patio or awnings.
 -   ● Not for commercial use. For residential use only .
 -   ● Stains may be removed with mild soap solution and damp cloth.
-
-   ● Dust and pick-up spills using a clean, non-colored, lint-free cloth .

Questions & Answers about Proposition 65

• What is Proposition 65?

Proposition 65 requires businesses to provide warnings to Californians about significant exposures to chemicals that cause cancer, birth defects or other reproductive harm. These chemicals can be in the products that Californians purchase, in their homes or workplaces, or that are released into the environment. By requiring that this information be provided, Proposition 65 enables Californians to make informed decisions about their exposures to these chemicals.

Proposition 65 also prohibits California businesses from knowingly discharging significant amounts of listed chemicals into sources of drinking water.

Proposition 65 requires California to publish a list of chemicals known to cause cancer, birth defects or other reproductive harm. This list, which must be updated at least once a year, has grown to include approximately 900 chemicals since it was first published in 1987.

• What types of chemicals are on the Proposition 65 list?

The list contains a wide range of naturally occurring and synthetic chemicals that include additives or ingredients in pesticides, common household products, food, drugs, dyes, or solvents. Listed chemicals may also be used in manufacturing and construction, or they may be byproducts of chemical processes, such as motor vehicle exhaust.

• What does a warning mean?

If a warning is placed on a product label or posted or distributed at a workplace, a business, or in rental housing, the business issuing the warning is aware or believes that it is exposing individuals to one or more listed chemicals.

By law, a warning must be given for listed chemicals unless the exposure is low enough to pose no significant risk of cancer or is significantly below levels observed to cause birth defects or other reproductive harm.

• Where can I get more information on Proposition 65?

If you have specific questions on the administration or implementation of Proposition 65, you can contact OEHHA's Proposition 65 program at P65.Questions@oehha.ca.gov, or by phone at (916) 445-6900.