

ASSEMBLY INSTRUCTIONS

INSTRUCTIONS DE MONTAGE

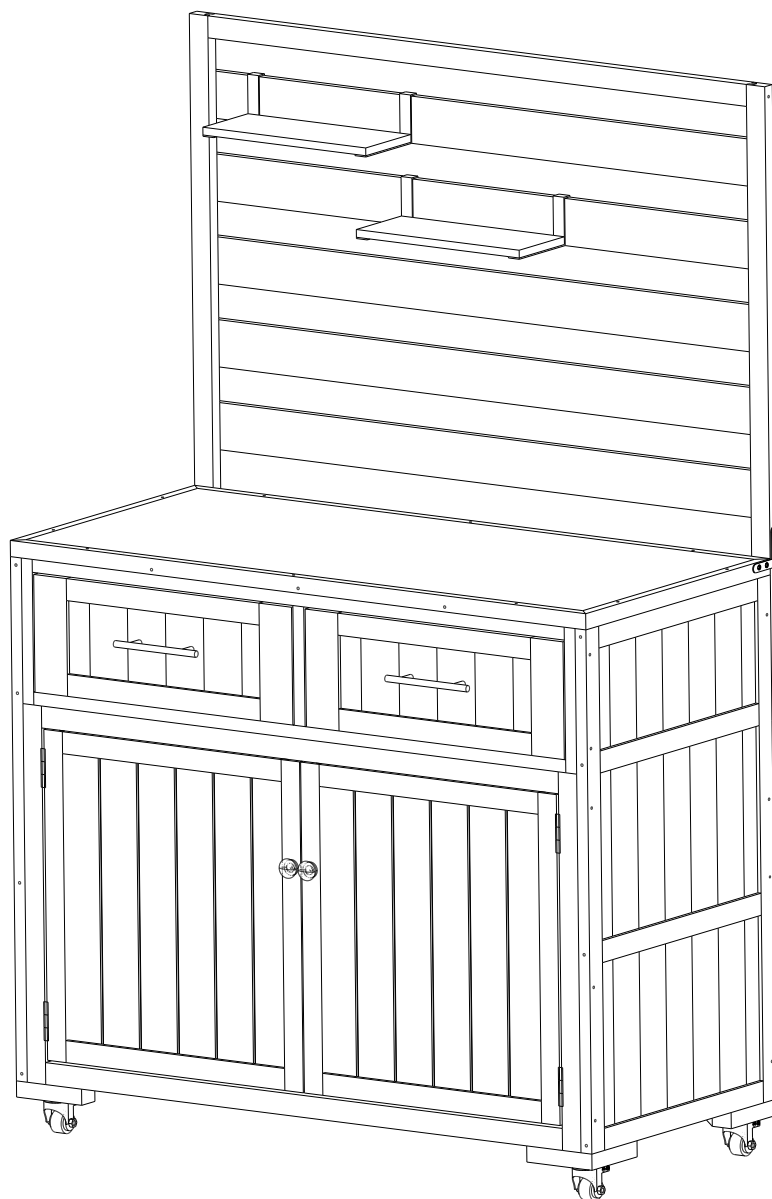

IMPORTANT NOTE :

- ① PLACE ALL PARTS ON A CLEAN AND SMOOTH SURFACE SUCH AS A RUG OR CARPET TO AVOID THE PARTS FROM BEING SCRATCHED.
- ② BEFORE YOU BEGIN, KINDLY FOLLOW THE ASSEMBLY INSTRUCTIONS STEP BY STEP.
- ③ DO NOT TIGHTEN ALL SCREWS AND BOLTS UNTIL THIS ITEM IS FULLY SET-UP.







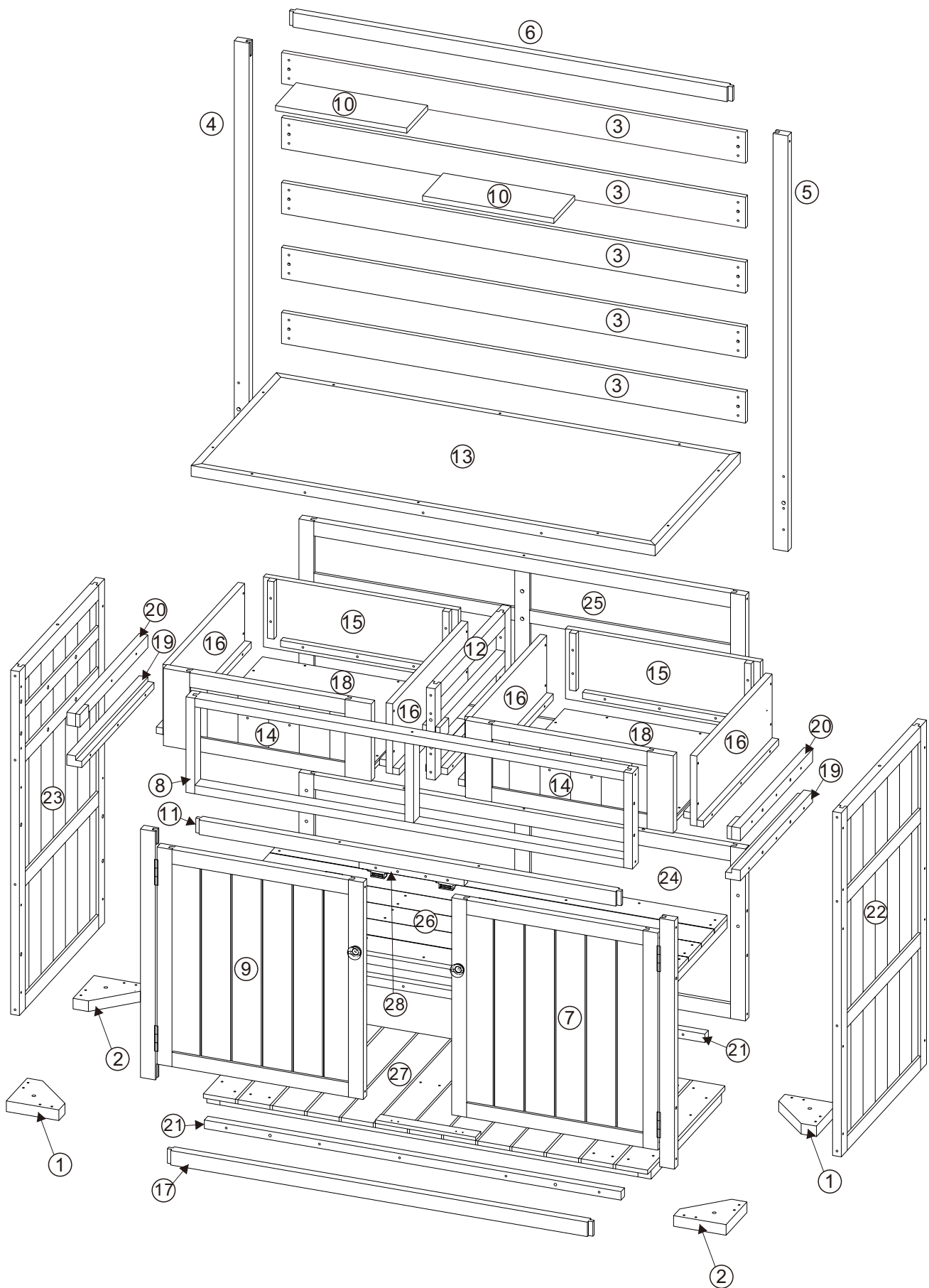







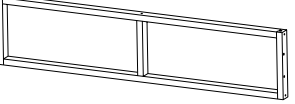

NOTE IMPORTANTE:

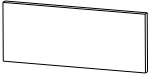
- ① PLACEZ TOUTES LES PIÈCES SUR UNE SURFACE PROPRE ET LISSE TELLE QU'UN TAPIS OU UN TAPIS POUR ÉVITER LES PIÈCES D'ÊTRE RAYÉES.
- ② AVANT DE COMMENCER, VEUILLEZ SUIVRE LES INSTRUCTIONS D'ASSEMBLAGE ÉTAPE PAR ÉTAPE.
- ③ NE SERREZ PAS TOUTES LES VIS ET LES BOULONS TANT QUE CET ARTICLE N'EST PAS ENTIÈREMENT INSTALLÉ.

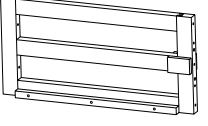
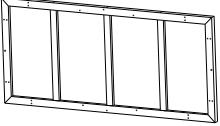
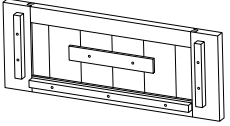
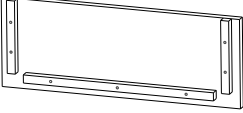
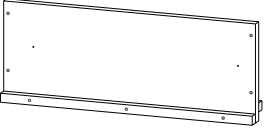

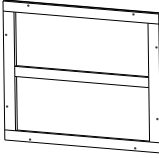
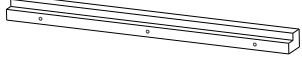
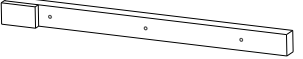



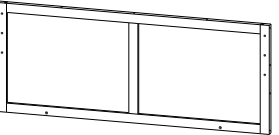
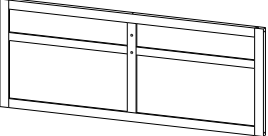
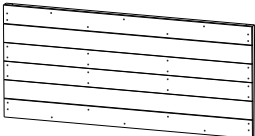
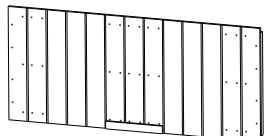
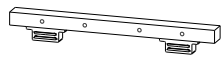



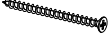
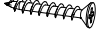
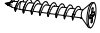

Detail View Vue détaillée

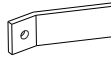
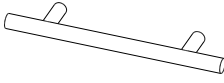

Part List Liste des pièces

1		2		3		4	
Base 1 2PCS		Base 2 2PCS		Shelf panel Panneau d'étagère 5PCS		Left vertical partition of the storage rack Cloison verticale gauche du rayonnage de stockage 1PC	
5		6		7		8	
Right vertical partition of the storage rack Cloison verticale droite du rayonnage de stockage 1PC		The slat of storage rack La latte du rayonnage de stockage 1PC		Right door Porte gauche 1PC		Upper front panel Panneau avant supérieur 1PC	
9		10		11		12	
Left door Porte gauche 1PC		Movable shelf panel Panneau d'étagère mobile 2PCS		Upper crossbar of lower front panel Barre transversale supérieure du panneau avant inférieur 1PC		Middle panel Panneau central 1PC	
13		14		15		16	
Table top Dessus de table 1PC		Front panel of drawer Panneau avant du tiroir 2PCS		Back panel of drawer Panneau arrière du tiroir 2PCS		Side panel of drawer Panneau latéral du tiroir 4PCS	
17		18		19		20	
Lower crossbar of lower front panel Barre transversale inférieure du panneau avant inférieur 1PC		Bottom panel of drawer Panneau inférieur du tiroir 2PCS		Side panel support strip 1 Bande de support pour panneau latéral 1 2PCS		Side panel support strip 2 Bande de support pour panneau latéral 2 2PCS	
21		22		23		24	
Front & back panel support strip Bande de support pour panneau avant et arrière 2PCS		Right side panel Panneau latéral 1PC		Left side panel Panneau latéral gauche 1PC		Lower back panel Panneau inférieur du dos 1PC	
25		26		27		28	
Upper back panel Panneau arrière supérieur 1PC		Shelf Étagère 1PC		Bottom panel Panneau inférieur 1PC		Magnetic wooden strip Bandes de bois magnétique 1PC	

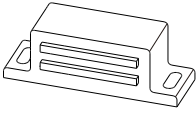
Hardware List
Liste du matériel

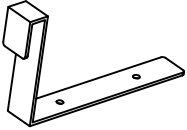
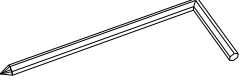
<p>A</p>  <p>3.5*60 Ph zinc screws Vis de zinc ph 6+1 pcs</p>	<p>B</p>  <p>3.5*50 Ph zinc screws Vis de zinc ph 12+1pcs</p>	<p>C</p>  <p>3.5*40 Ph zinc screws Vis de zinc ph 46+1pcs</p>	<p>D</p>  <p>3.0*35 Ph zinc screws Vis de zinc ph 18+1pcs</p>
<p>E</p>  <p>3.0*30 Ph zinc screws Vis de zinc ph 6+1pcs</p>	<p>F</p>  <p>3.0*25 Ph zinc screws Vis de zinc ph 52+1pcs</p>	<p>G</p>  <p>3.0*16 Ph zinc screws Vis de zinc ph 16+1pcs</p>	<p>H</p>  <p>3.0*14 Ph zinc screws Vis de zinc ph 12+1pcs</p>
<p>I</p>  <p>M4*25 Ph zinc bolt Boulon de zinc ph 2+1pcs</p>	<p>J</p>  <p>M4*18 Ph zinc bolt Boulon de zinc ph 4+1pcs</p>	<p>K</p>  <p>Laminated nail Clou laminé 4pcs</p>	<p>L</p>  <p>Brake wheel Roue de frein 2pcs</p>
<p>M</p>  <p>Fixed wheel Roue fixe 2pcs</p>	<p>N</p>  <p>Drawer stopper Butée de tiroir 4pcs</p>	<p>O</p>  <p>Door handle Poignée de porte 2pcs</p>	<p>P</p>  <p>Door knob Bouton de por 2pcs</p>
<p>Q</p>  <p>Plastic magnetic collision Collision magnétique plastique 2pcs</p>	<p>R</p>  <p>Open-end Wrench Clé à fourche 1pcs</p>	<p>S</p>  <p>L shape metal Métal en forme de L 2pcs</p>	<p>T</p>  <p>Right-angle iron Cornière en fer 2pcs</p>
<p>U</p>  <p>Ground nail Clou de sol 2pcs</p>	<p>W</p>  <p>Hook Crochet 4pcs</p>	<p>V</p>  <p>Wood dowel Cheville à bois 44+2 pcs</p>	<p>L shape wrench Clé en L 1pcs</p> 

ASSEMBLY TOOLS REQUIRED(NOTINCLUDED)
OUTILS D'ASSEMBLAGE REQUIS (NON INCLUS)

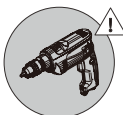

PLEASE BE CAREFUL DO NOT DAMAGE THE HOLE POSITION WHEN YOU USE POWERTOOLS!

VEUILLEZ FAIRE ATTENTION À NE PAS ENDOMMAGER LA POSITION DU TROU LORS DE L'UTILISATION D'OUTILS ÉLECTRIQUES!

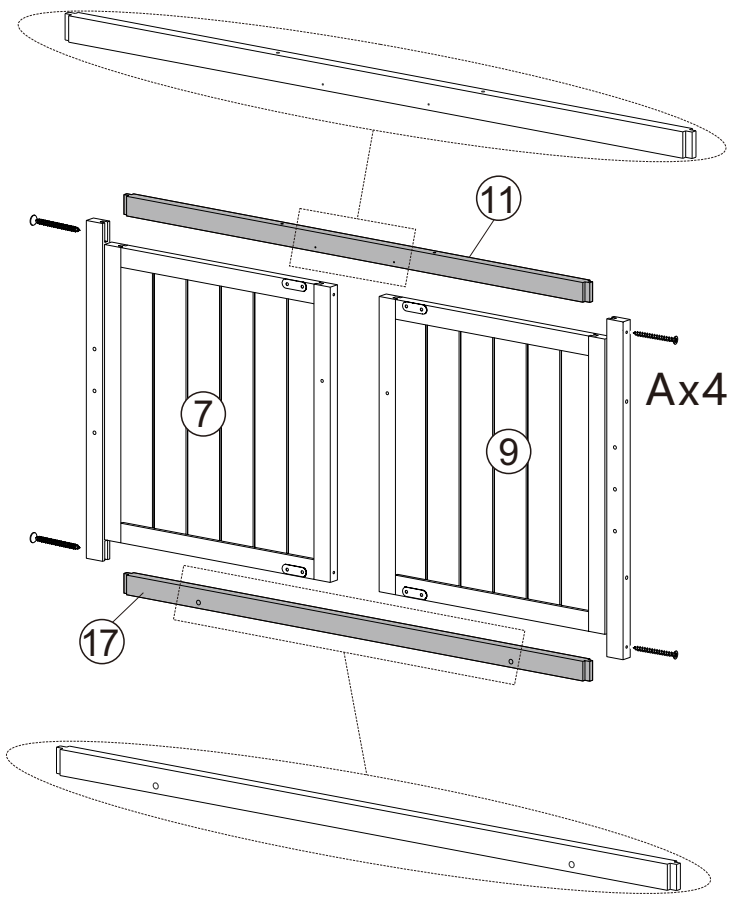

1 Ax4 7 x1 9 x1 11 x1 17 x1

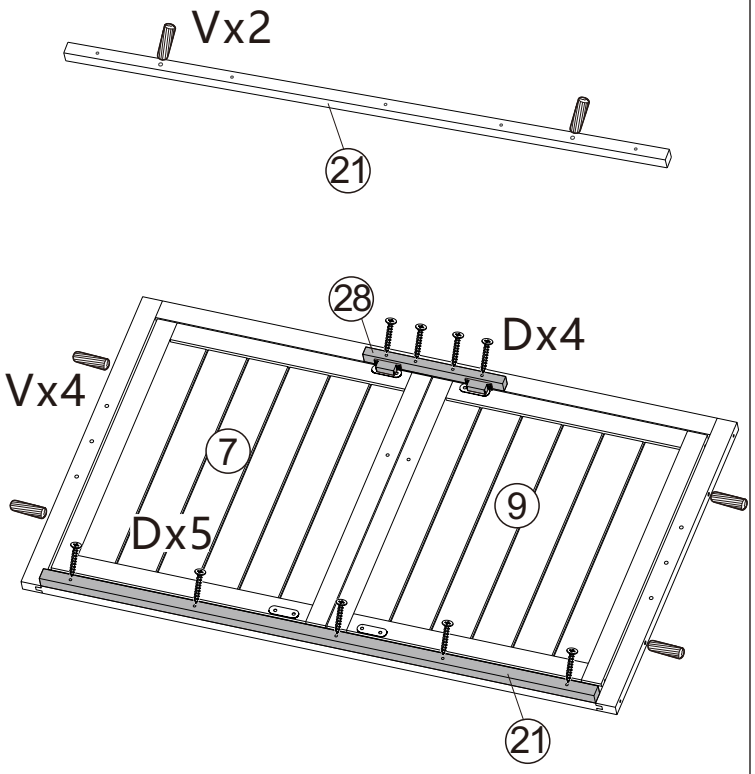

2 Dx9 Vx6 21 x1 28 x1

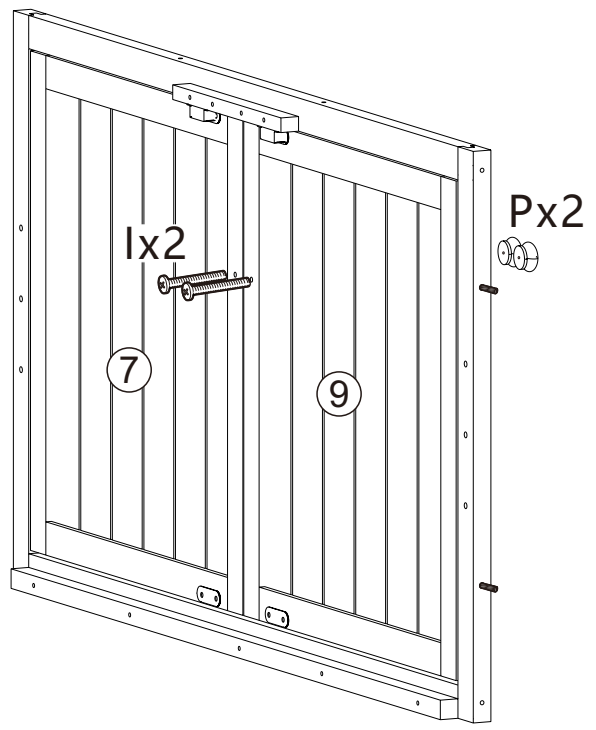

3 Ix2 Px2

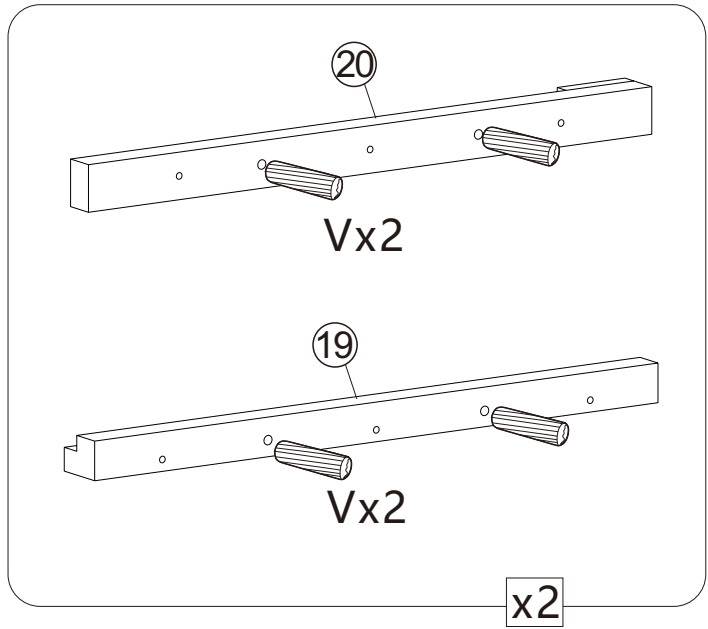

4 Vx8 19 x2 20 x2

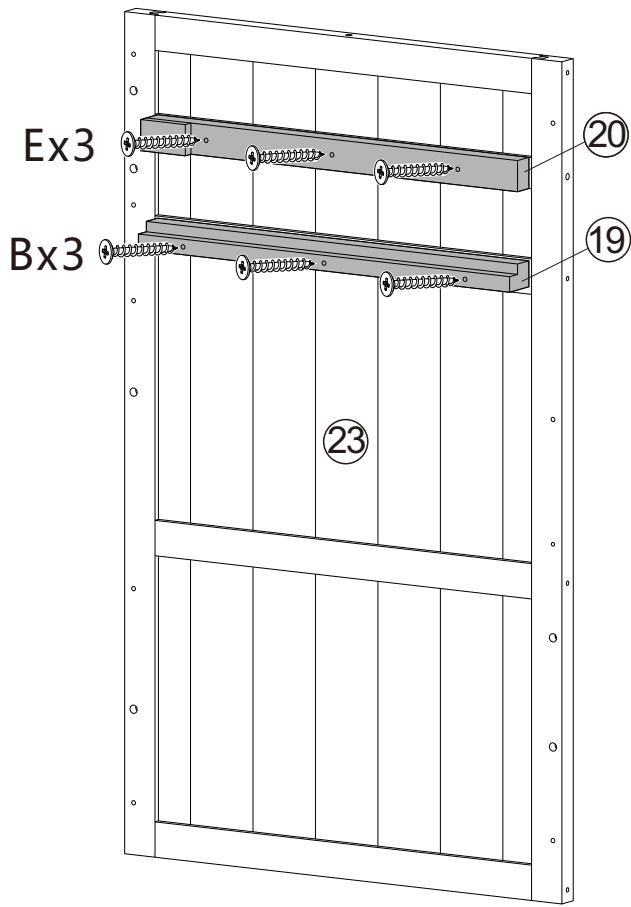

5

Bx3 Ex3 19 x1 20 x1 23 x1

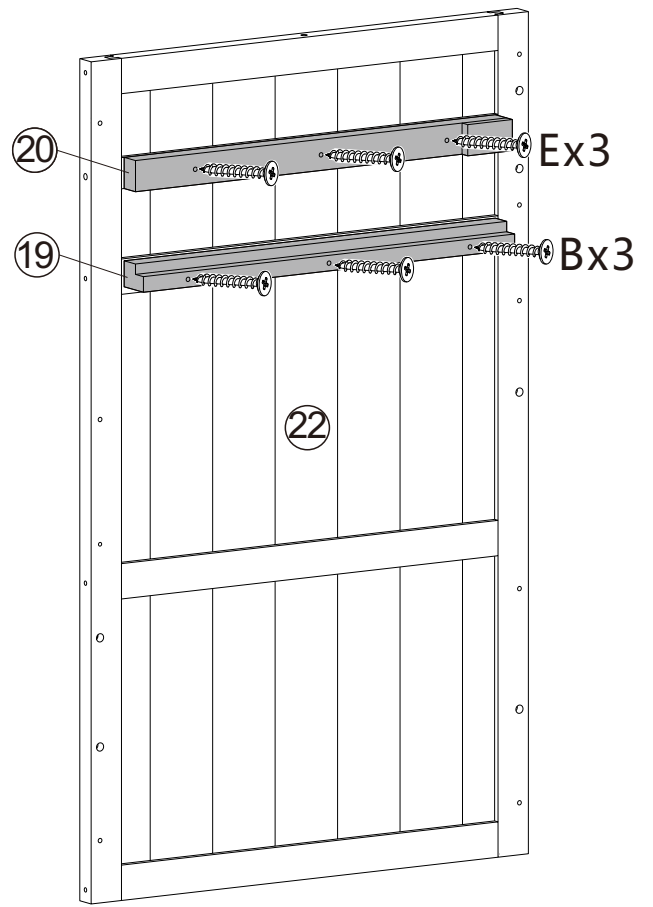

6

Bx3 Ex3 19 x1 20 x1 22 x1

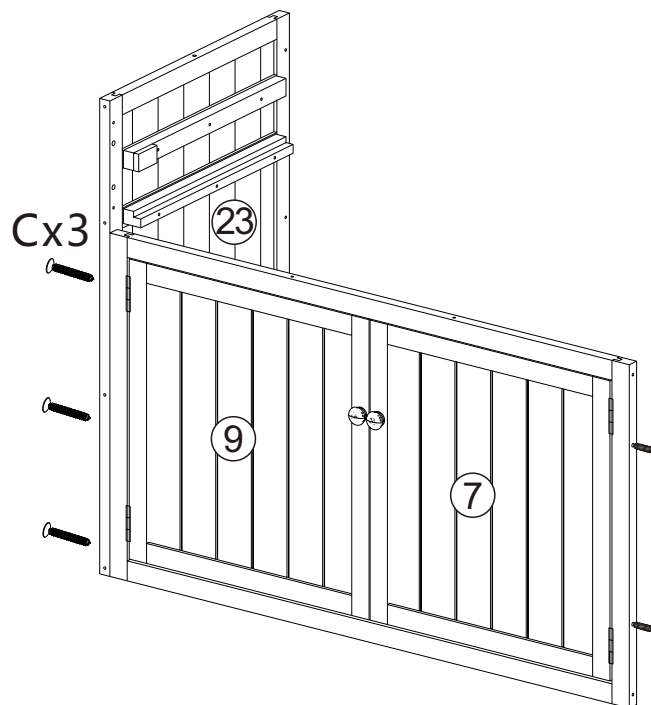

7

Cx3

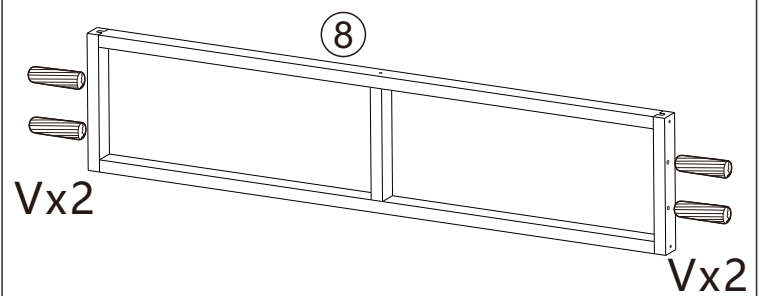

8

Vx4 8 x1

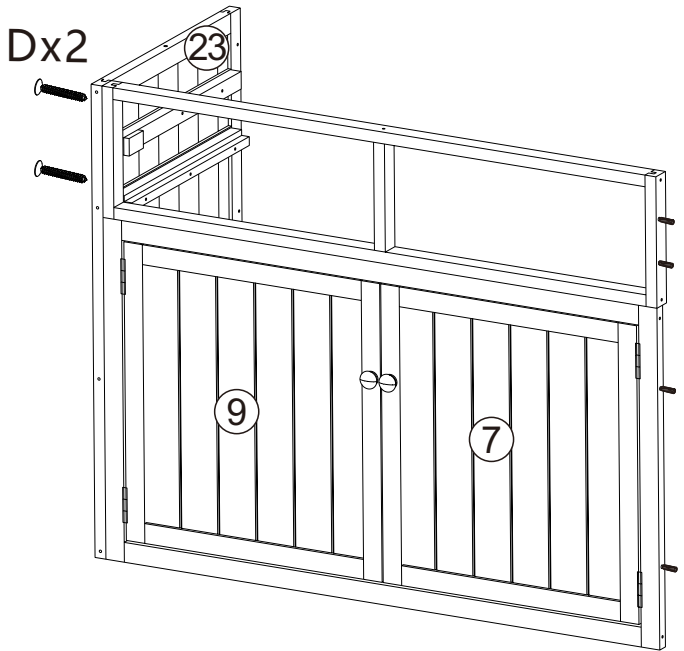

9

Dx2

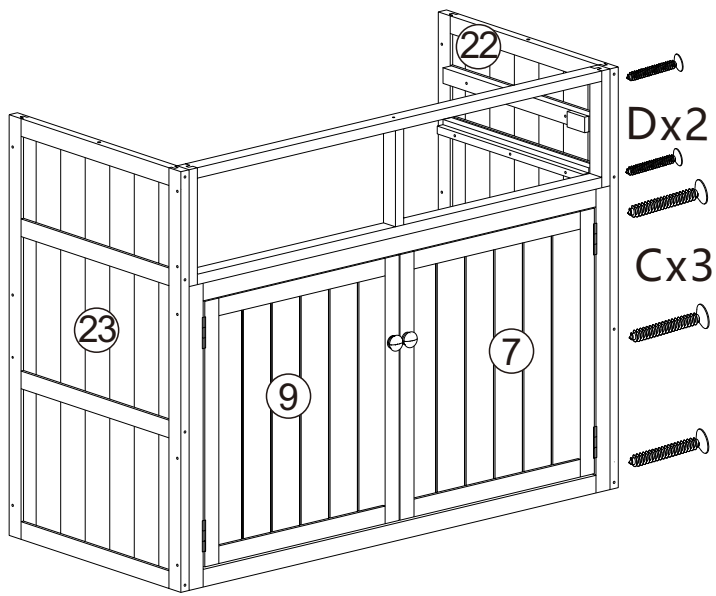

10

Cx3 Dx2

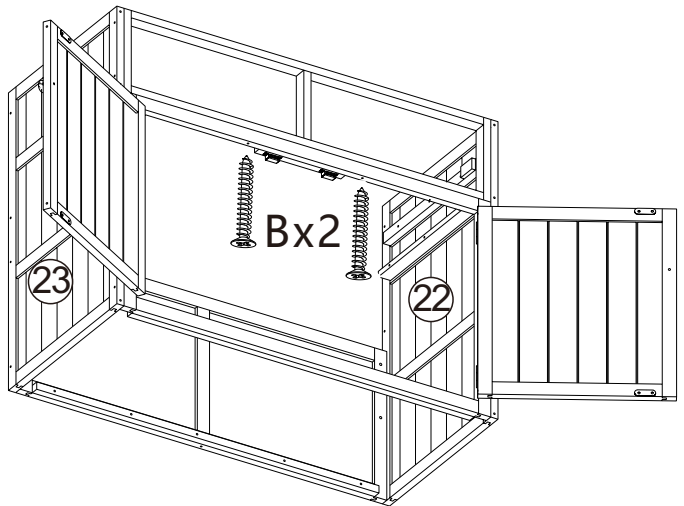

11

Bx2

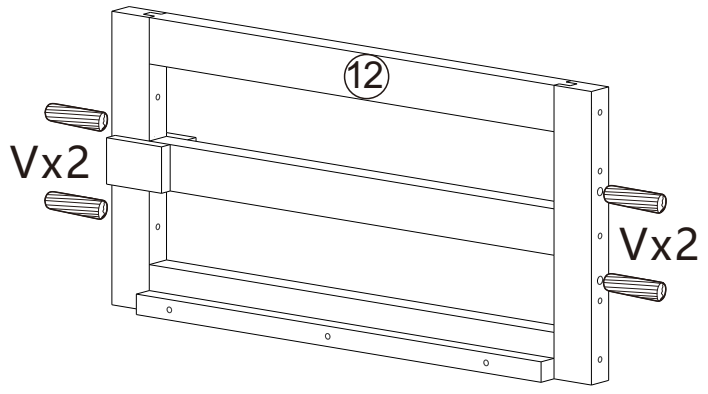

12

Vx4 12x1

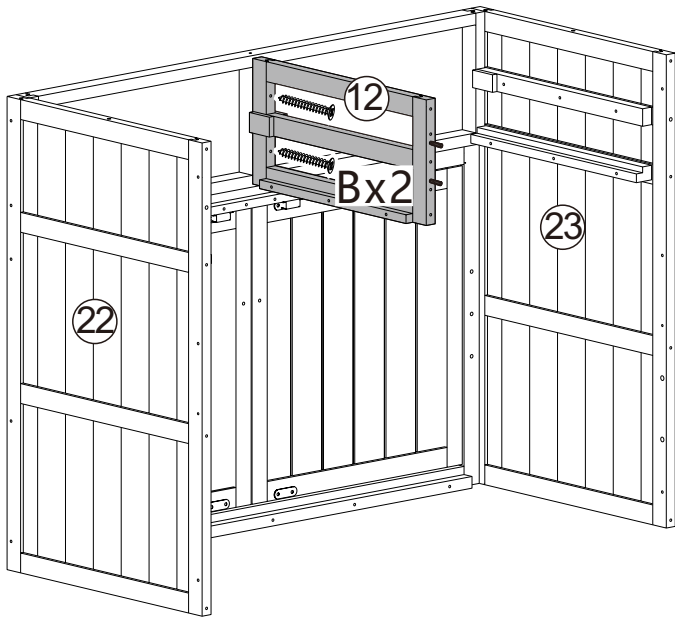

13

Bx2 (12)x1

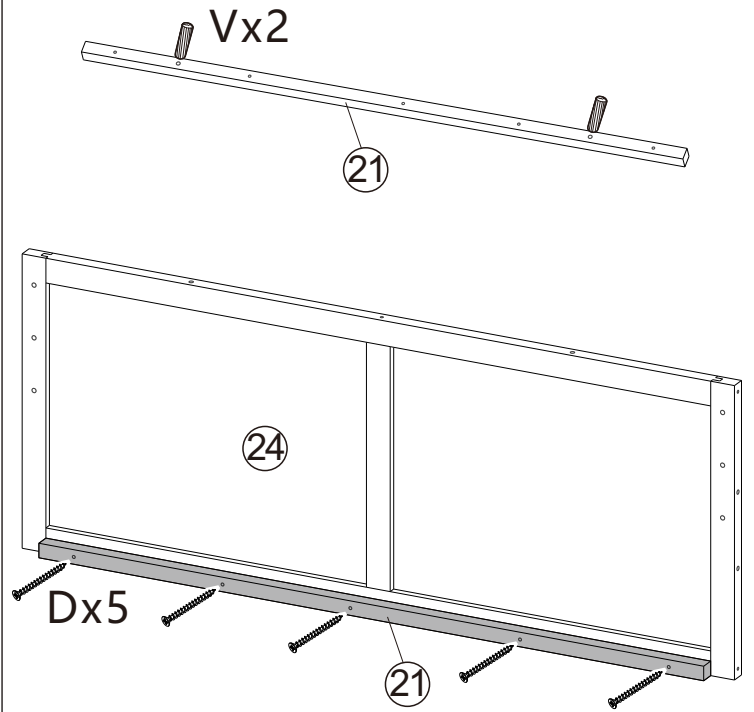

14

Dx5 Vx2 (21)x1 (24)x1

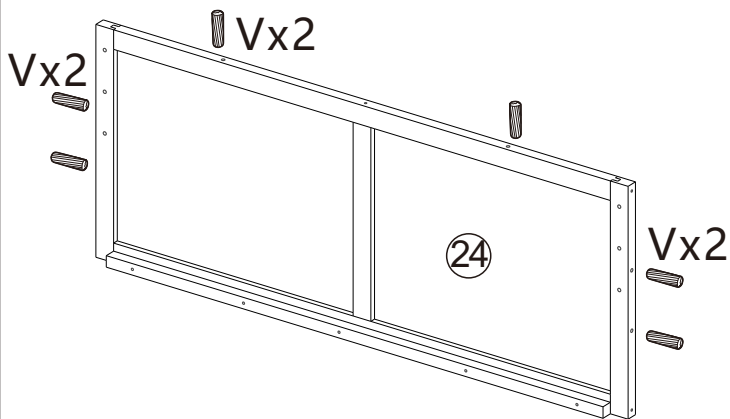

15

Vx6 (24)x1

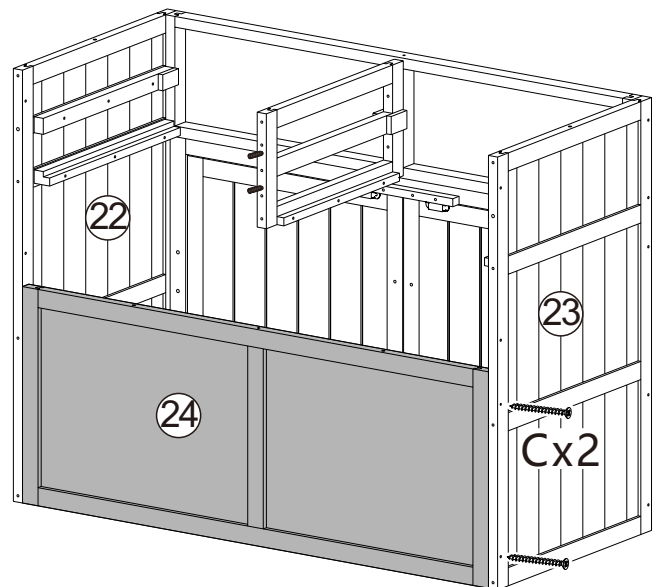

16

Cx2 (24)x1

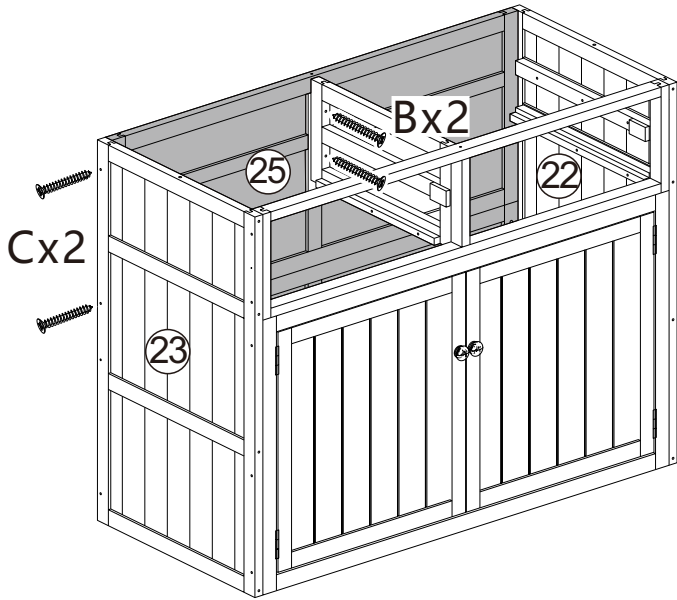

17

Bx2 Cx2 25x1

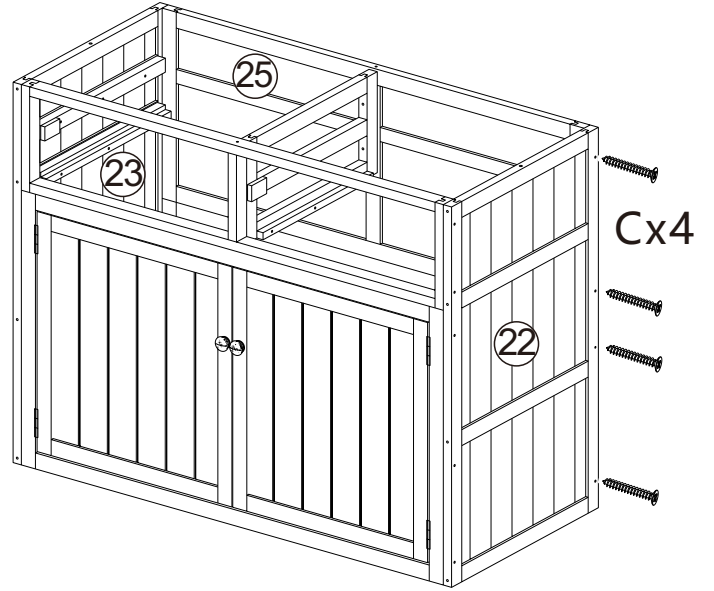

18

Cx4

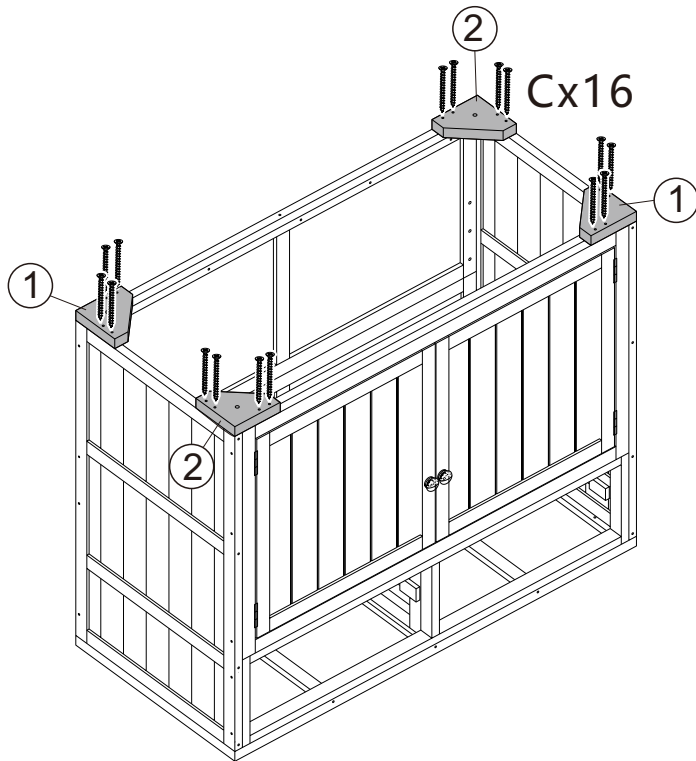

19

Cx16 1x2 2x2

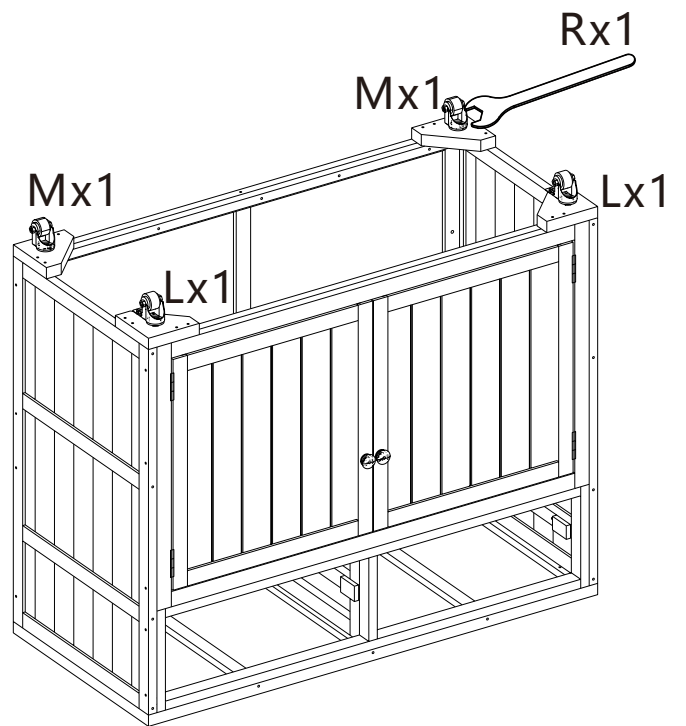

20

Lx2 Mx2 Rx1

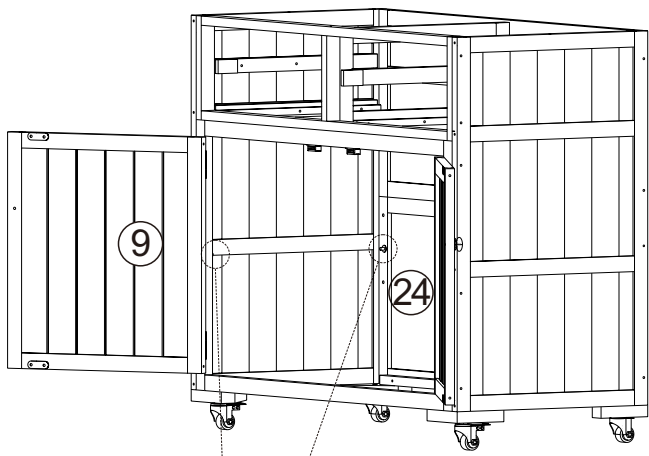

21

Kx2

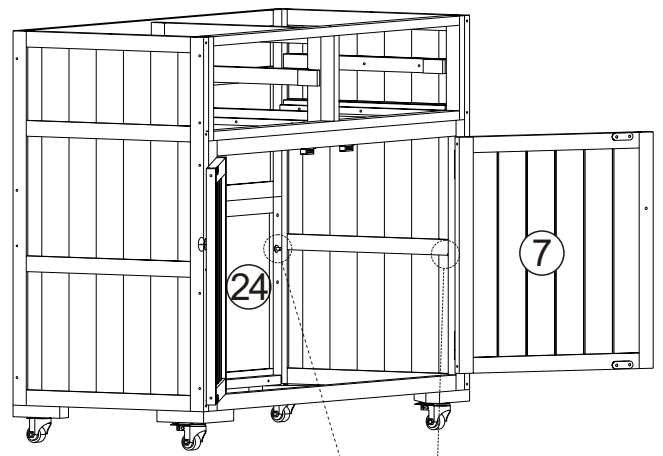

22

Kx2

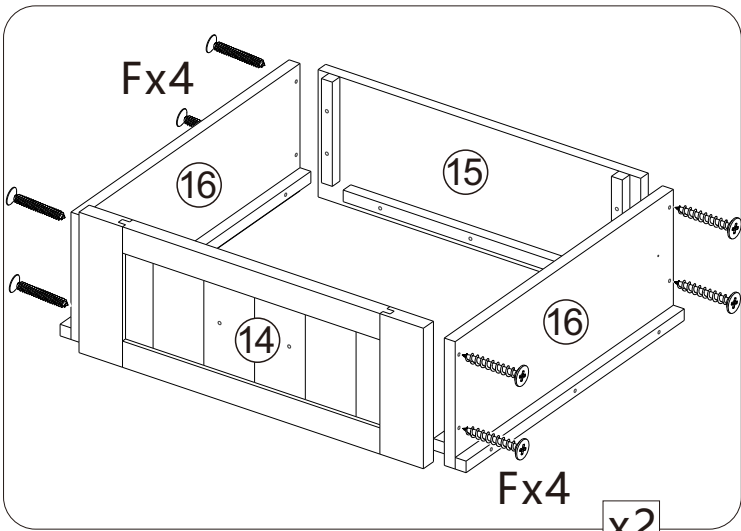

23

Fx16 (14) x2 (15) x2 (16) x4

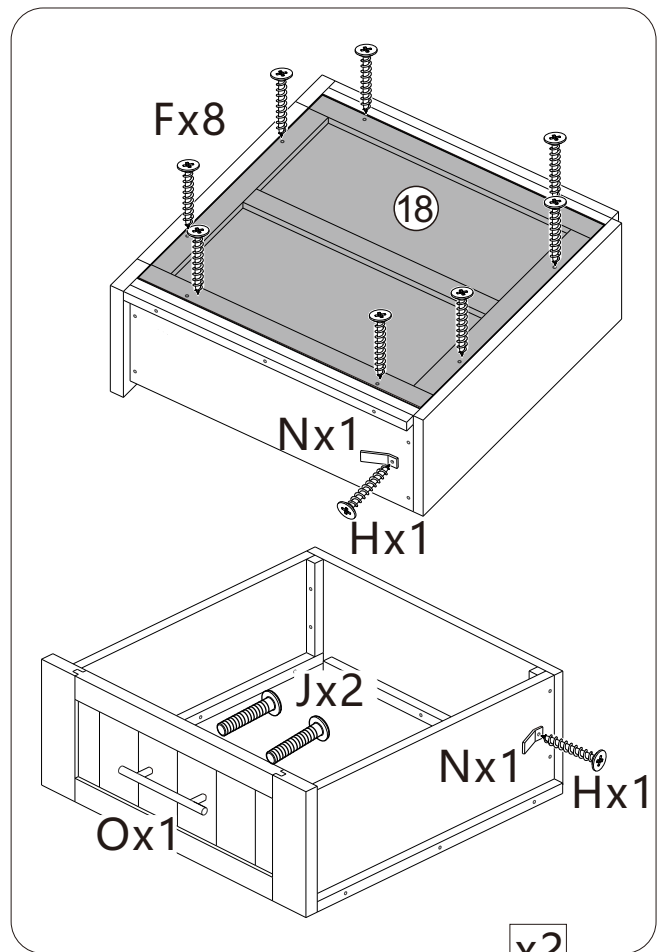

24

Fx16 Jx4 Nx4 Hx4 Ox2 (18) x2

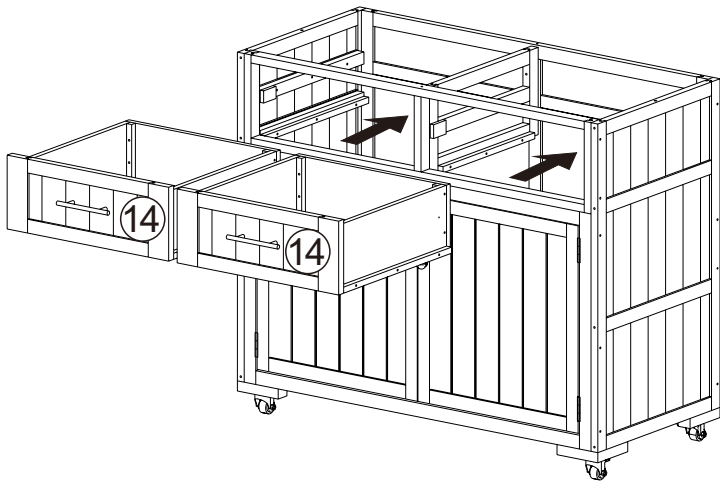

25

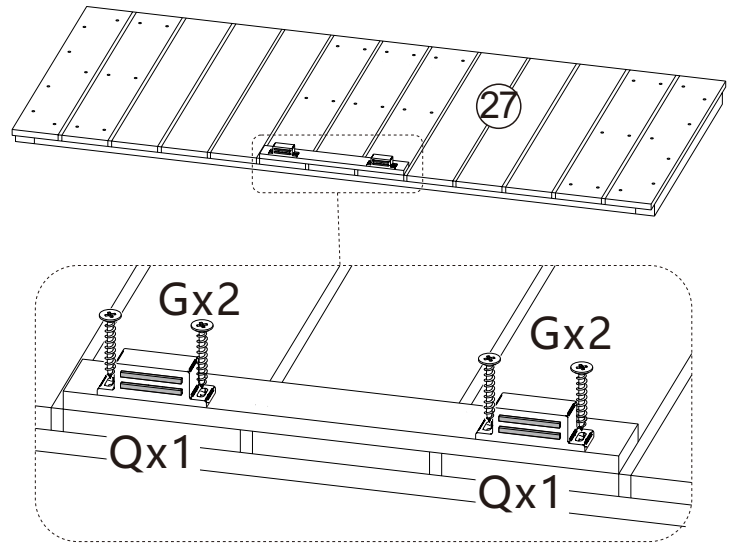

The magnetic collision is flush with the front of the bottom panel

La collision magnétique est alignée avec l'avant du panneau inférieur

26

Gx4 Qx2 (27) x1

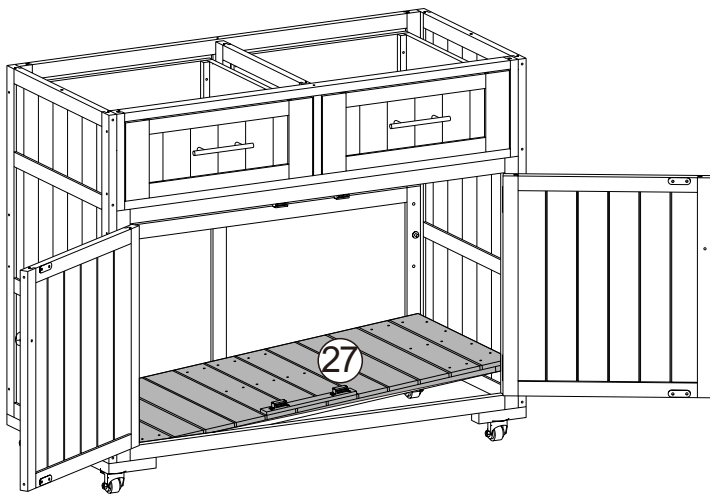

27

(27) x1

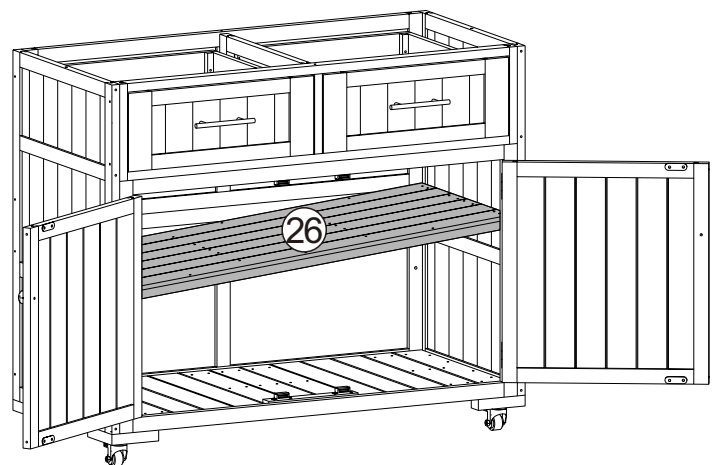

28

(26) x1

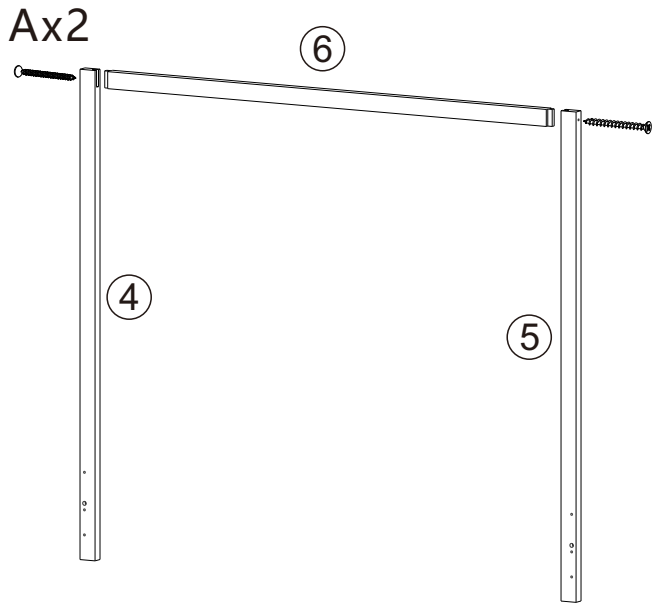

29

Ax2 ④ x1 ⑤ x1 ⑥ x1

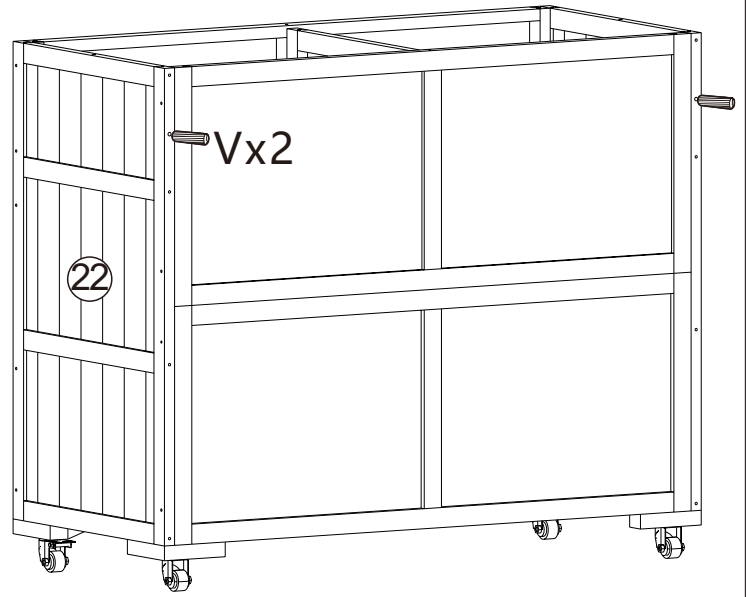

30

Vx2

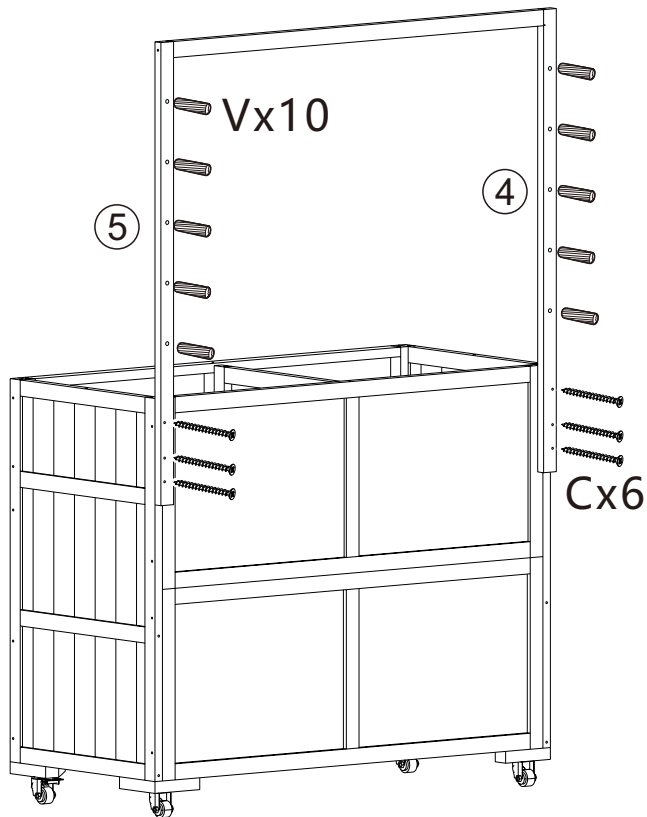

31

Cx6 Vx10

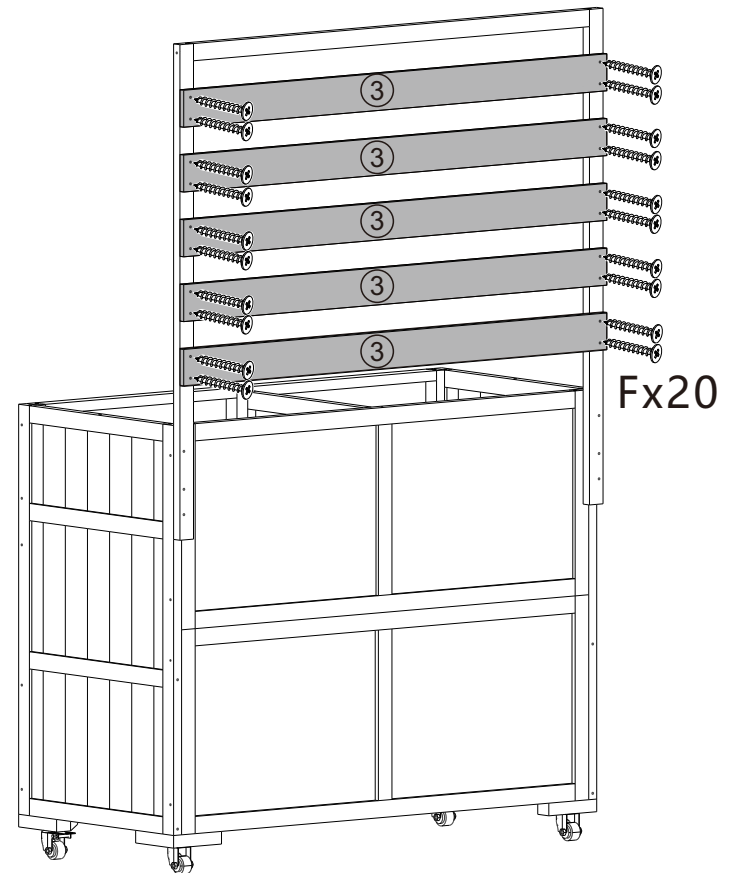

32

Fx20 ③ x5

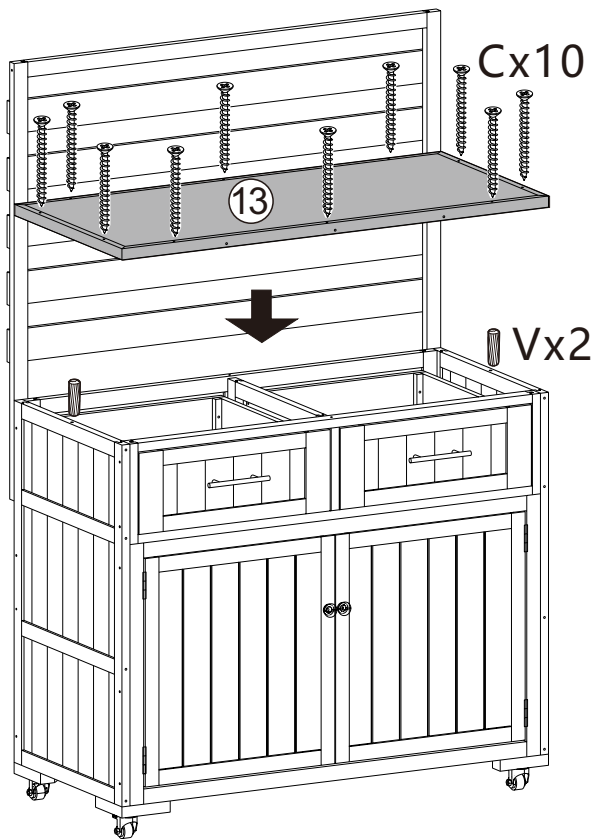

33

Cx10 Vx2 13 x1

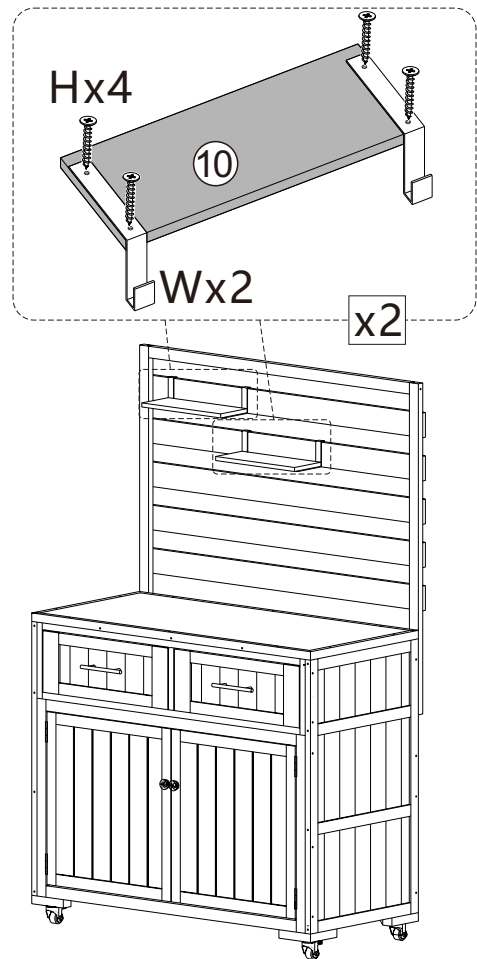

34

Wx4 Hx8 10 x2

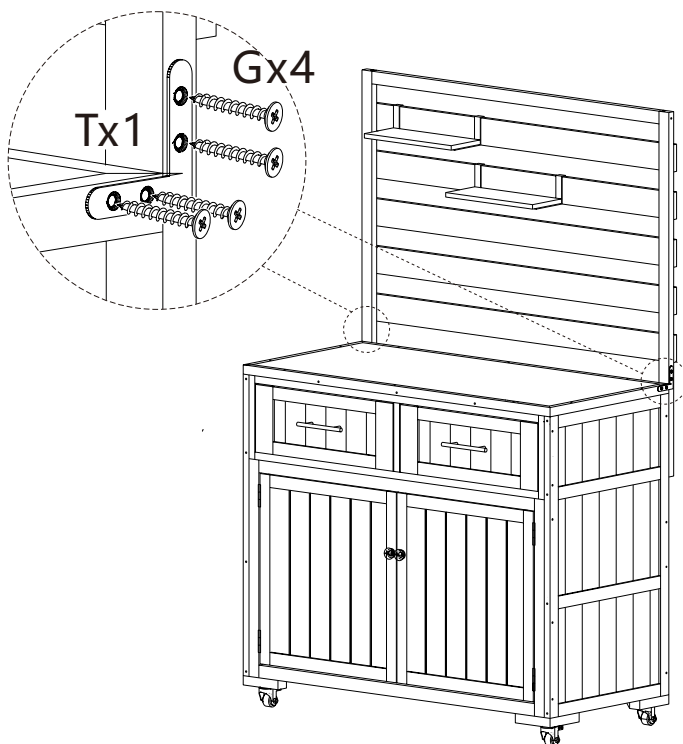

35

Gx8 Tx2

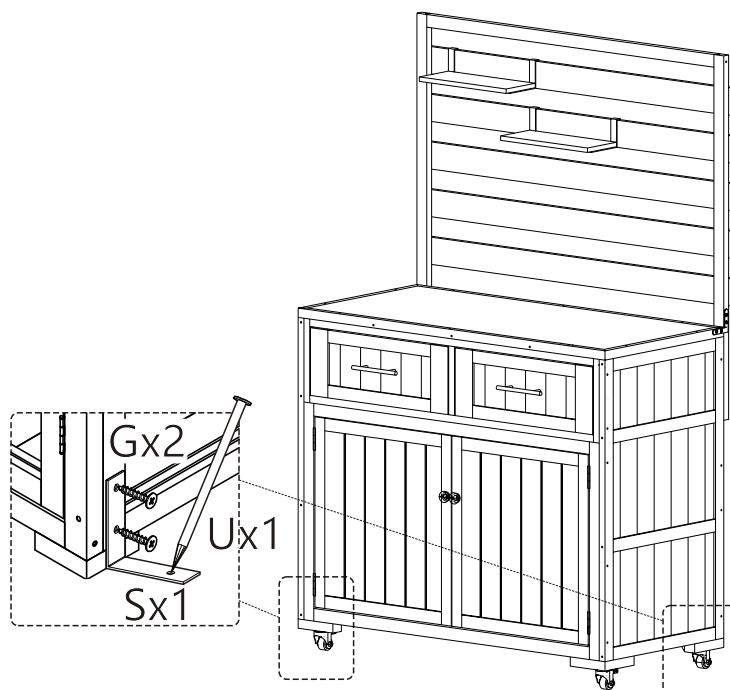

36

Gx4 Ux2 Sx2

Remove 4 wheels firstly, then assembly L shape metal and nails.
Retirez 4 roues tout d'abord, puis assemblage en forme de L métal et clous