

Cupboard
Armoire
Armario

IMPORTANT!-IMPORTANT!-IMPORTANTE!

Please provide Control No. to ensure replacement parts properly fit unit on hand.
 Fournir N° de contrôle pour assurer que les pièces de rechange s'adaptent correctement à l'unité en question.

Favor de proporcionar el numero de control para garantizar que las piezas de reemplazo ajuste correctame su producto.

Control No.
N° de contrôle
de control

 Name - Nom - Nombre

 Address - Adresse - Dirección

 City/State/Zip - Ville/Province/Code postal - Ciudad/Estado/Zona Postal

 Phone - Téléphone - Teléfono

 Email

"Check-list/Part Replacement request" - « Liste de contrôle/Demande de remplacement de pièce »

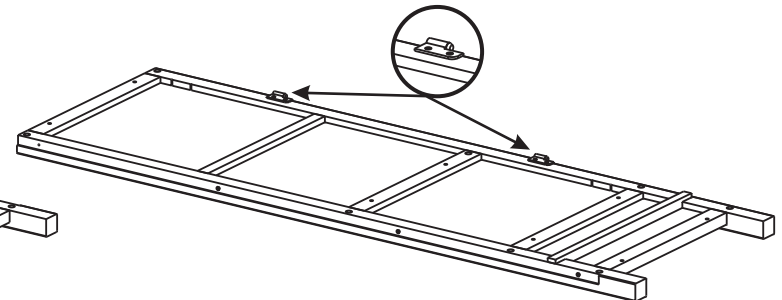
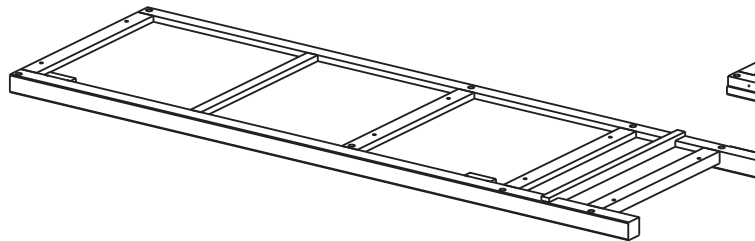
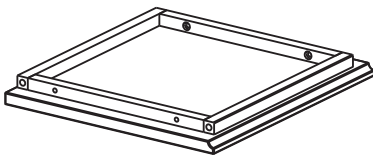

A	Top Panel Panneau supérieur Tapa		
Quantity Quantité Cantidad	1	Missing Manquant Ausente	

B	Left Panel Panneau gauche Panel izquierdo		
Quantity Quantité Cantidad	1	Missing Manquant Ausente	

C	Right Panel Panneau droit Panel derecho		
Quantity Quantité Cantidad	1	Missing Manquant Ausente	

IMPORTANT!-IMPORTANT!-IMPORTANTE!

Please provide Control No. to ensure replacement parts properly fit unit on hand.
 Fournir N° de contrôle pour assurer que les pièces de rechange s'adaptent correctement à l'unité en question.
 Favor de proporcionar el numero de control para garantizar que las piezas de reemplazo ajuste correctame su producto

Control No.
N° de contrôle
de control

Reason of replacement - Raison de remplacement
Razón del reemplazo:

 Name - Nom - Nombre

 Address - Adresse - Dirección

 Phone - Téléphone - Teléfono

 City/State/Zip - Ville/Province/Code postal - Ciudad/Estado/Zona Postal

 Email

"Check-list/Part Replacement request" - « Liste de contrôle/Demande de remplacement de pièce »

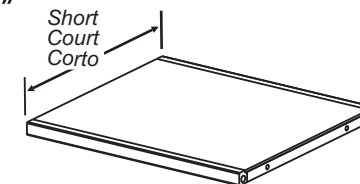
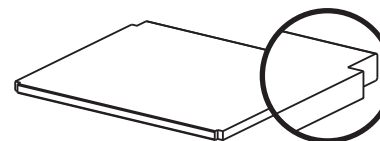
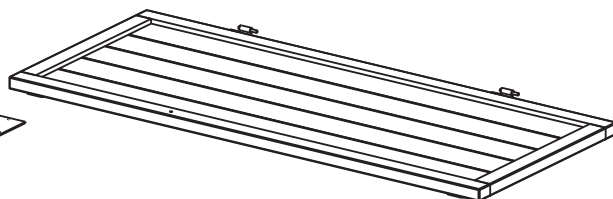
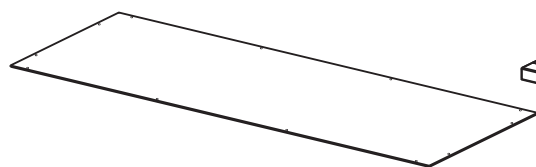

D	Back Panel Panneau arrière Panel trasero	Quantity Quantité Cantidad	1	Missing Manquant Ausente	
----------	--	----------------------------------	---	--------------------------------	--

E	Door Porte Puerta	Quantity Quantité Cantidad	1	Missing Manquant Ausente	
----------	-------------------------	----------------------------------	---	--------------------------------	--

F	Shelf Étagère Repisa	Quantity Quantité Cantidad	1	Missing Manquant Ausente	
----------	----------------------------	----------------------------------	---	--------------------------------	--

G	Inner Panel Panneau intérieure Panel interior	Quantity Quantité Cantidad	1	Missing Manquant Ausente	
----------	---	----------------------------------	---	--------------------------------	--

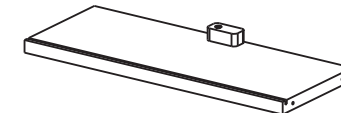
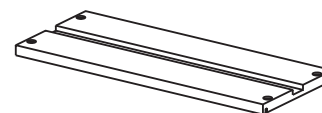
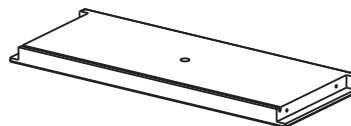
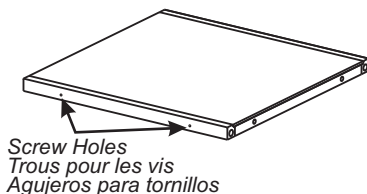
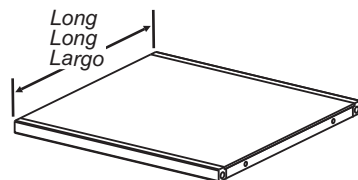

H	Middle Panel Panneau milieu Panel medio	Quantity Quantité Cantidad	1	Missing Manquant Ausente	
----------	---	----------------------------------	---	--------------------------------	--

I	Bottom Panel Panneau Inférieur Panel de abajo	Quantity Quantité Cantidad	1	Missing Manquant Ausente	
----------	---	----------------------------------	---	--------------------------------	--

J	Front Panel (Drawer) Panneau Avant (tiroir) Panel de enfrente (cajon)	Quantity Quantité Cantidad	1	Missing Manquant Ausente	
----------	--	----------------------------------	---	--------------------------------	--

K	Side Panel (Drawer) Panneau latéraux (tiroir) Panel Latéral (cajon)	Quantity Quantité Cantidad	2	Missing Manquant Ausente	
----------	--	----------------------------------	---	--------------------------------	--

L	Back Panel (Drawer) Panneau Arrière (tiroir) Panel de atrás (cajon)	Quantity Quantité Cantidad	1	Missing Manquant Ausente	
----------	--	----------------------------------	---	--------------------------------	--

IMPORTANT!-IMPORTANT!-IMPORTANTE!

Please provide Control No. to ensure replacement parts properly fit unit on hand.
 Fournir N° de contrôle pour assurer que les pièces de rechange s'adaptent correctement à l'unité en question.
 Favor de proporcionar el numero de control para garantizar que las piezas de reemplazo ajuste correctame su producto

Control No.
N° de contrôle
de control

Reason of replacement - Raison de remplacement
Razón del reemplazo:

 Name - Nom - Nombre

 Address - Adresse - Dirección

 Phone - Téléphone - Teléfono

 City/State/Zip - Ville/Province/Code postal - Ciudad/Estado/Zona Postal

 Email

"Check-list/Part Replacement request" - « Liste de contrôle/Demande de remplacement de pièce »

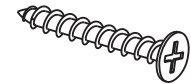
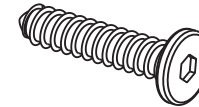
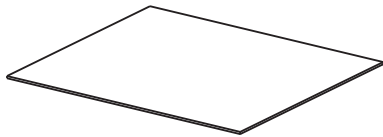

M	Bottom Board (Drawer) Conseil Inférieur (tiroir) Base de abajo (cajon)			
Quantity Quantité Cantidad	1	Missing Manquant Ausente		

N	Knob Bouton Perilla			
Quantity Quantité Cantidad	2	Missing Manquant Ausente		

O	Bolt* Cheville* Tornillo de metal*			
Quantity Quantité Cantidad	2	Missing Manquant Ausente		

P	Wood Screw Vis à bois Tornillo para madera			
Quantity Quantité Cantidad	16	Missing Manquant Ausente		

Q	Screw* (Phillips) Vis* (Phillips) Tornillo* (Phillips)			
Quantity Quantité Cantidad	8	Missing Manquant Ausente		

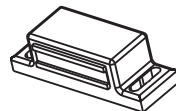

R	Small Screw* (Phillips) Petite vis* (Phillips) Tornillo Pequeño* (Phillips)			
Quantity Quantité Cantidad	16	Missing Manquant Ausente		

S	Magnet Latch Loquet à aimant Pasador Magnético			
Quantity Quantité Cantidad	2	Missing Manquant Ausente		

T	Wood Dowel Goujon en bois Clavija de madera			
Quantity Quantité Cantidad	16	Missing Manquant Ausente		

	Hex Wrench Clé Hexagonable Llave Hexagonal			
Quantity Quantité Cantidad	1	Missing Manquant Ausente		

* **Screw Driver is required and not included in the package.**
 * **Un tournevis est nécessaire mais n'est pas inclus avec cet ensemble.**
 * **Se requiere desarmador de cruz y no viene incluido.**

Assembly Instructions - Instructions d'assemblage - Instrucciones de ensamblaje

1

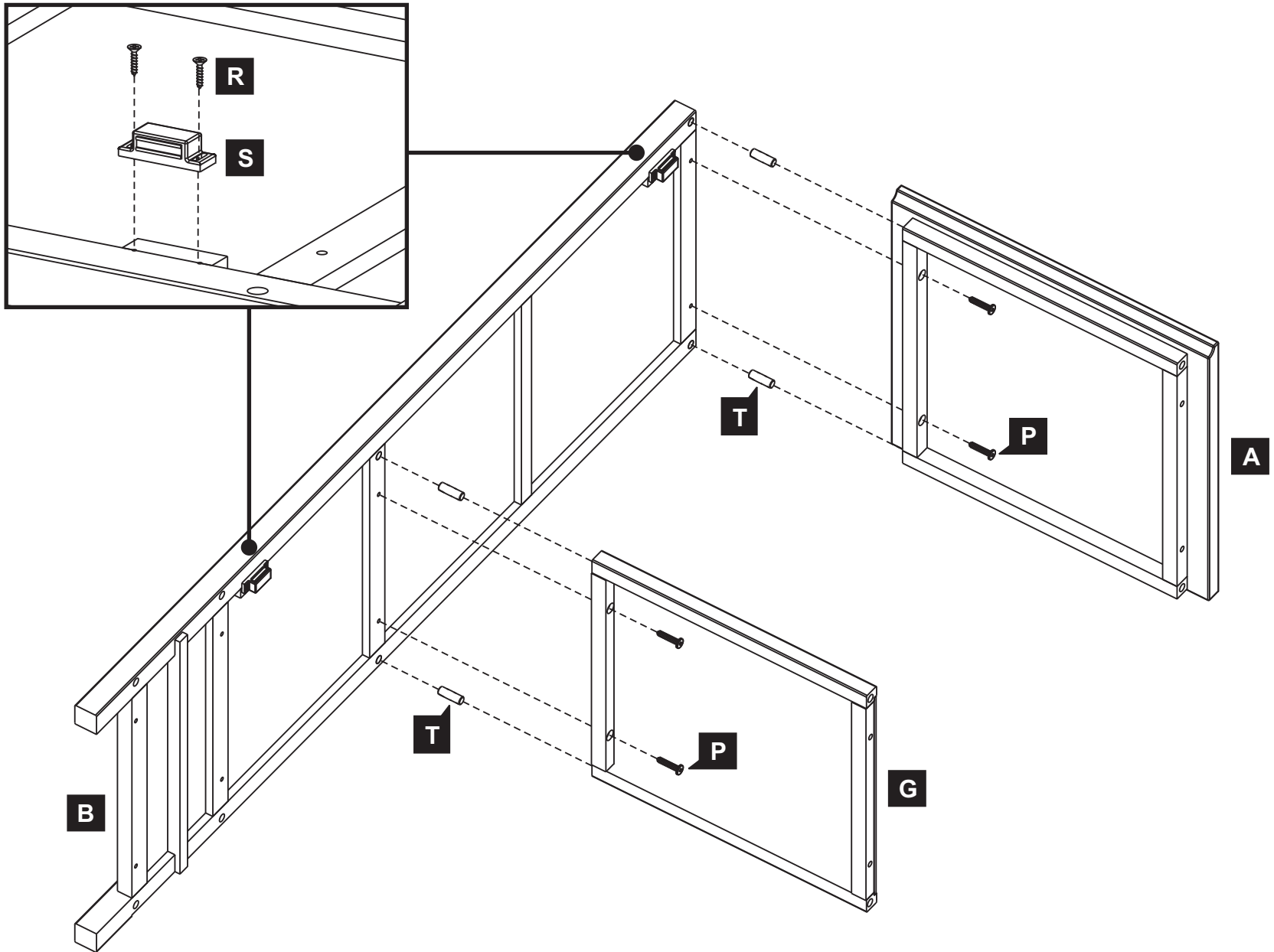

Assembly Instructions - Instructions d'assemblage - Instrucciones de ensamblaje

2

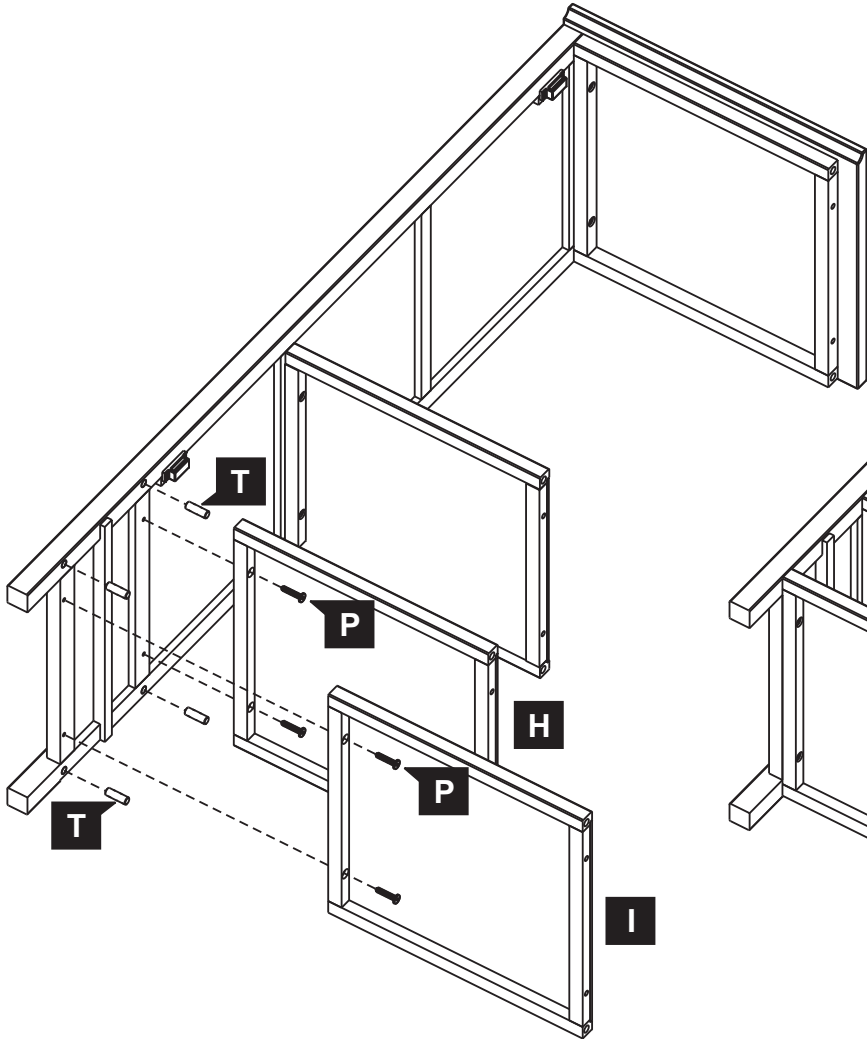

3

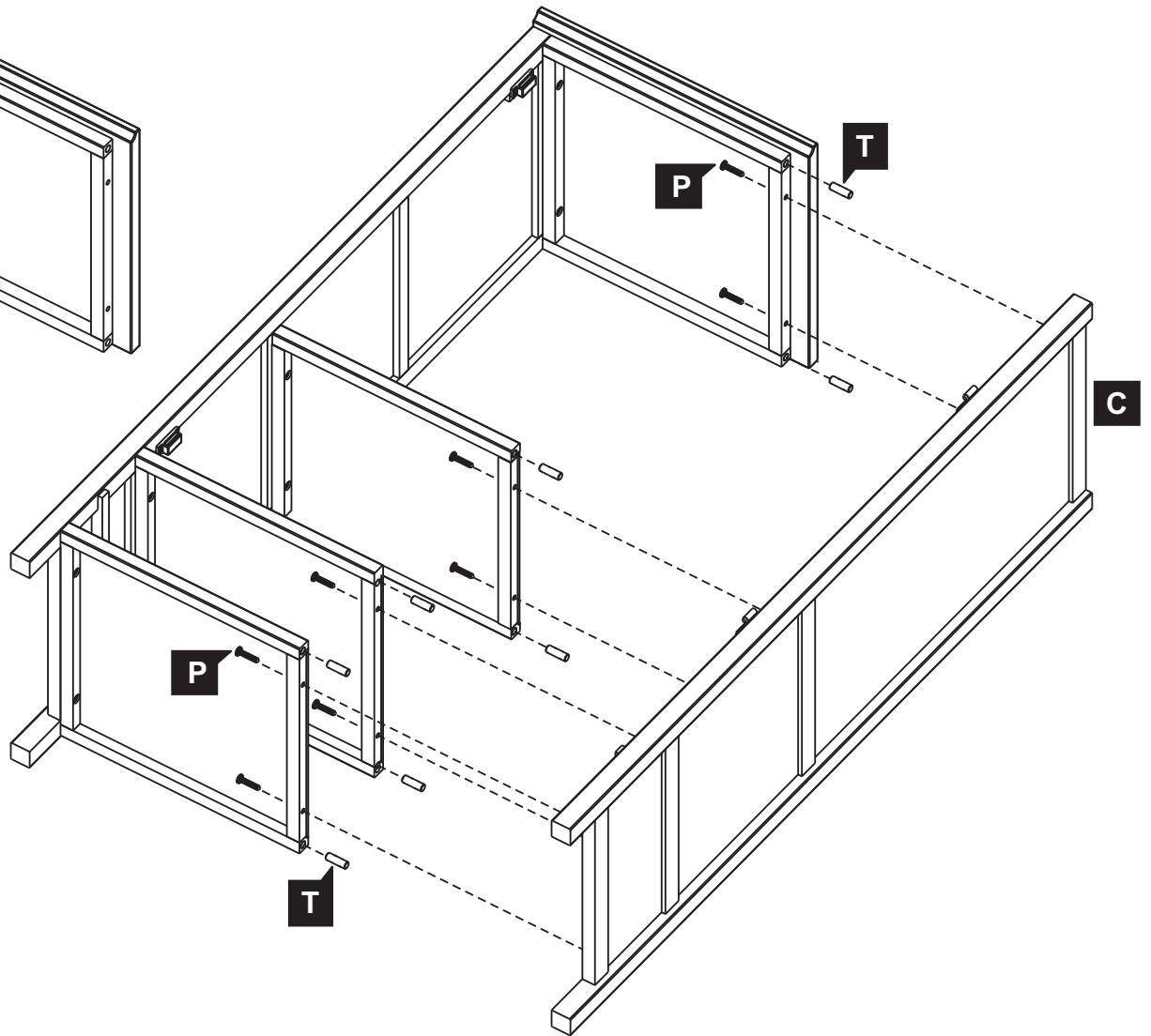

Assembly Instructions - Instructions d'assemblage - Instrucciones de ensamblaje

4

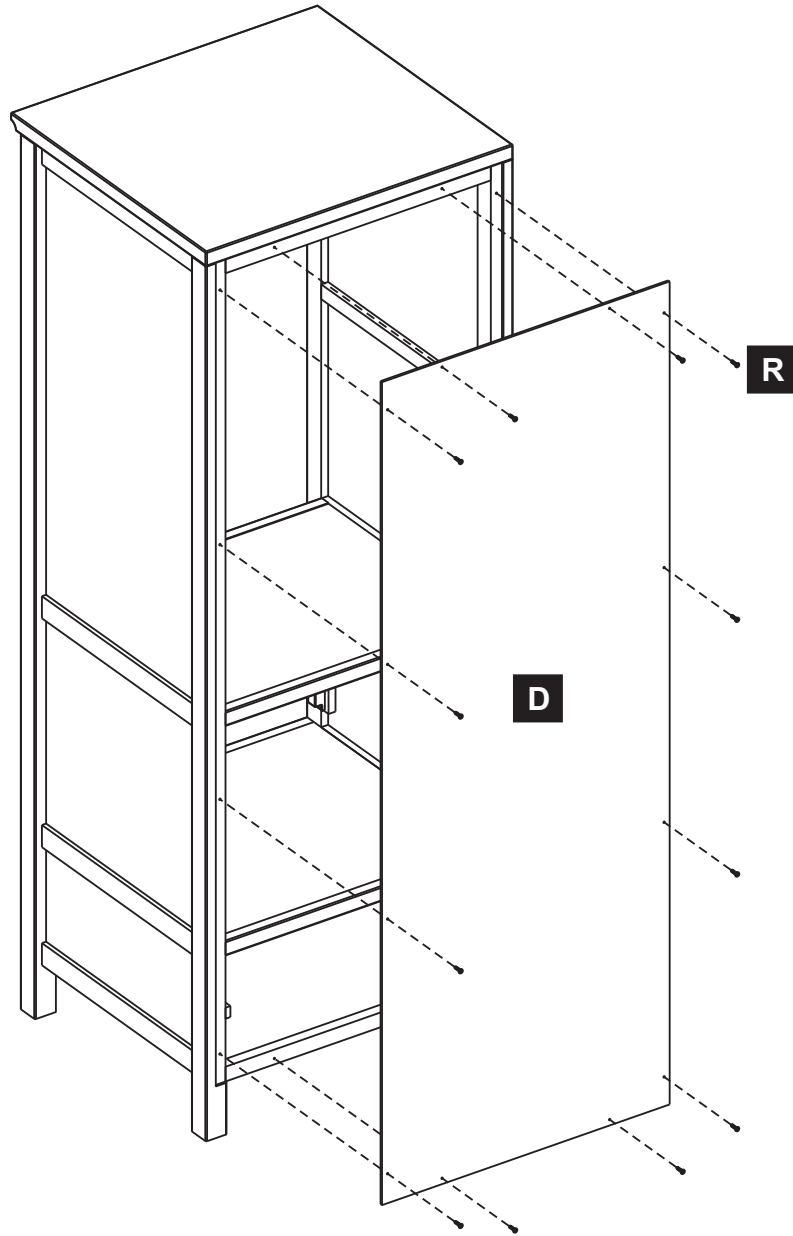

5

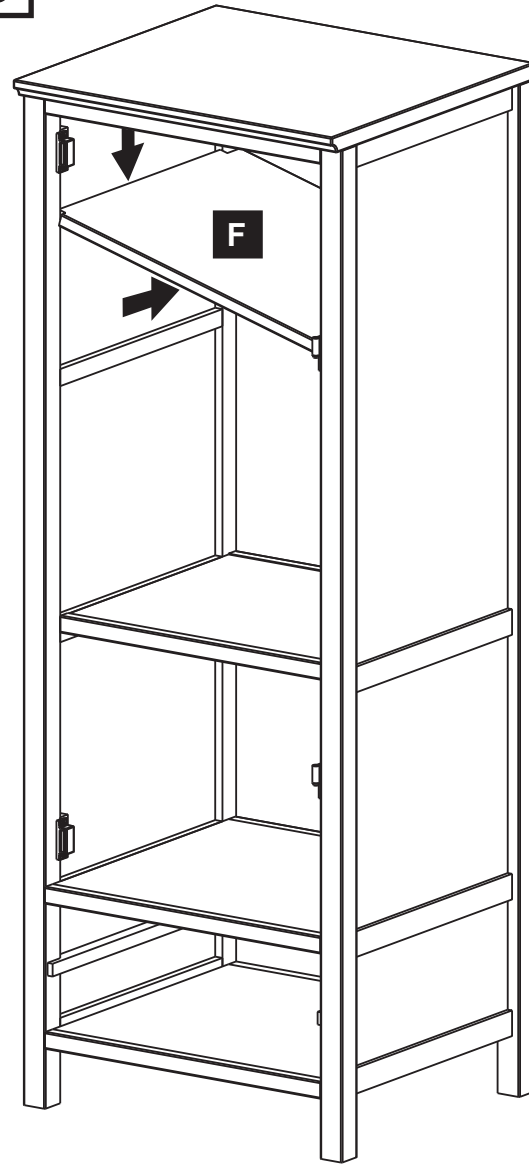

Assembly Instructions - Instructions d'assemblage - Instrucciones de ensamblaje

6 Drawer - Tiroir - Cajon

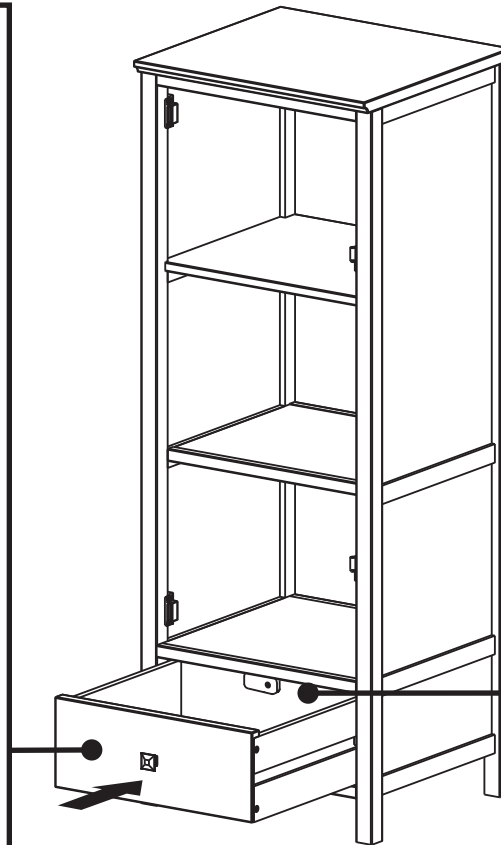
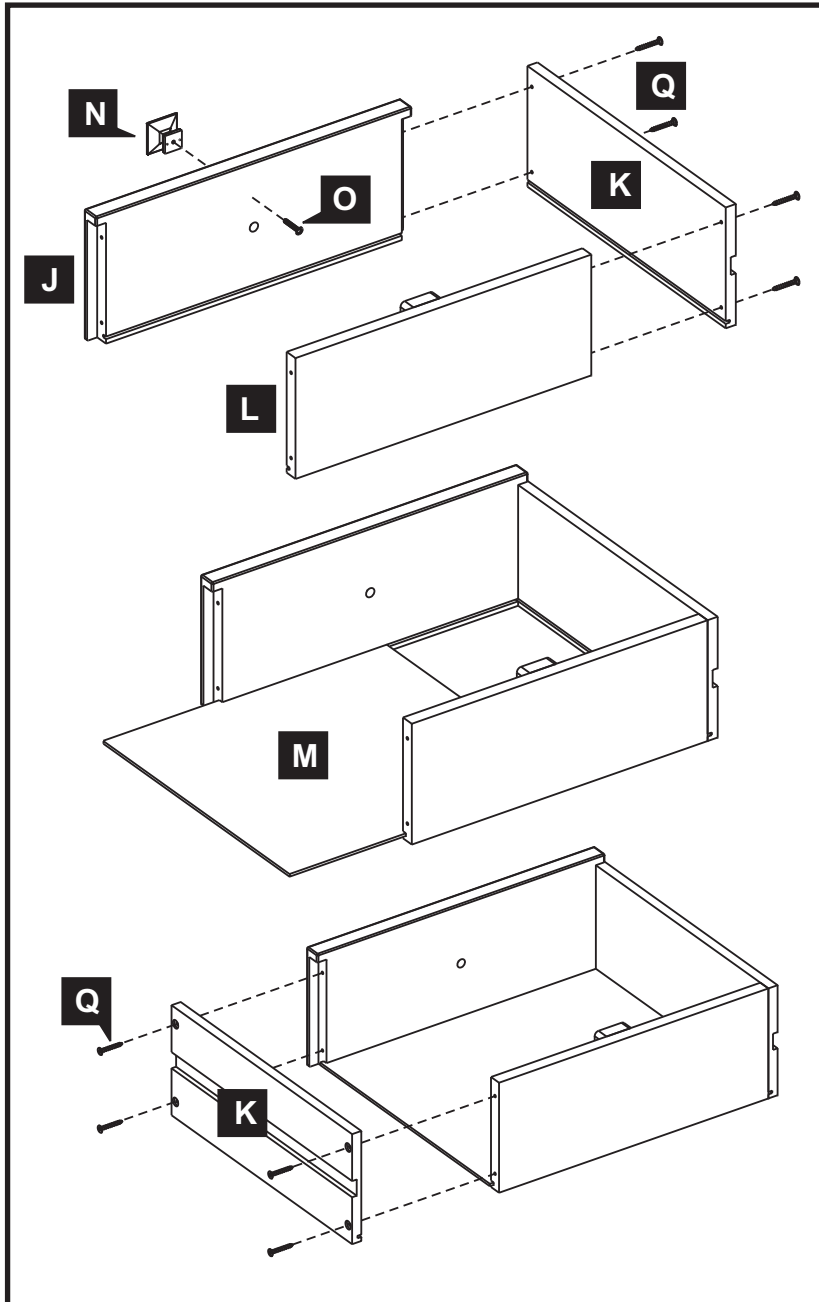

Flip Stopper UP to LOCK.
Tourner la butée vers le HAUT pour verrouiller.
volteé el pasador de madera para arriba para cerrar.

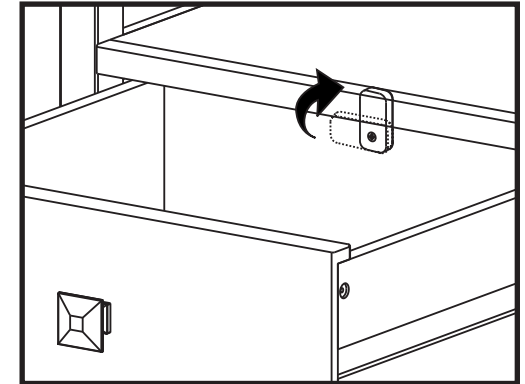

Care instructions: To clean, wipe with wet cloth and dry thoroughly. Use mild soap if necessary. Avoid use of commercial waxes or polishes or abrasive cleaning materials.

Instructions d'entretien: Pour nettoyer, essuyez avec un linge humide et séchez à fond. Utilisez un savon doux au besoin. Évitez d'utiliser des cires ou produits à polir de type commercial ou des matériaux de nettoyage abrasifs.

Instrucciones para el cuidado: Para limpiar, frótelo con algo húmedo y séquelo bien. Use un jabón suave si es necesario. Evite el uso de ceras o pulidores comerciales o materiales abrasivos.

Assembly Instructions - Instructions d'assemblage - Instrucciones de ensamblaje

7

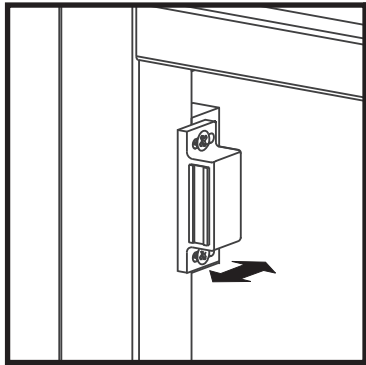

Tip!
Adjust position of magnet forward or backward as necessary to achieve proper contact with metal plates on the door.

Conseil!
Ajuster la position de l'aimant vers l'avant ou vers l'arrière selon les besoins afin d'obtenir un contact approprié avec les plaques métalliques situées sur les porte.

Consejo!
Ajuste la posición del imán para adelante o atrás como sea necesario para alcanzar el mejor contacto con las placas de metal en las puerta.

