



BOOKCASE HEADBOARD

ASSEMBLY INSTRUCTIONS

(TWIN, FULL)

Before assembling your bookcase Headboard, please read through these instructions carefully and familiarize yourself with the different parts. Please note that you will require a Phillips Head Screwdriver and an Allen wrench.

Phillips Head Screwdriver



Customer Supplied

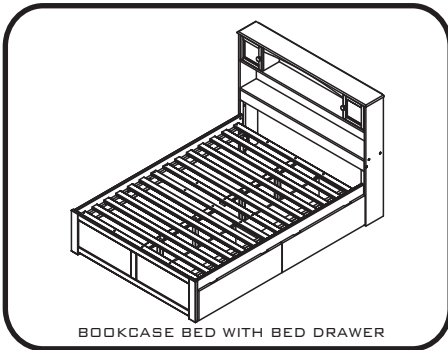

BOOKCASE BED WITH BED DRAWER

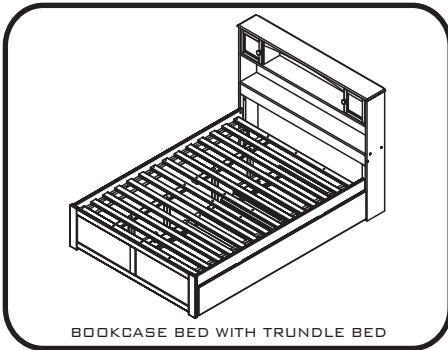

BOOKCASE BED WITH TRUNDLE BED

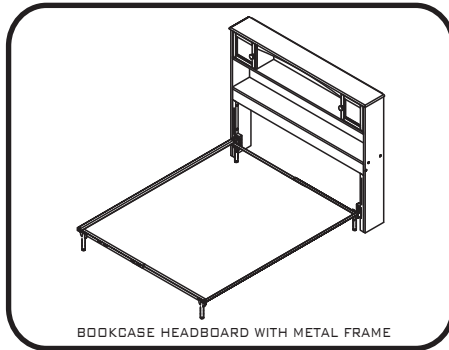

BOOKCASE HEADBOARD WITH METAL FRAME

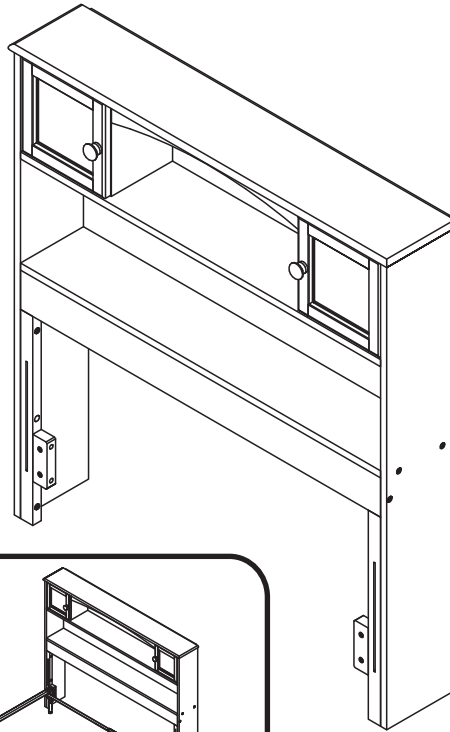

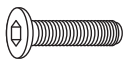

HEADBOARD HARDWARE

NOTE: WE INCLUDE SPARE HARDWARE IN CASE THE ALLEN WRENCH, JCB, WOODEN DOWEL, WASHER OR WOOD SCREW ARE DAMAGED DURING ASSEMBLY.

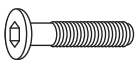
- A**  JCB M6 X 1 2/8"(30mm) - 4 pcs
Spare - 1 pc

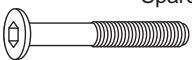
- B**  JCB M6 X 1 1/2"(35mm) - 6 pcs
Spare - 1 pc

- C**  JCB M6 X 2"(50mm) - 4 pcs
Spare - 1 pc

- D**  WOODEN DOWEL 10 X 30mm - 4 pcs
Spare - 1 pc

- E**  WOODEN DOWEL 8 X 30mm - 12 pcs
Spare - 1 pc

- F**  METAL L-BRACKET - 3 pcs

- G**  WOOD SCREW 1/2" - 6 pcs
Spare - 1 pc

- H**  WOOD SCREW 1 1/2" - 4 pcs
Spare - 1 pc

- I**  WOODEN PULL - 2 pcs

- J**  WOODEN PULL SCREW - 2 pcs

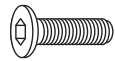
- K**  JCB M6 X 1"(25mm) - 6 pcs
Spare - 1 pc

- L**  SPLIT WASHER - 4 pcs
Spare - 1 pc

- M**  FLAT WASHER - 4 pcs
Spare - 1 pc

- N**  ALLEN WRENCH - 1 pc
Spare - 1 pc

HEADBOARD PARTS LIST

- | | | |
|-----------|-------------------------|--------------|
| 01 | HARDWARE | 1 BOX |
| 02 | TOP STORAGE | 1 SET |
| 03 | LEFT SIDE PANEL | 1 PC |
| 04 | RIGHT SIDE PANEL | 1 PC |
| 05 | LOWER SHELF | 1 PC |
| 06 | PILLOW STOP | 1 PC |
| 07 | BACK PANEL | 1 PC |
| 08 | LEFT POST | 1 PC |
| 09 | RIGHT POST | 1 PC |
| 10 | SPACER BLOCK | 2 PCS |

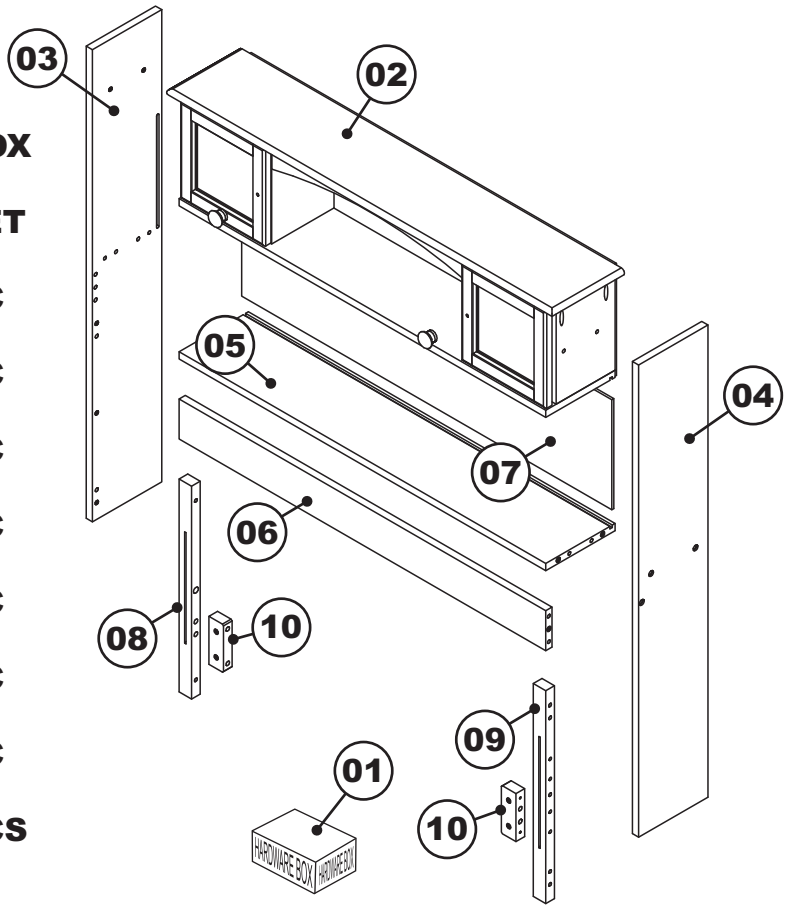

STEP 1

Insert wooden dowel to locator holes will receive (D)(E) as shown below.

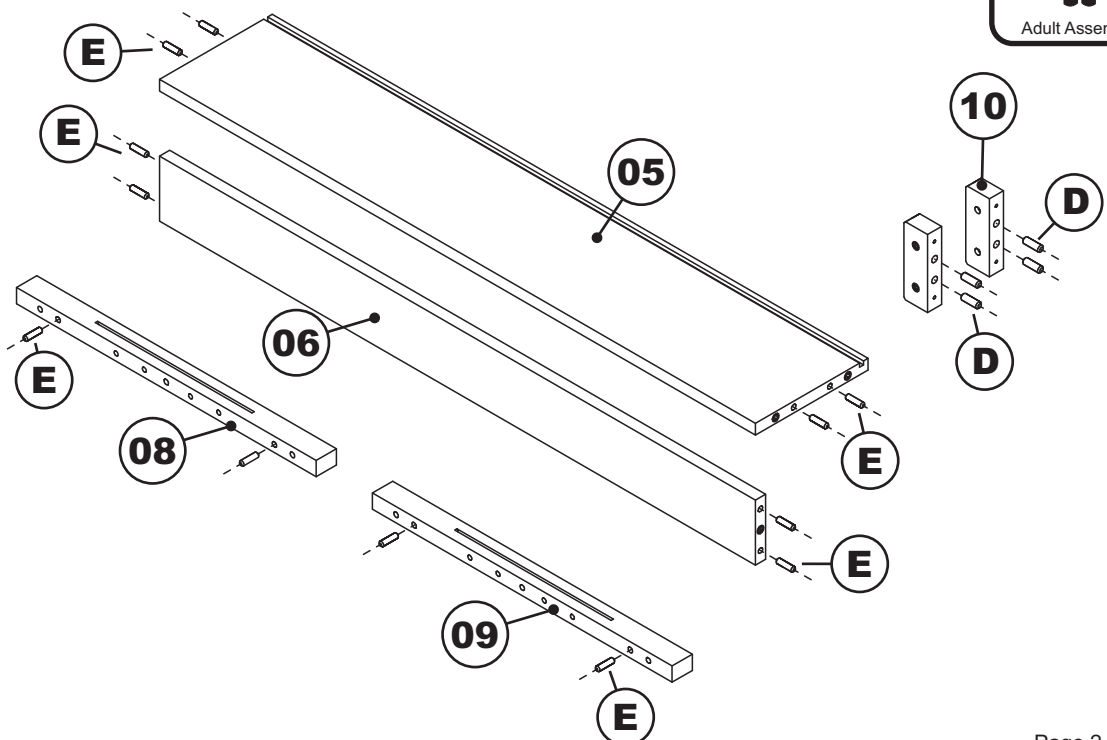
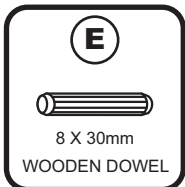
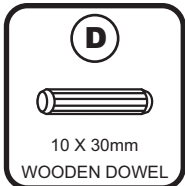

STEP 2

Attach the left, right post (08) and (09) to the left, right side panel (03) and (04) as shown below. Using JCB (C) and (K). Tighten with allen wrench (N).

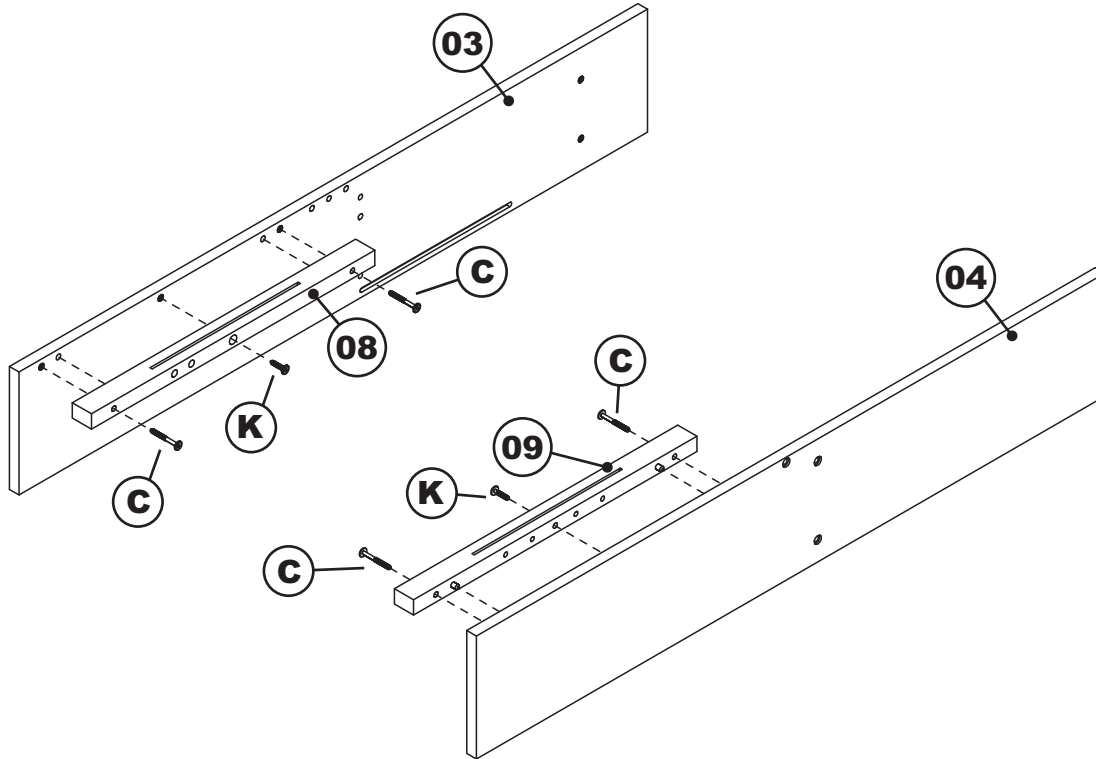

Adult Assembly

C

JCB M6 X 2"

K

JCB M6 X 1"

N

ALLEN WRENCH

STEP 3

Attach the lower shelf (05), pillow stop (06) & back panel (07) to side panels (03) and (04) as shown below. Using JCB (B), tighten with Allen wrench (N).

Attach the spacer block (10) to side panels (03) and (04) as shown below.

Using wood screw (H), tighten with Phillips head screwdriver. (Customer Supplied)

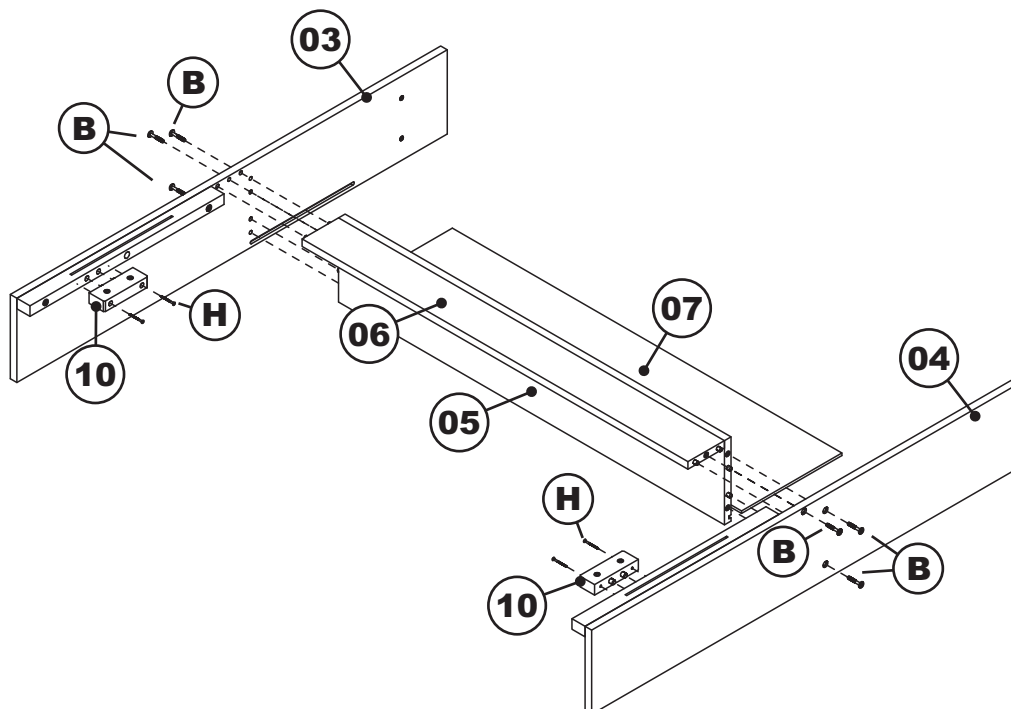

Adult Assembly

B

JCB M6 X 1 1/2"

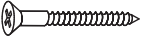
H

WOOD SCREW

N

ALLEN WRENCH

STEP 4

Lay the top storage (02) on the floor upside down, taking care to lay it on some cardboard to prevent scratching. Stand the side panel assembly upside down and using JCB (A), tighten with Allen wrench (N).

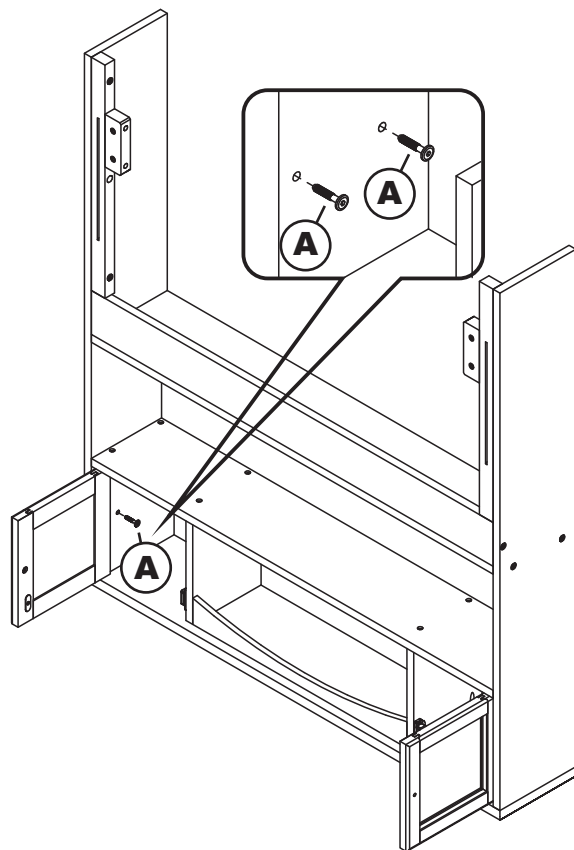
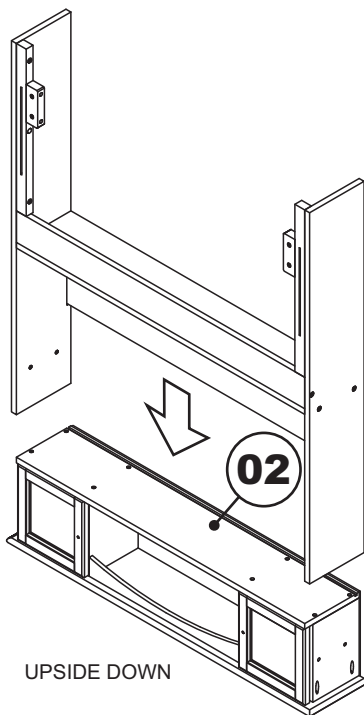
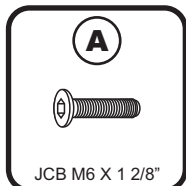

STEP 5

Install metal L- Bracket (F) as shown below. Using wood screw (G), tighten with Phillips head screwdriver. (Customer supplied)

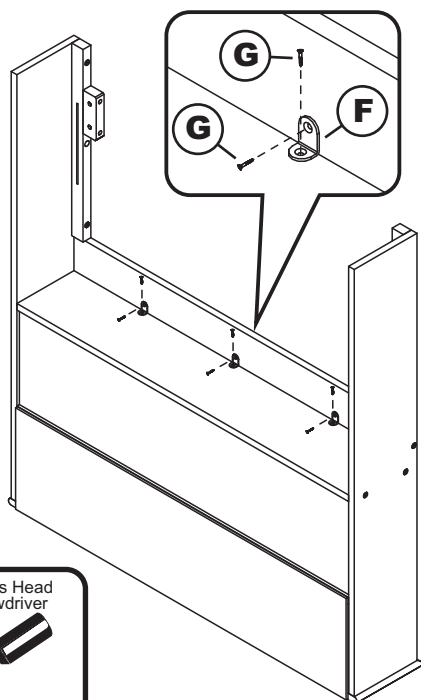
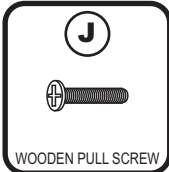
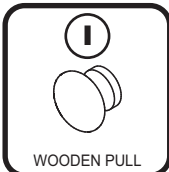
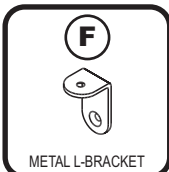

STEP 6

Install wooden pull (I) to each of the doors as shown. Using wooden pull screws (J), tighten with Phillips head screwdriver.

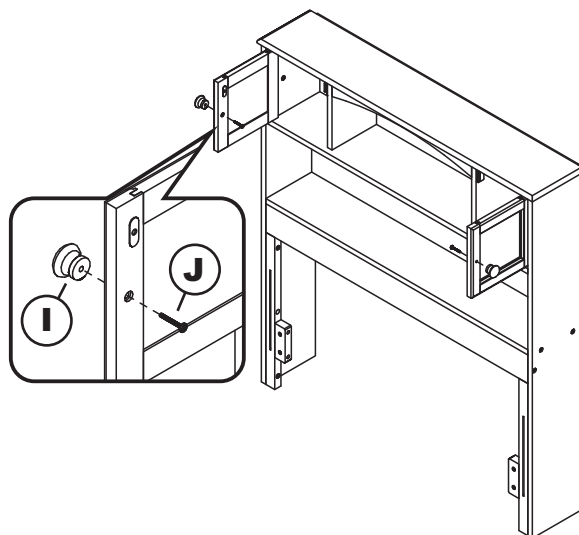

Your Bookcase Headboard is now ready for use.

STEP 7

Attach headboard assembly to the bed frame as shown below. (Purchased separately)
Using bed hook or Install the Headboard to the metal frame (Purchased separately).
Using JCB (K) split and flat washer (L) and (M) tighten with allen wrench (N).

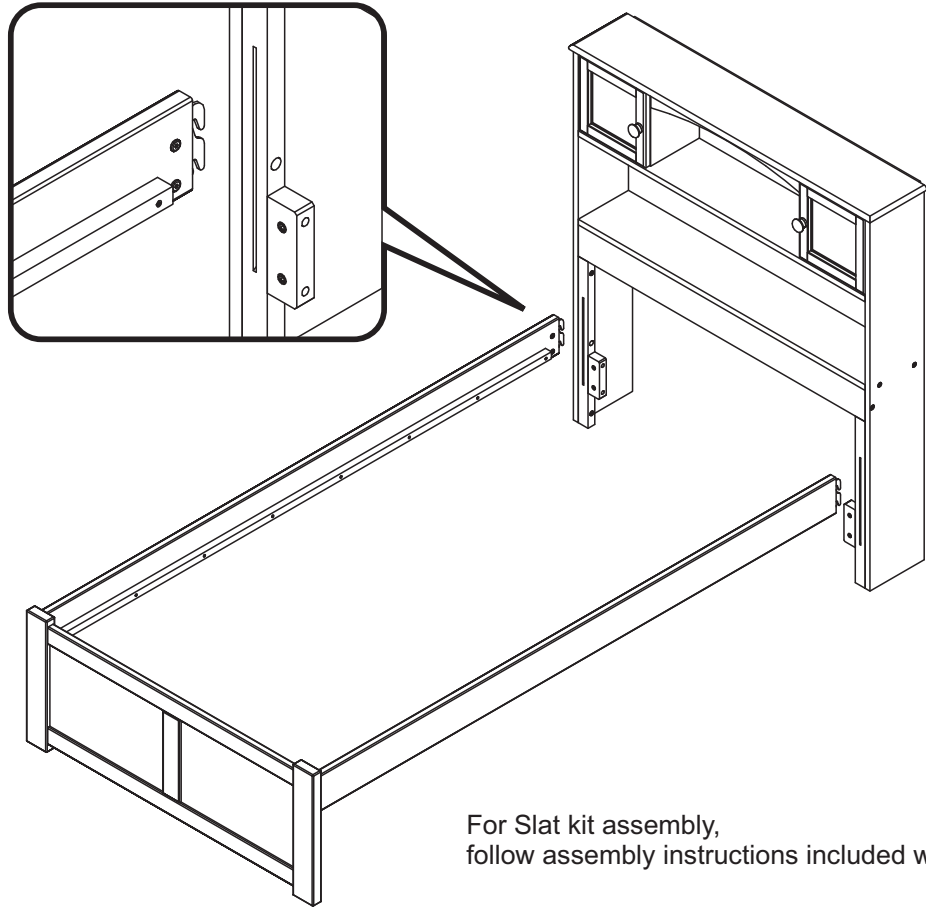

For Slat kit assembly,
follow assembly instructions included with slat kit.

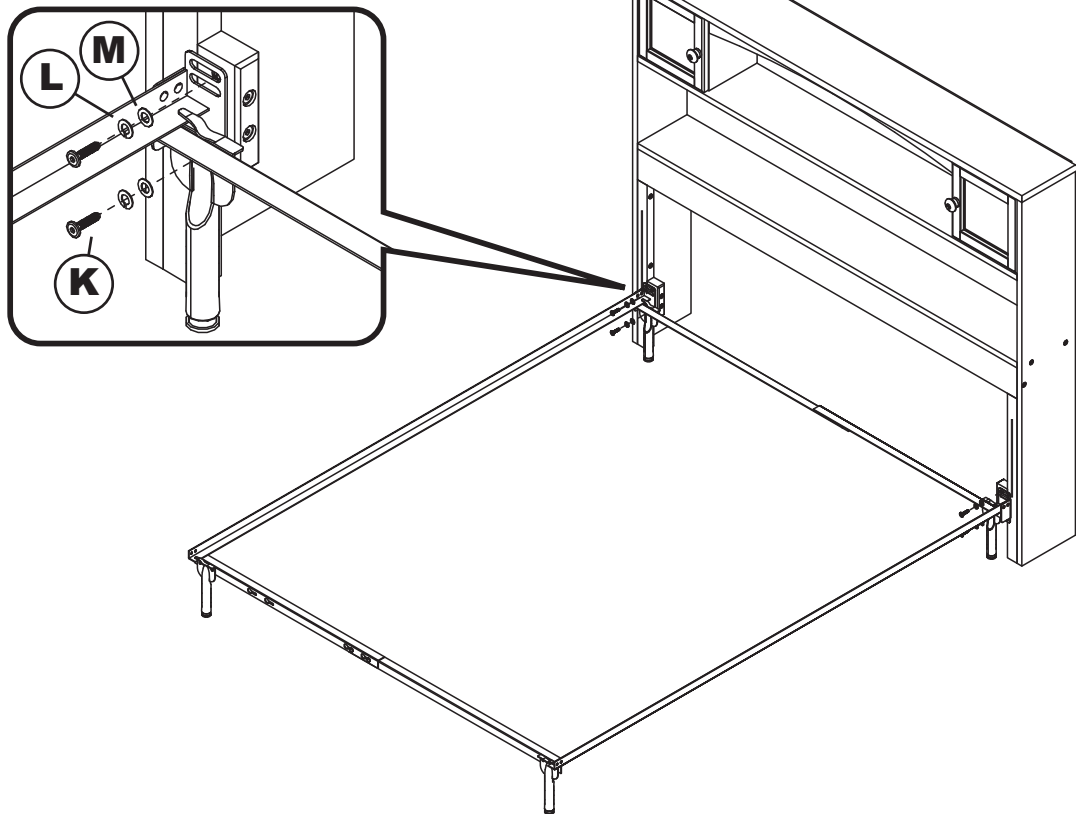

Adult Assembly

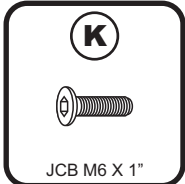

JCB M6 X 1"



SPLIT WASHER

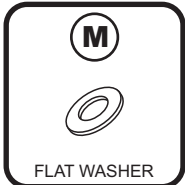

FLAT WASHER



ALLEN WRENCH

Congratulations!

Your Bookcase Bed is now ready for use.

To ensure lasting safety, we recommend that you periodically check that all screws are tight and all parts are secure.