

Installation & Assembly

Dimensions

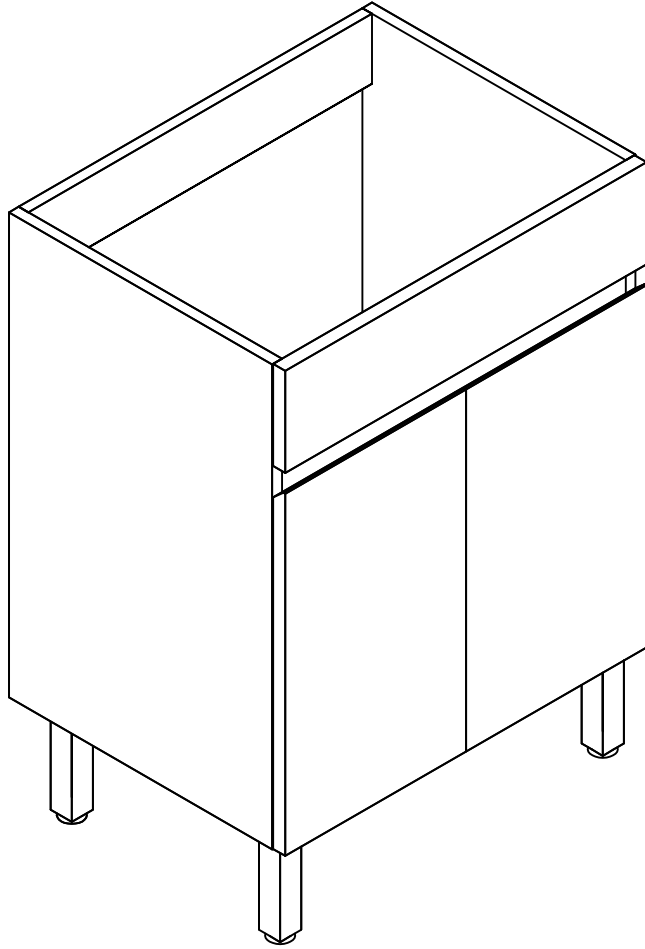

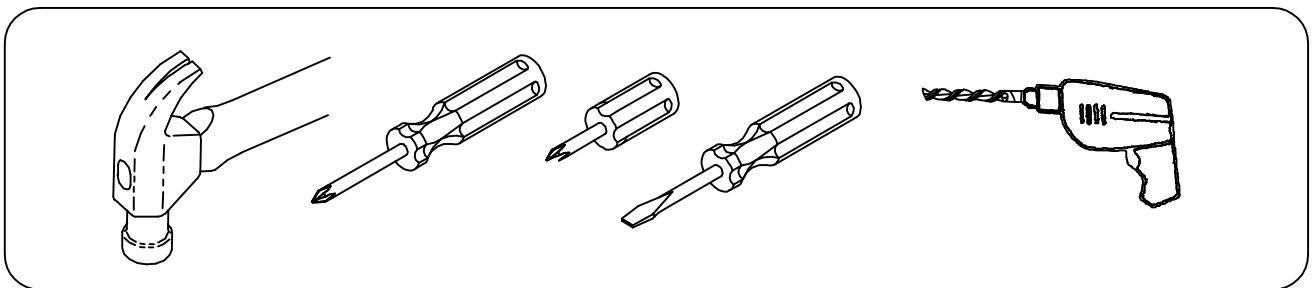





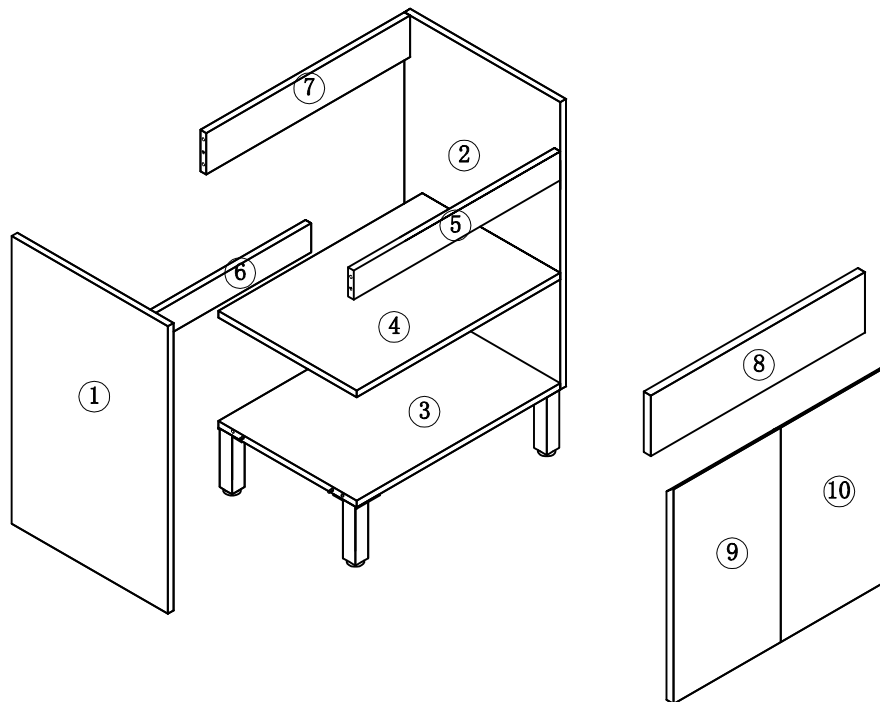











YOU MAY NEED (NOT SUPPLY)





ASSEMBLY DIAGRAM



PARTS LIST					
PARTS LIST					
NO	DESCRIPTION	QTY	NO	DESCRIPTION	QTY
①	Left side panel 	1	⑧	Front plate 	1
②	Right side panel 	1	⑨	Left door panel 	1
③	Bottom panel 	1	⑩	Right door panel 	1
④	Active laminate 	1			
⑤	Front fender 	1			
⑥	Rear baffle 	1			
⑦	Rear baffle 	1			

PARTS LIST					
HARDWARE LIST					
NO	DESCRIPTION	QTY	NO	DESCRIPTION	QTY
A	Three-in-one eccentric wheel 	16	G	Two-in-one screws 	4
B	Three-in-one connecting rod 	16	H	4*16mm screw 	36
C	Three-in-one sticker 	16	I	Aluminum alloy leg 	4
D	8*40mm wood dowel pins 	10			
E	Two-in-one lock handle 	4			
F	Door hinges 	4			
<p>CAUTION: Please confirm the parts list before installation</p>					

STEP 1

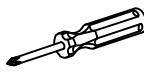
HARDWARE LIST		
Two-in-one screws G  4PCS	Three-in-one connecting rod B  16PCS	

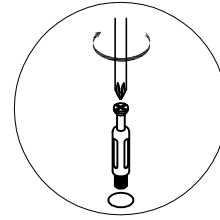

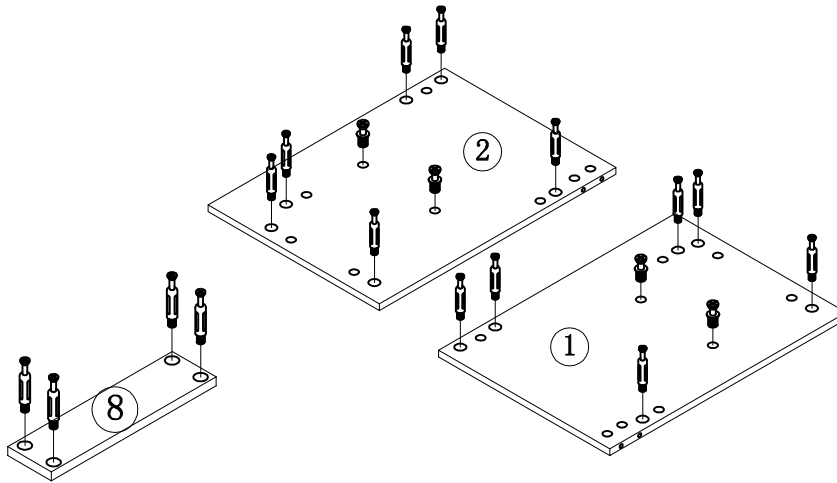

Put the three-in-one connecting rod in the $\Phi 10\text{mm}$ hole of the following panels and tighten them with a cross screwdriver or an electric tool.

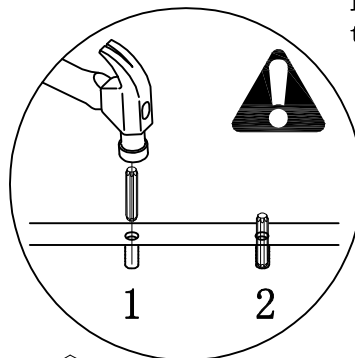
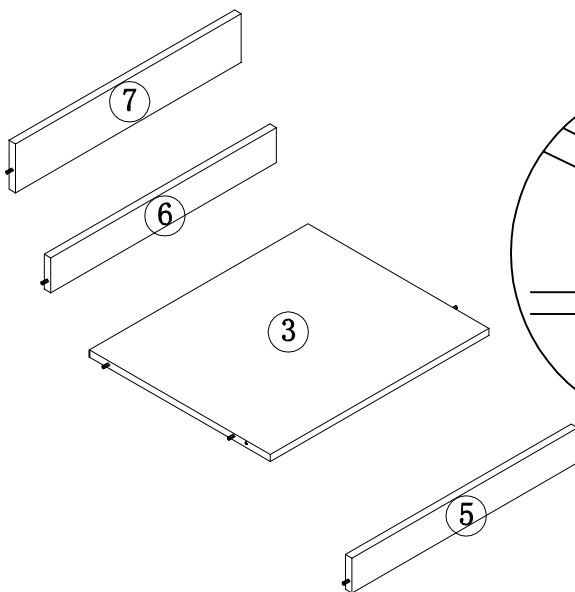

STEP 2

1.Strike the $\Phi 08*40\text{mm}$ wood dowel pin into the $\Phi 8\text{m}$ hole of the above panels with an iron hammer. Please note that the hole of the three-in-one connecting rod should also be 8mm. The hole of the three-in-one connecting rod connects to the hole of $\Phi 15\text{mm}$ three-in-one eccentric wheel.



HARDWARE LIST	
8*40mm wood dowel pins D  10PCS	

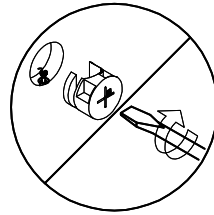
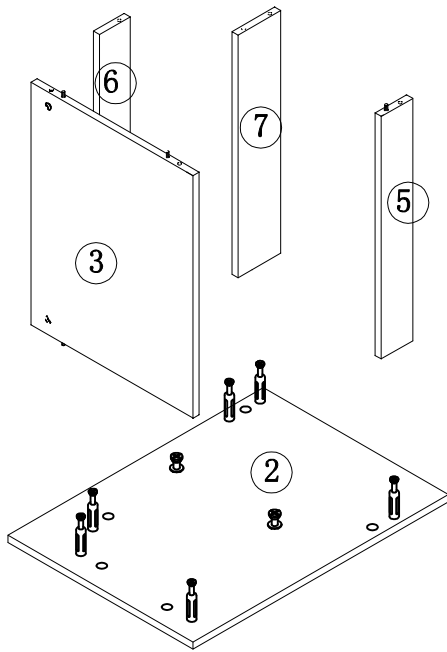

STEP 3

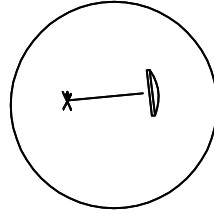

Connect No.3-5-6-7 panel to No. 2 panel tightly with the three-in-one eccentric wheel. i



2.Cover the hole where the eccentric wheel is put with the three-in-one sticker.

HARDWARE LIST		
Three-in-one eccentric wheel A  6PCS	Three-in-one sticker C  6PCS	

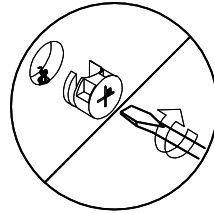
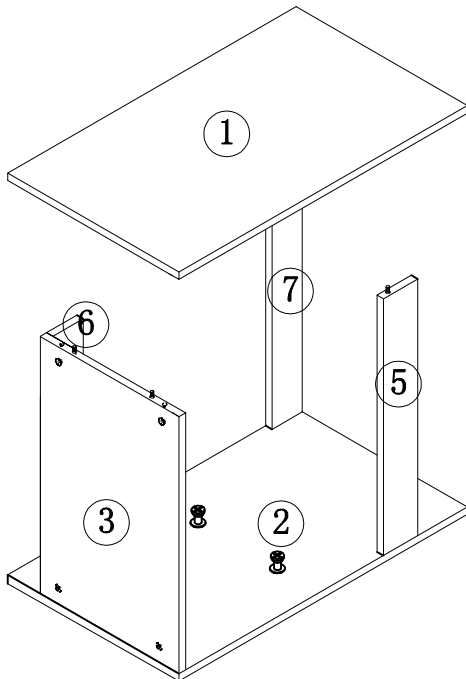

STEP 4

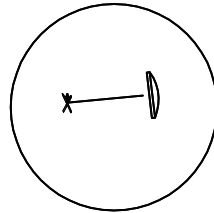

1.Connect No. 1 panel to No.3-5-6-7 panel tightly with the three-in-one eccentric wheel.





2.Cover the mounting hole of the eccentric wheel with a three-in-one sticker.

HARDWARE LIST		
Three-in-one eccentric wheel A  6PCS	Three-in-one sticker C  6PCS	

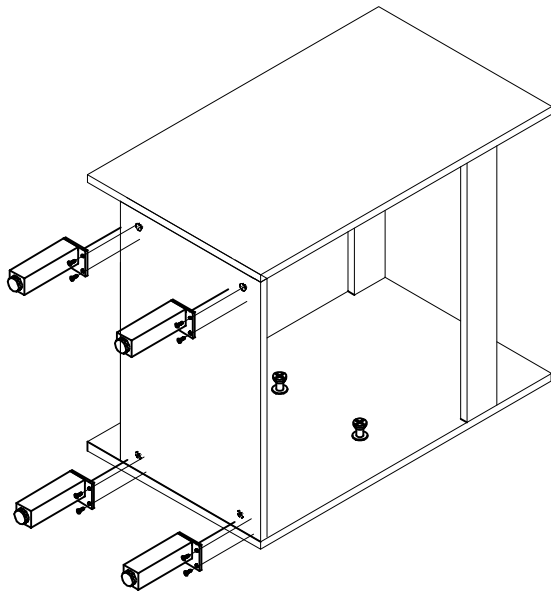
STEP 5

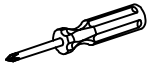

1. Fix feet of the cabinet with 4*16mm screws.

HARDWARE LIST		
4*16mm screw	Aluminum alloy leg	
H  12PCS	I  4PCS	

STEP 6

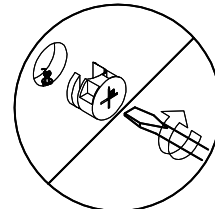
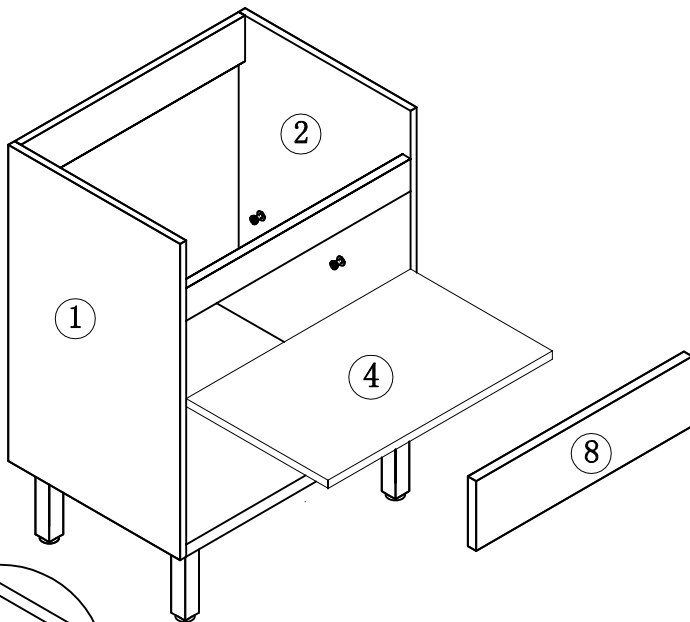

Connect No. 8 panel to No. 1-2 panel tightly with the three-in-one eccentric wheel.

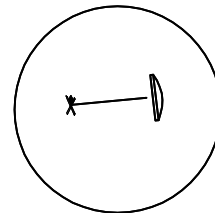



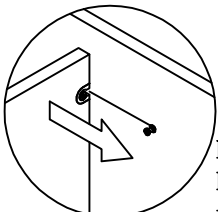

Cover the mounting hole of the eccentric wheel with a three-in-one sticker.

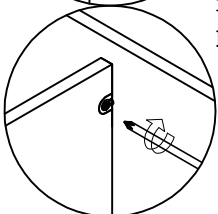

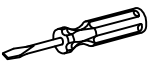
Fix the two-in-one lock handle on No. 4 plate and put it in the cabinet. Put the pipe plug on No. 4 plate



HARDWARE LIST			
Two-in-one lock handle	Three-in-one eccentric wheel	Three-in-one sticker	
E  4PCS	A  4PCS	C  4PCS	

STEP 7

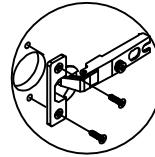
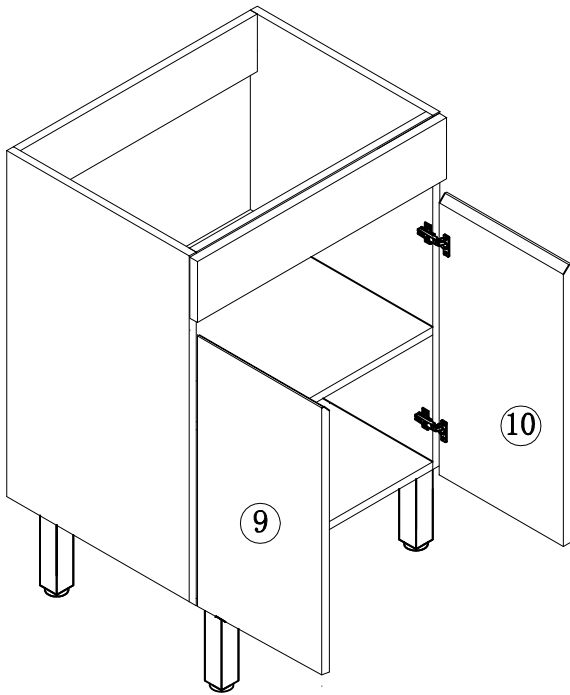

1. Install the hinge cup to the door panel with 4*16mm screws.

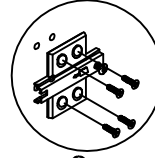

2. Install the hinge to the side panel with 4*16mm screws.

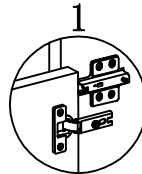

3. Install the hinge cup on the door panel to the hinge of the side panel.

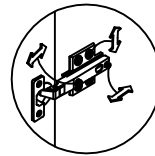

4. Adjust the door panel clearance.

HARDWARE LIST		
4*16mm screw	Door hinges	
H  24PCS	F  4PCS	

Hinge/Door Adjustment and Realignment

• If adjustment or realignment is needed, follow the instructions provided in the following chart.

Vertical adjustment

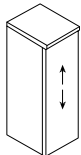

1. Loosen screws

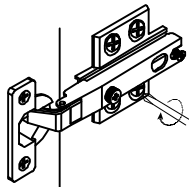

2. Adjust hinge

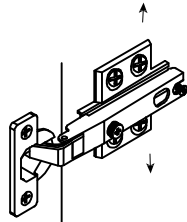

3. Tighten screws

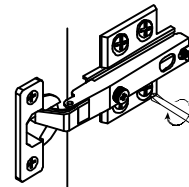

Horizontal adjustment

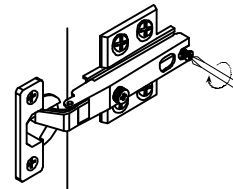
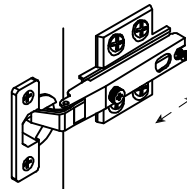
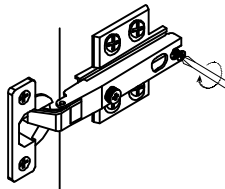
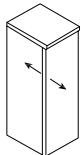

Door gap adjustment

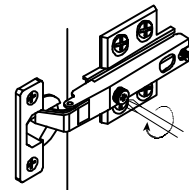
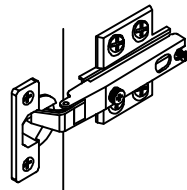
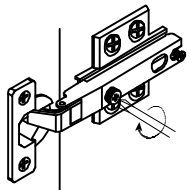
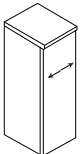

STEP 8

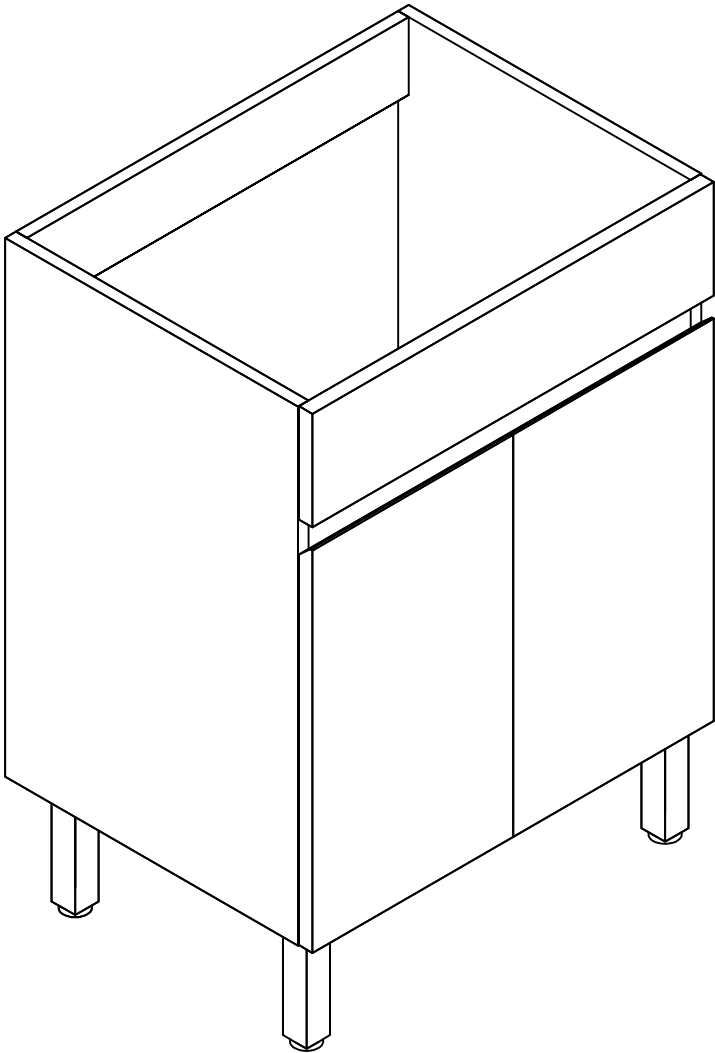



Choking hazard-Small Parts : This unit contains small parts, not for children under 3 years.

Tip-over hazard : Secure finished unit to wall stud using L-Bracket and wall screw (#10*1.5"W/out provided). If a wall stud is not neccessible , Consault your local hardware store for appropriate mounting hardware . Failure to properly install will result in product collapse or tip-over. Serious injury can occur .