

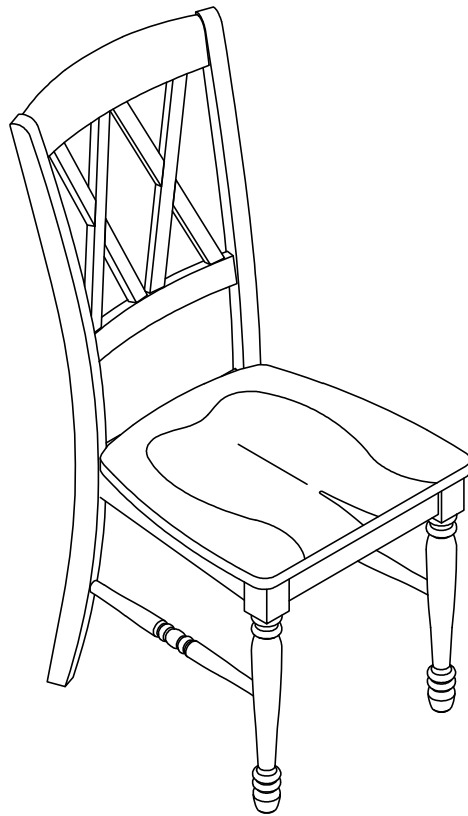

Dining Chair

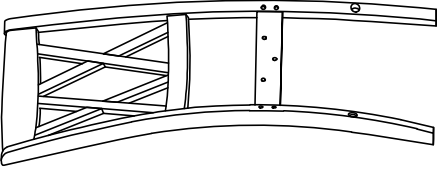
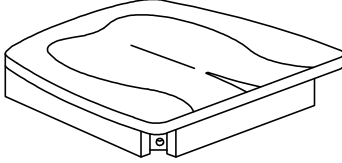
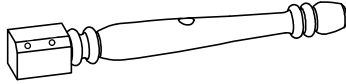
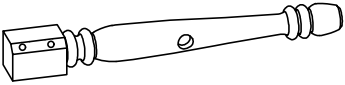
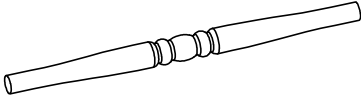

PART LIST

<p>A</p> 	<p>B</p> 	<p>C</p> 
<p>Chair Back 2 PCS</p>	<p>Seat Frame 2 PCS</p>	<p>Left Front Leg 2 PCS</p>
<p>D</p> 	<p>E</p> 	
<p>Right Front Leg 2 PCS</p>	<p>Side Stretcher 4 PCS</p>	

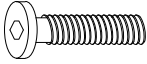
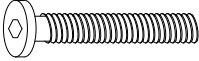
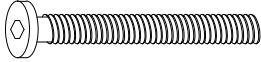
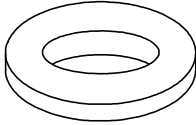
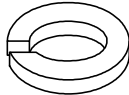
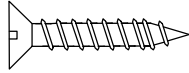
HARDWARE LIST

<p>#1</p>  <p>M6 x 40mm</p>	<p>#2</p>  <p>M6 x 50mm</p>	<p>#3</p>  <p>M6 x 80mm</p>
<p>Short Bolt 6 PCS (Extra 2)</p>	<p>Bolt 8 PCS (Extra 2)</p>	<p>Long Bolt 8 PCS (Extra 2)</p>
<p>#4</p>  <p>1/4"</p>	<p>#5</p>  <p>1/4"</p>	<p>#6</p>  <p>M4 x 38mm</p>
<p>Flat Washer 22 PCS (Extra 2)</p>	<p>Spring Washer 22 PCS (Extra 2)</p>	<p>Screw 8 PCS (Extra 2)</p>
<p>#7</p>  <p>M4 Allen Wrench 1 PC</p>		

ADDITIONAL TOOLS (Not Provided)



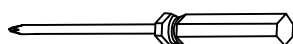

Note: It is not recommended to use power tools during assembly.

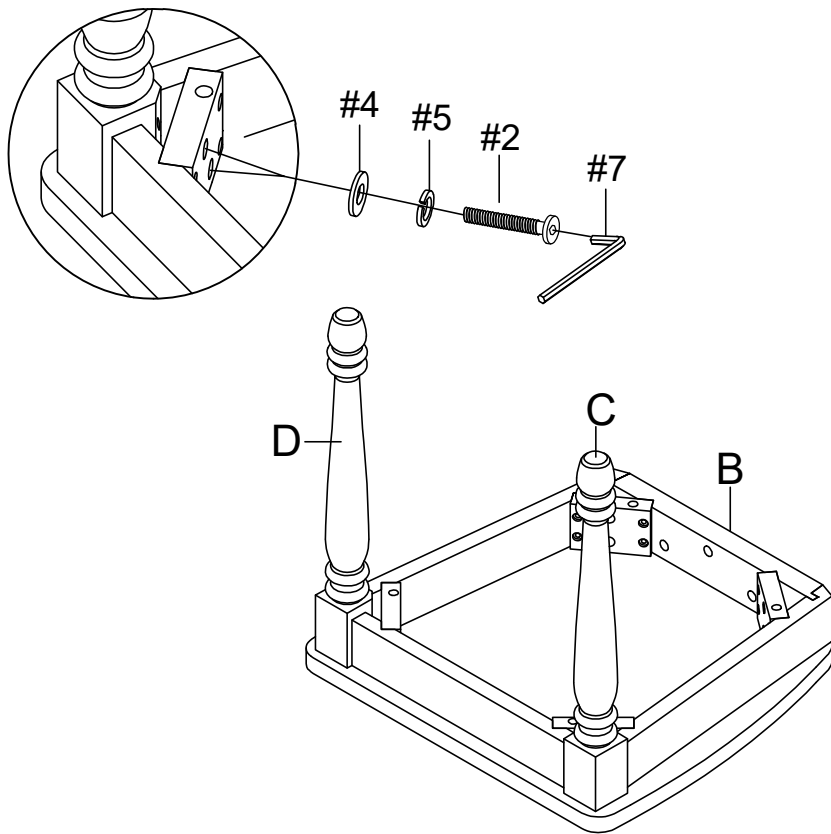

Phillips Head Screwdriver

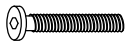



Step 1. Carefully turn seat frame (part B) upside down on a soft protective surface such as carpet. Attach left front leg (part C) and right front leg (part D) to seat frame (part B) using flat washers (part #4), spring washers (part #5), bolts (part #2) and allen wrench (part #7).
 Note: Please do not fully tighten bolts until unit is fully assembled.

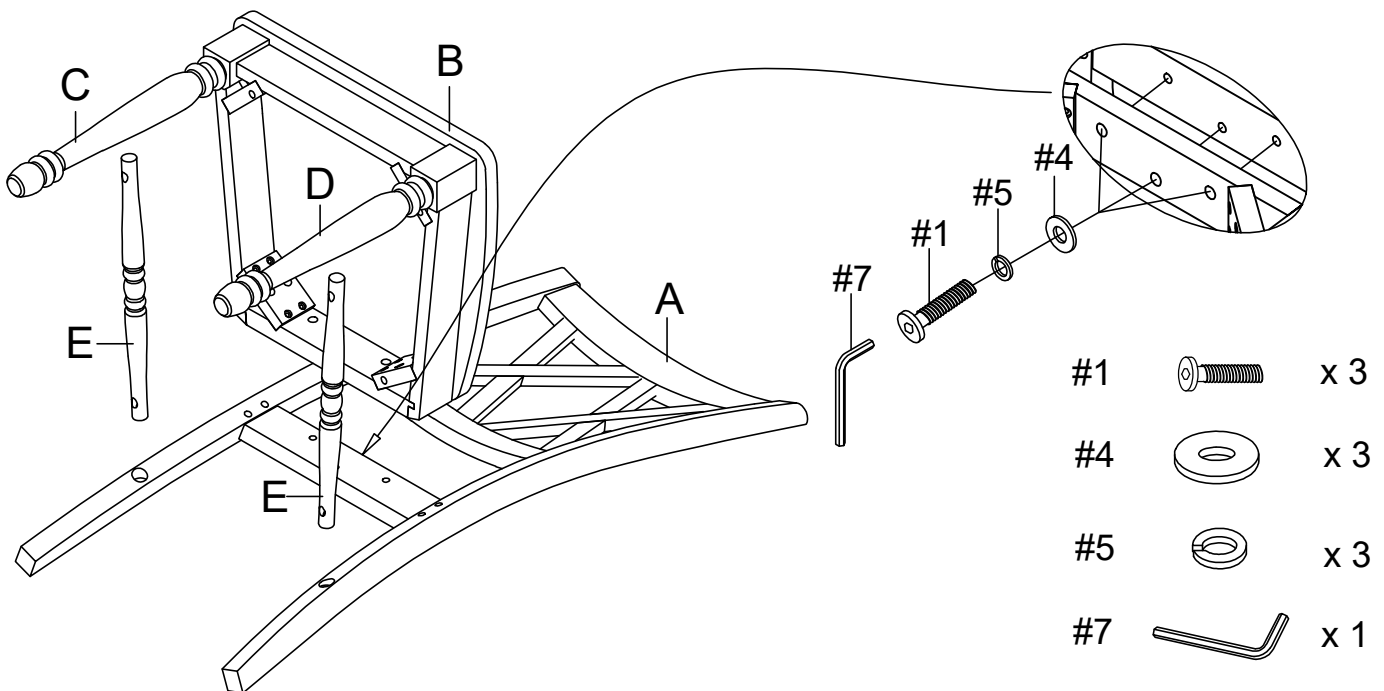

- #2  x 4
- #4  x 4
- #5  x 4
- #7  x 1

Step 2. Carefully place chair back (part A) down on a soft protective surface such as carpet. Attach assembled unit (parts B, C & D) to chair back (part A) using side stretchers (part E), flat washers (part #4), spring washers (part #5), short bolts (part #1) and allen wrench (part #7).



- #1  x 3
- #4  x 3
- #5  x 3
- #7  x 1

Step 3. Secure seat frame (part B) to chair back (part A) using flat washers (part #4), spring washers (part #5), long bolts (part #3) and allen wrench (part #7).

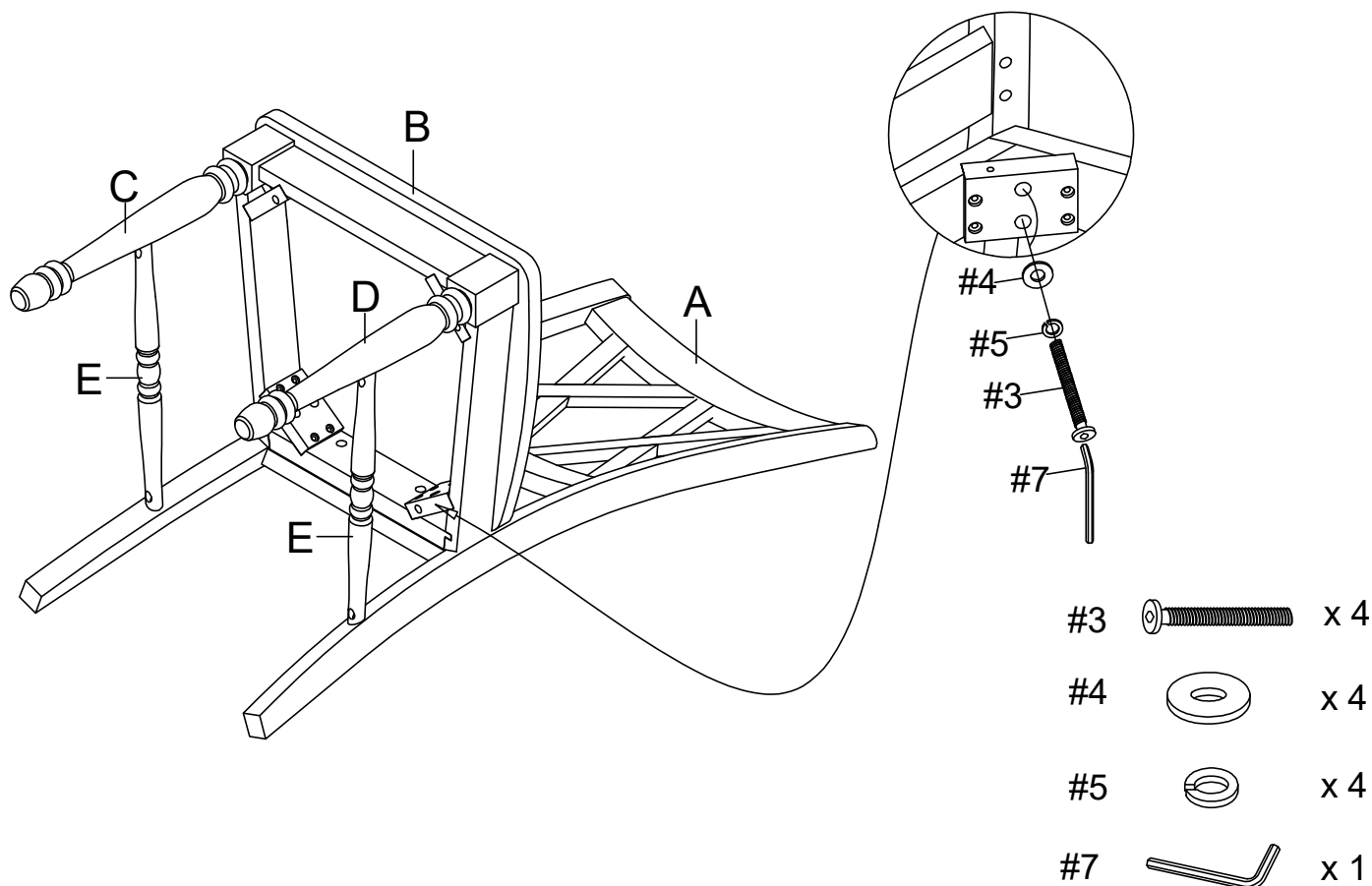

Step 4. Insert screws (part #6) into the holes of side stretchers (part E) and tighten using a phillips head screwdriver.

Note: Please fully tighten all bolts at this time.

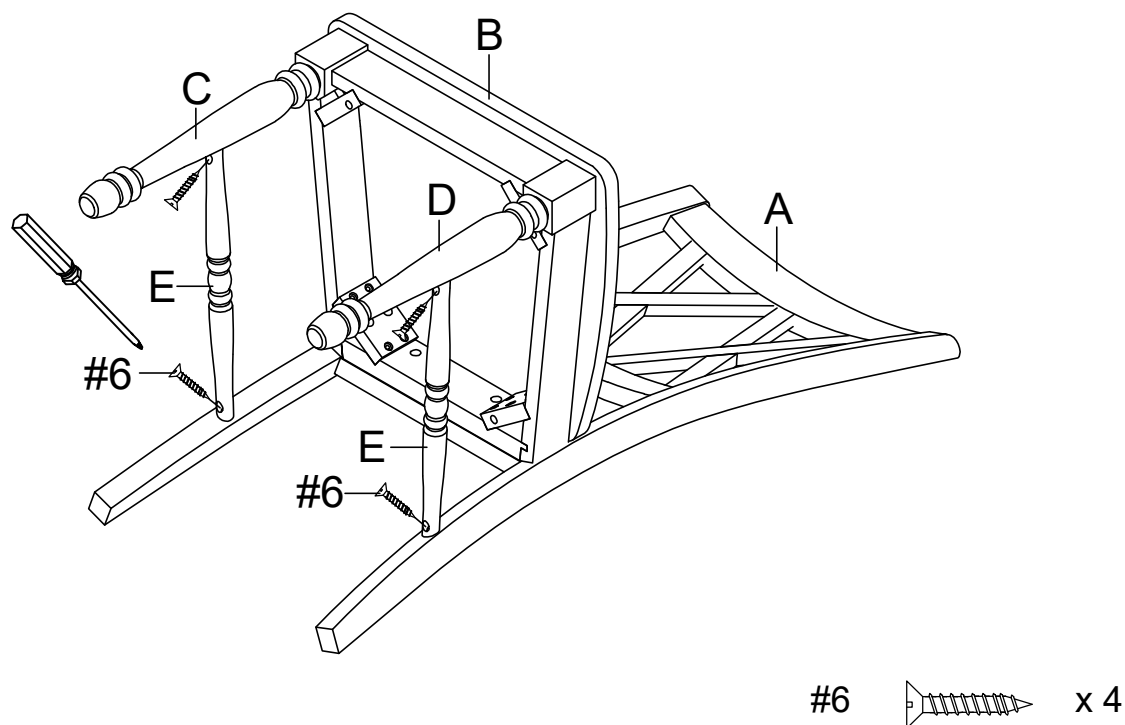

Step 5. Carefully turn unit upright. Repeat steps 1-4 to assemble remaining chair.

