

RVA1288BWC

Mixing Bowl Platform

RUVATI[®]
SPECIFICATION SHEET

Material: Food-safe Solid Composite

Composite Platform Dimensions:

17-1/4" (length) x 15-3/4" (width) x 1" (thick)

Items Included:

Solid Composite platform, 5 quart mixing bowl, perforated colander, black plastic lid, slicer attachment, and 2 different size grater attachments

Compatible with all LedgeFit Ruvati sinks



Care Instructions:

- Bowl, Colander and lid attachments are all dishwasher safe.
- Composite platform should only be hand-washed. Dry thoroughly after washing.

Purpose:

- **5 Quart Mixing Bowl:** Perfect for tossing salad, mixing batter or whipping cream.
- **Stainless Steel Colander:** Perforated colander is perfect for draining pasta or washing vegetables right on top of your sink.
- **Lid Included:** BPA-free plastic lid that fits tightly on both the mixing bowl or the colander allows you to easily store your leftover mix in the fridge.
- **Additional Attachments:** Perfect for slicing carrots or grating Parmesan onto tossed salads.

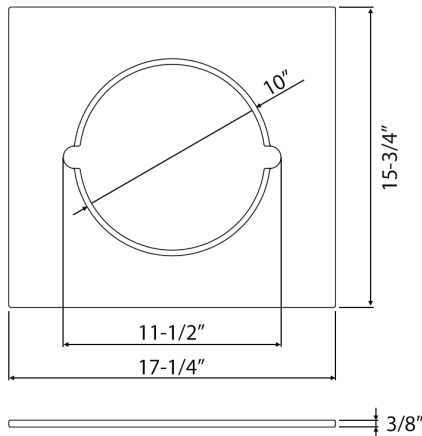

 California Prop 65 Warning:
Cancer and Reproductive Harm



X003UD919B

RUVATI USA

WWW.RUVATI.COM

PHONE: 1.855.478.8284
EMAIL: SUPPORT@RUVATI.COM

SCAN TO REGISTER
YOUR WARRANTY



www.ruvati.com/register