

Assembly Instructions

Caution : You must read this before you proceed.

CHAIR

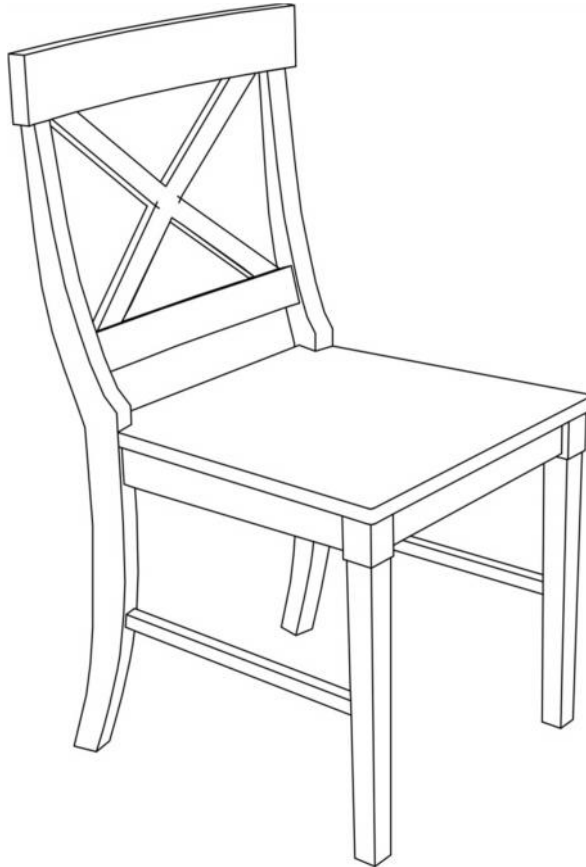





CAUTION : This Chair is NOT a TOY.
Keep your child / children at bay in the process of assembly.
For turning / flipping the Chair and to prevent damage to the Chair, 02 persons may be needed to execute this action.

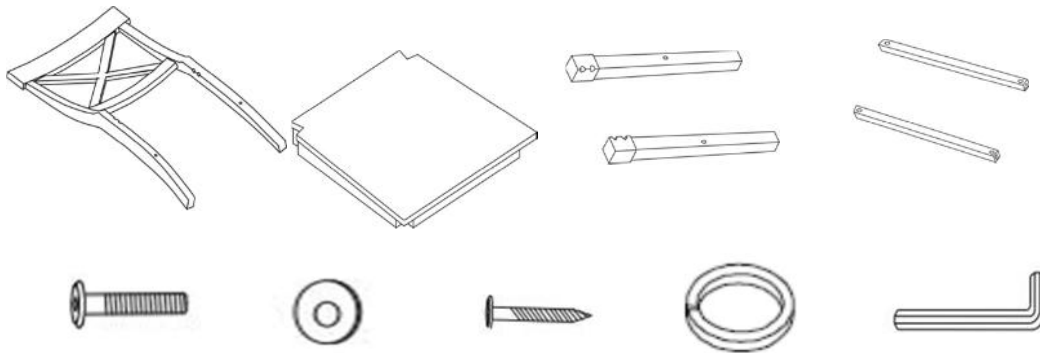



Assembly Preparation

Before Beginning Assembly:

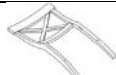

-  • Read instructions, cover to cover-
-  • Have 2 adults on hand for assembly-
-  • Do not assemble on flooring or carpet-
-  • Assemble on a clean non-marring surface (packing foam)-
-  • Save all packaging until finished-

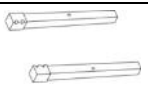
Parts List

NO.	Picture	Description	QTY
A		Chair Back /Hind Legs	1
B		Chair Seat	1
C		Front Legs	2
D		Side Rails (the side with holes as bottom side to face the floor after assembled)	2

Hardware

E		Bolts (M6x50mm)	9
F		Flat Washers	9
G		Screws (M4x30mm)	5
H		Spring Washers	9
I		Allen Key	1
K		Screwdriver	Not provided

Assembly Steps

Step 1

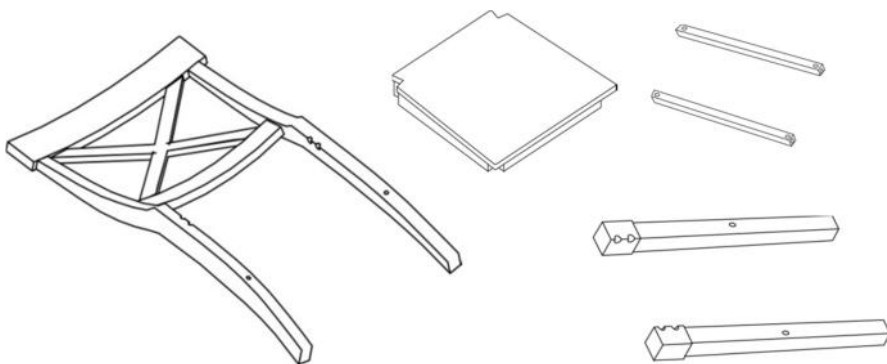

Unpack and place all parts on a clean soft surface.

Step 2

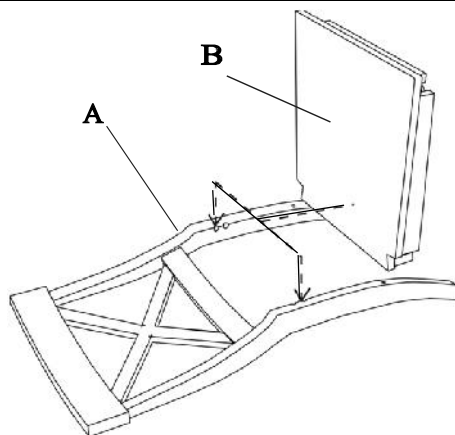

Place the Chair Back (A) onto a flat clean soft surface, as pictured above
Push the Chair Seat (B) in to the mounting position of the Chair Back (A) following the arrows shown in the picture.
Use your left hand to push the seat frame floorwards.
This action helps to ensure the Chair Seat (B) is pressed towards to the Chair Back (A) with no gap between these.

Step 3

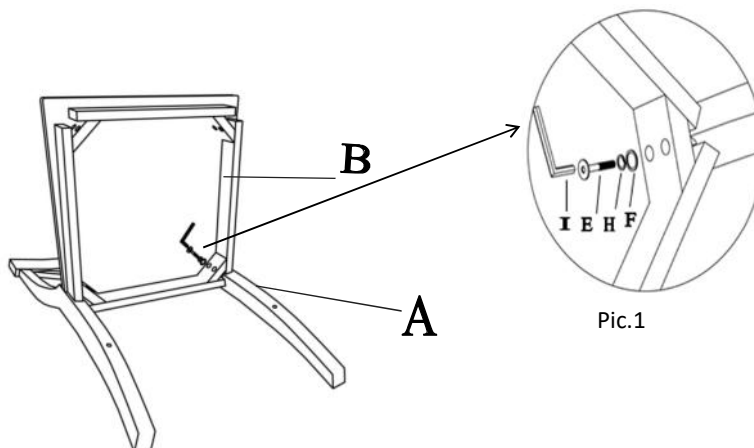

Secure the Chair Back (A) to the Chair Seat (B), using 2 Bolts (E) and Allen Key (I) in the sequence as shown in Pic. 1, above, using Flat Washer (F)- Spring Washer (H).

Then loosely tighten Bolt (E).

Repeat the same process for the other leg of Chair Back (A)
DO NOT OVERTIGHTEN THE BOLTS.

Step 4

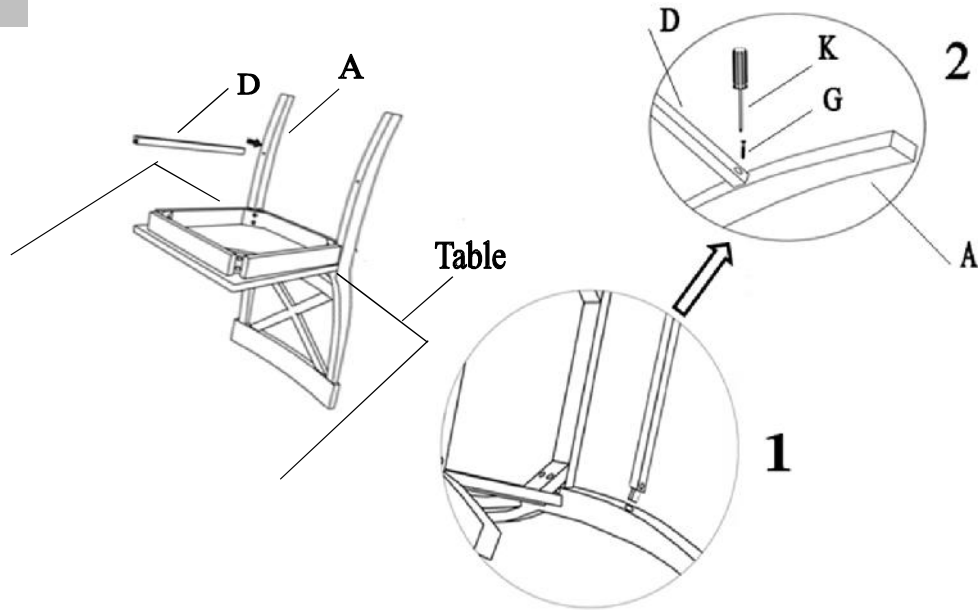

Next, place the chair onto the side of a table as seen in picture.
You will now have the chair bottom and legs facing skywards.

Place Side Rail (D) into the oval housing of Hind Leg of the Chair Back (A) following the arrow as shown in the picture

Then, using Screw (G) and Screwdriver (K) to attach the Side Rails (D) to the Chair Back (A) by using Screw (G) and Screwdriver (K) as shown in the round picture 1 and 2

Repeat the same process for the other Side Rail (D)

DO NOT OVERTIGHTEN THE SCREWS. OVER TIGHTENING COULD LEAD TO DAMAGE OF THE PRODUCT. TIGHTEN ONLY UNTIL SECURE.

Step 5

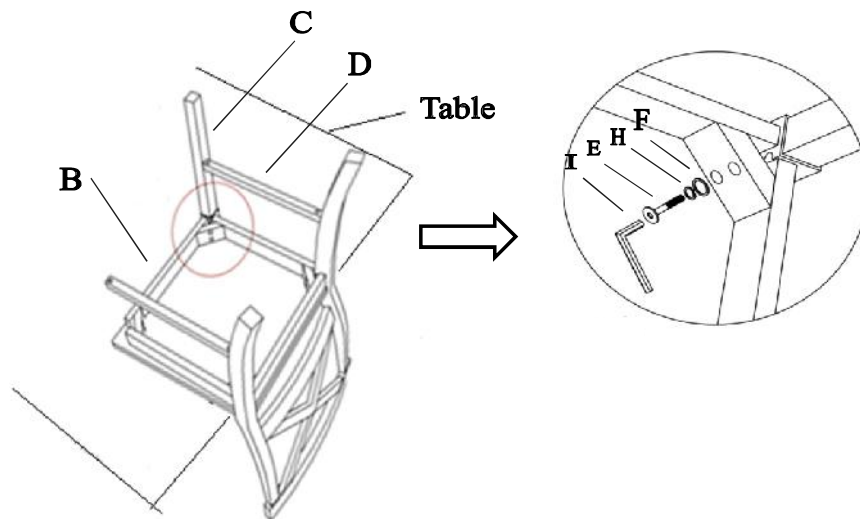

Place Front Leg (C) into the straight tenon of Side Rail (D) and the Chair Seat (B)

Secure Front Leg (C) to the Chair Seat (B) by using 2 Bolts (E) and Allen Key (I)

Order as shown in the round picture: Flat Washer (F)- Spring Washer (H), then tightening the Bolts (E).

DO NOT OVERTIGHTEN THE BOLTS. OVER TIGHTENING COULD LEAD TO DAMAGE OF THE PRODUCT.

TIGHTEN ONLY UNTIL SECURE AND STABLE

Step 6

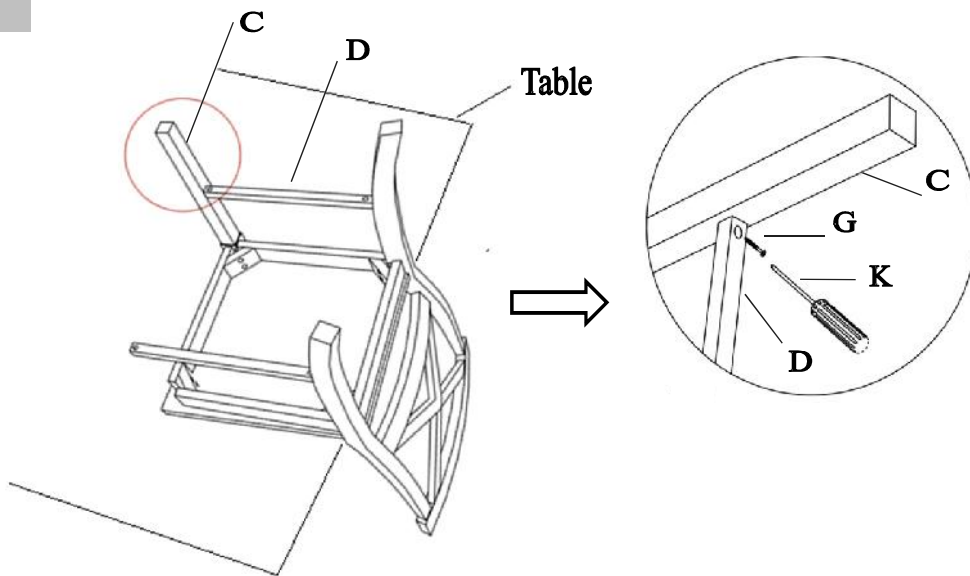

Secure the mortise of Front Leg (C) to the straight tenon of Side Rail (D) by using Screw (G) and Screwdriver (K) as shown in the round picture
Repeat the same process of step 4 and 5 to the other Front Leg (D)
DO NOT OVERTIGHTEN THE SCREWS

Step 7

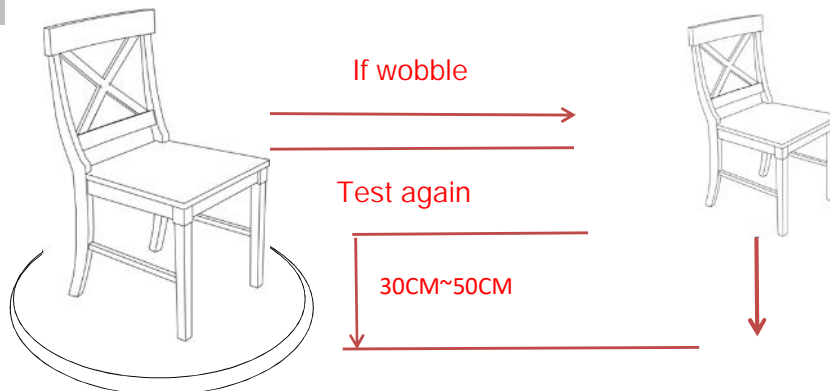

Place the Chair on a LEVEL SURFACE to see if it wobbles.
If it wobbles, lift the Chair to some 30cm to 50cm height from the ground.
Keep your feet and toes well away from the drop zone.
Drop the Chair freely and vertically with the four legs, hitting the ground, at the same time.
This Drop Test will help to ensure that all the screws and gaps to all reach full alignment status.
Test again for evenness on a LEVEL SURFACE.
If no wobbles found, proceed to tighten all the screws.
CAUTION: When tightening these screws, tighten sequentially.
DO NOT tighten any screw fully and then towards the next one.
This would cause the frame to warp.
If there is still wobbles, loosen the screws and execute this same drop tests.
WARNING!! IF CHAIR IS NOT STABLE , IT COULD LEAD TO DAMAGING THE PRODUCT.

Step 8



Turn the Chair upright carefully
Proceed to fully tighten all Bolts (E) and Screws (G), in a sequential manner.
The Chair is ready to use now.

Care & Maintenance



• Do not put hot items directly on furniture surface.



• Do not clean furniture with harsh cleansers or polish.



• Do not place furniture under direct sunlight.



• Do not place furniture near heating or cooling vents.



• Do not write on furniture without a padded barrier to protect the surface.



• Do not place furniture outside. For indoor use only.



• Not for commercial use. For residential use only.



• Stains may be removed with mild soap solution and damp cloth.



• Dust and pick-up spills using a clean, non-colored, lint-free cloth.