

# FIRAVOE<sup>®</sup>



SWIVEL & ADJUSTABLE BARSTOOL

Assembly Manual Bar Chair

## Guide of Manual

- Instruction should be read carefully. It is very important to ensure each step followed in correct order and avoid any unnecessary troubles.
- Please check to make sure all parts are included as stated in the user manual when you unpack the product.
- The manual may not cover every detail of all possible situations and assembly steps. Please contact us if further information and help are needed.

## WARNING

- It's unnecessary to use any electric drill. Please use it in low gear If you need.
- Its kindly advised to assemble this product on a carpeted floor to protect it from being scratched.
- Please pay attention to the sharp corners during assembly. We recommend the use of gloves to prevent the undesired injury.
- Prior to use, please check to see if there's any loosening screw or part. Make sure that each screw and part is correctly installed and securely fastened.
- Small parts are included. Please keep the product away from children while assembling. Do not let children play or jump on the product. Do not stand on the item or use as a step.
- The product can expose you to chemicals including wood dust, which is known to the state of California to cause cancer. For more informa-

## Disposal



Dispose of the product according to local regulations. if in doubt, consult your local authorities.

## Care and Maintenance

- Using solvents of any kind on your furniture may damage the finish.
- Use a soft, clean cloth that will not scratch the surface when dusting.
- Never use water to clean your furniture as it may cause damage to the finish.
- There's no need to use furniture polish. If you need, test it first in an inconspicuous area.
- Liquid spills should be removed immediately. Gently blot the spill with a soft clean cloth to avoid rubbing.

## Feedback and help

We would love to hear your feedback. To ensure we are providing the best customer experience possible please consider writing a customer review.

Scan QR Code below with your phone camera or QR reader:

US:

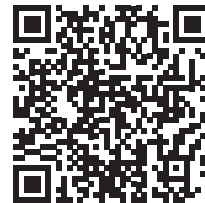

If you need help with your product, please dont be hesitate to use the website or number below:



US: [amazon.com/gp/help/customer/contact-us](https://amazon.com/gp/help/customer/contact-us)

Email: [heugah@ivychairs.com](mailto:heugah@ivychairs.com)



+1 434-274-1006 (US Phone Number)  
Monday-Friday GMT-7 6: 00 p.m.-12:00 a.m.

# Components and Tools



A (x1)

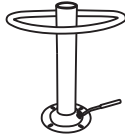

B (x1)



C (x1)



D (x1)

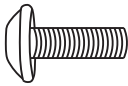

M6x25mm

E (x2)



M6x16mm

F (x2)



M6

G(x1)

## Particular attention

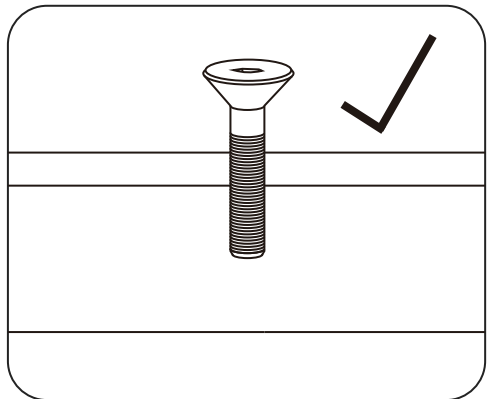
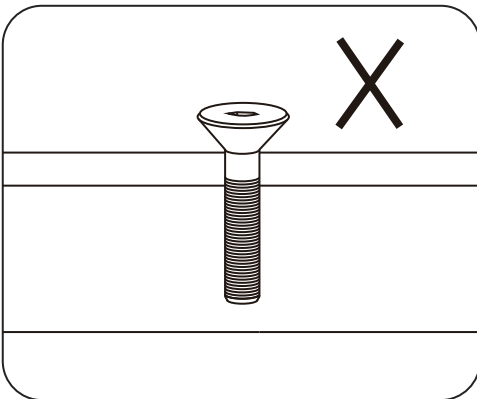

**Do not tighten the screws until all the screws have been installed in their corresponding locations**

## STEP ONE



A (x1)



B (x1)



C (x1)



D (x1)

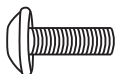

M6x25mm

E (x2)



M6x16mm

F (x2)



M6

G(x1)

**Please check and ensure all accessories are in the package. If any accessories are missing, please contact us for assistance.**

✉ Email: [heugah@ivychairs.com](mailto:heugah@ivychairs.com) 📞 +1 434-274-1006 (US Phone Number)

## STEP TWO

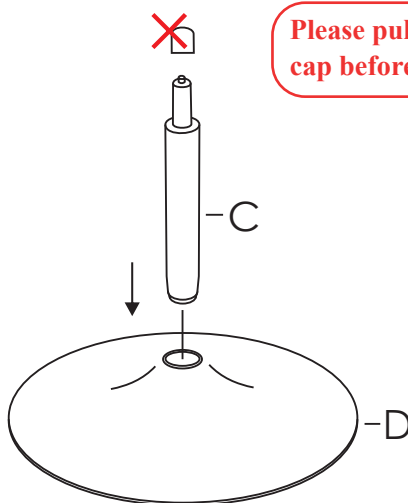

**Please pull off the black cap before using.**

**Insert part C into part D.**

## STEP THREE

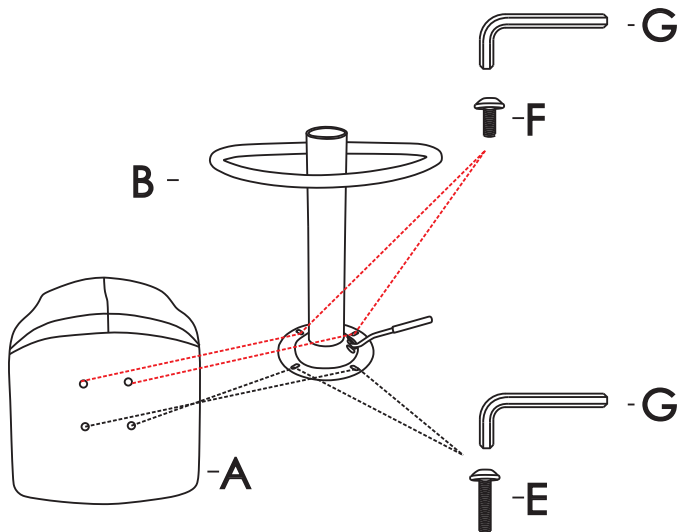

Align the four screw holes of A and B and tighten the screws with the provided wrench.

## STEP FOUR

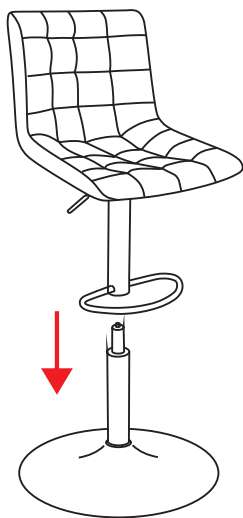

Assemble the upper and lower parts together.

## STEP FIVE



The raising of the chair can not be done by sitting on the chair, but by standing next to it and triggering the gas lever. The lowering of the height of the chair requires sitting on the chair and triggering the gas lever and weighing more than 100 pounds.

**Assembly completed.**

## FREQUENTLY ASKED QUESTIONS:

**Q: What should I do if I encounter missing accessories and find that the product has defects?**

A: Please contact us via the after-sales email and phone number provided in the manual. We will help you solve the problem.

**Q: I have applied for a return but did not receive a free return shipping label. What should I do?**

A: Please contact us via the after-sales email and phone number provided in the manual. Provide your Amazon order number, and we will provide you with a free return label if it meets Amazon's return policy.

**Q: What should I pay attention to when sending back the returned goods?**

A: Before returning the goods, please restore the original packaging of the product to ensure it matches the condition before unpacking. Then contact us via the after-sales email and phone number provided in the manual. Take photos to confirm the packaging condition with us before returning.

**Q: I really like your products and service and want to share my shopping experience with more people. What should I do?**

A: You can write down your shopping experience and product usage experience so that more people can see your comments and help them make purchasing decisions.