











Assembly Instructions

Caution : You must read this before you proceed

Care & Maintenance

- ⊘  ● Not for commercial use. For residential use only.
- ⊘  ● Prolonged exposure to rain may cause rusting which can stain floors.
- ⊘  ● Do not put hot items directly on furniture surface.
- ⊘  ● Do not clean furniture with harsh cleansers or polish.
- ✓  ● To obtain the longest lifespan of your outdoor products, minimizing exposure to direct sunlight is recommended.
- ⊘  ● Children should not climb or jump on the furniture.
- ⊘  ● Do not write on furniture without a padded barrier to protect the surface.
- ✓  ● To obtain the longest lifespan of your outdoor products, avoid extended and lengthy exposure to rain, snow, and direct sunshine. Whenever possible cover the product and /or place under patio or awnings.
- ⊘  ● Stains may be removed with mild soap solution and damp cloth.
- ✓  ● Keep away from sources of ignition.
- ✓  ● Dust and pick-up spills using a clean, non-colored, lint-free cloth.

Please look in Back Cushion for hardware packs

CHAIR

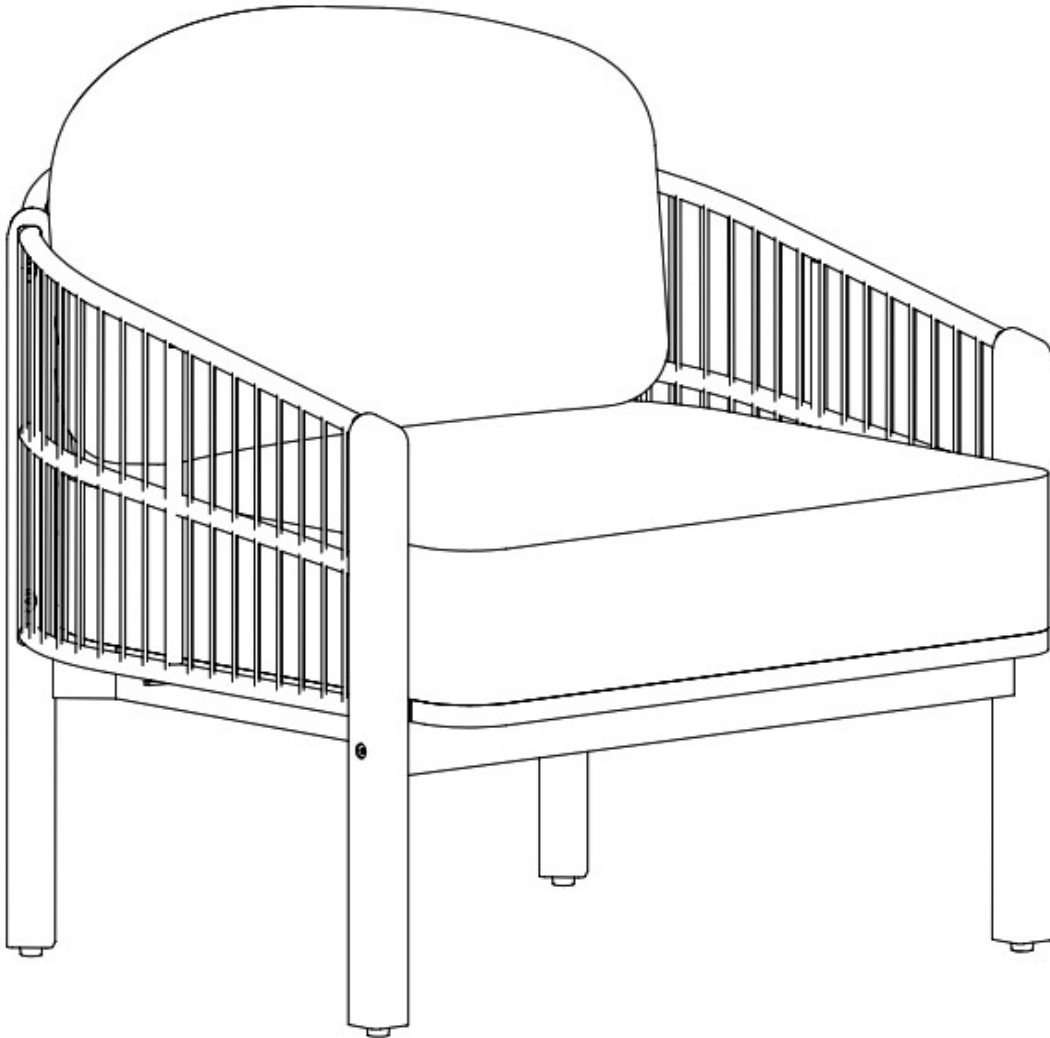





Caution: This Chair is NOT a TOY.

Keep your child / children at bay in the process of assembly.

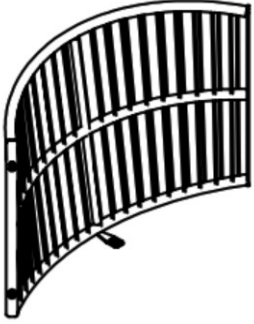

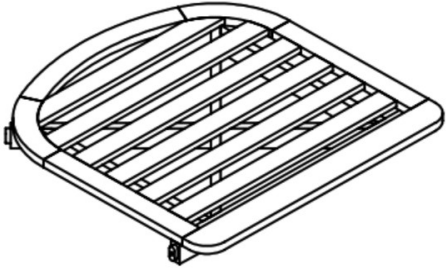
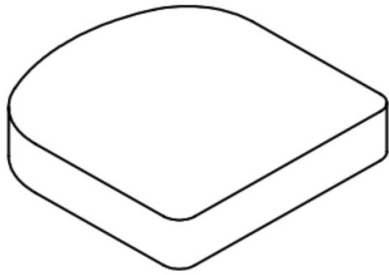

For turning the Chair and to prevent damage to the Chair, 02 persons may be needed to execute this action.

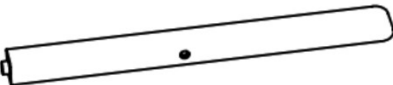
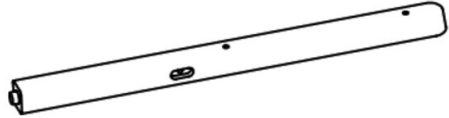
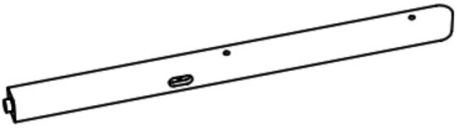
Parts List

Label	Picture	Description	QTY
A		Right Rope Frame	1
B		Middle Rope Frame	1
C		Left Rope Frame	1
D		Seat Frame	1
E		Cushion	1

F		Back Cushion	1
G		Left Front Leg	1
H		Right Front Leg	1
I		Left Back Leg	1
J		Right Back Leg	1

Hardware

Label	Picture	Description	QTY
①		Bolt (M6*50mm)	5
②		Bolt (M6*20mm)	4
③		Bolt (M6*15mm)	13
④		Flat Washer Rings	4
⑤		Allen Wrench	2

Assembly Preparation

Before Beginning Assembly

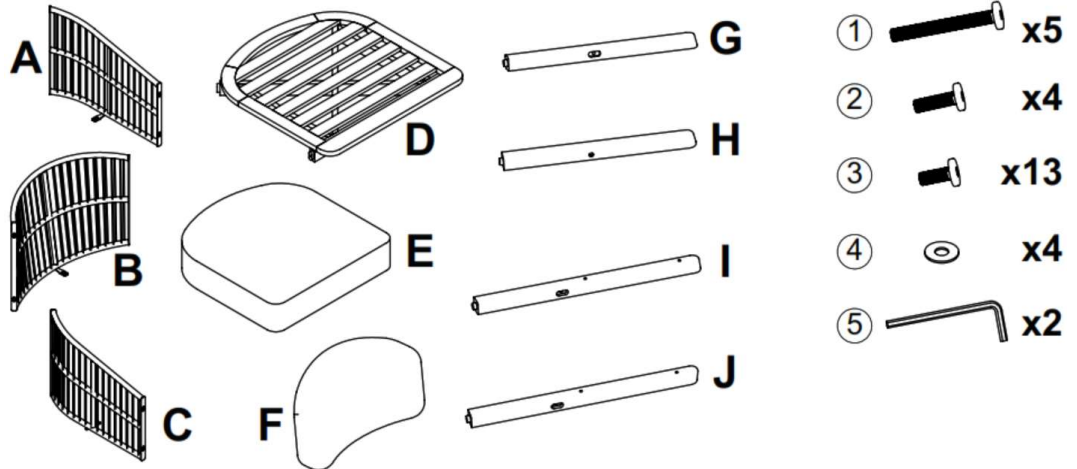

- Read instructions, cover to cover-



- Have 2 adults on hand for assembly-



- Do not assemble on flooring or carpet-



- Assemble on a clean non-marring surface (packing foam)-



- Save all packaging until finished-

Assembly Steps

Overview

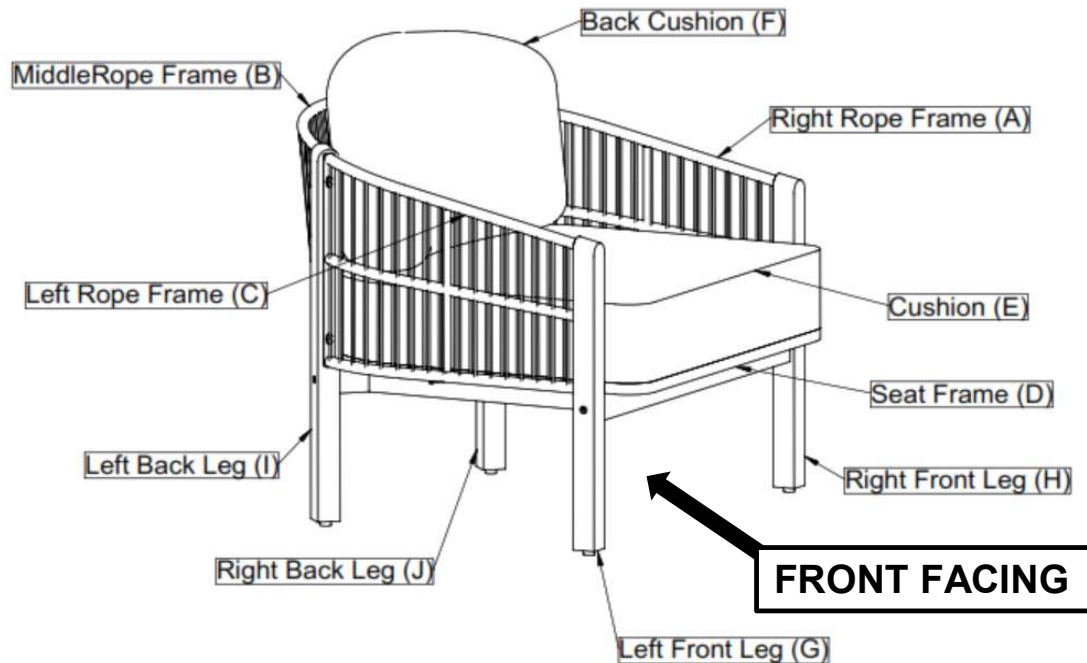

This Chair has multiple parts and may require up to 45 minutes to assemble. To give you an overview of the Chair parts, the above picture is to help you put the various parts into perspective. Please read through the instructions below to familiarise yourself with the parts and steps before assembly.

Step 1

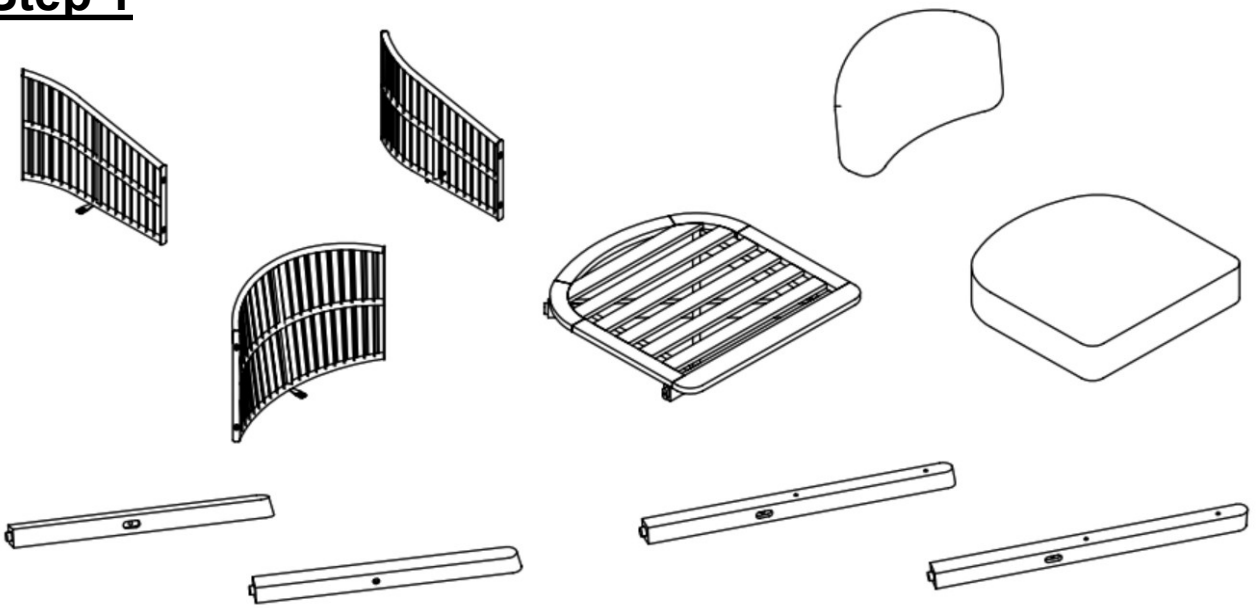

Unpack and place all parts on a clean, non-marring surface.

Step 2

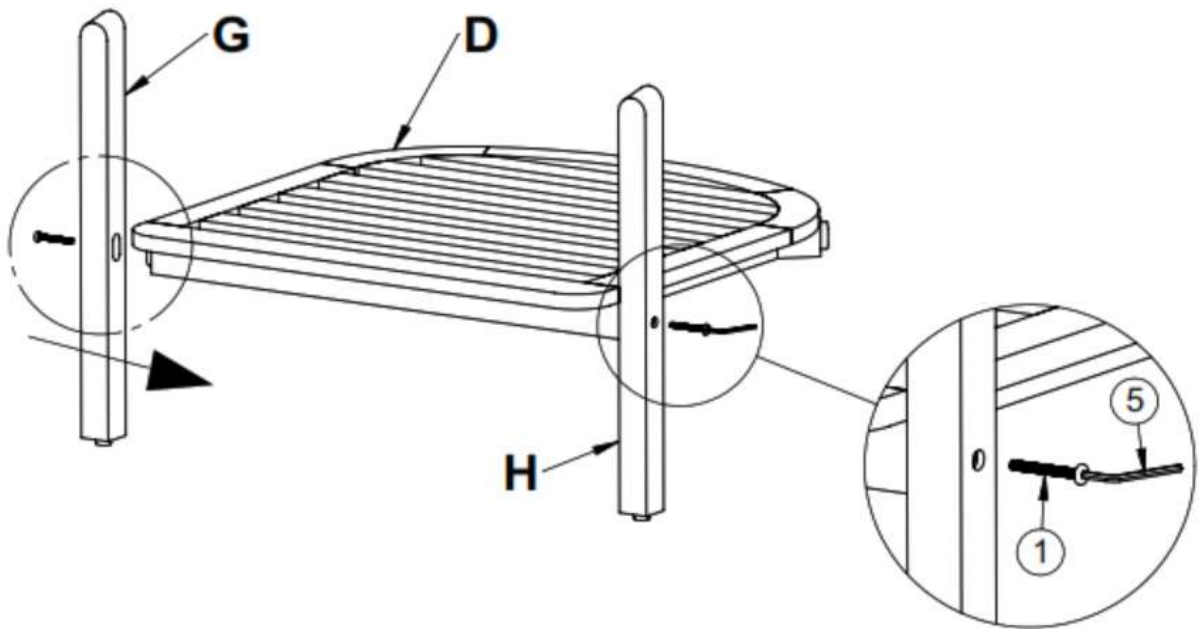

Place the 2 Front Legs into the Seat Frame (D), making sure to place the Left Front Leg (G) and Right Front Leg (H) correctly, as shown above. Install the 2 Bolts (①) through the mounting positions using Allen Wrench (⑤), as shown above picture.

Do not fully tighten the Bolts.

Step 3

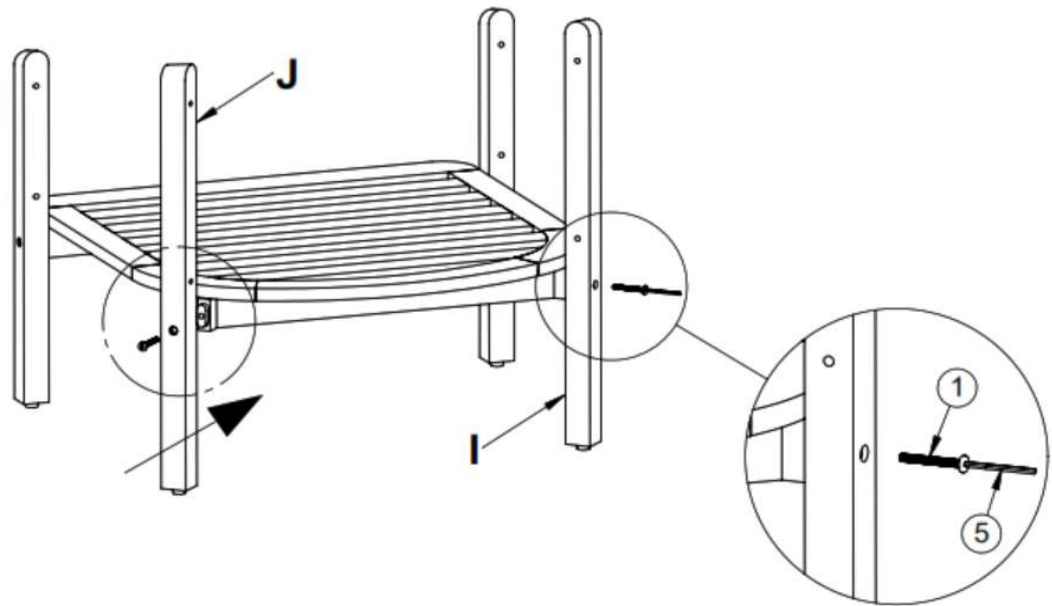

Repeat the same process as Step 2 to affix 2 Back Legs into the Seat Frame (D), making sure to place the Left Back Leg (I) and Right Back Leg (J) correctly, as shown above. Install the 2 Bolts (①) through the mounting positions using Allen Wrench (⑤), as shown above picture.

Do not fully tighten the Bolts.

Step 4

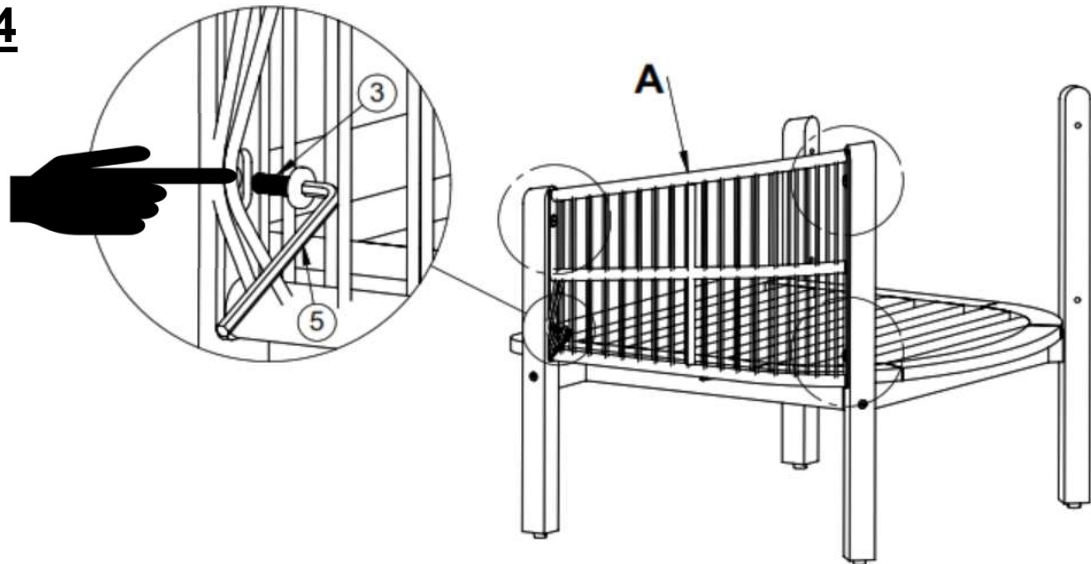

Place the Right Rope Frame (A) into the Seat Frame (D) with 2 front and back right legs (H)-(J), align the bolt holes. Use your hands to pull the 2 strings at the bolt holes as shown above, creating space for easy assembly. Install the 4 Bolts (③) through the mounting positions using Allen Wrench (⑤), as shown above picture.

Do not fully tighten the Bolts.

Step 5

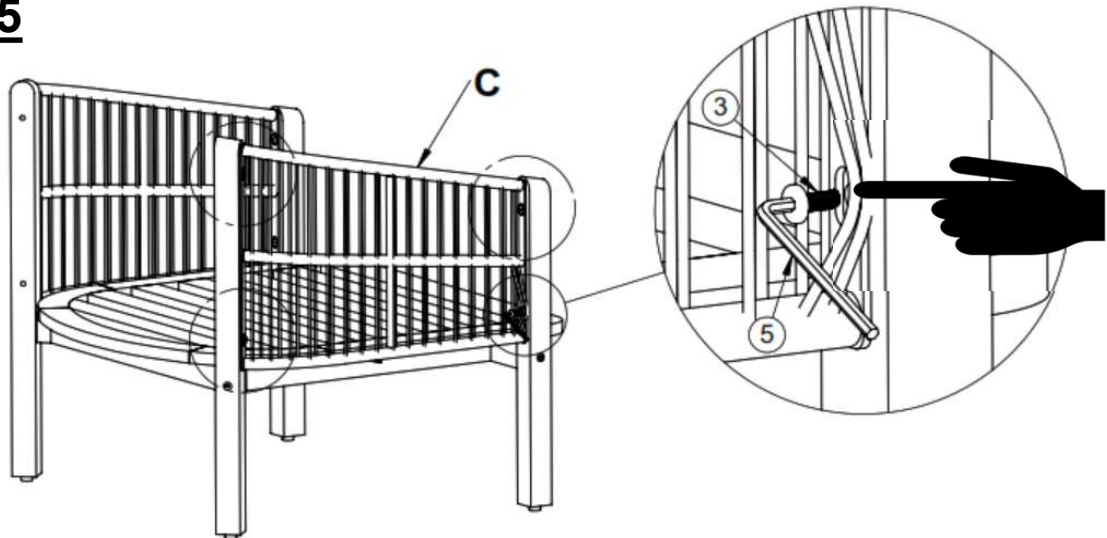

Repeat the same process as Step 4.

Place the Left Rope Frame (C) into the Seat Frame (D) with 2 front and back left legs (G)-(I), align the bolt holes. Use your hands to pull the 2 strings at the bolt holes as shown above, creating space for easy assembly. Install the 4 Bolts (③) through the mounting positions using Allen Wrench (⑤), as shown above picture.

Do not fully tighten the Bolts.

Step 6

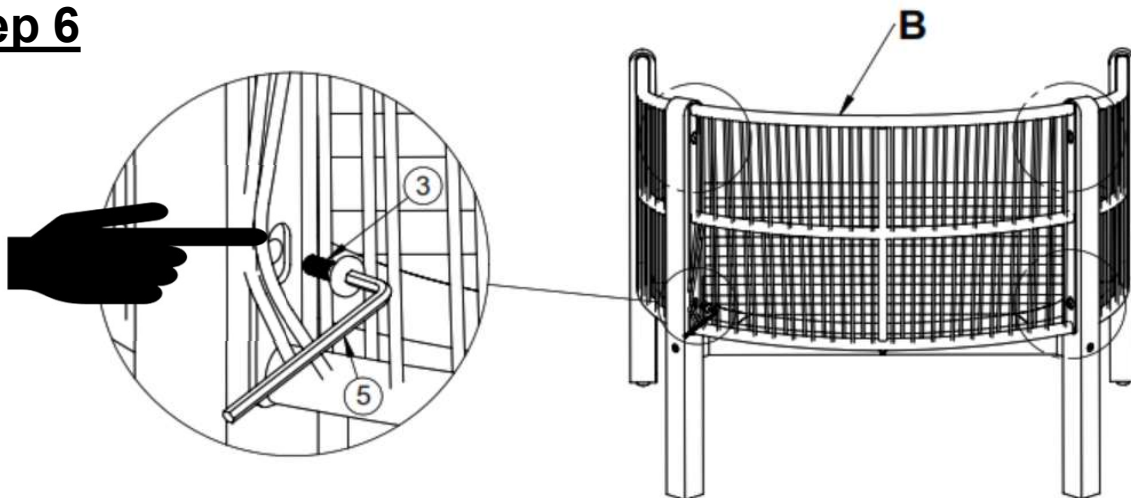

Repeat the same process as Step 4 and Step 5.

Place the Middle Rope Frame (B) into the Seat Frame (D) with 2 back legs (I)-(J), align the bolt holes. Use your hands to pull the 2 strings at the bolt holes as shown above, creating space for easy assembly. Install the 4 Bolts (③) through the mounting positions using Allen Wrench (⑤), as shown above picture.

Do not fully tighten the Bolts.

Step 7

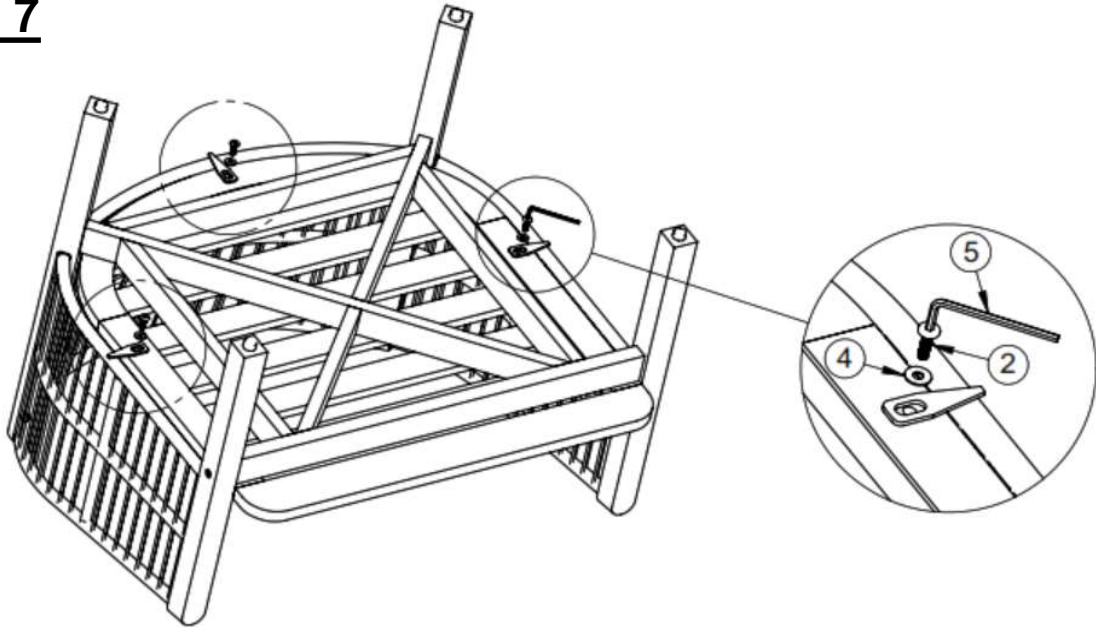

Turn the Chair upside down on a safe, scratch-free surface. Align the bolt holes of Rope Frame (A)-(B)-(C) with Seat Frame (D). Install the 3 Bolts (②) with 3 Washers (④) through the mounting positions using Allen Wrench (⑤), as shown above picture.

Fully tighten the Bolts, both step 2, 3, 4, 5 and 6.

Step 8

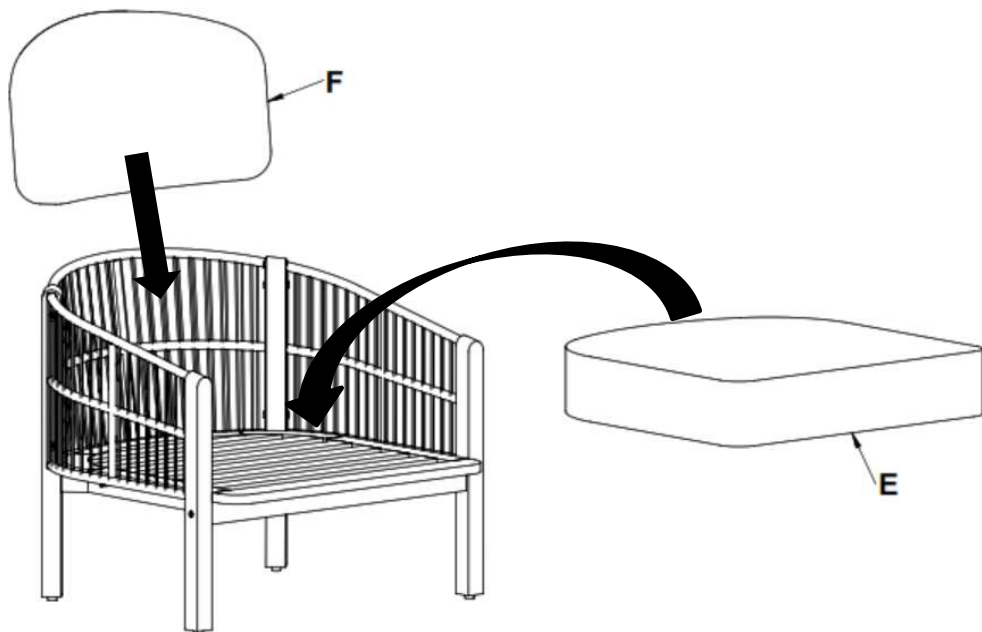

Stand the Chair up, Use both hands to press the seat down into the floor. This will help the parts achieve full alignment.

Check for vibration and tighten the bolts one more time.

Place the Cushion (E) and Back Cushion (F) into the seat.

Step 9

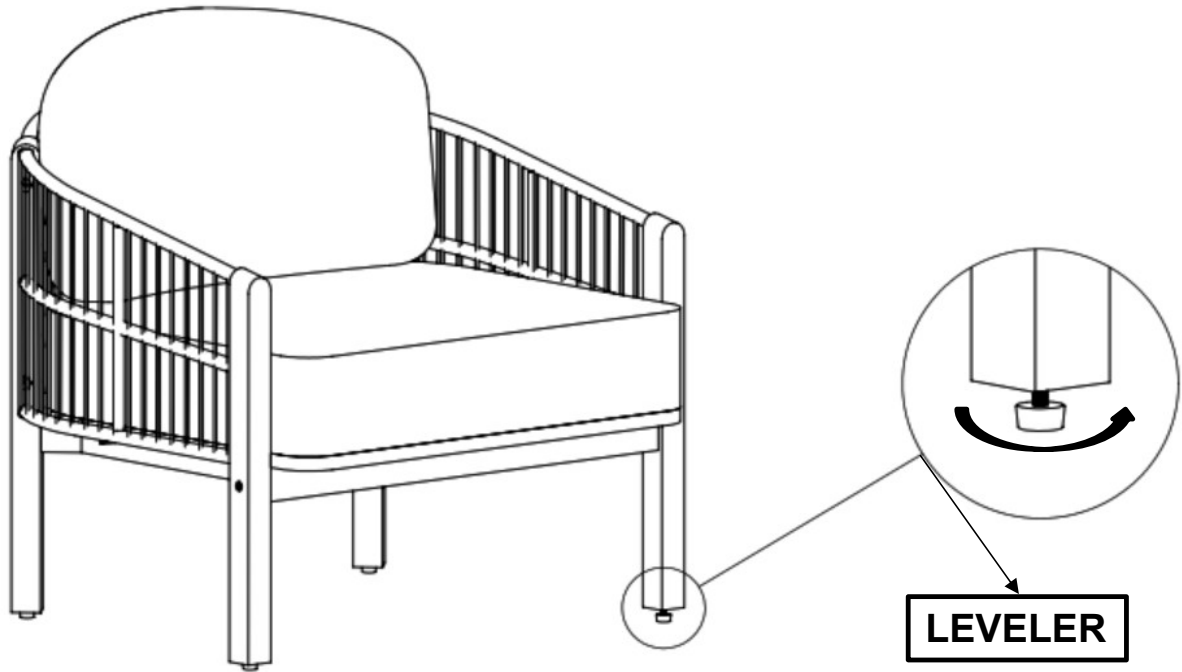

Your Chair is ready for use. This Chair can only be used on the flat, level surface.

On uneven surfaces, adjust the bases of the four legs.