

Installation & Assembly

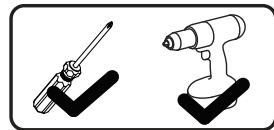

EN_IMPORTANT, RETAIN FOR FUTURE REFERENCE: READ CAREFULLY.
FR_IMPORTANT: A LIRE ATTENTIVEMENT ET À CONSERVER POUR CONSULTATION
ULTÉRIEURE.
ES_IMPORTANTE, LEA Y GUARDE PARA FUTURAS REFERENCIAS.
DE_„WICHTIG! SORGFÄLTIG LESEN UND FÜR SPÄTER NACHSCHLAGEN AUFBEWAHREN.“
IT_IMPORTANTE! CONSERVARE IL PRESENTE MANUALE PER FUTURO RIFERIMENTO E
LEggerlo ATTENTAMENTE.

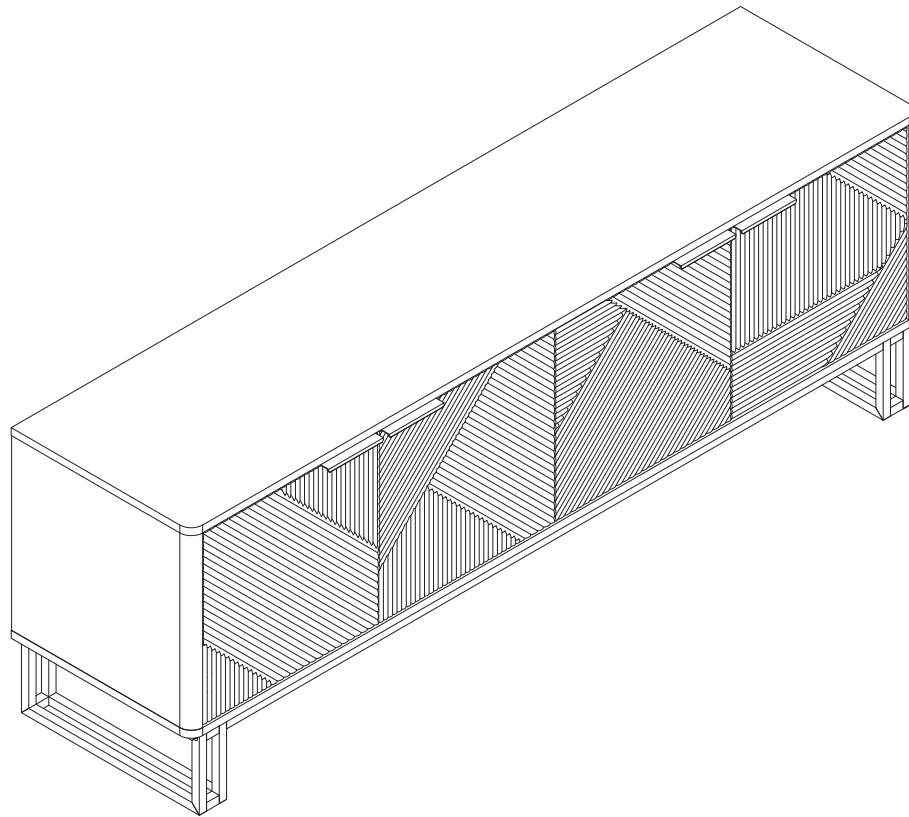

DE

Warnung: Die maximale Belastbarkeit dieses Möbels beträgt: 50 kg, bitte nicht überlasten!

EN

Warning: The maximum load-bearing capacity of this furniture is: 50kg, please do not overload!

FR

Avertissement : La capacité de charge maximale de ce meuble est de : 50 kg, merci de ne pas surcharger !

IT

Attenzione: la capacità di carico massima di questo mobile è: 50 kg, non sovraccaricare!

ES

Advertencia: La capacidad máxima de carga de este mueble es:50 kg, ¡no lo sobrecargue!

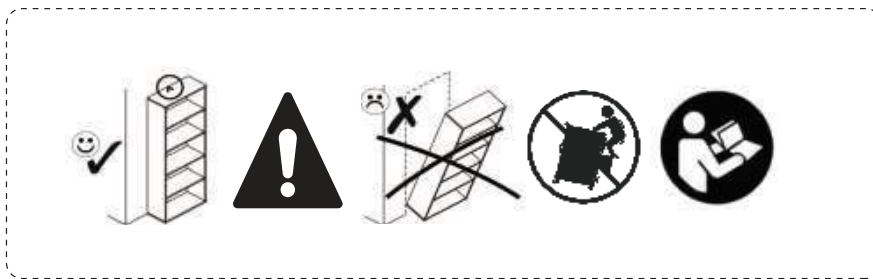

GB-Anchor unit to stud or wall.

DO NOT allow children to climb on unit.

Always use on a level, even surface.

Always lift the item with two people to reposition.

DO NOT place the item next to a radiator or direct sunlight.

DO NOT place hot or cold items directly onto the surface.

DO NOT put the product in a humid environment.

FR-Fixer l'appareil à un montant ou à un mur.

NE PAS laisser les enfants grimper sur l'appareil.

Toujours utiliser l'appareil sur une surface plane et régulière.

Toujours soulever l'article à deux pour le repositionner.

NE PAS placer l'article à côté d'un radiateur ou de la lumière directe du soleil.

NE PAS placer d'objets chauds ou froids directement sur la surface.

NE PAS placer le produit dans un environnement humide.

DE-Verankern Sie das Gerät an einem Ständer oder einer Wand.

Erlauben Sie Kindern NICHT, auf das Gerät zu klettern.

Benutzen Sie das Gerät immer auf einer ebenen, glatten Fläche.

Heben Sie das Gerät immer mit zwei Personen an, um es neu zu positionieren.

Stellen Sie das Gerät NICHT in der Nähe eines Heizkörpers oder in direktem Sonnenlicht auf.

Stellen Sie KEINE heißen oder kalten Gegenstände direkt auf die Oberfläche.

Stellen Sie das Produkt NICHT in einer feuchten Umgebung auf.

IT-Ancorare l'unità a un pilastro o a una parete.

NON permettere ai bambini di arrampicarsi sull'unità.

Utilizzare sempre su una superficie piana e uniforme.

Sollevarlo sempre l'articolo con due persone per riposizionarlo.

NON posizionare l'articolo vicino a un radiatore o alla luce diretta del sole.

NON collocare oggetti caldi o freddi direttamente sulla superficie.

NON collocare il prodotto in un ambiente umido.

ES-Anclar la unidad a un montante o pared.

NO permita que los niños se suban a la unidad.

Utilícelo siempre sobre una superficie plana y nivelada.

Levante siempre el artículo con dos personas para recolocararlo.

NO coloque el artículo cerca de un radiador o de la luz solar directa.

NO coloque objetos calientes o fríos directamente sobre la superficie.

NO coloque el producto en un ambiente húmedo.

NON collocare il prodotto in un ambiente umido.

EN

Dear customer,

Thank you for purchasing this product. So that your appliance serves you well, please read all the instructions in this user's manual. If you have any questions, please contact our customer care center.

FR

Cher client,

Nous vous remercions d'avoir acheté ce produit. Afin que vous puissiez profiter pleinement de votre appareil, veuillez lire toutes les instructions de ce manuel d'utilisation. Si vous avez la moindre question, veuillez contacter notre centre d'assistance à la clientèle.

DE

Sehr geehrter Kunde,

Vielen Dank, dass Sie dieses Produkt erworben haben. Damit Ihr Gerät Ihnen gute Dienste leistet, lesen Sie bitte alle Hinweise in diesem Benutzerhandbuch. Wenn Sie Fragen haben, wenden Sie sich bitte an unser Kundendienstzentrum.

ES

Queridos clientes,

Gracias por comprar este producto. Para que su electrodoméstico le sirva mejor, lea todas las instrucciones de este manual del usuario. Si tiene alguna pregunta, comuníquese con nuestro Centro de Atención al Cliente.

IT

Caro Cliente,

Grazie per aver acquistato questo prodotto. Per servirti meglio con questo apparecchio ti prego di leggere tutte le istruzioni in presente manuale utente. In caso di dubbio, si prega di contattare il nostro centro assistenza clienti.

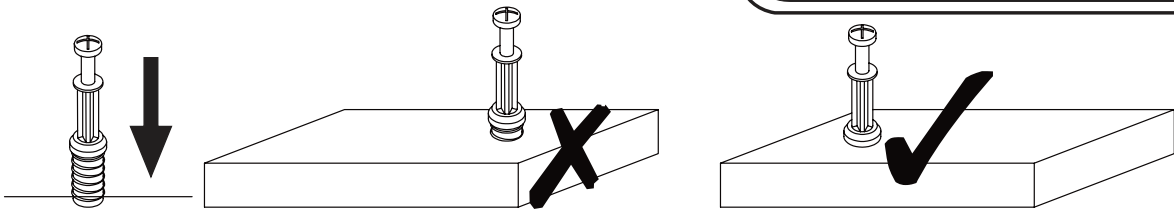

EN_QUICKFIT: Tighten quickfit until shoulder is flush with panel. Do not overtighten or undertighten.

FR_RACCORD RAPIDE: Faites serrer le raccord rapide jusqu'à ce que l'épaule soit parfaitement encastré dans le panneau. Il ne faut ni trop serrer ni insuffisamment serrer.

ES_QUICKFIT: Apriete quickfit hasta que el hombro se descargue con el panel. NO lo sobreapriete ni lo apriete poco.

DE_QUICKFIT: Ziehen Sie den Quickfit fest, bis die Schulter mit der Platte bündig ist. Bitte nicht zu fest oder zu schwach anziehen.

IT_MONTAGGIO RAPIDO: Stringere il montaggio rapido fino a quando la spalla è a filo con il pannello, non stringere troppo o troppo poco.

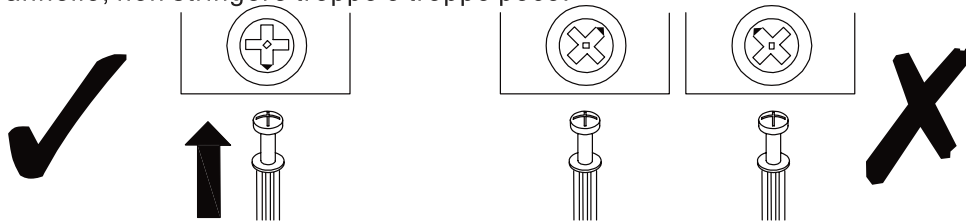

EN_CAM LOCK: When fitting cam lock, ensure starting position is correct before you insert connecting quickfit.

FR_SERRURE BATTEUSE: Avant d'insérer la serrure batteuse, veillez à la bonne orientation avant d'insérer le raccord rapide.

ES_CIERRE DE LA CÁMARA: Cuando instale el cierre de la cámara, asegúrese de que la posición de inicio es correcta antes de que inserte el quickfit conector.

DE_CAM-LOCK: Achten Sie bei der Montage des Cam-Locks auf die richtige Ausgangsposition, bevor Sie den Quickfit einsetzen.

IT_BLOCCAGGIO A CAMMA: Quando si monta il bloccaggio a camma, assicurarsi che la posizione iniziale sia corretta prima di inserire il montaggio rapido di collegamento.

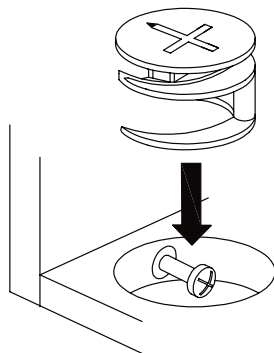

EN_Quickfit head should be in the centre of the cam lock when the two panels are joined.

Cam lock should be inserted before quickfit.

FR_Lorsque les deux panneaux sont assemblés, la tête du raccord rapide doit reposer au centre de la serrure batteuse. Il faut insérer la serrure batteuse avant le raccord rapide.

ES_El cabezal del quickfit debe estar en el centro del cierre de la cámara cuando se unan los dos paneles.

Se debe insertar el cierre de la cámara antes que el quickfit.

DE_Der Quickfit-Kopf sollte sich in der Mitte des Cam-Locks befinden, wenn die beiden Platten zusammengefügt sind.

Der Cam-Lock sollte vor dem Quickfit eingesetzt werden.

IT_La testa del montaggio rapido deve trovarsi al centro del bloccaggio a camma quando i due pannelli sono uniti.

Il Bloccaggio a Camma deve essere inserito prima del montaggio rapido.

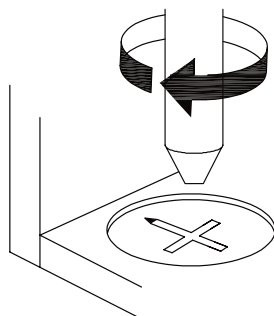

EN_Turn cam lock clockwise to tighten.

FR_Faites tourner la serrure batteuse dans le sens des aiguilles d'une montre pour la resserrer.

ES_Gire el cierre de la cámara en sentido horario para apretarlo.

DE_Drehen Sie den Cam-Lock im Uhrzeigersinn, um ihn festzuziehen.

IT_Ruotare il bloccaggio a camma in senso orario per stringere.

EN It may be necessary to adjust the hinges so that the doors align. Use the instructions below as a guide.

FR Il est parfois nécessaire d'ajuster les charnières pour un meilleur alignement des portes. Servez-vous des instructions ci-dessous comme guide.

ES Puede que sea necesario ajustar los quicios de forma que se alineen las puertas. Use las instrucciones que aparecen debajo como guía.

DE Möglicherweise müssen Sie die Scharniere so einstellen, dass die Türen ausgerichtet sind. Verwenden Sie die nachstehenden Anweisungen als Leitfaden.

IT Potrebbe essere necessario regolare le cerniere in modo che le porte siano allineate. Per fare ciò attenersi alle istruzioni sottostanti.

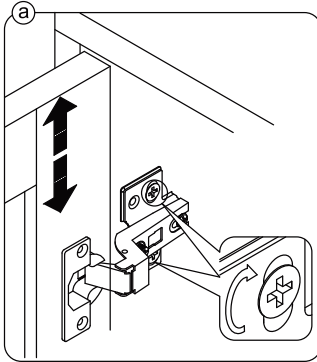

EN To adjust the door vertically loosen the screw as shown and move up and down as needed.

FR Si vous souhaitez régler la porte **verticalement**, desserrez la vis comme indiqué et déplacez la porte de haut en bas selon les besoins.

ES Para ajustar la puerta **verticalmente** afloje el tornillo tal y como se muestra y muévelo hacia arriba o hacia abajo según sea necesario.

DE Um die Tür **vertikal** auszurichten, lösen Sie die Schraube wie abgebildet und bewegen Sie sie nach Bedarf nach oben oder nach unten.

IT Per allineare la porta **verticalmente** allentare la vite come mostrato e spostarla in alto o in basso secondo necessità.

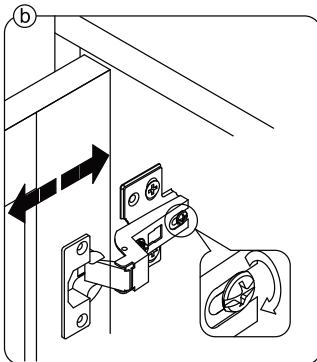

EN To adjust the gap from the door to the main frame turn the screw clockwise or anti-clockwise as needed.

FR Si vous souhaitez ajuster l'**écart** entre la porte et le cadre principal, tournez la vis dans le sens des aiguilles d'une montre ou dans le sens inverse, si nécessaire.

ES Para ajustar el **espacio** desde la puerta al marco principal, gire el tornillo en sentido horario o antihorario, según se necesite.

DE Um den **Abstand** von der Tür zum Hauptrahmen auszurichten, drehen Sie die Schraube je nach Bedarf im oder gegen den Uhrzeigersinn.

IT Per regolare lo **spazio** tra la porta e il telaio principale, avvitare o svitare la vite secondo necessità.

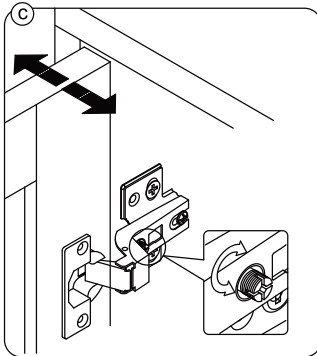

EN To adjust the door laterally adjust the screw as shown by turning clockwise or anti-clockwise.

FR Si vous souhaitez ajuster la porte **latéralement**, ajustez la vis comme indiqué en tournant dans le sens des aiguilles d'une montre ou dans le sens inverse des aiguilles d'une montre.

ES Para ajustar la puerta **lateralmente** ajuste el tornillo tal y como se muestra girándolo en sentido horario y antihorario.

DE Um die Tür **seitlich** auszurichten, stellen Sie bitte die Schraube wie abgebildet durch Drehen im oder gegen den Uhrzeigersinn ein.

IT Per allineare la porta **lateralmente** regolare la vite come mostrato, avvitandola o svitandola.

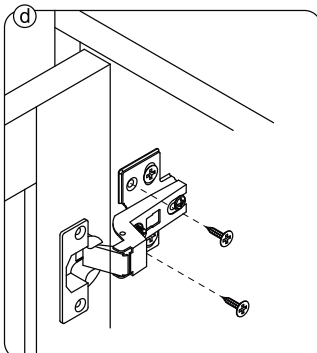

EN Please fix other screws

FR Merci de serrer les autres vis.

ES Fije los demás tornillos

DE Befestigen Sie bitte die anderen Schrauben

IT Fissare le altre viti

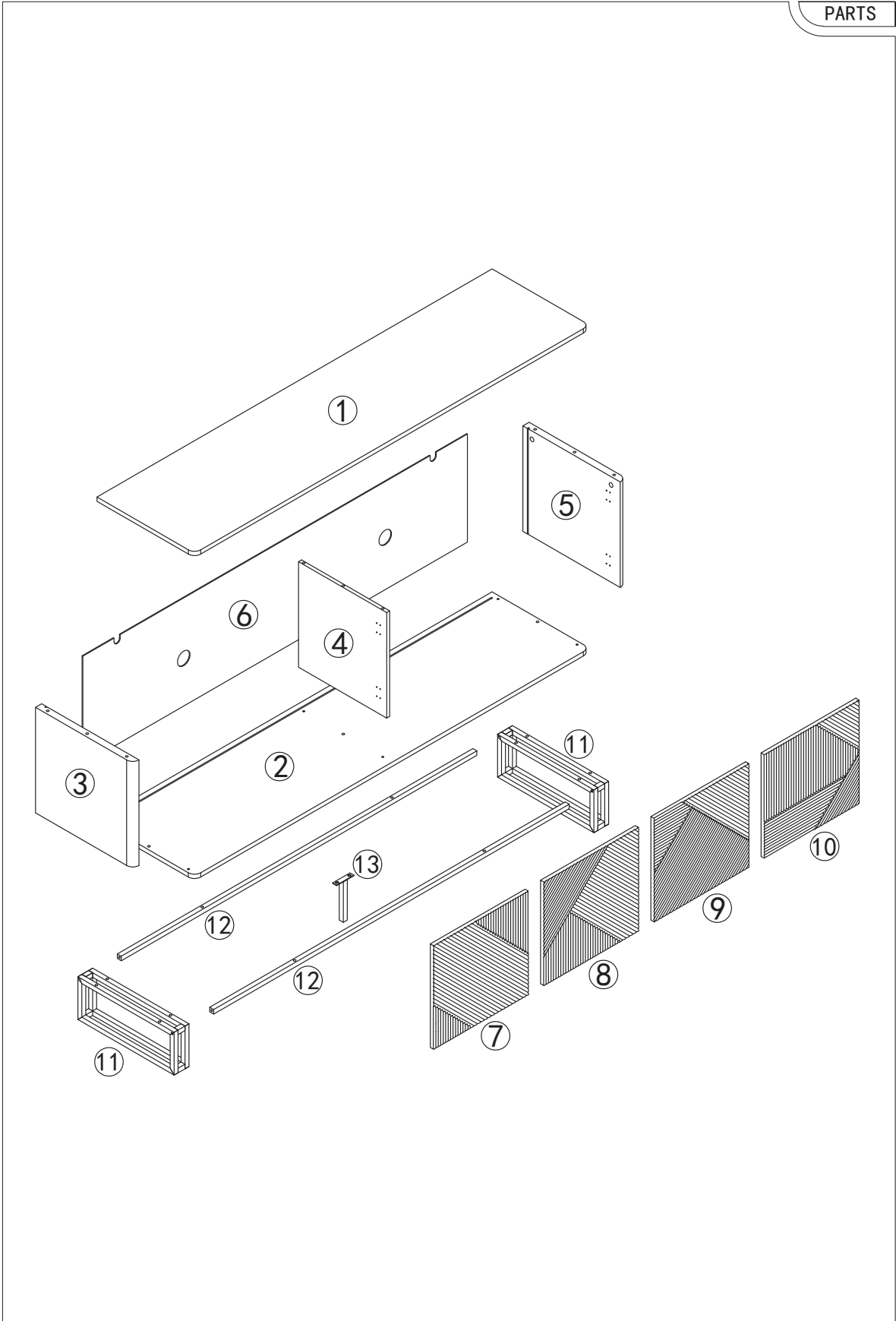

PARTS

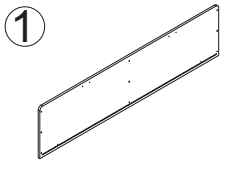
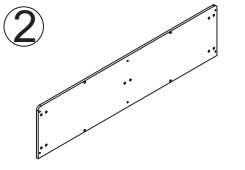
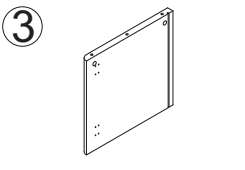
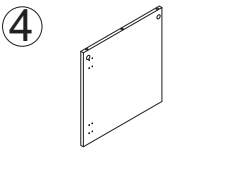
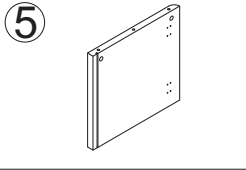
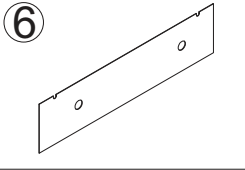
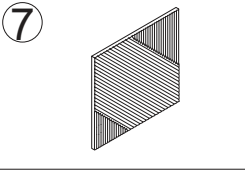
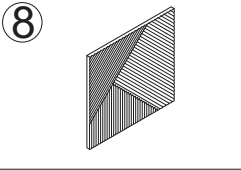
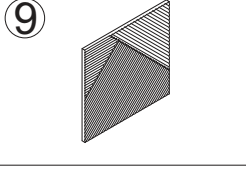
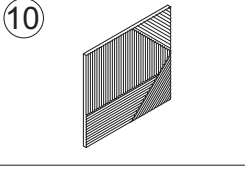
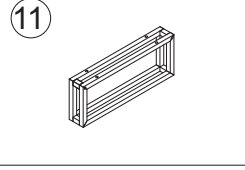
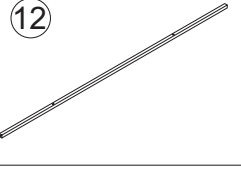
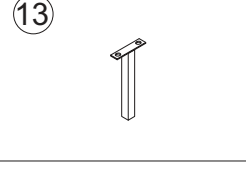

PARTS

			
1PC	1PC	1PC	1PC
			
1PC	1PC	1PC	1PC
			
1PC	1PC	2PCS	2PCS
			
1PC			

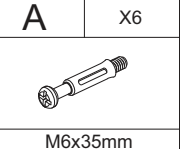
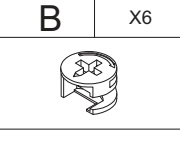
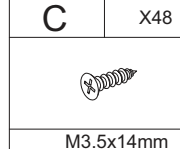
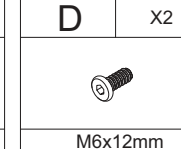
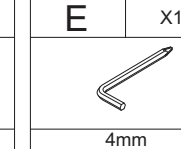
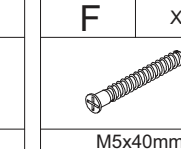
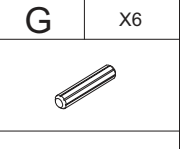
HARDWARE

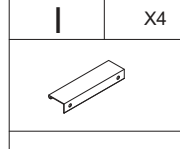
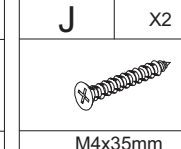
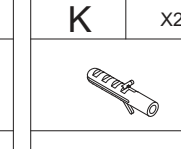
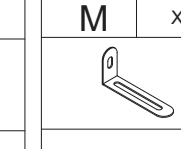
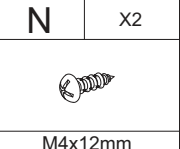
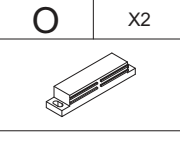
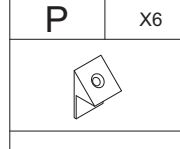
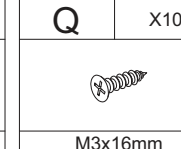
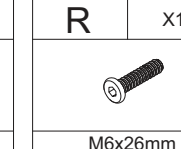
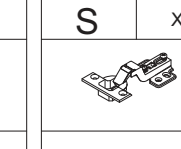
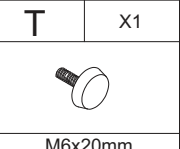
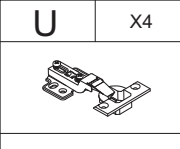
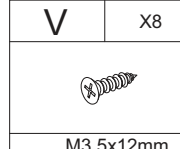
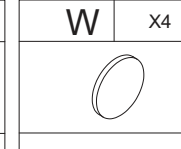
 M6x35mm	 X6	 M3.5x14mm	 M6x12mm	 4mm	 M5x40mm
 X6	 M6x80mm	 X4	 M4x35mm	 X2	 X2
 M4x12mm	 X2	 X6	 M3x16mm	 M6x26mm	 X4
 M6x20mm	 X4	 M3.5x12mm	 X4		

1

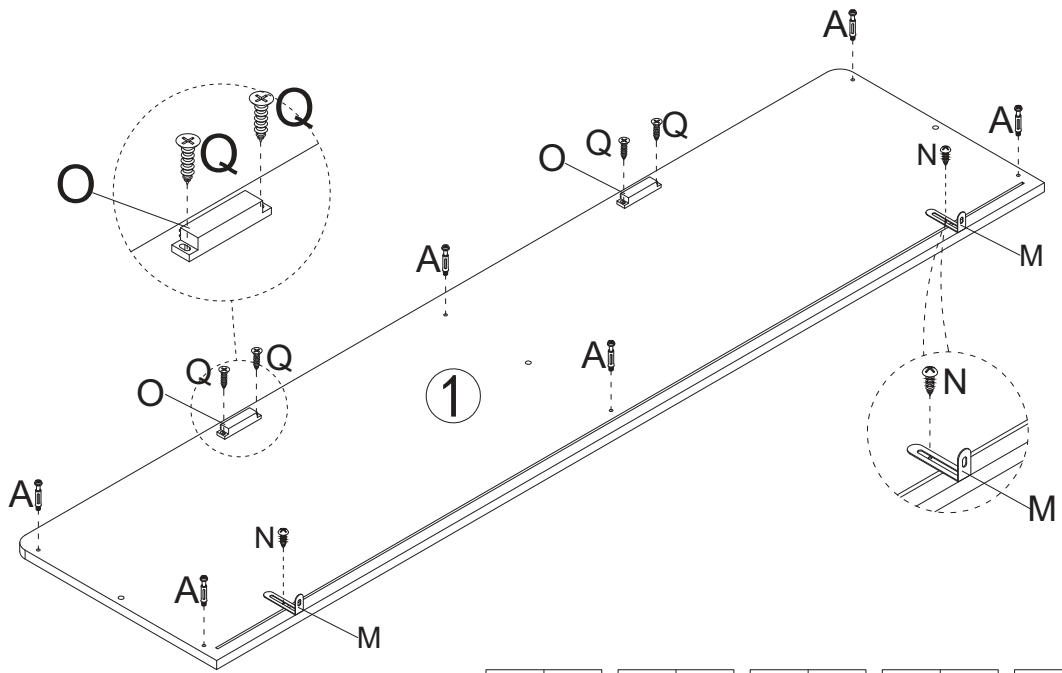

Q	X4	O	X2	A	X6	M	X2	N	X2
M3x16mm				M6x35mm				M4x12mm	

2

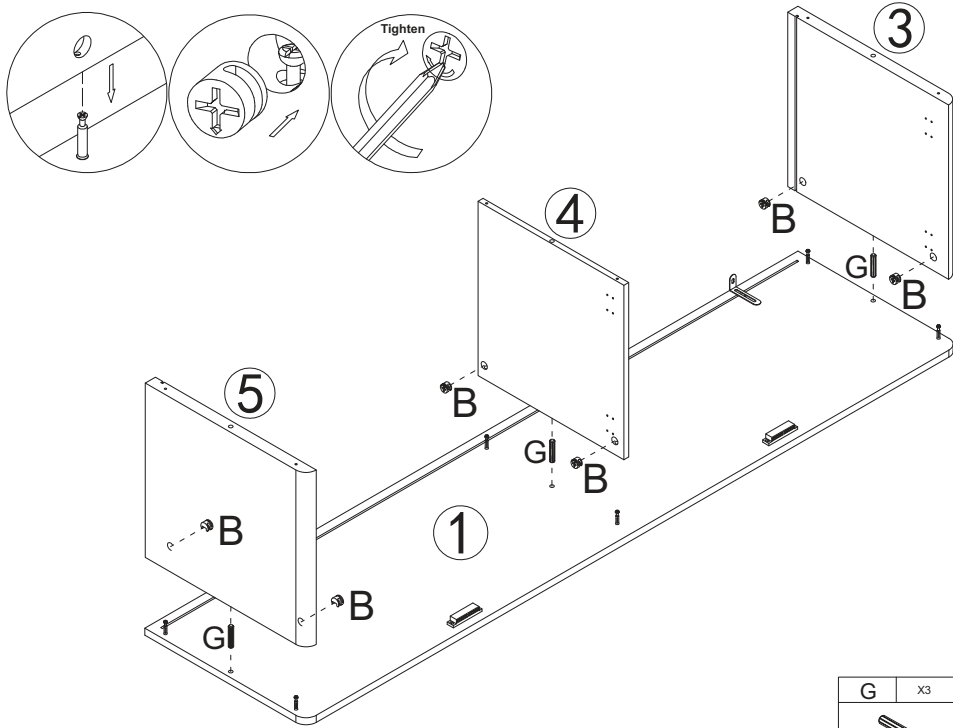

G	X3	B	X6

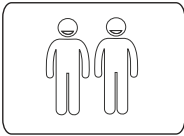

3

Requires two people to operate together.
Erfordert die Zusammenarbeit von zwei Personen.
Nécessite deux personnes pour fonctionner ensemble.

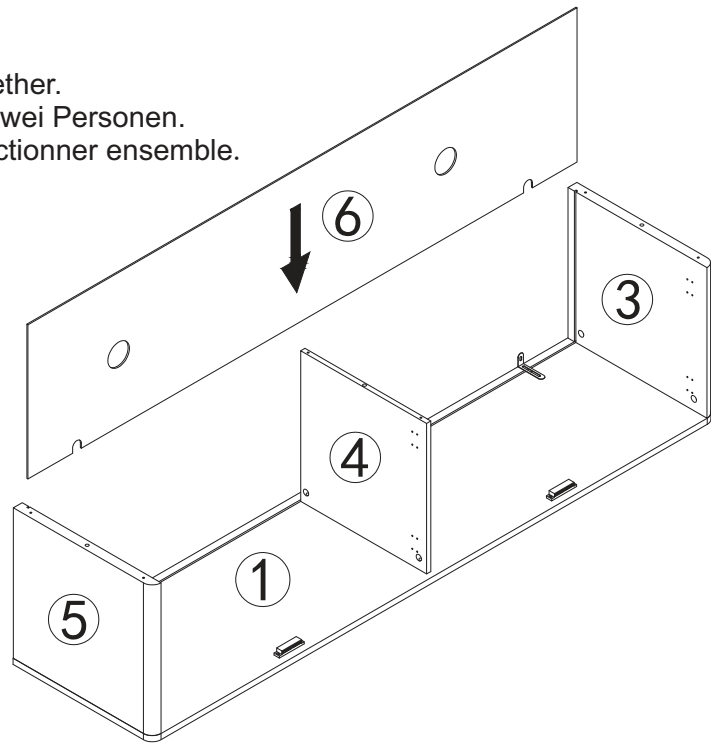

4

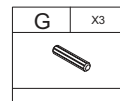
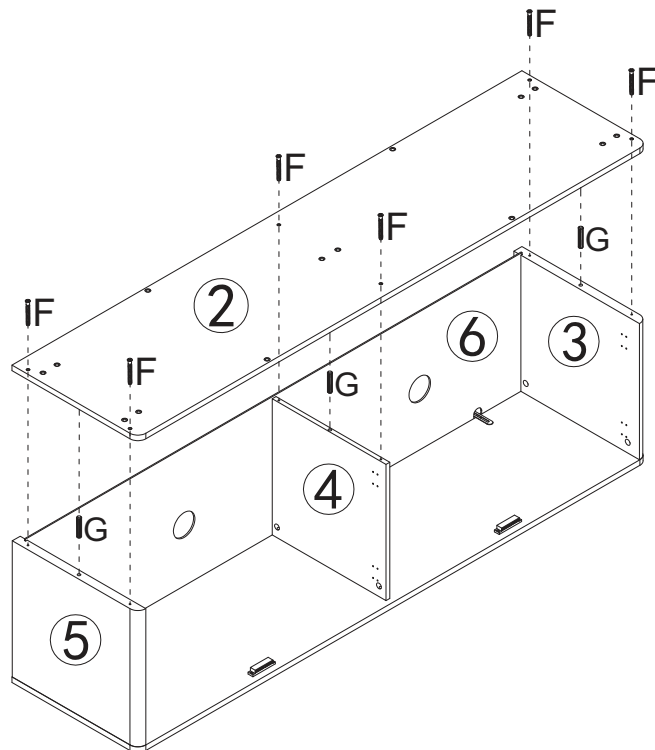

5

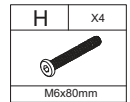
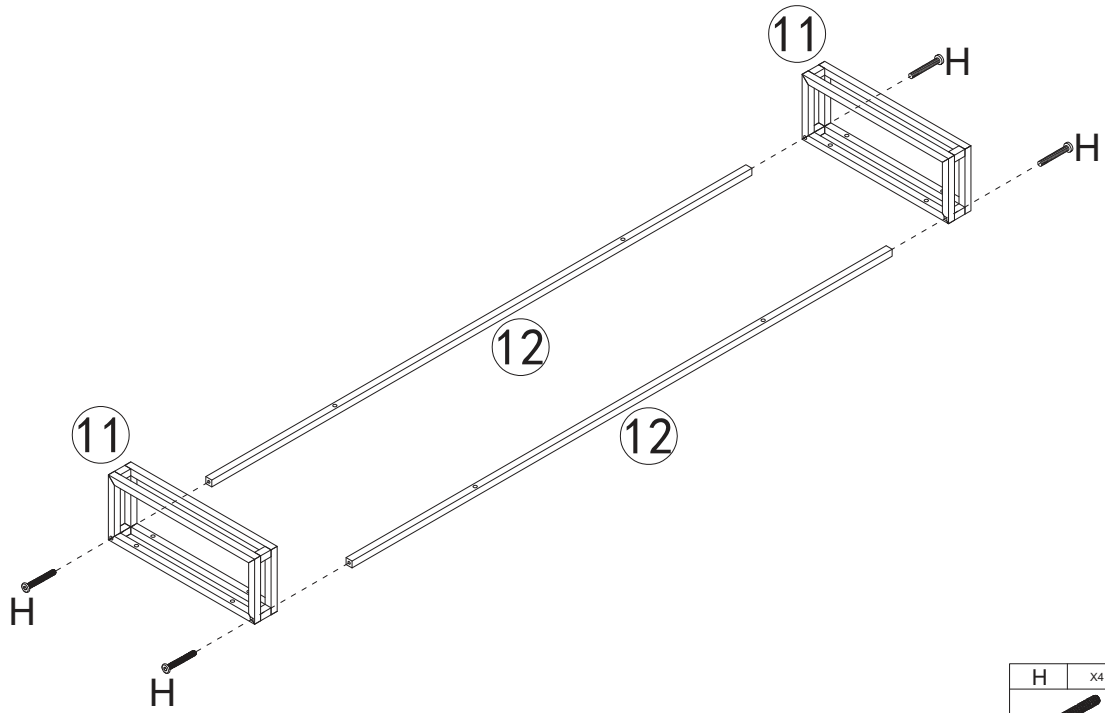

6

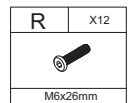
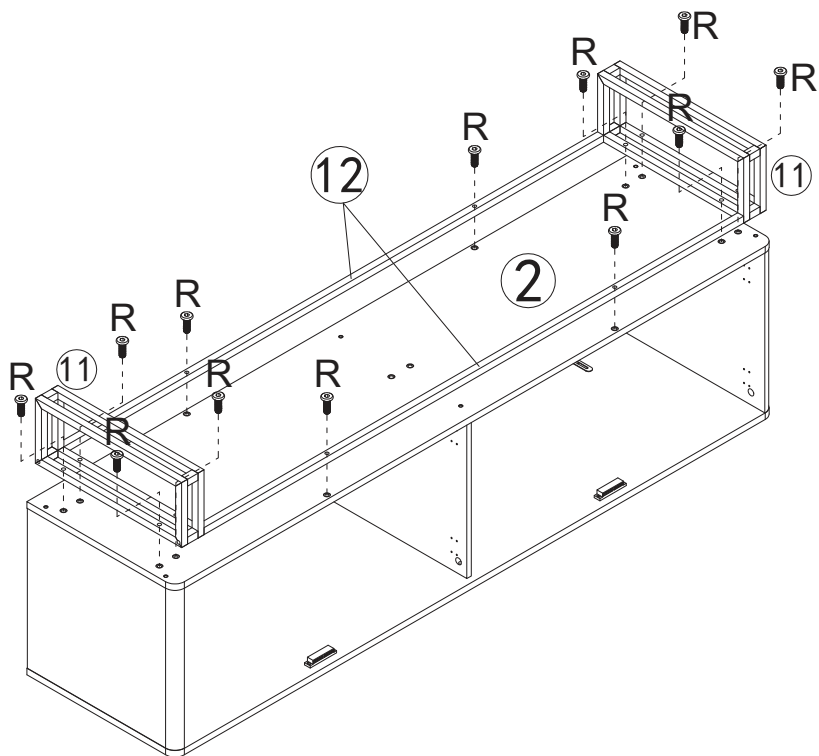

7

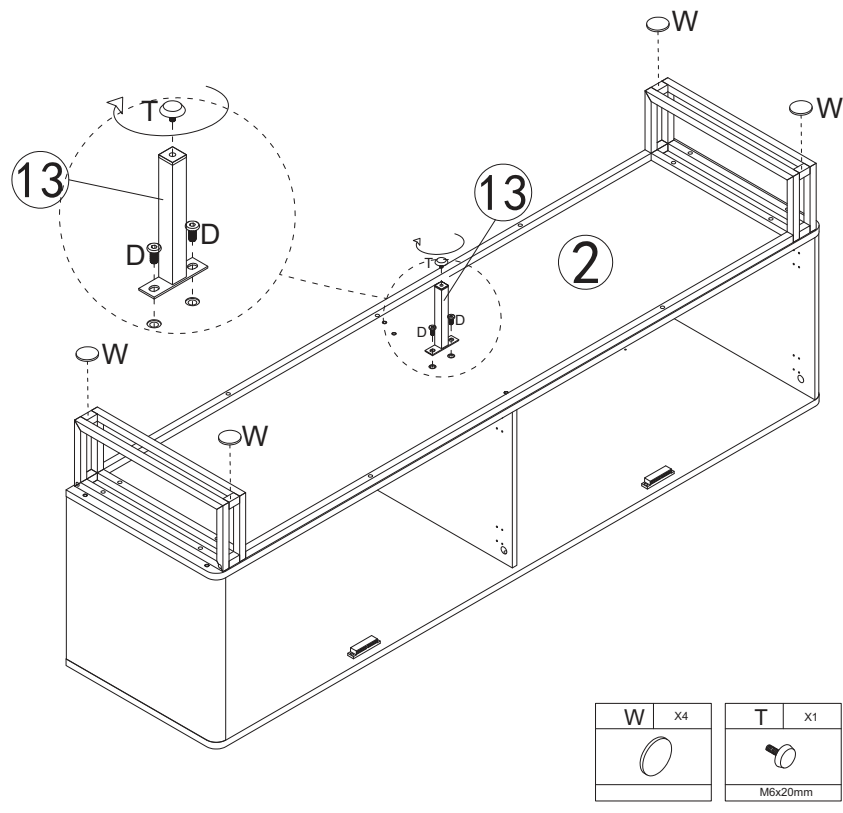

8

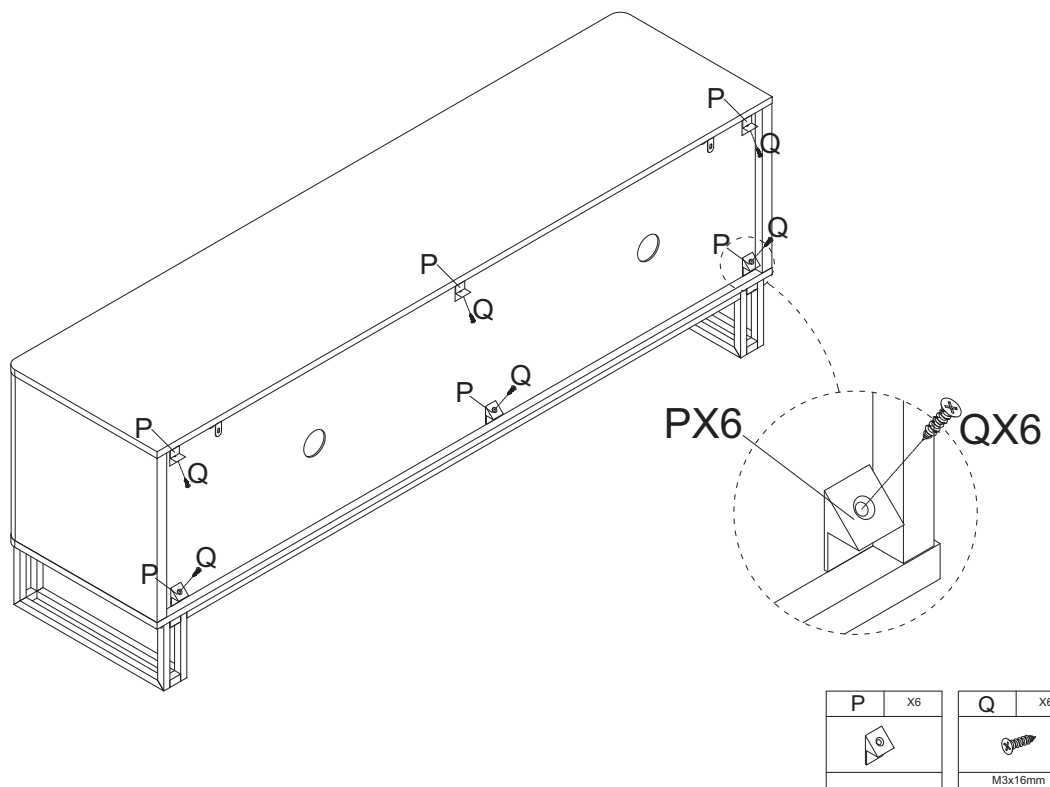

9

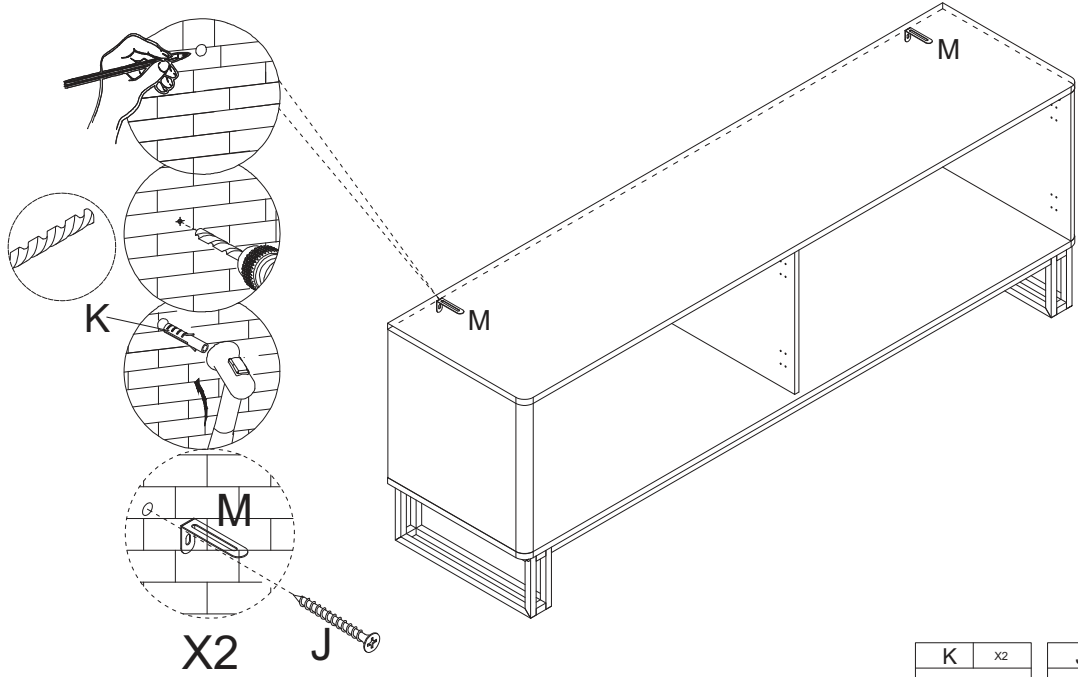

K	X2	J	X2
		M4x35mm	

10

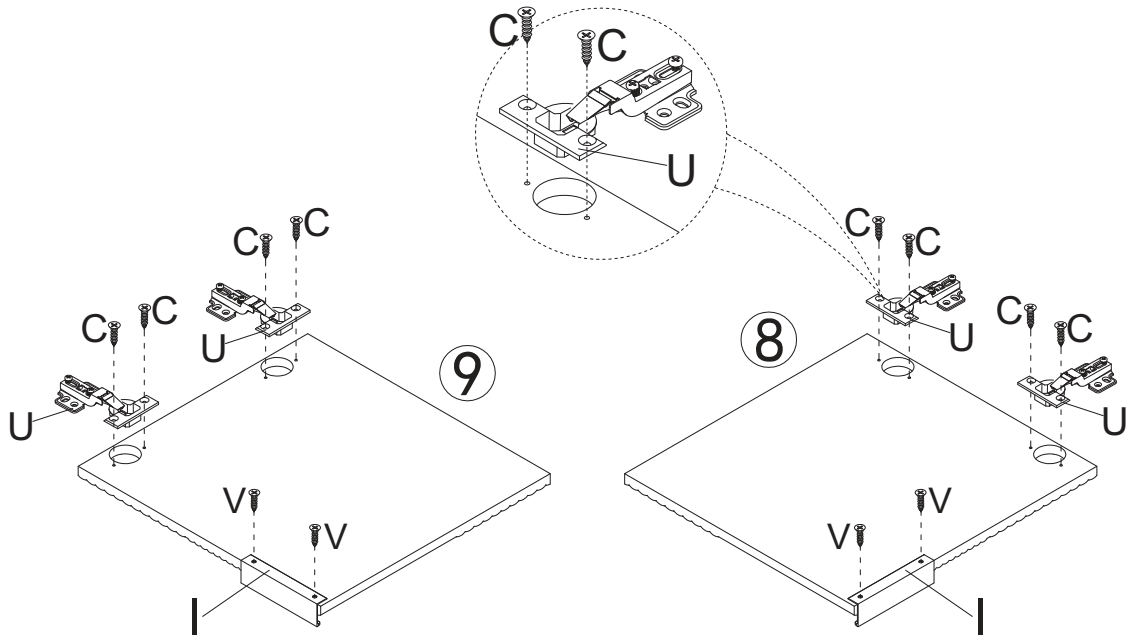

V	X4	U	X4	I	X2	C	X8
M3.5x12mm						M3.5x14mm	

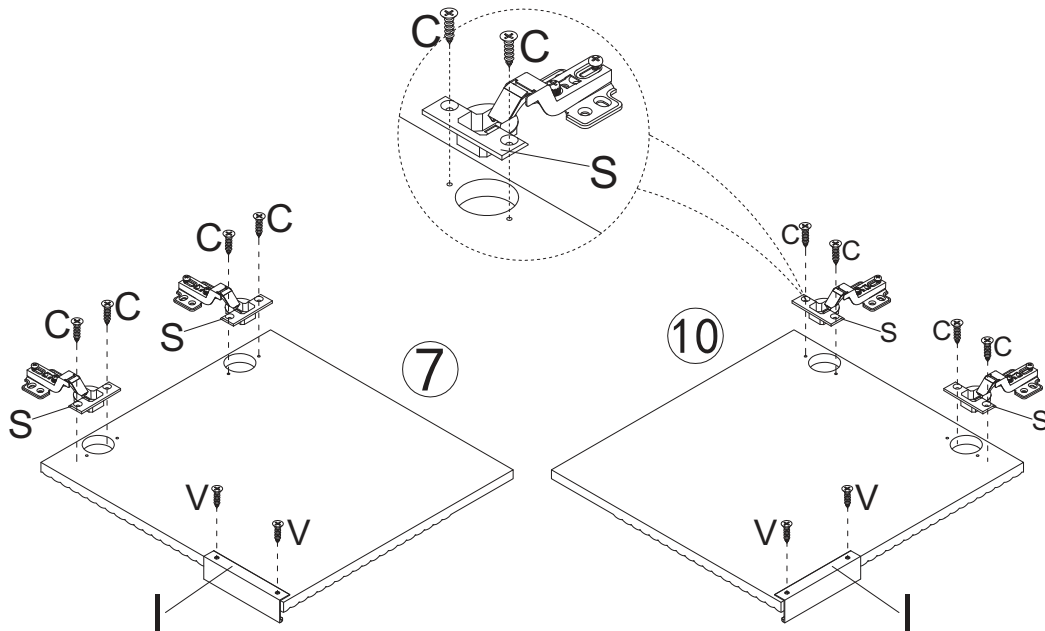

V	X4	I	X2	S	X4	C	X8
M3.5x12mm						M3.5x14mm	

Note: It is forbidden to install the fixing hole screws first, otherwise it will lead to installation failure!

Remarque : Il est interdit d'installer d'abord les vis du trou de fixation, sinon cela entraînera un échec de l'installation !

Hinweis: Es ist verboten, zuerst die Befestigungslochschauben zu montieren, da dies sonst zu einem Installationsfehler führt!

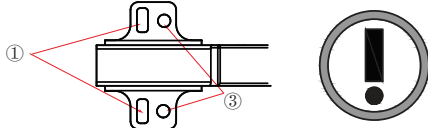

- ① Installez d'abord les vis du trou de réglage
- ② Mettez la porte dans la bonne position
- ③ Montieren Sie abschließend die Befestigungslochschauben

- ① Install the adjustment hole screws first
- ② Get the door in the right position
- ③ Finally, install the fixing hole screws

- ① Montieren Sie zuerst die Einstellochschauben
- ② Bringen Sie die Tür in die richtige Position
- ③ Enfin, installez les vis du trou de fixation

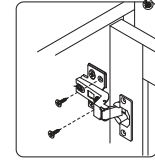
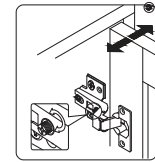
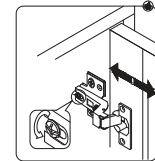
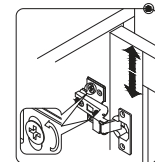
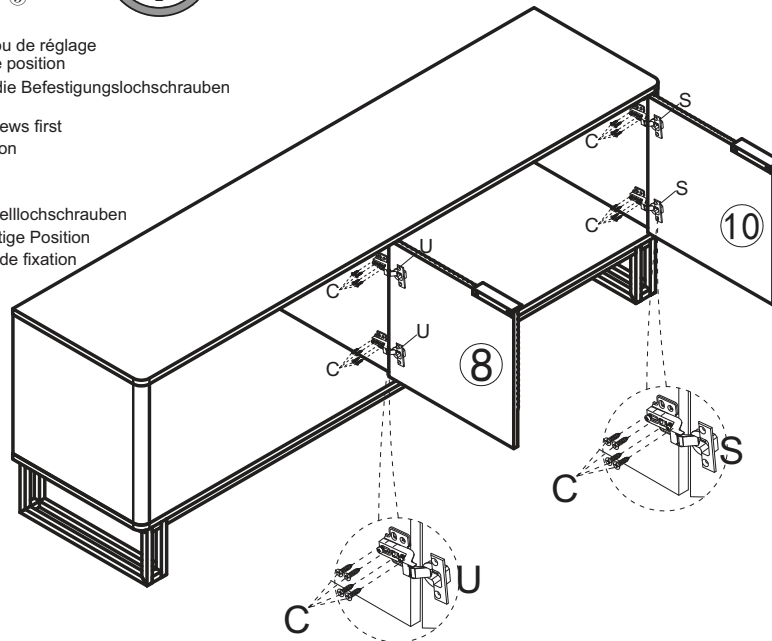

C	X16
M3.5x14mm	

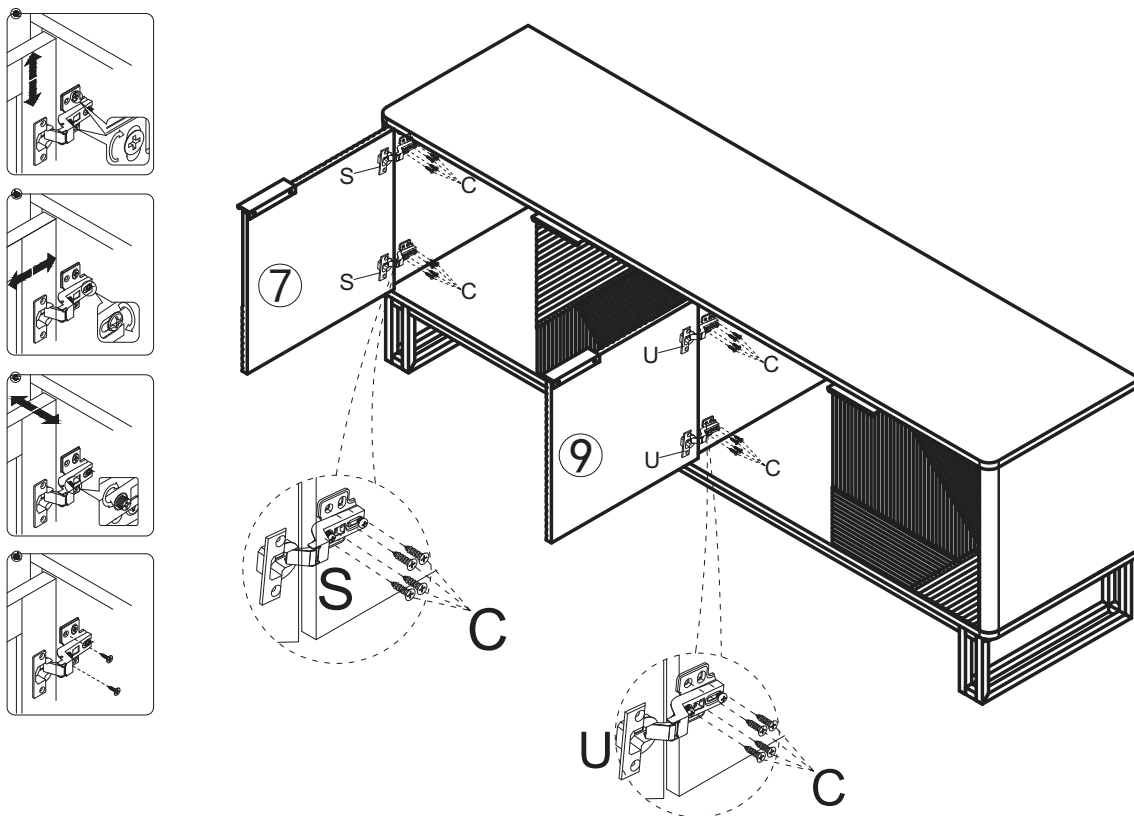

Note: It is forbidden to install the fixing hole screws first, otherwise it will lead to installation failure!

Remarque : Il est interdit d'installer d'abord les vis du trou de fixation, sinon cela entraînera un échec de l'installation !

Hinweis: Es ist verboten, zuerst die Befestigungslochschauben zu montieren, da dies sonst zu einem Installationsfehler führt!

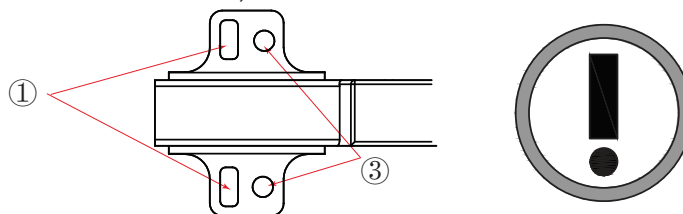

- ① Installez d'abord les vis du trou de réglage
- ② Mettez la porte dans la bonne position
- ③ Montieren Sie abschließend die Befestigungslochschauben

- ① Install the adjustment hole screws first
- ② Get the door in the right position
- ③ Finally, install the fixing hole screws

- ① Montieren Sie zuerst die Einstellochschauben
- ② Bringen Sie die Tür in die richtige Position
- ③ Enfin, installez les vis du trou de fixation

C	X16
	
M3,5x14mm	