

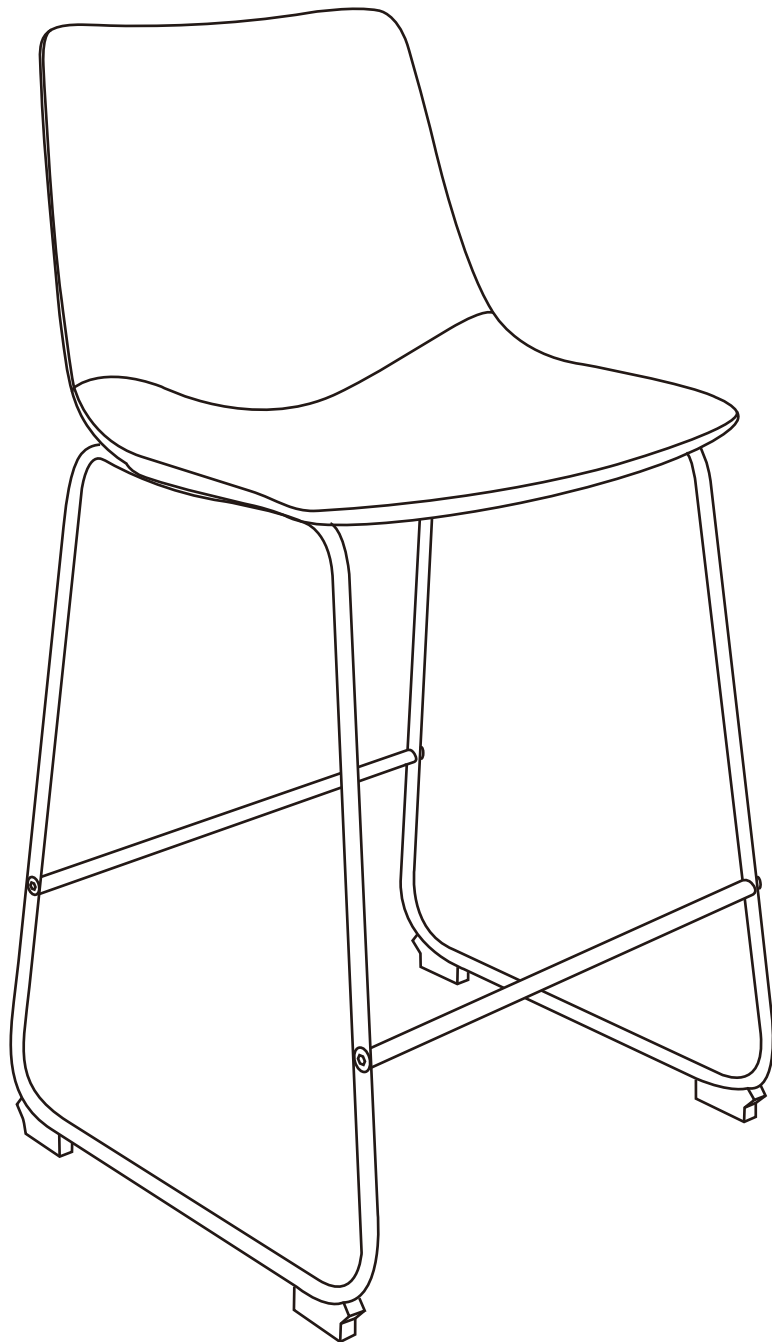





# ASSEMBLY INSTRUCTION

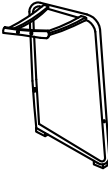

# Component List

LABEL		DESCRIPTION	QTY
A		Seat	1
B		Leg A	1
C		Leg A	1
D		Metal Connector	2

# Hardware List

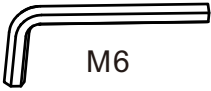
E	 M6*30MM	Bolts A	4
F	 M8*14MM	Bolts B	2
G	 M6*22MM	Bolts C	4
H	 M6	Allen Wrench	1

1

Fx2pcs



M8\*14MM

Hx1pc



M6



H

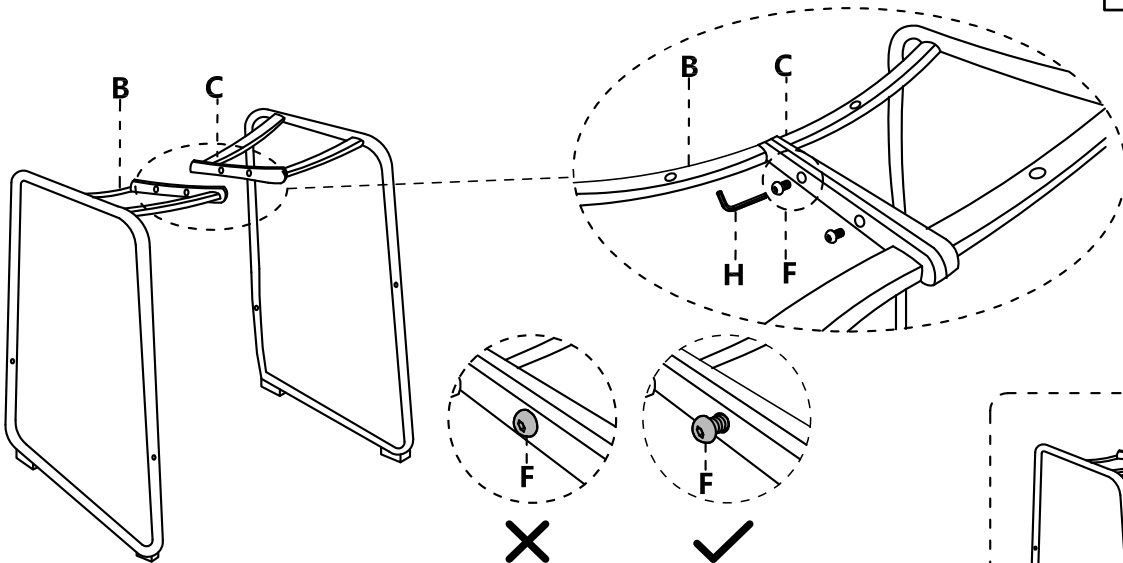

Only Screw F in 50%.

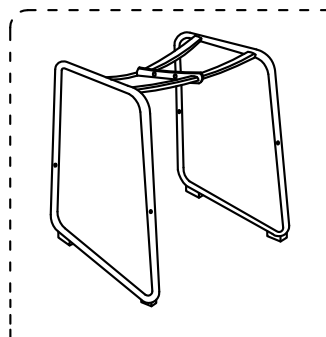

2

Ex4pcs



M6\*30MM

Hx1pc



M6



H

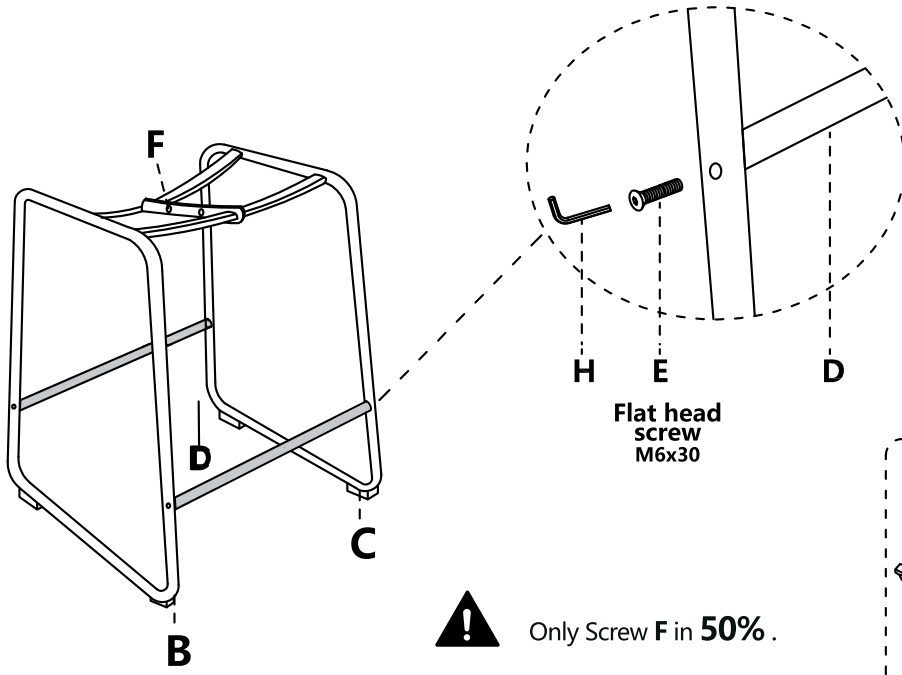

Only Screw F in 50%.

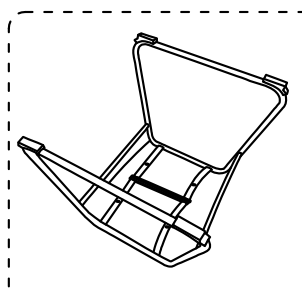

3

Gx4pcs



M6\*22MM

Hx1pc



M6

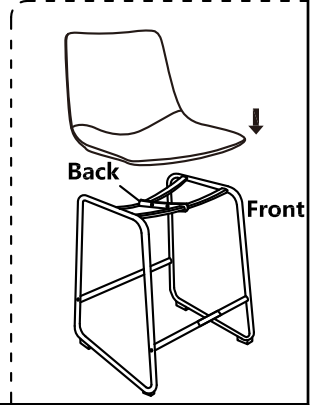
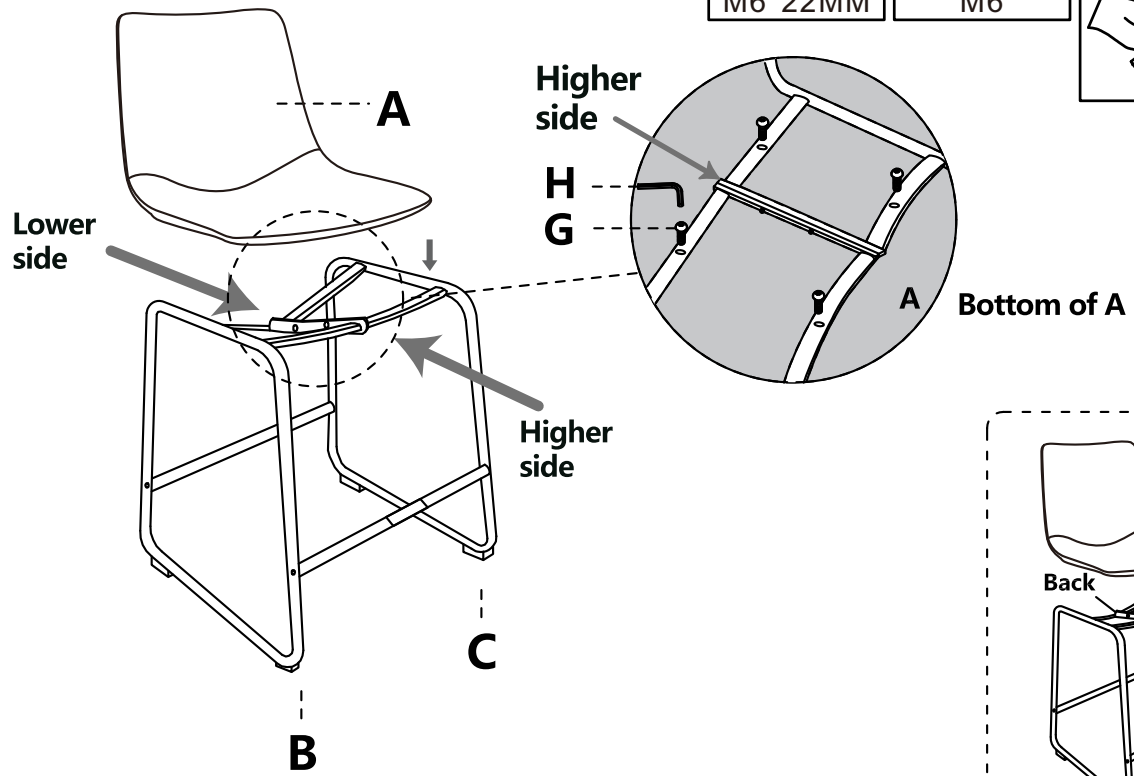
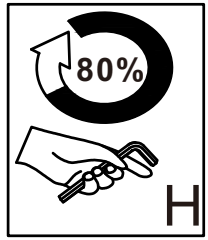

4

