

# 13X20ft Garden Metal Garage Shed/Abri de garage en métal pour jardin

Item/Article #: A110006612

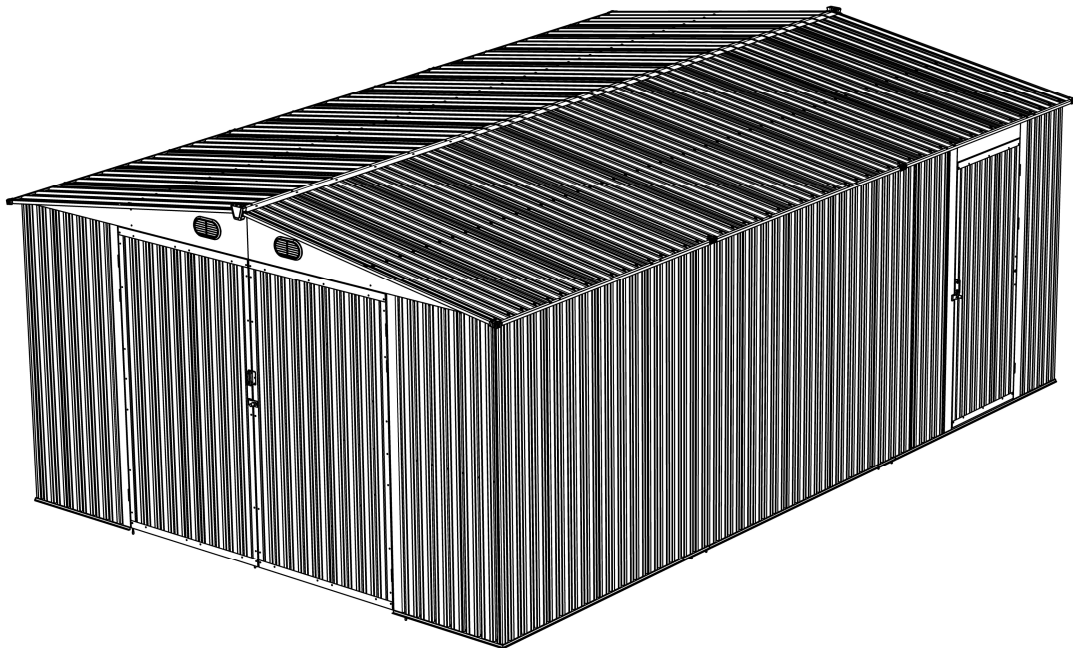

***Questions? Issues? Missing Part? Professional  
Installation Service?***

***Contact us at [customer.care@sunjoygroup.com](mailto:customer.care@sunjoygroup.com)***

***Questions? Problèmes? Pièce manquante? Service  
d'installation professionnel?***

***Contactez-nous à [customer.care@sunjoygroup.com](mailto:customer.care@sunjoygroup.com)***



A11000661225



Country of Origin: China  
Pais d'origine: Chine

Production Number: 2025101116  
Numéro de fabrication: 2025101116

## Site Selection/Sélection du site

Avoid overhanging trees as much as possible as leaves will make regular cleaning necessary and broken branches are a potential hazard. | Small trees, bushes or fences nearby can be helpful, acting as a wind break.

Évitez autant que possible les arbres en surplomb car les feuilles formeront des arbres réguliers. le nettoyage nécessaire et les branches cassées constituent un danger potentiel. | Petit les arbres, les buissons ou les clôtures à proximité peuvent être utiles, agissant comme brise-vent.

## Site Preparation /Préparation du chantier

The site must be prepared so that the base of the shed is level all round and checking with a spirit level is required. The base can be constructed by treated timber or concrete, in order to stop the moisture getting into the shed. The shed is not designed to be built onto lawn directly. Also the ground will get muddy during rainy days. If a concrete pad is made, it is important that this slopes towards the edges to prevent water ingress. Time must be allowed for any concrete or cement to dry before building the shed on top. Bases can also be constructed from bricks, blocks, or mounted on a concrete pad. The bricks or blocks should be cemented onto firm and level concrete footings.

Le site doit être préparé de manière à ce que la base du hangar soit de niveau sur tout son pourtour et une vérification avec un niveau à bulle est nécessaire. La base peut être construite en bois traité ou en béton, afin d'empêcher l'humidité de pénétrer dans l'abri. L'abri n'est pas conçu pour être construit directement sur la pelouse. De plus, le sol deviendra boueux pendant les jours de pluie. Si une dalle en béton est réalisée, il est important qu'elle soit inclinée vers les bords pour empêcher l'infiltration d'eau. Il faut laisser le temps au béton ou au ciment de sécher avant de construire le hangar par-dessus. Les bases peuvent également être construites à partir de briques, de blocs ou montées sur une dalle de béton. Les briques ou blocs doivent être cimentés sur des semelles en béton fermes et

**Please prepare below tools before installation. (Not Included)**  
**Veillez préparer les outils ci-dessous avant l'installation. (Non inclus)**



Electric Screwdriver  
Visseuse électrique



+ Manual Screwdriver  
Tournevis manuel



Ladder/Échelle



Spanner/Clé

**Package included Tools**  
**Emballage inclus Outils**



Gloves X 1 Pair  
Gants X 1 paire

## **ATTENTION:**

1. Please read this instruction carefully before installation and follow it strictly during installation. / Veuillez lire attentivement ces instructions avant l'installation et les suivre strictement pendant l'installation.

2. Ensure that there are no problems later due to installation errors. / Assurez-vous qu'il n'y aura aucun problème ultérieur dû à des erreurs d'installation.

3. We have prepared extra screws for you to use in case of loss or damage. / Nous avons préparé des vis supplémentaires que vous pourrez utiliser en cas de perte ou de dommage.

### **Installation Notes/Notes d'installation**

Please check the quantity of all parts before installation (refer to the Parts Lists) and the appearance of the products. Make sure the product is correct before installation. / Veuillez vérifier la quantité de toutes les pièces avant l'installation (voir les listes de pièces) et l'apparence des produits. Assurez-vous que le produit est correct avant l'installation.

Make sure the colored panels are facing outwards and all the holes match. The panels are textured, please install the panels in the order specified in the instructions. All lines and holes should be matched to make the storage shed more stable. Please ensure that all screws are tightened to prevent the product from falling apart. / Assurez-vous que les panneaux colorés sont orientés vers l'extérieur et que tous les trous correspondent. Les panneaux sont texturés, veuillez installer les panneaux dans l'ordre spécifié dans les instructions. Toutes les lignes et tous les trous doivent être assortis pour rendre le hangar de stockage plus stable. Veuillez vous assurer que toutes les vis sont serrées pour éviter que le produit ne s'effondre.

There is a protective film on the surface to protect the product, you can tear it off after installation. If you do not damage the film during installation, it can also remain on the product to protect. / Il y a un film protecteur sur la surface pour protéger le produit, vous pouvez l'arracher après l'installation. Si vous n'endommagez pas le film lors de la pose, il peut également rester sur le produit pour le protéger.

Please place the product on a flat ground to prevent leaning and collapse. If the ground is uneven, the door may can't be closed. / Veuillez placer le produit sur un sol plat pour éviter qu'il ne s'incline et ne s'effondre. Si le sol est irrégulier, la porte ne peut pas être fermée.



### **Safety Precautions /Précautions de sécurité**

We recommend two adults to complete the installation. Two adults installed together will make the installation process easier and safer. / Nous recommandons que deux adultes terminent l'installation. Deux adultes installés ensemble rendront le processus d'installation plus facile et plus sûr.











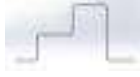



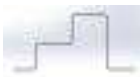

The gloves must be carried to prevent hand cuts during installation. / Les gants doivent être portés pour éviter les coupures aux mains lors de l'installation.











Take care when using power tools near water the use of a residual current device (RCD) is advised. / Soyez prudent lorsque vous utilisez des outils électriques à proximité de l'eau, l'utilisation d'un dispositif à courant résiduel (RCD) est conseillée.

















Please use the electric driver carefully during screwing to prevent the screw from slipping and hurting your hand. / Veuillez utiliser le tournevis électrique avec précaution pendant le vissage pour éviter que la vis ne glisse et ne vous blesse la main.





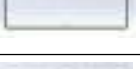
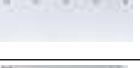











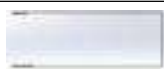

Be careful not to fall when installing the roof. Please steady the ladder and make sure the product placed on a flat ground. / Faites attention à ne pas tomber lors de l'installation du toit. Veuillez stabiliser l'échelle et vous assurer que le produit est placé sur un sol plat.











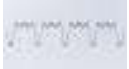



**PLEASE KEEP THIS INSTRUCTION FOR FUTURE REFERENCE.  
VEUILLEZ CONSERVER CETTE INSTRUCTION POUR RÉFÉRENCE FUTURE.**









<b>Parts List/Liste de Pièces</b>			
<b>Label Étiquette</b>	<b>Part Number Numéro de la Pièce</b>	<b>Qty Quantité</b>	<b>Part Image Image de la pièce</b>
4L	P00010061203	1	
4R	P00010061303	1	
1L	P00010061403	2	
1R	P00010061503	1	
2	P00010061603	1	
3	P00010061703	1	
1M	P00010061803	2	
P1	P00070161003	4	
P2	P00380078303	28	
P4	P00070161203	2	
P3	P00070161103	2	
13L	P00450006703	1	
13R	P00450006803	1	
8	P00570048503	1	
7	P00570048403	1	
A1	P00050240003	1	
10R	P00450006403	2	
12L	P00450006503	1	







12R	P00450006603	1	
15L	P00450006903	1	
15R	P00450007003	1	
16	P00010061903	1	
10M	P00450007103	2	
11M	P00060328203	2	
17	P00450007203	1	
18	P00060328303	1	
19	P00060328403	1	
20	P00500099103	2	
21	P00500099203	4	
15M	P00450007303	1	
22L	P00060328503	1	
22R	P00060328603	1	
14	P00220054903	4	
23	P00060328703	2	
24	P00220055003	2	
ABL	P00040185003	2	
ABR	P00040185103	2	

ABM	P00040185203	2	
AP6	P00040185303	4	
AP7	P00040185403	4	
AP8	P00040185503	2	
C2	P00500099303	2	
C3	P00500099403	2	
CL	P00500099503	2	
CR	P00500099603	2	
CM	P00500099703	2	
C4	P00500099803	4	
D1	P00410024903	2	
D2	P00410025003	4	
D3	P00410025103	2	
D4	P00410025203	2	
D5	P00410025303	1	
D6	P00410025403	1	
D7	P00410025503	4	
D8	P00410025603	4	
D9	P00410025703	3	

D10	P00410025803	4	
10L	P00450007403	1	
11L	P00060328803	2	
11R	P00060328903	1	
9L	P00060329003	1	
9R	P00060329103	1	
D16	P00410026403	1	
D17	P00410026503	1	
D18	P00410026603	2	
D19	P00410026703	1	
D20	P00410026803	2	
D21	P00410026903	1	
E1	P00560065803	2	
E2	P00560065903	4	
E3	P00560066003	4	
E4	P00050240203	4	
E5	P00050240303	5	
APL	P00500100503	2	
APR	P00500100603	2	

PL	P00500100703	4	
AP2	P00070161503	26	
AP5	P00090024003	3	
E6	P00560066103	4	
E7	P00050240403	4	
E8	P00060329203	4	
E9	P00050240503	26	
E11	P00050240603	4	
E10	P00050240703	2	
E12	P00060329303	4	
D11	P00410025903	1	
D12	P00410026003	2	
D13	P00410026103	1	
D14	P00410026203	1	
D15	P00410026303	1	

Hardware Pack/Pack Quincaillerie					
Label	Part Number Numéro de la Pièce	Description	Qty Quantité	Add	Part Image Image de la pièce
F4	H030070017	Screw ST3.5*9.5 / Vis ST3.5*9.5	20	2	
F1	H030070943	Screw ST4.8*13 / Vis ST4.8*13	996	70	
F6	H040010021	Hex Nut M5/ Écrou hexagonal M5	230	20	
F2	H010110076	Bolt M5*12 Boulon M5*12	158	8	
F13	H010110055	Bolt M5*25 Boulon M5*25	60	5	
F12	H010070028	Bolt M8*35 Boulon M8*35	6	1	
F16	H010110093	Bolt M5*40 Boulon M5*40	12	2	
F8	H990010034	Cap M5/ Bouchon M5	302	20	
F7	H990020021	Washer/ Machine à laver	761	49	
RC2	P007600302 01	Protector/ Protecteur	4	0	
RC3	P000502396 01	Connector/ Connector	4	0	
GF	P007600303 01	Exhaust/ Échappement	4	0	
RT3	P007600304 01	LOGO/LOGO	2	0	

S1	H980010007	Hinge/ Charnière	9	0	
GB	P005100432 01	Lock/ Verrouillage	2	0	
F11	H030050065	Screw ST4.2*16 / Vis ST4.2*16	66	5	
F17	H040010010	Hex Nut M8/ Écrou hexagonal M8	6	1	
GD	P005100431 01	Bolt/ Boulon	2	0	
GE	H010100006	Bolt M6*80/ Boulon M6*80	11	0	

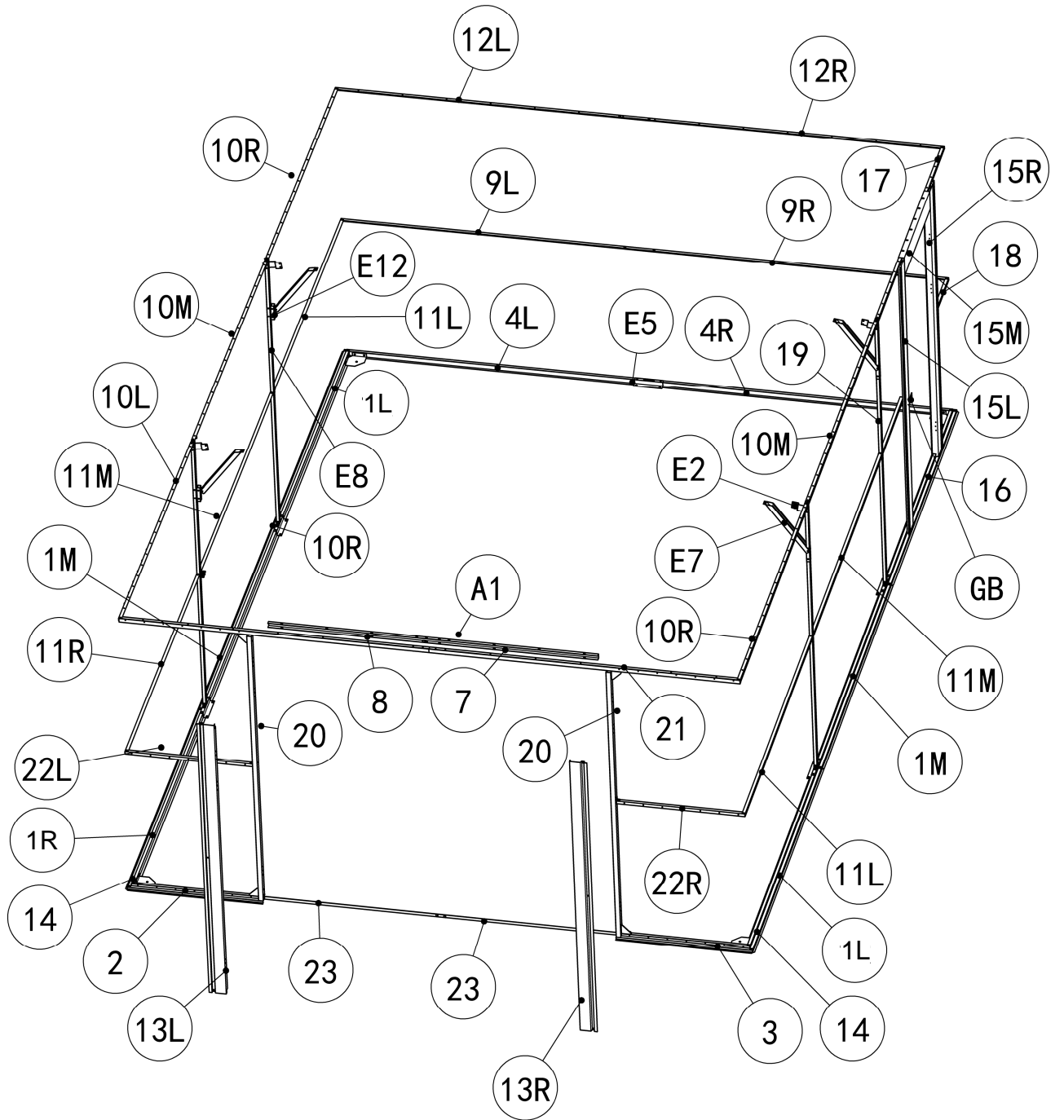



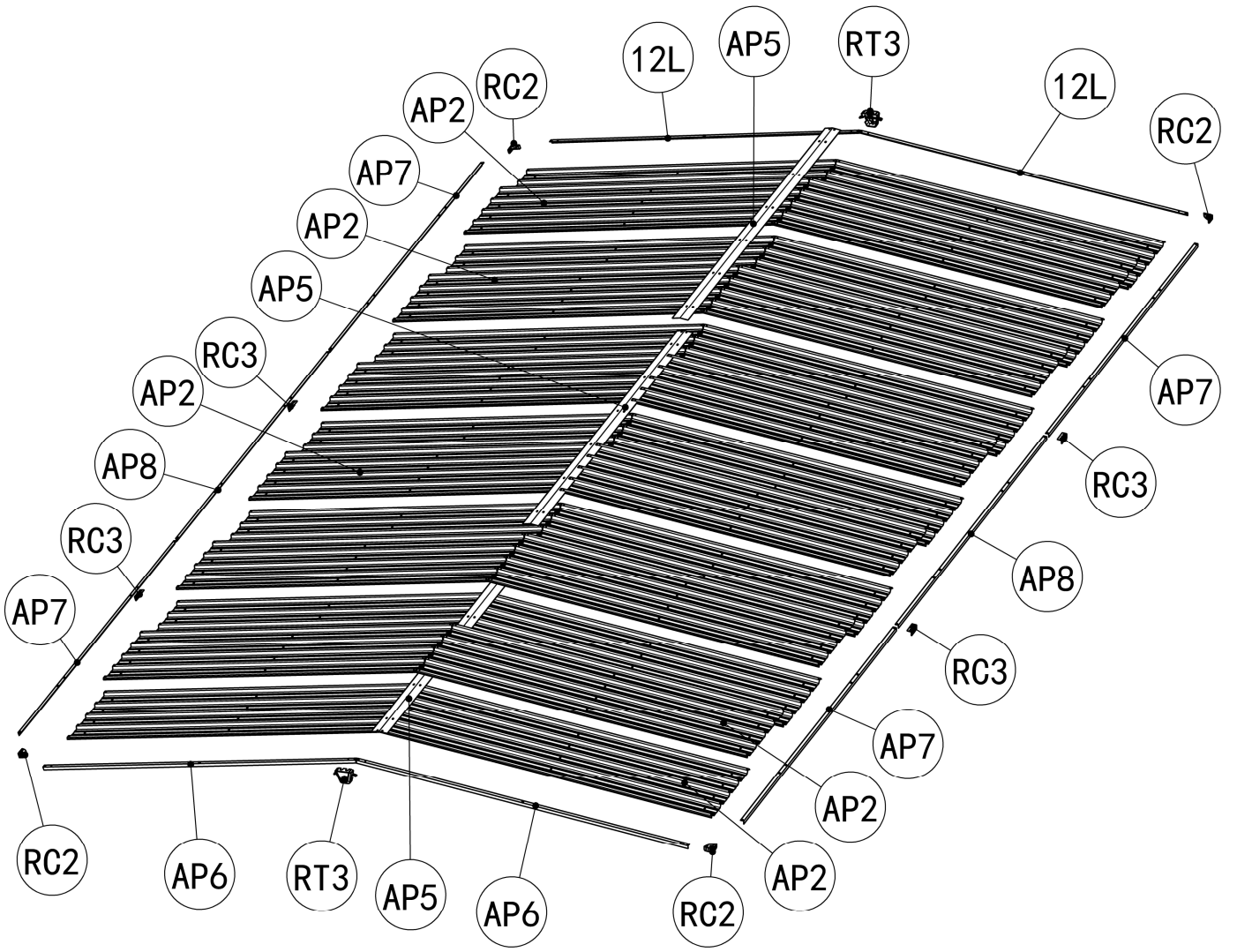

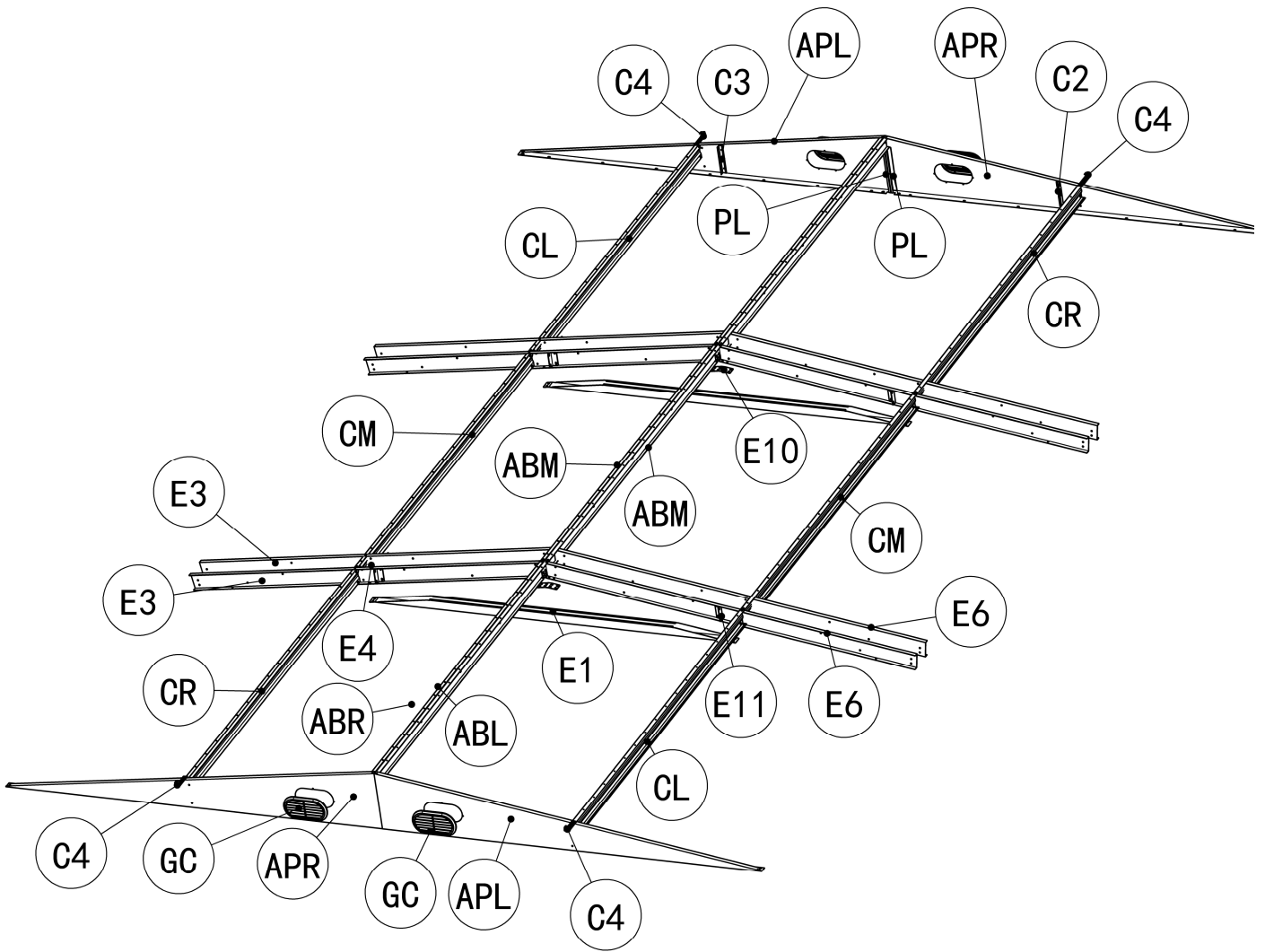

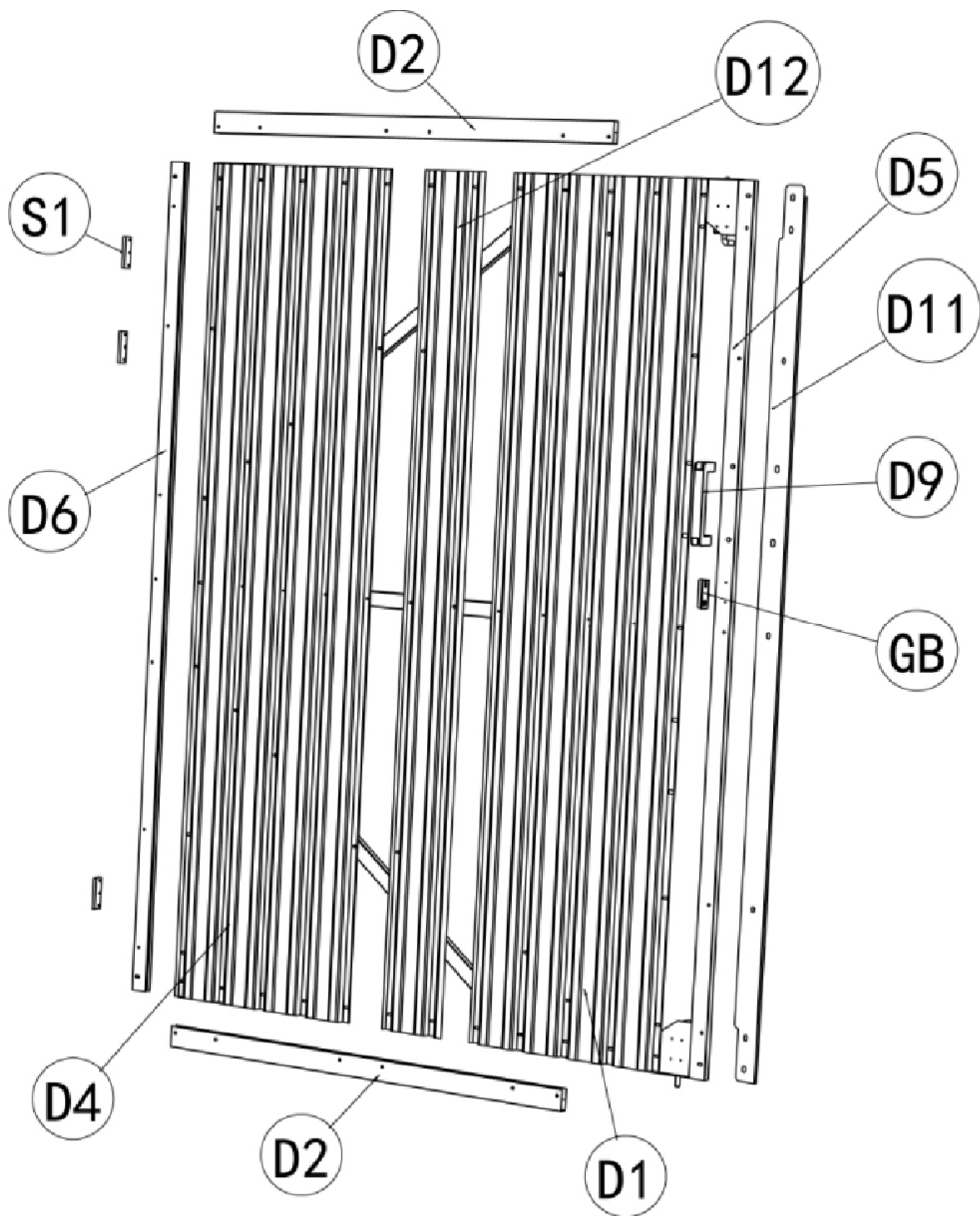

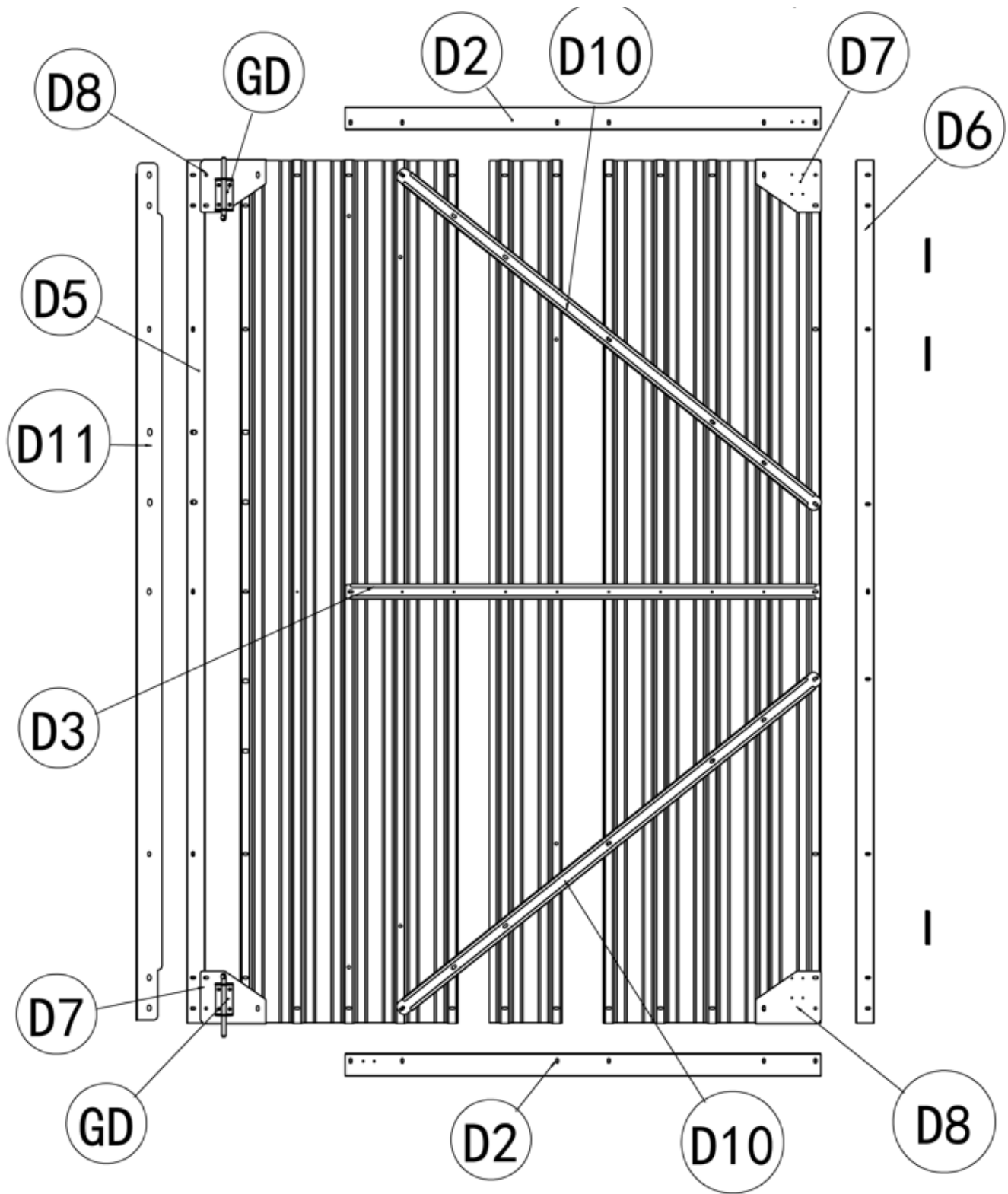

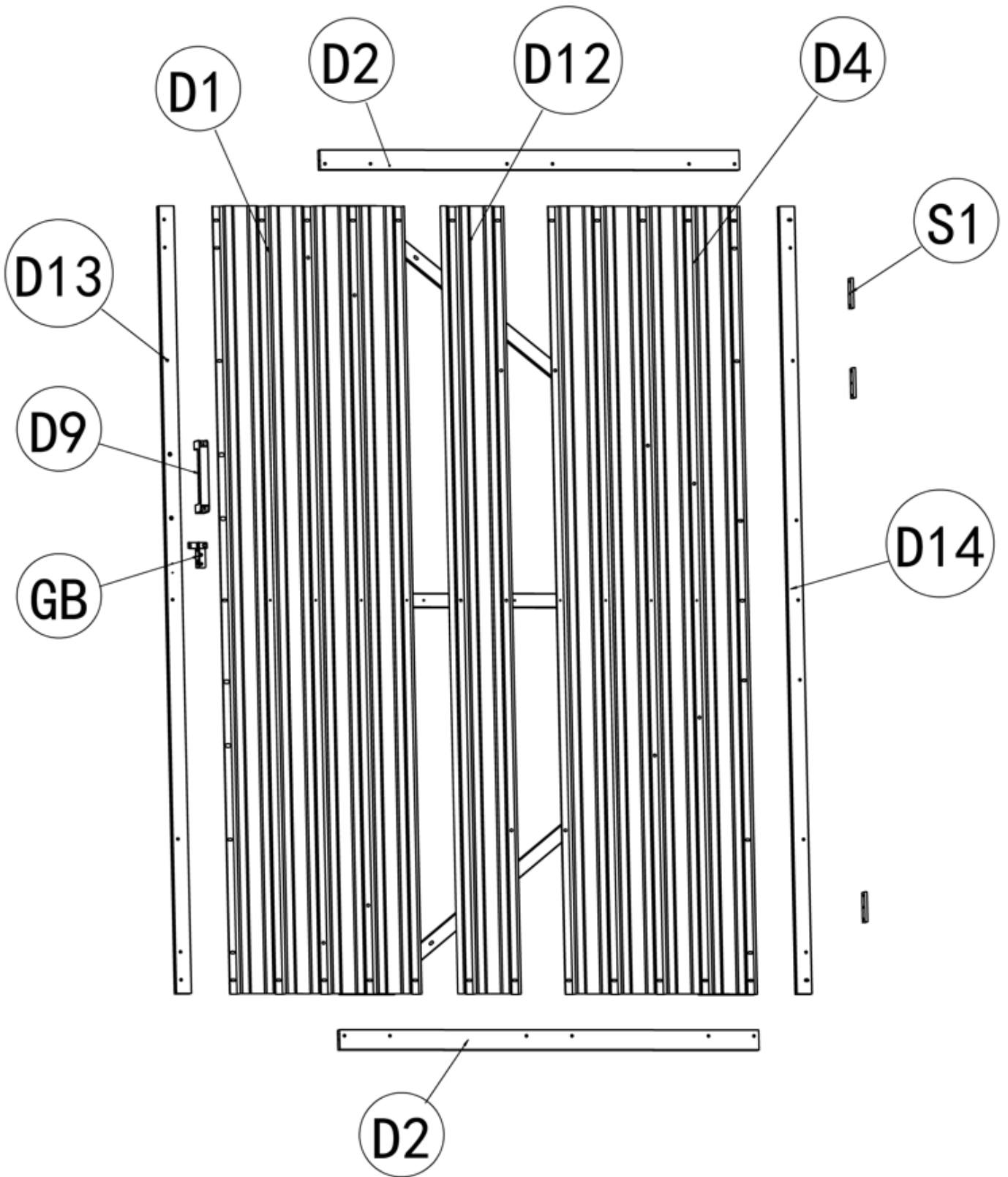

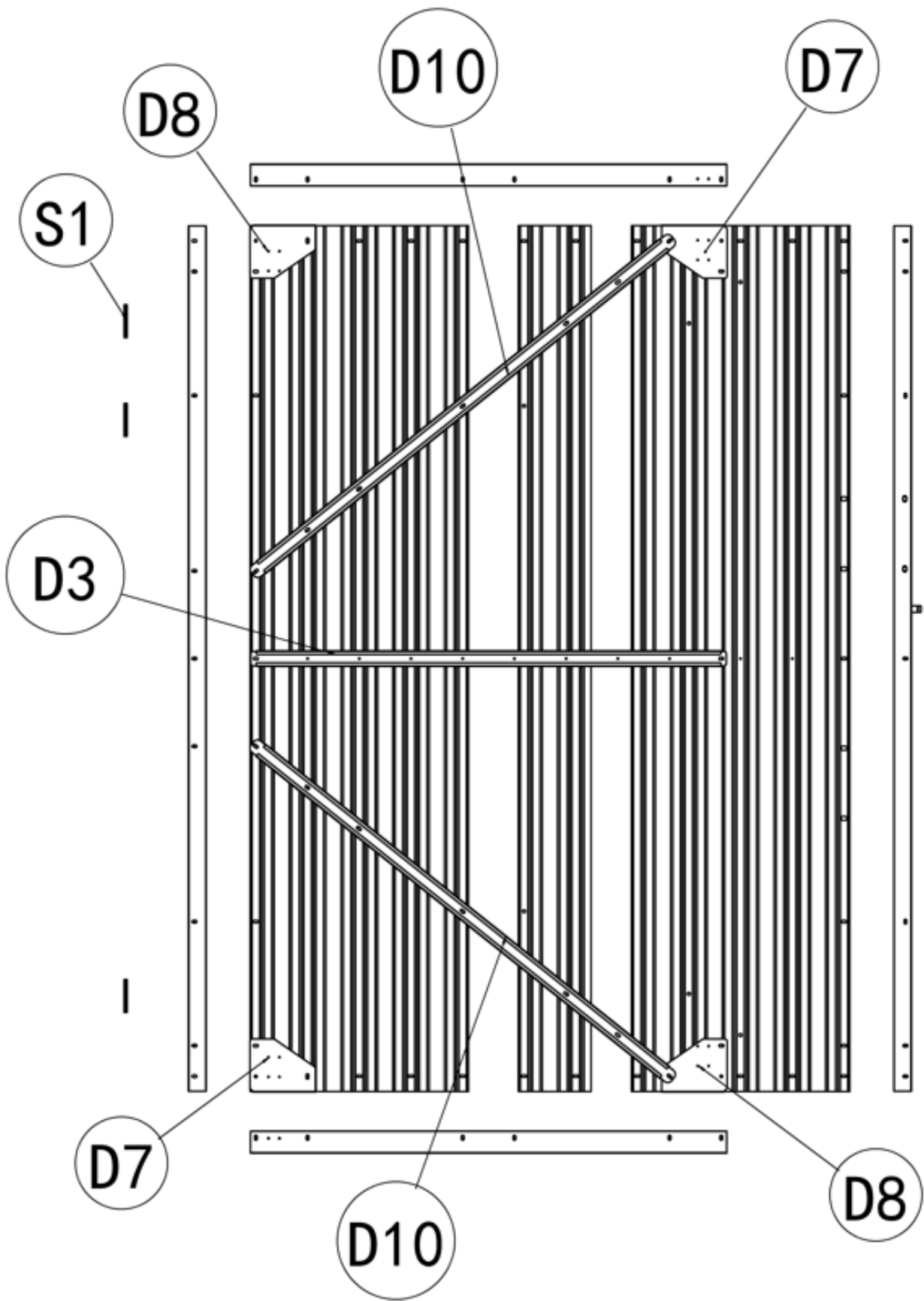

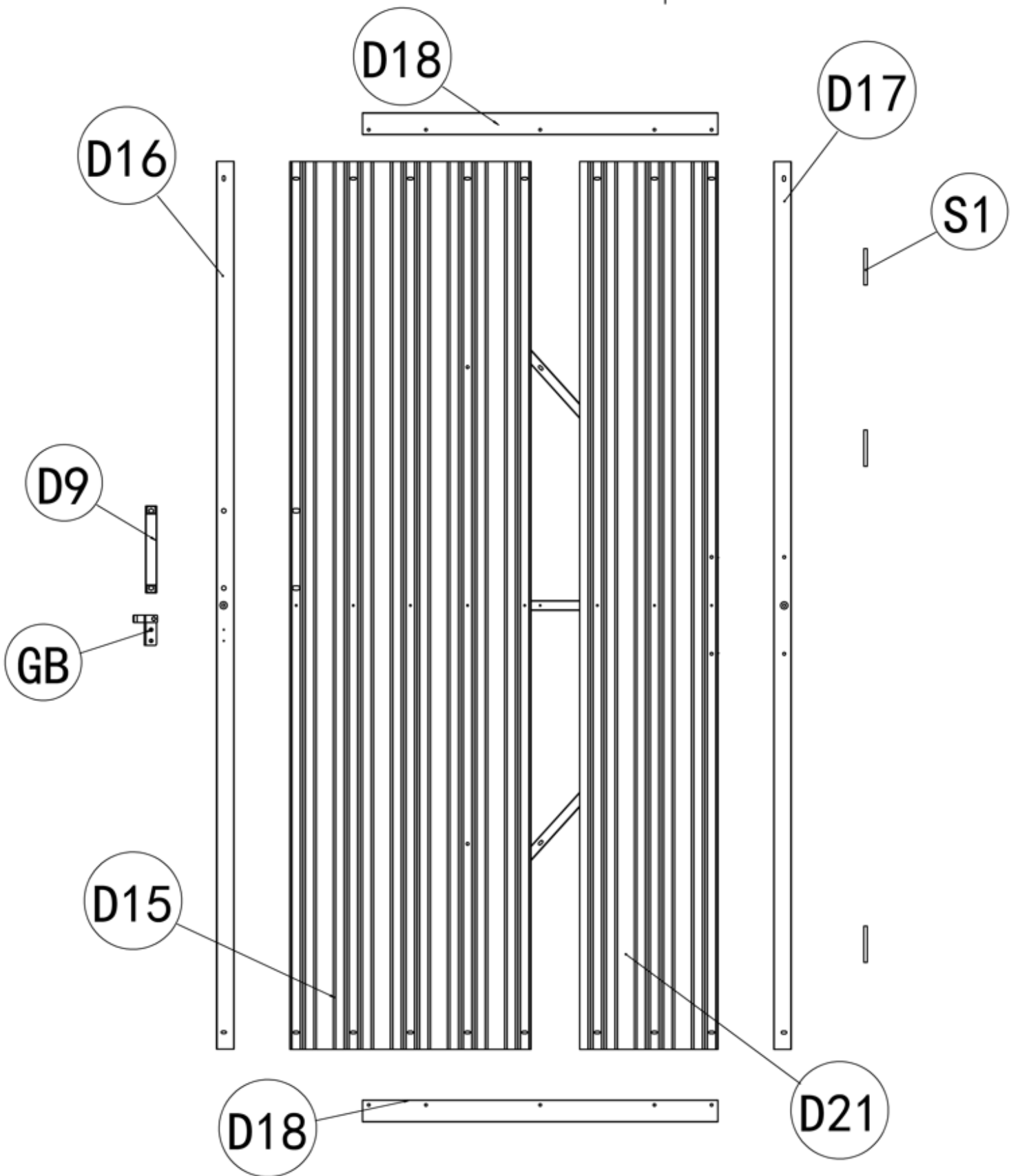

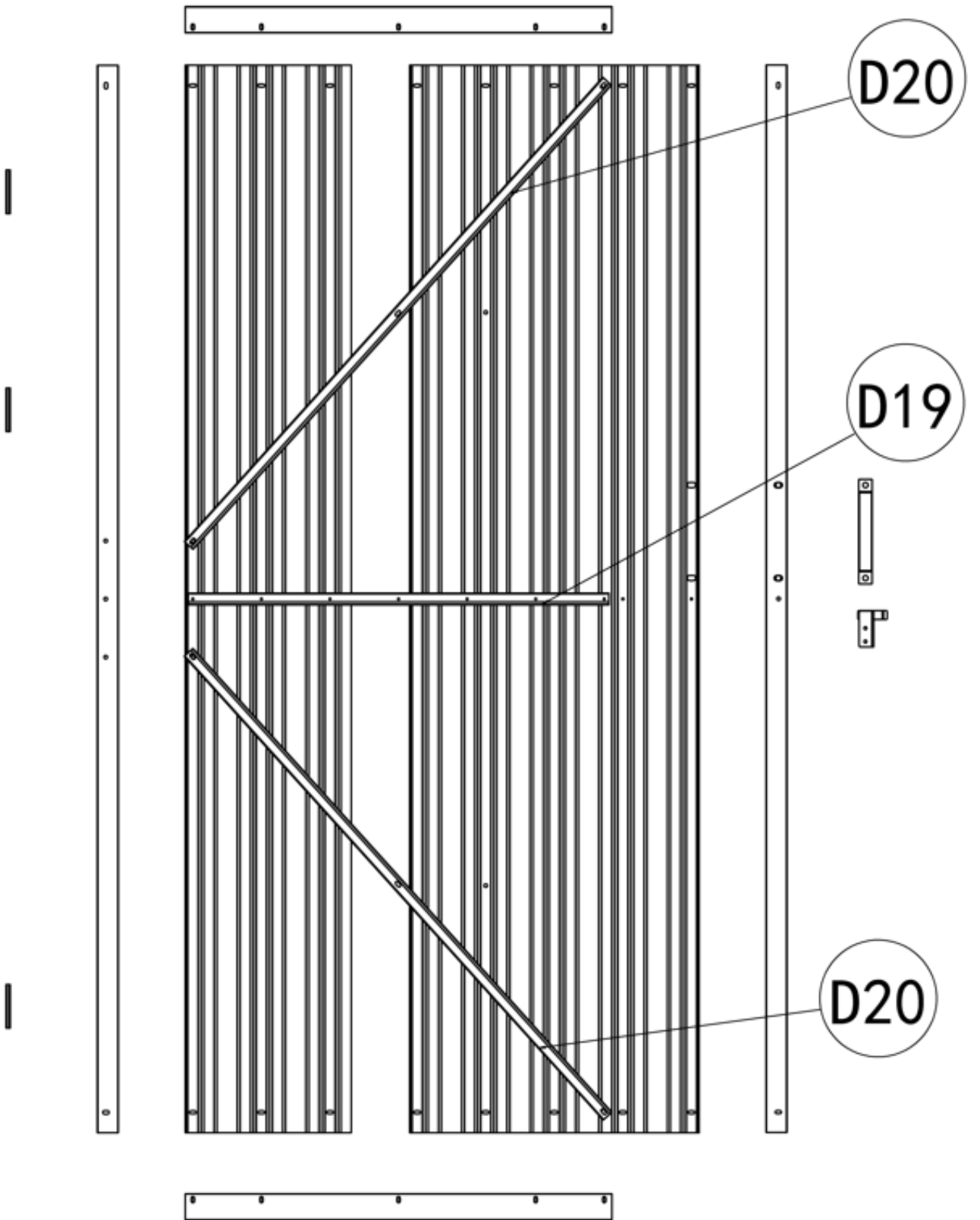









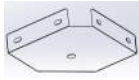
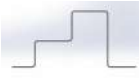

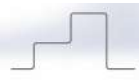
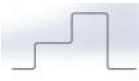

# 1.Base installation/Installation du socle

1. Connect 1R, 1M, and 1L with F1 screws, and then install E5 and fix it with F1;
2. Fix 4L and 4R with F1, and then install E5 with F1;
3. Connect 2, 3, 23, and 24 with F1;
4. Connect 14 with F1 on four corners; Then fix with GE on the ground after confirming the size.

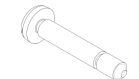
1. Connectez 1R, 1M et 1L avec des vis F1, puis installez E5 et fixez-le avec F1 ;
2. Corrigez 4L et 4R avec F1, puis installez E5 avec F1 ;
3. Connectez 2, 3, 23 avec F1;
4. Connectez 14 avec F1 sur quatre coins ; Corrigez avec GE après avoir confirmé la taille

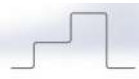
Part	No	Qty	Part	No	Qty	Part	No	Qty
	24	2		14	4		1L	2
	23	2		1R	1		4L	1
	2	1		E5	5		4R	1
	3	1		1M	2		GE	11
	F1	30		16	1			

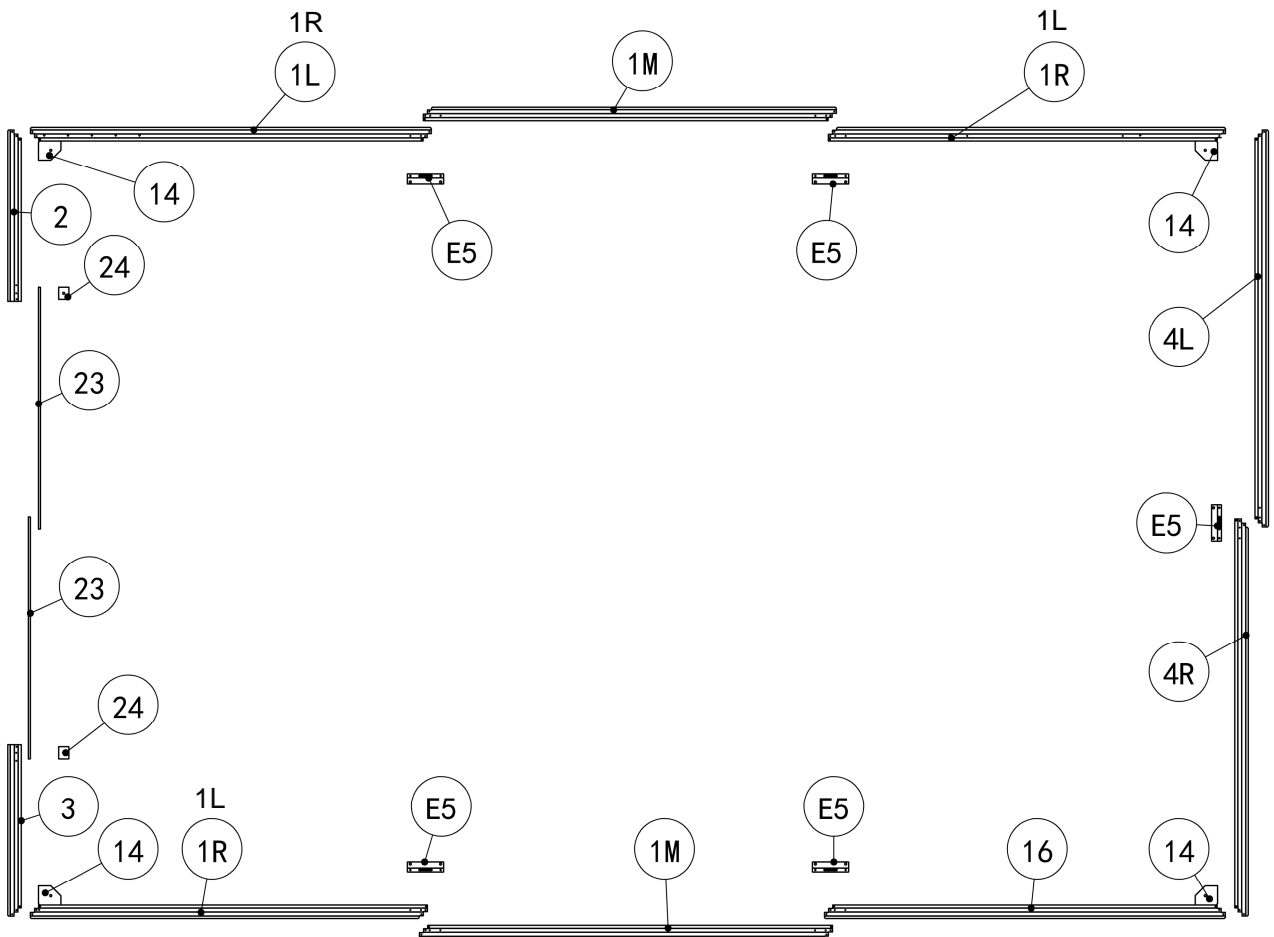

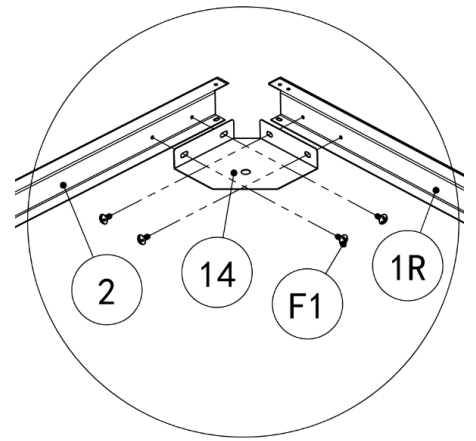
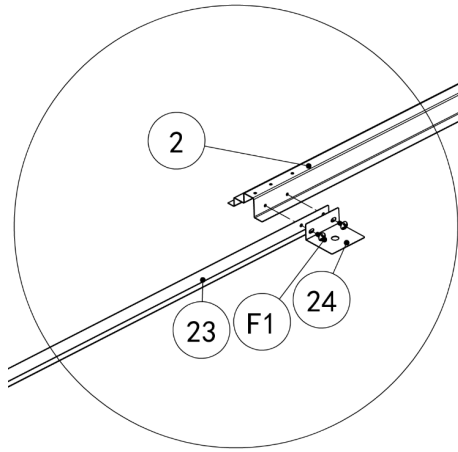
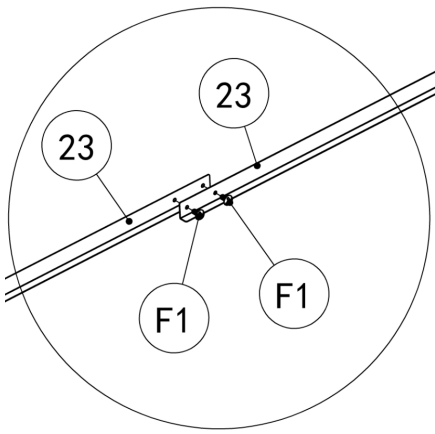





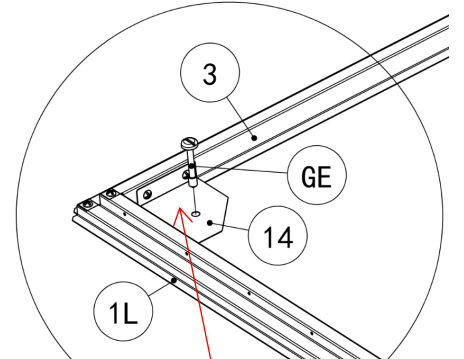
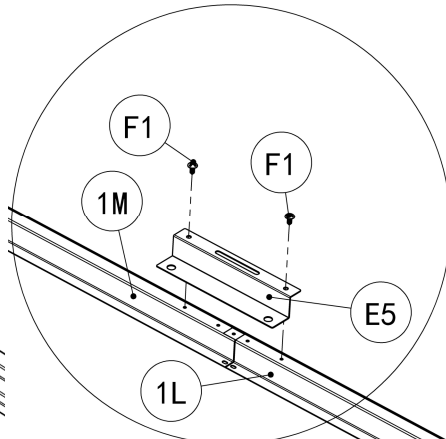
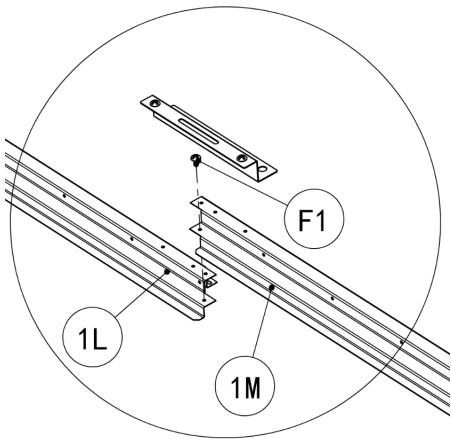
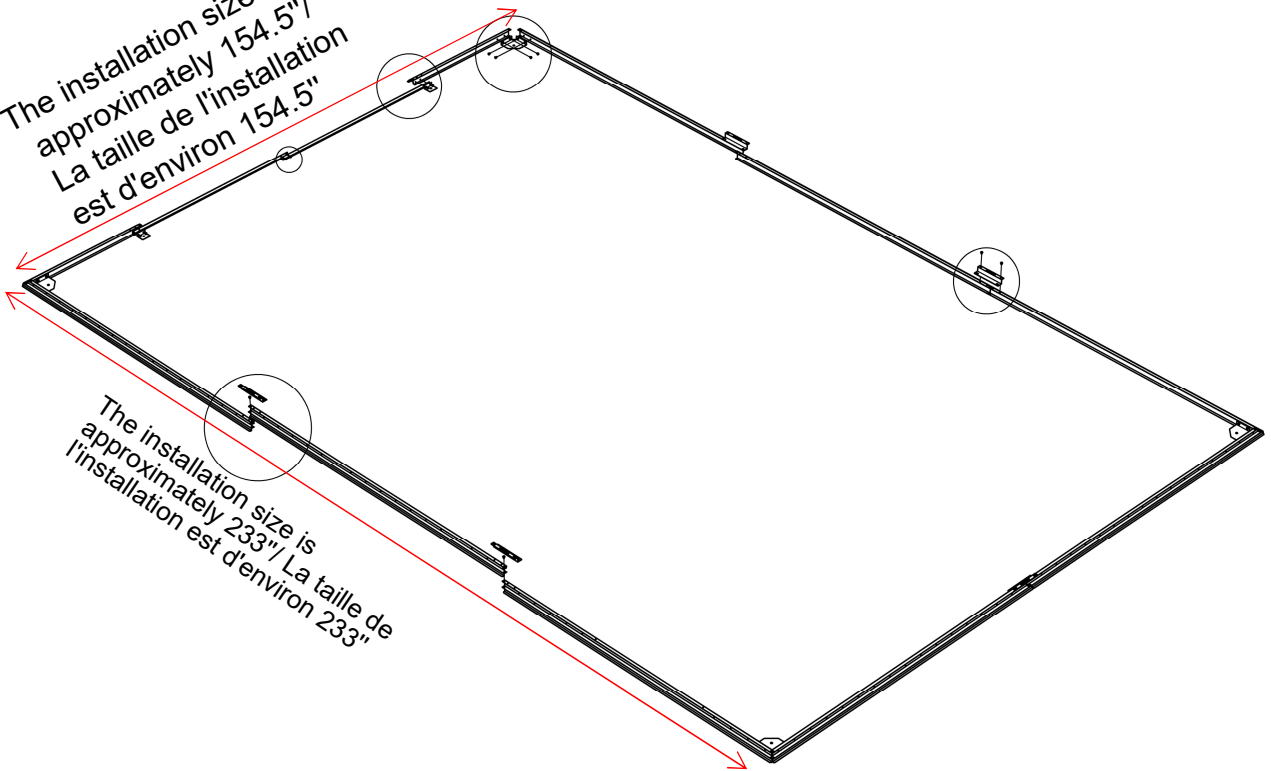





































The installation size is approximately 154.5"  
La taille de l'installation est d'environ 154.5"

The installation size is approximately 233"  
La taille de l'installation est d'environ 233"



Fix with GE the expansion screws after size confirmation/Fixer avec des vis d'expansion après confirmation de la taille

## 2. Wall Frame Assembly/Assemblage du cadre mural

Part	No	Qty	Part	No	Qty	Part	No	Qty
	P1	4		22R	1		ABR	2
	P2	2		7	1		ABM	2
	12R	1		8	1		E6	4
	12L	1		A1	1		E2	4
	9R	1		10M	2		E3	4
	9L	1		11M	2		E4	4
	10L	1		17	1		E1	2
	10R	2		18	1		P3	2
	11L	1		19	1		F1	172
	11R	2		20	2		F7	78
	P3	2		21	4		F2	52
	22L	1		ABL	2		F6	64
	E9	26		E10	2		F16	12
	E11	4		E7	4			
	E12	4		E8	4			

1. Install P1 on the base using F1 and F7;/ Installez P1 sur la base en utilisant F1 et F7 ;

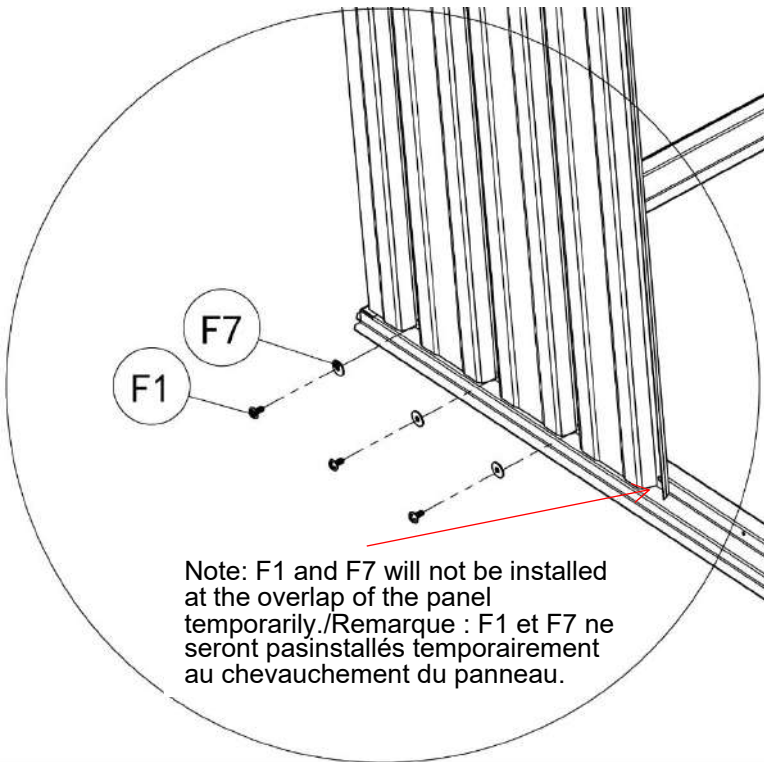
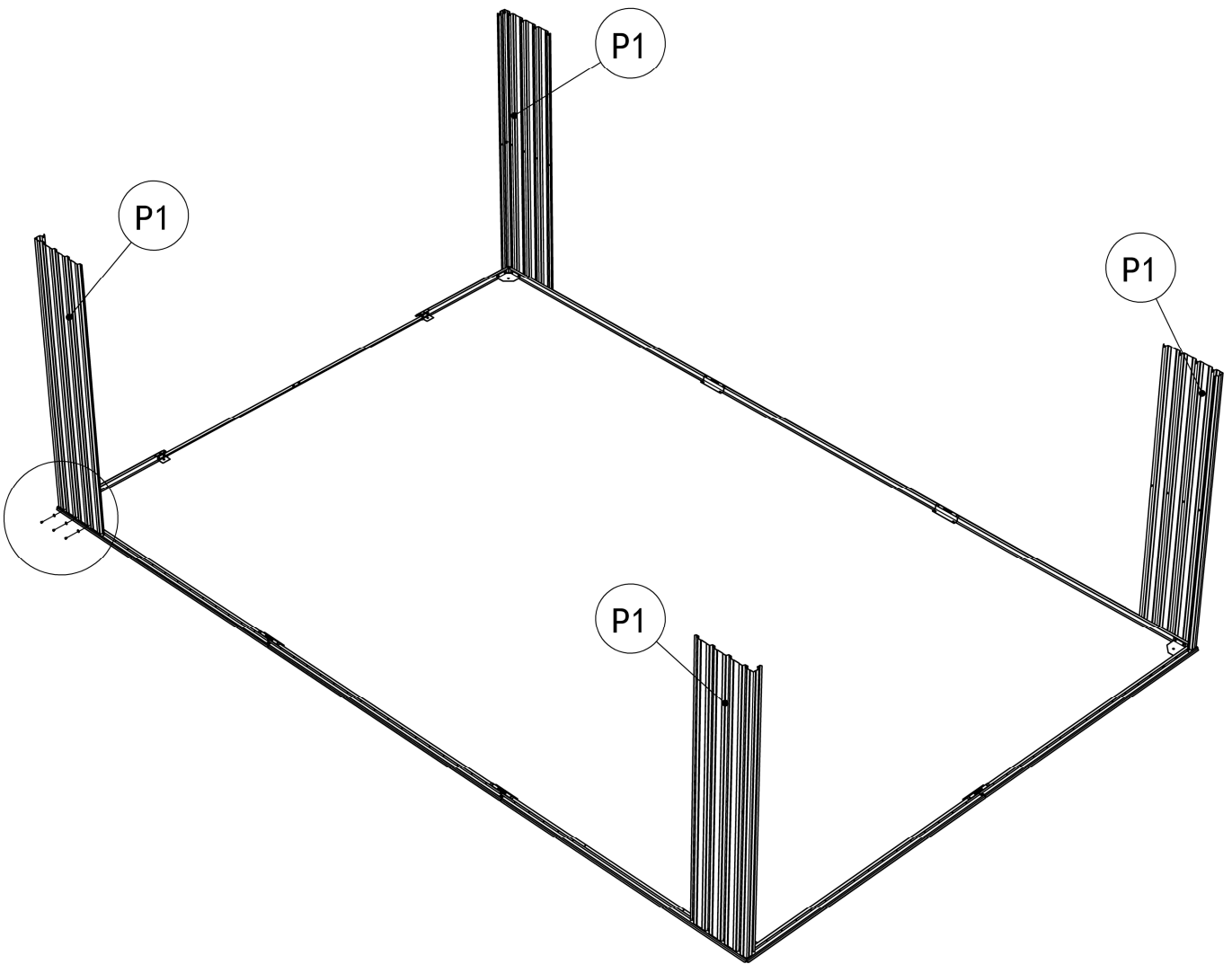

2. Fix P2 with F1 and F7; connect 9L, 9R, 12L, 12R with F1/Corrigez P2 avec F1 et F7, 9L, 9R, 12L, 12R et F1 ;

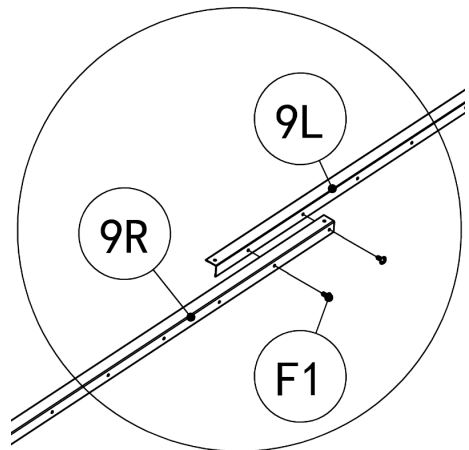
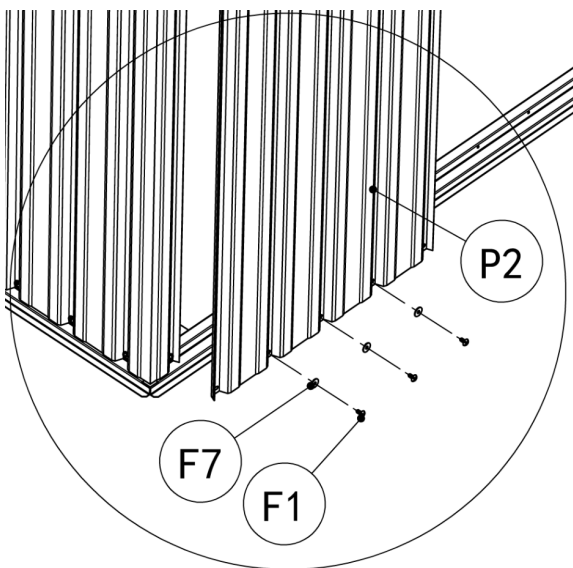
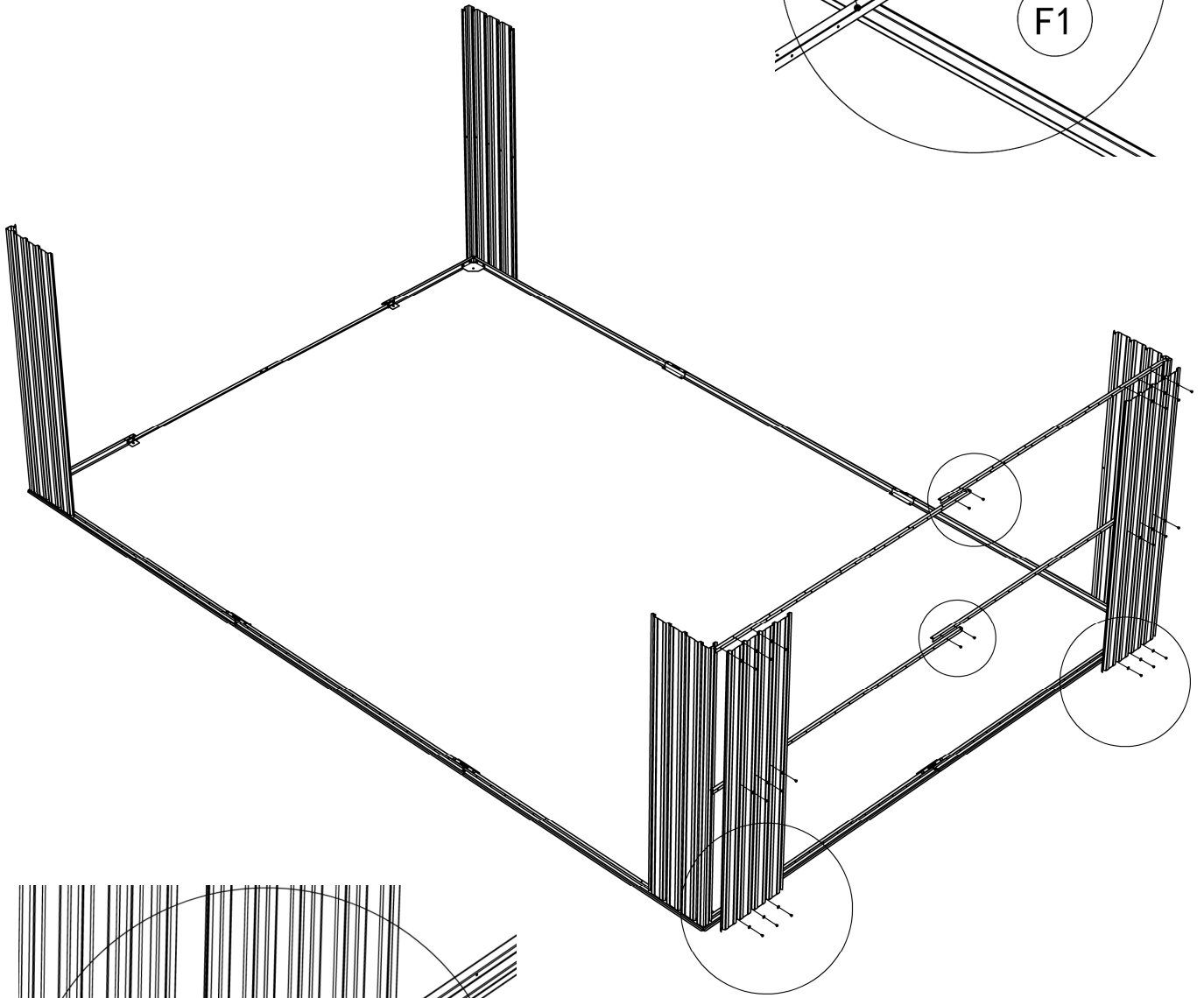
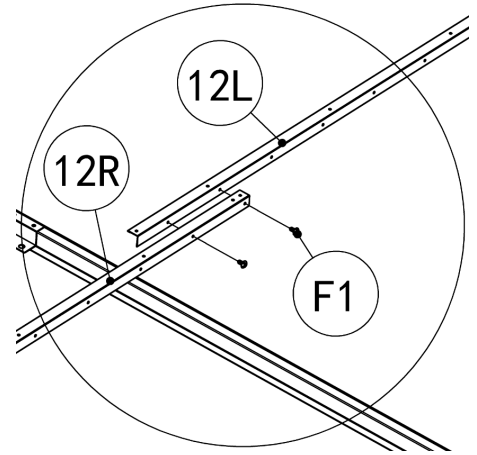

3. Fix 20,21 and E9 with F1; Fix 22L, P3, 11R, P2, and 10L with F1 and F7.

The installation method on the other side is the same. Fix 20,21, and E9 with F1, then fix 22R, P3, 11L, P2, and 10R with F1 and F7;

3. Corrigez 20, 21, E9 avec F1; Corrigez 22R, P3, 11R, P2 avec F1 et F7.

La méthode d'installation de l'autre côté est la même. Corrigez 20,21 et E9 avec F1, puis corrigez 22R, P3, 11L, P2 et 10R avec F1 et F7.

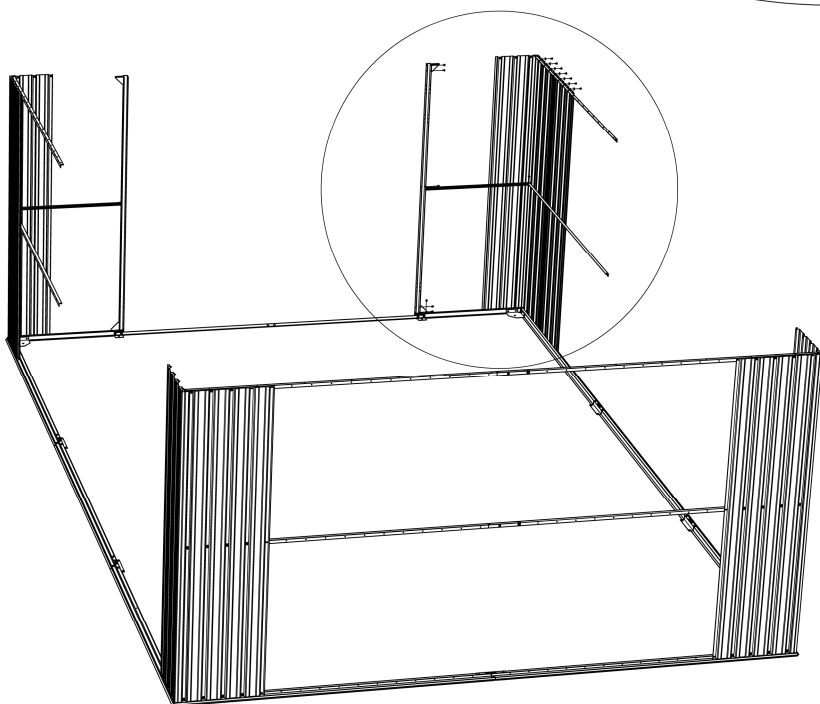
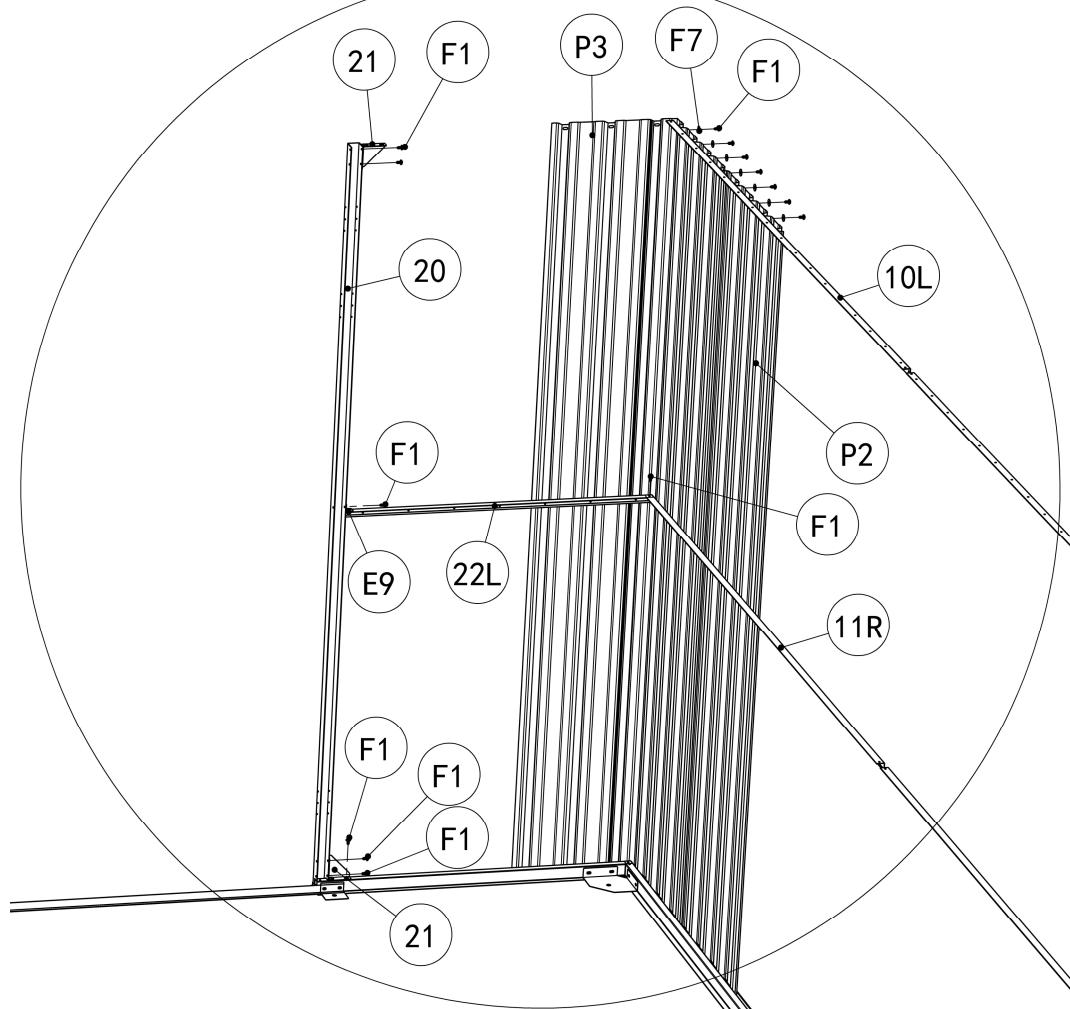

4. First, fix E8 & E9 with F1; Connect 11R, 11M & 11L; 10L, 10M & 10R with F1./ Tout d'abord, fixez E8 et E9 avec F1; Connectez 11R, 11M & 11L; 10L, 10M & 10R avec F1.

Install the other side in the same way, fix E8 & E9 with F1, connect 11L, 11M, 19 with F1; 10L, 10M, 17 with F1; / Installez l'autre côté de la même manière, fixez E8 et E9 avec F1, Connectez 11L, 11M, 19 avec F1; 10L, 10M, 17 avec F1

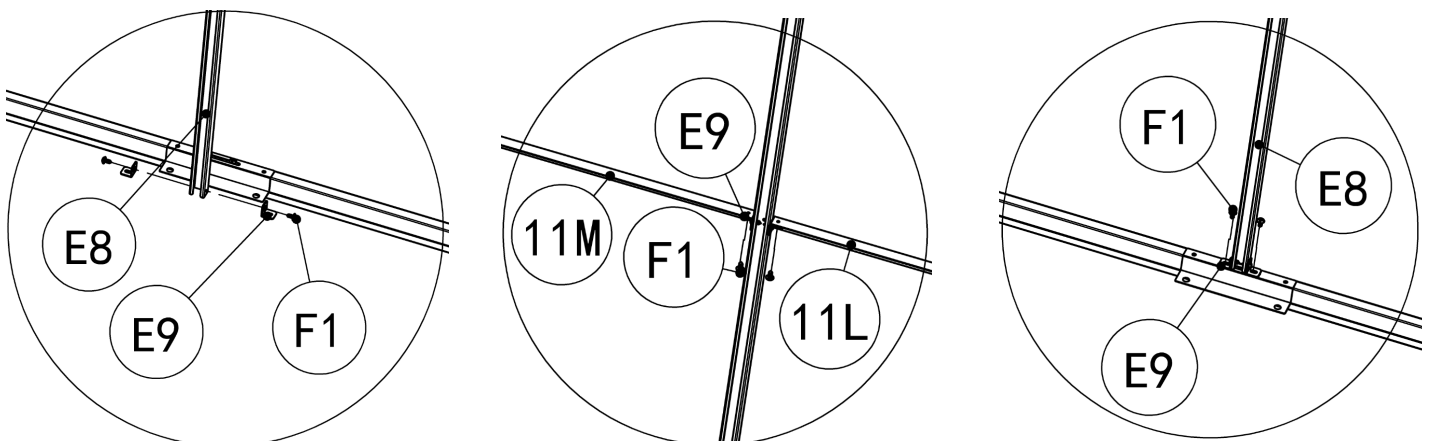
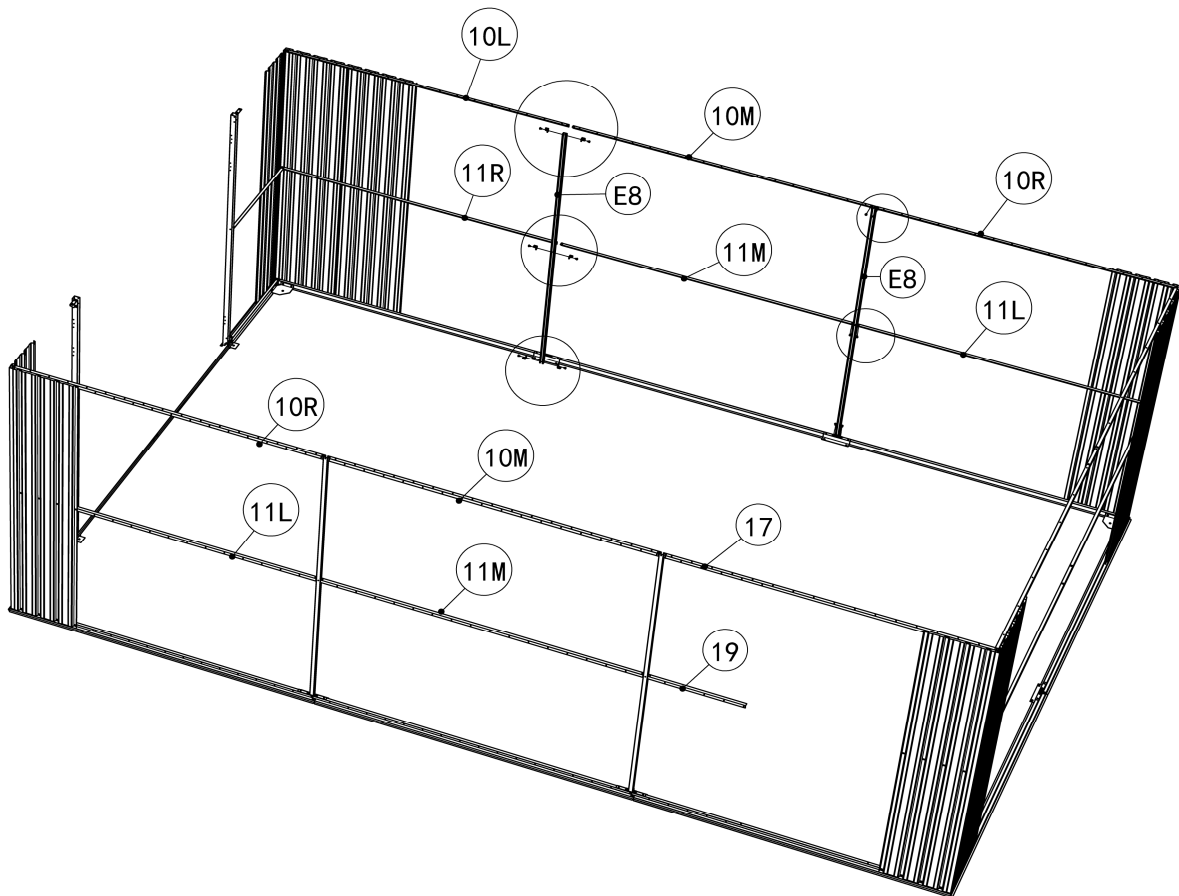
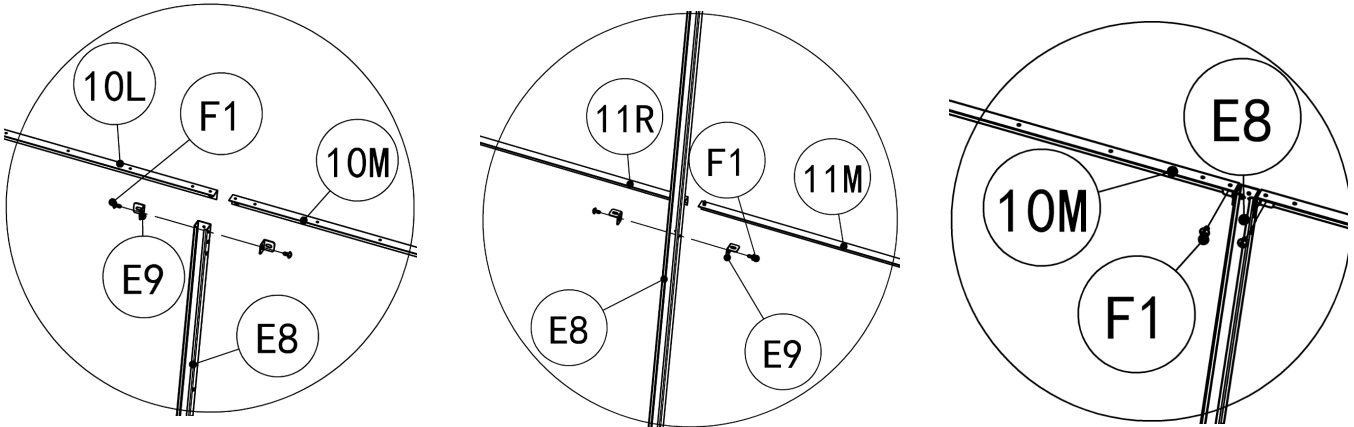

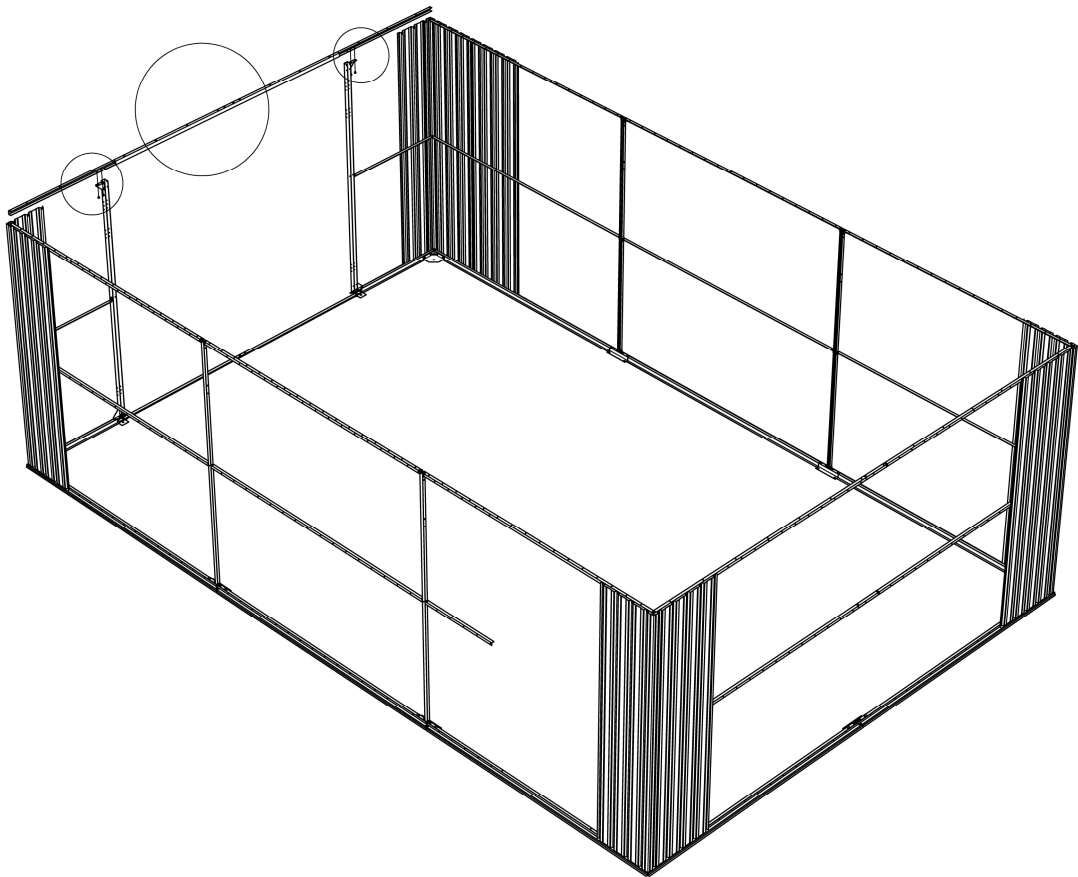
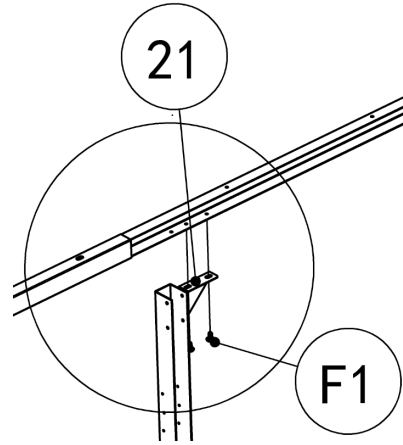
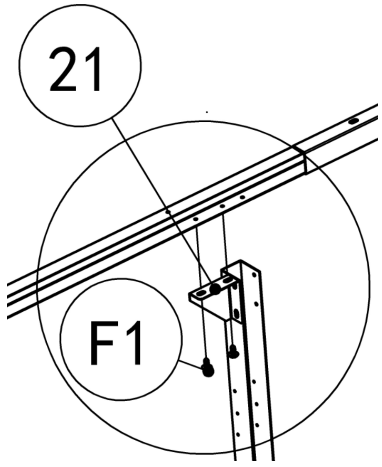

5. Connect 7 and 8 into a straight line with the A1 more holes facing upwards, and the side with less holes fixed with F1; fix with 21 & F1 after assembly./Connectez 7 et 8 en ligne droite avec le A1 plus de trous tournés vers le haut et le côté avec moins de trous fixé avec F1 ; réparer avec 21 & F1 après assemblage

The side with more holes facing upwards./Le côté avec le plus de trous tourné vers le haut

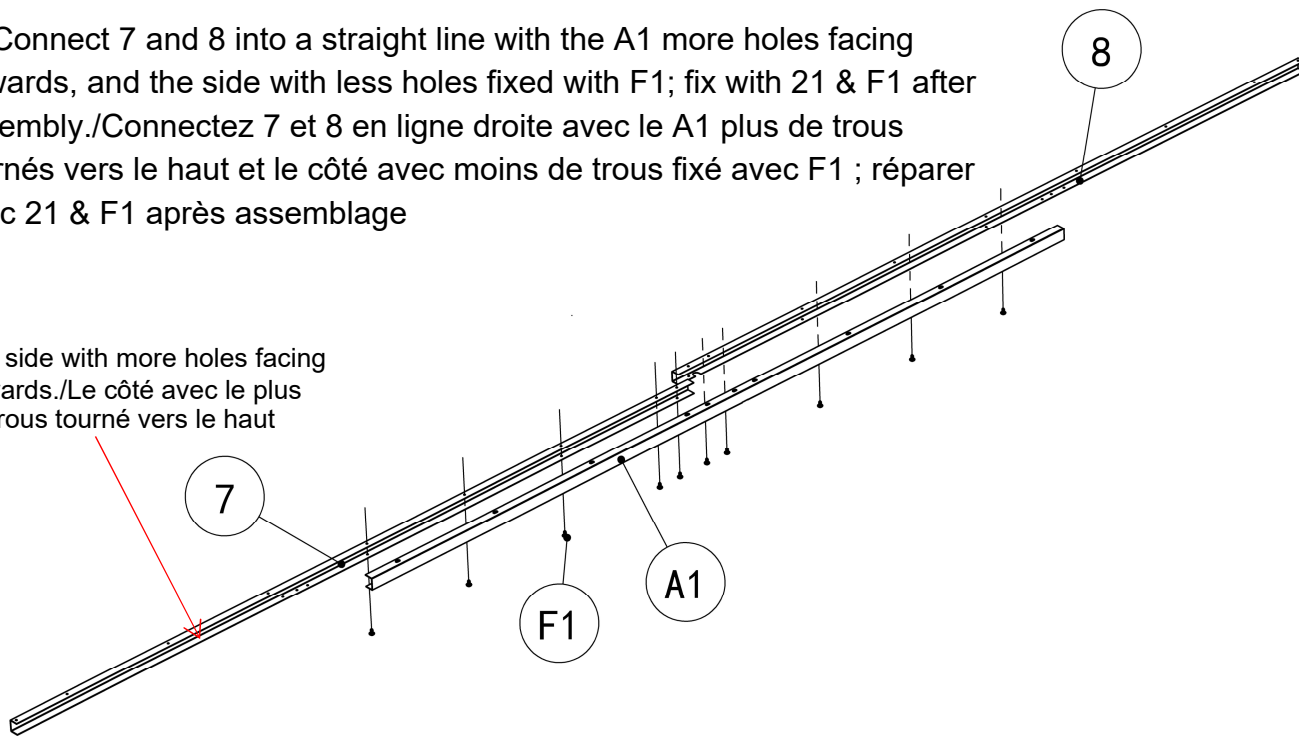

6. First fix two E3 with F2 & F6, then install E4 with F2 & F6, connect E2 with F2 & F6; Fix two E6 with F2 & F6, then install E11 with F2 & F6, connect E2 with F2 & F6; Connect E3 and E6 with E10 and fix them with F2 & F6; Then connect E3 and E6 with E1 and fix them with F2 & F6; Connect this component with E7 , E10 and secure them with F2, F16& F6.

6. Fixez d'abord deux E3 avec F2 et F6, puis installez E4 avec F2 et F6, connectez E2 avec F2 et F6; Fixez deux E6 avec F2 et F6, puis installez E11 avec F2 et F6, connectez E2 avec F2 et F6 ; Connectez E3 et E6 avec E10 et corrigez-les avec F2 & F6 ; Connectez ensuite E3 et E6 avec E1 et corrigez-les avec F2 & F6 ; Connectez ce composant avec E7, E10 et sécurisez-les avec F2, F16 et F6.

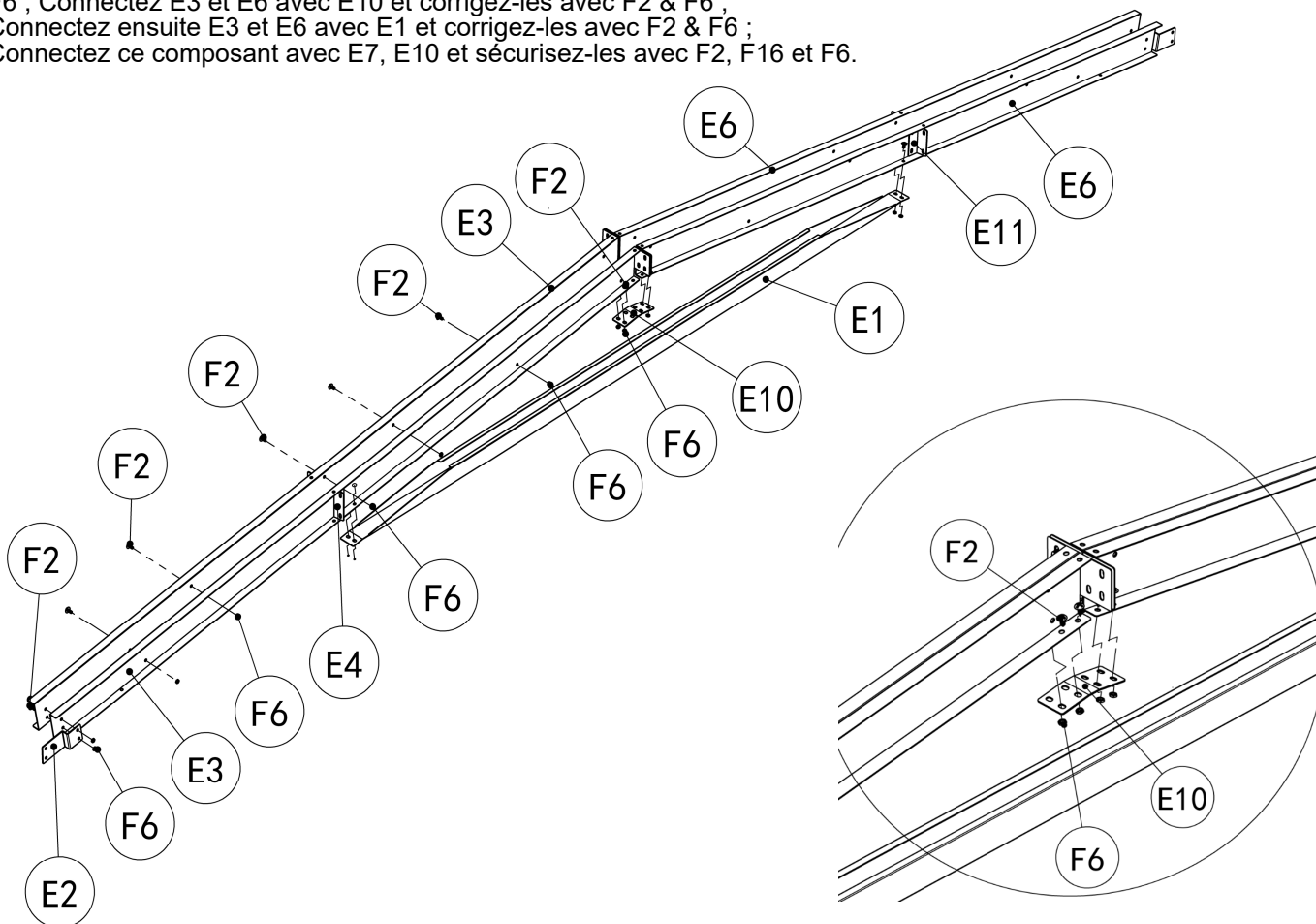

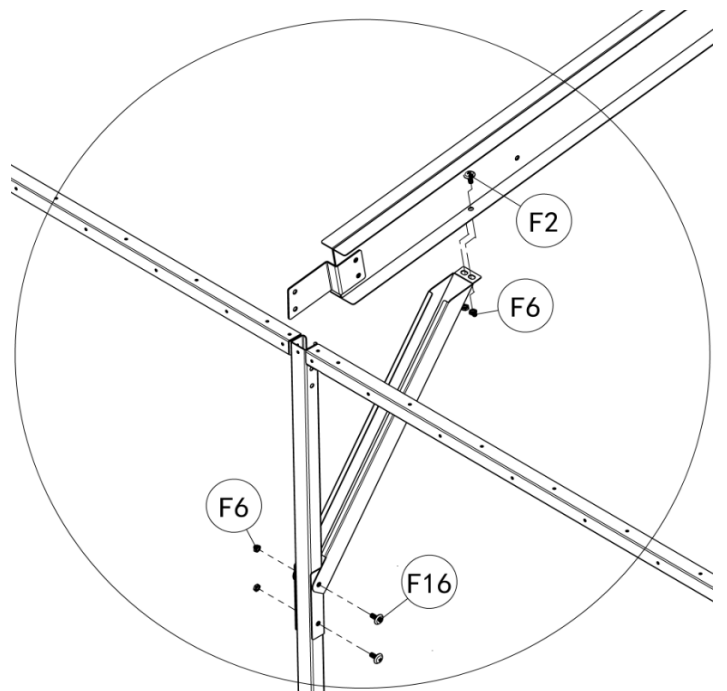
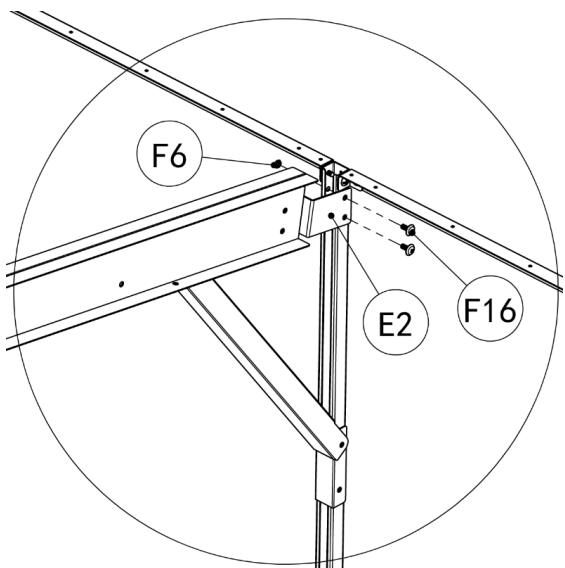
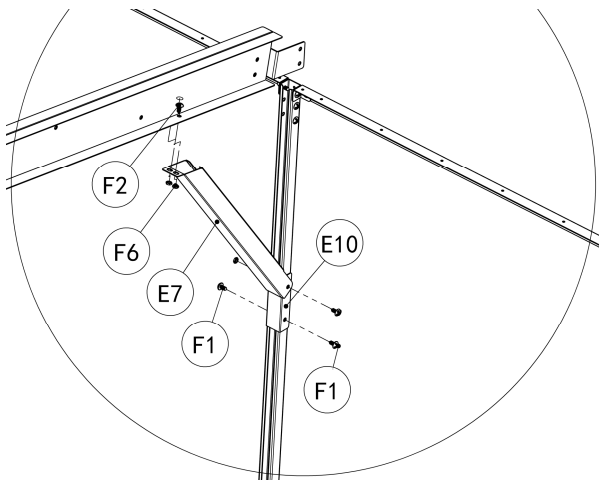
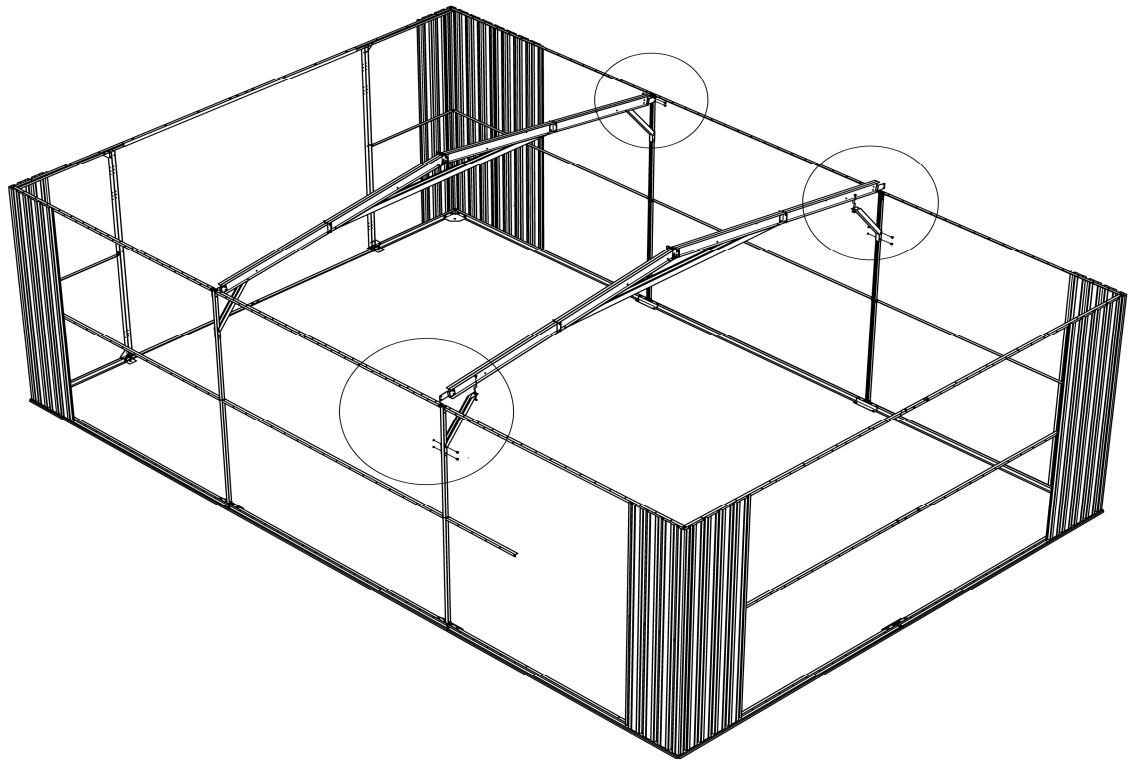

### 3. Roof Frame Assembly/Assemblage de la charpente du toit

Part	No	Qty	Part	No	Qty	Part	No	Qty
	APL	2		ABL	2		CL	2
	APR	2		ABR	2		CR	2
	PL	4		ABM	2		CM	2
	C2	2		F2	73		F1	32
	C3	2		F6	73		E4	4
	E11	4						

1. PL clamp APR and APL, connect and fix them with F2 and F6, install the components on 7,8, A1, and fix them with F1./PL serrez APR et APL, connectez-les et fixez-les avec F2 et F6, installez les composants sur 7,8, A1 et fixez-les avec F1 ;

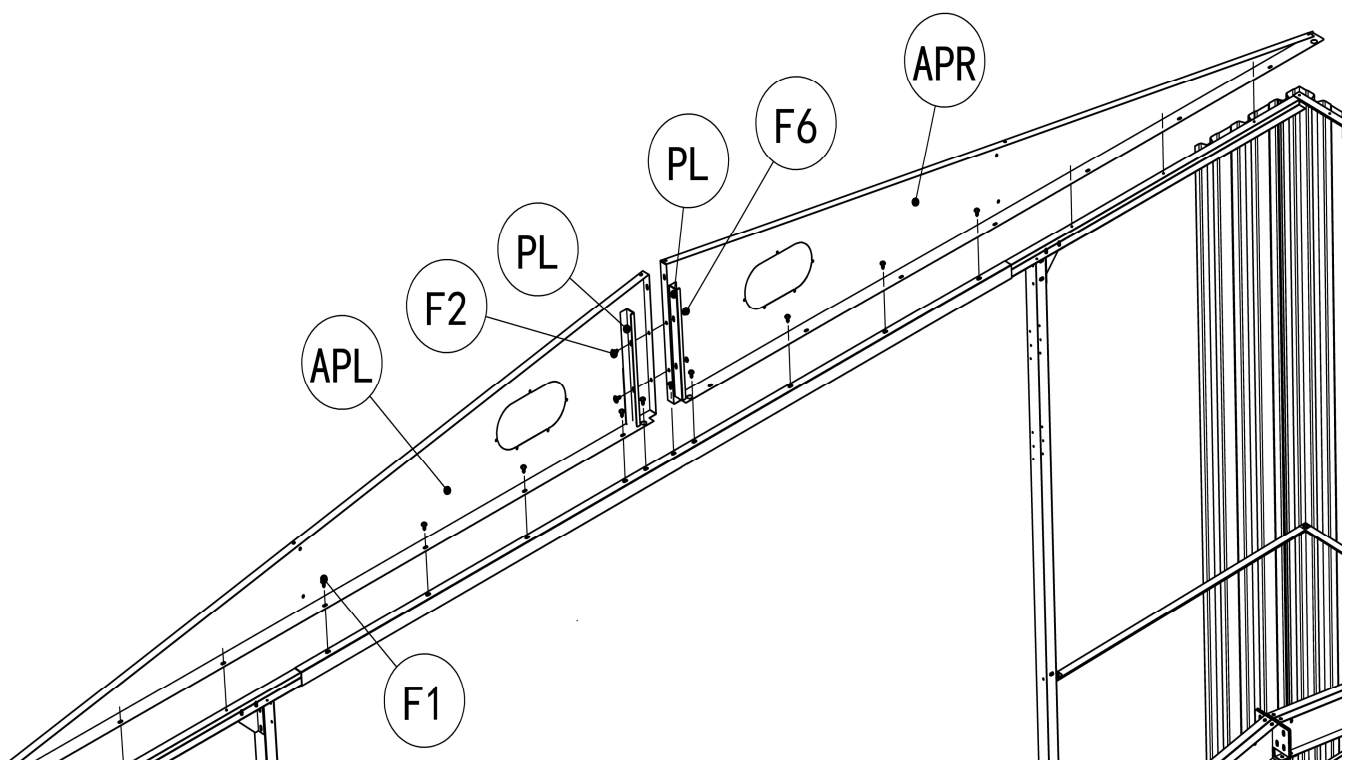

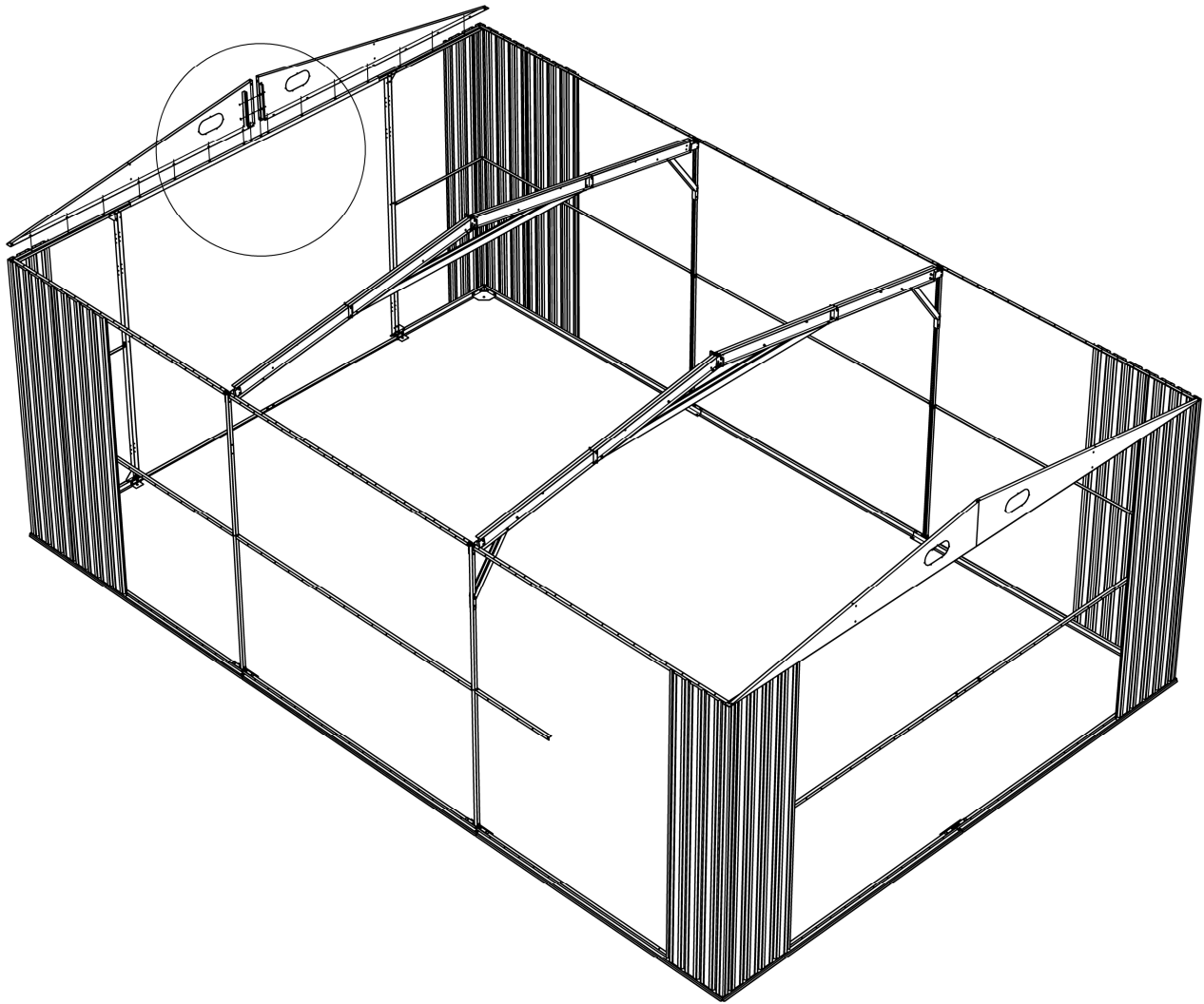

3. Fix ABR and ABL with F2 and F6, then insert them diagonally into APR and APL, frame them on PL, fix them with F2 and F6, and then connect the other end into slots E3 and E6, and fix them with F2 and F6.

Fix C2 and C3 with F1, then connect CL, CR with F2 and F6, CR with E4 with F2 and F6,

2. Fix the two ABMs with F2 and F6, place them in the E3 and E6 card slots from top to bottom, and fix them with F2 and F6. Fix CM, E4, and E11 with F2 and F6;

4. Fix ABR and ABL with F2 and F6, then insert them diagonally into APR and APL, frame them on PL, fix them with F2 and F6, and then connect the other end into slots E3 and E6, and fix them with F2 and F6. Fix C2 and C3 with F1, then connect CL, CR with F2 and F6, CR with E4 with F2 and F6, CL with E11 with F2 and F6.

3. Fixez ABR et ABL avec F2 et F6, puis insérez-les en diagonale dans APR et APL, montez-les sur PL, fixez-les avec F2 et F6, puis connectez l'autre extrémité dans les emplacements E3 et E6 et fixez-les avec F2 et F6.

Fixez C2 et C3 avec F1, puis connectez CL, CR avec F2 et F6, CR avec E4 avec F2 et F6,

2. Fixez les deux ABM avec F2 et F6, placez-les dans les emplacements pour cartes E3 et E6 de haut en bas et fixez-les avec F2 et F6. Corrigez CM avec E4 et E11 en utilisant F2 et F6 ;

4. Fixez ABR et ABL avec F2 et F6, puis insérez-les en diagonale dans APR et APL encadrez-les sur PL, fixez-les avec F2 et F6, puis connectez l'autre extrémité dans les emplacements E3 et E6 et fixez-les avec F2 et F6. Fixez C2 et C3 avec F1, puis connectez CL, CR avec F2 et F6, CR avec E4 avec F2 et F6, CL avec E11 avec F2 et F6.

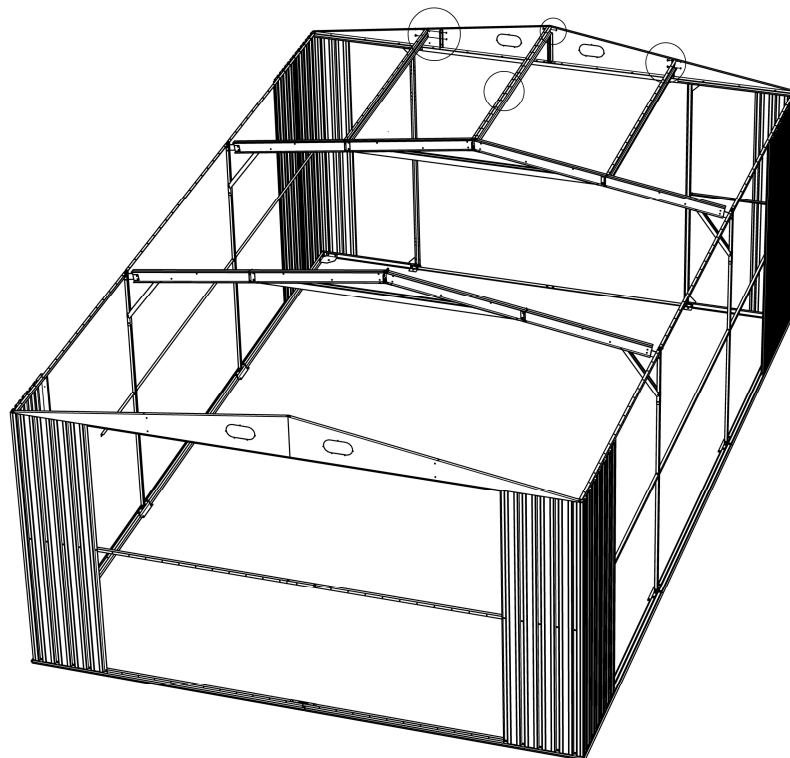
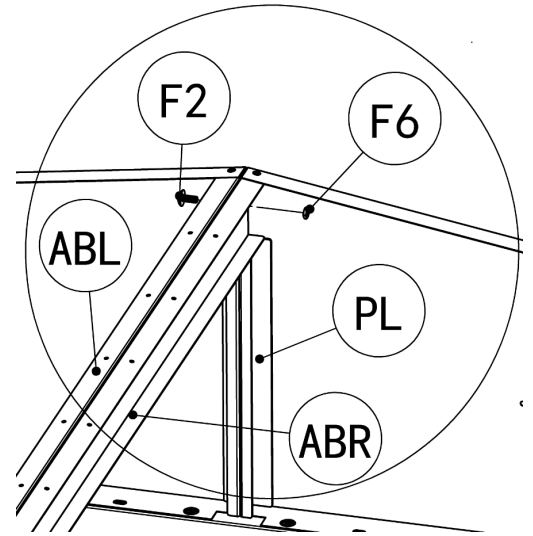
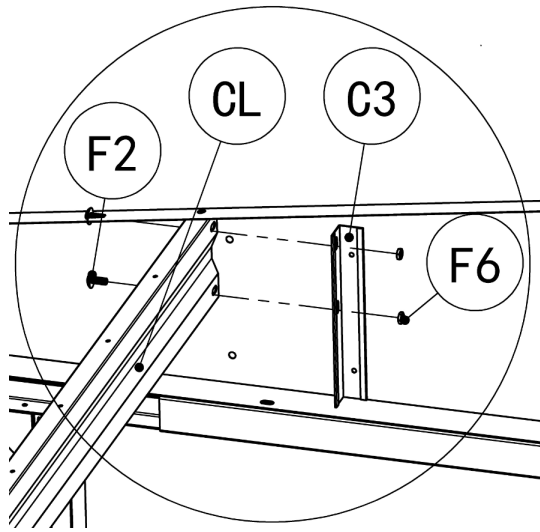
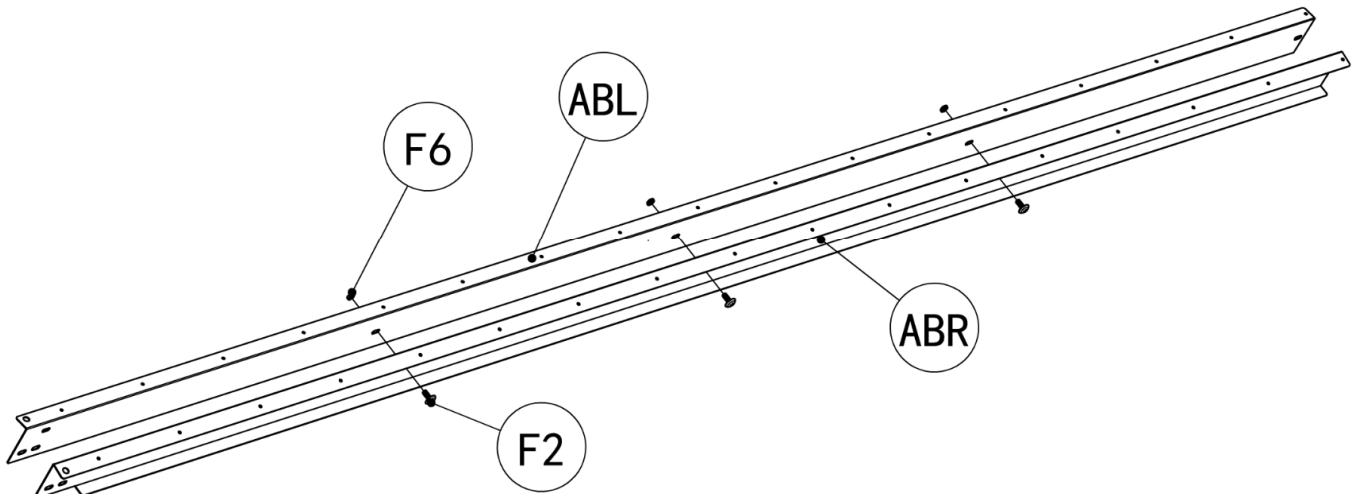

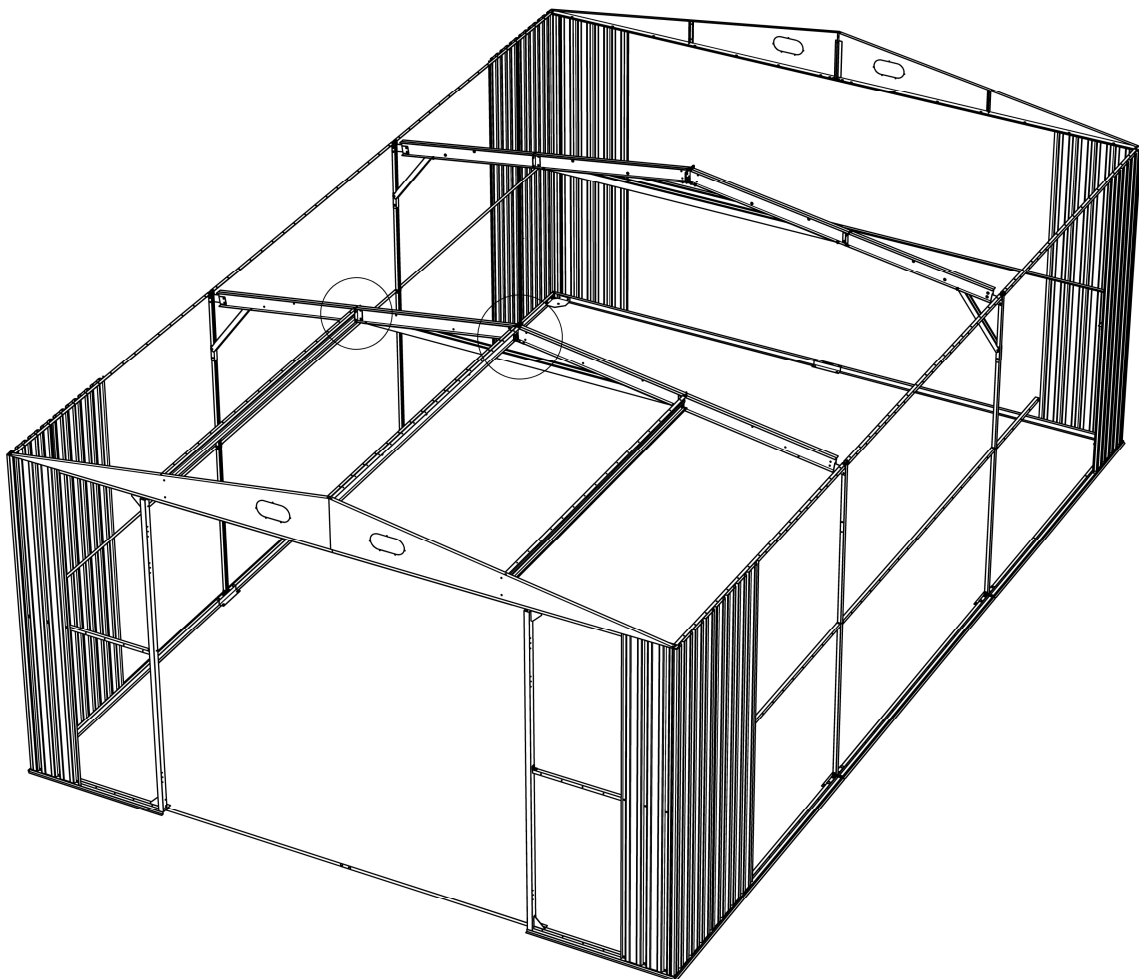
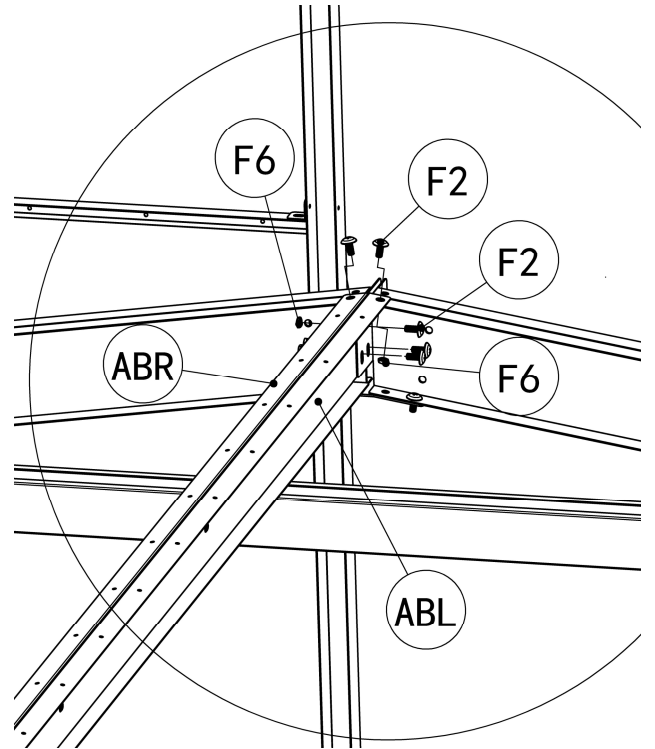
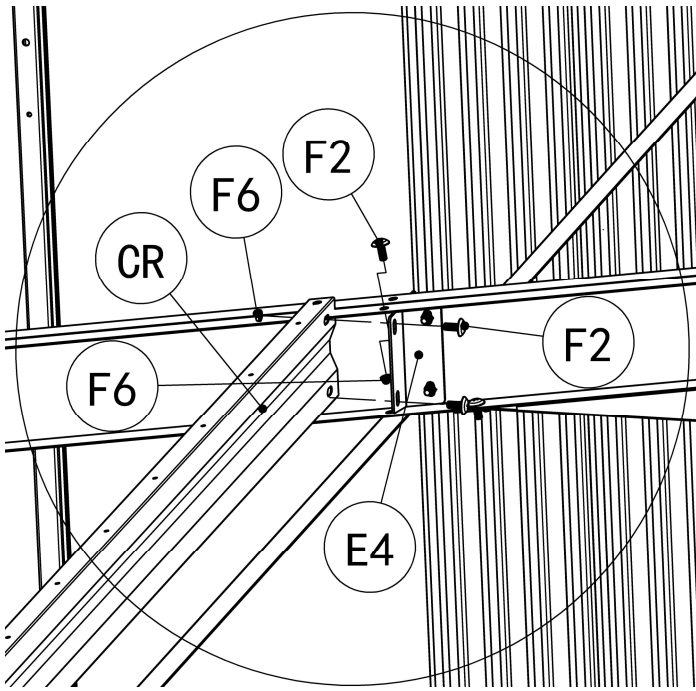

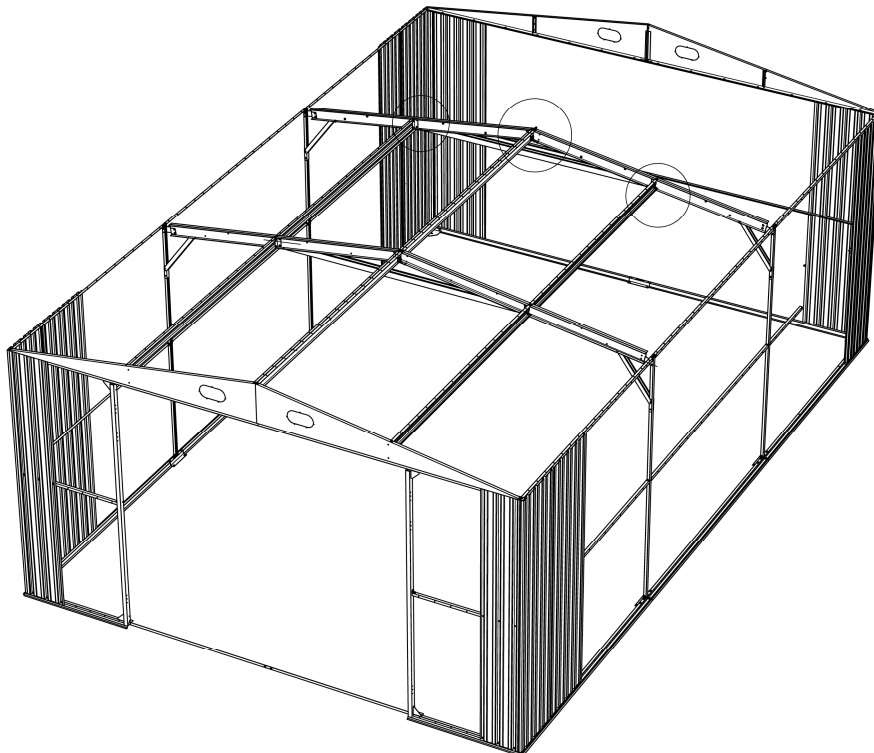
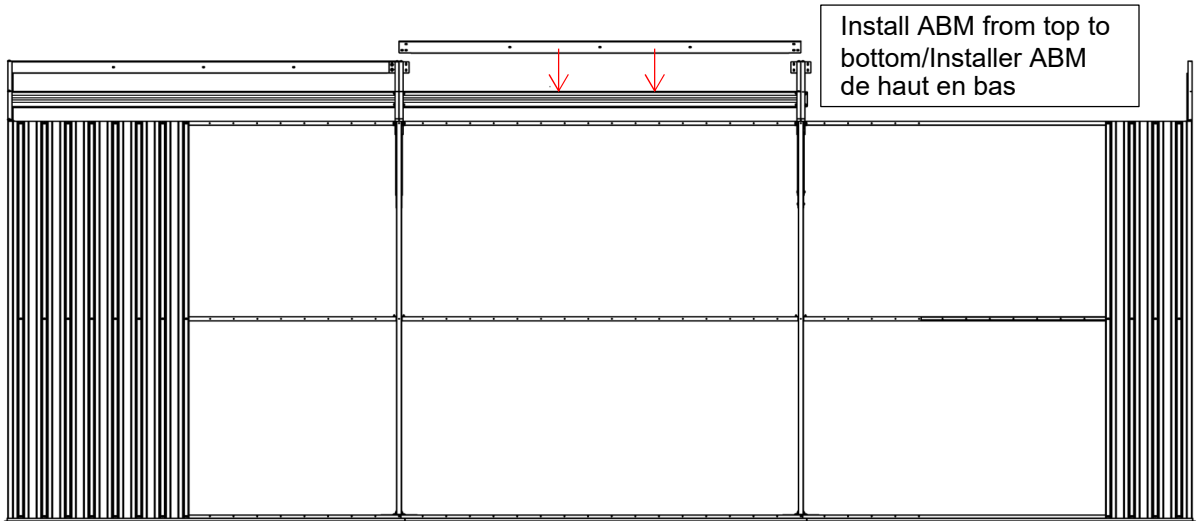
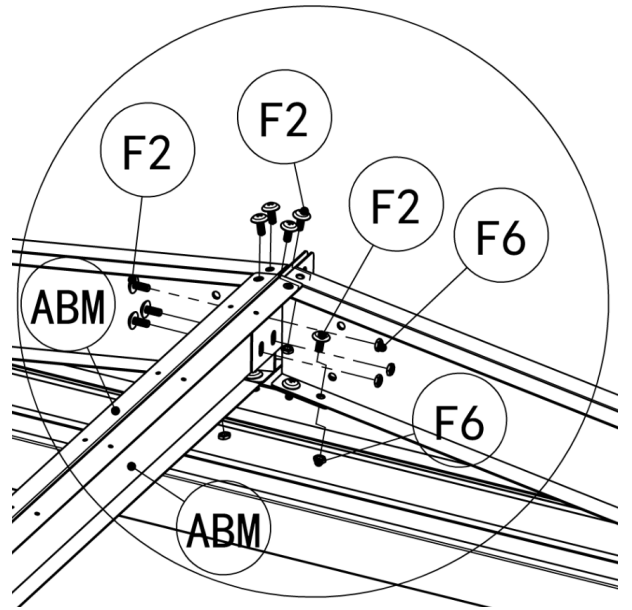
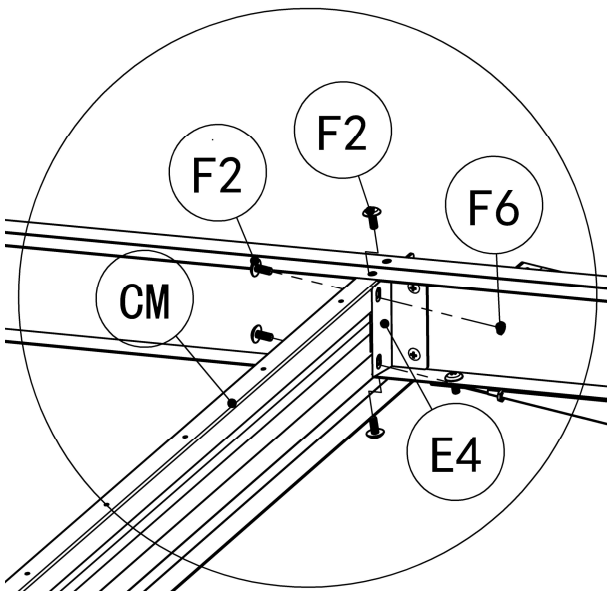

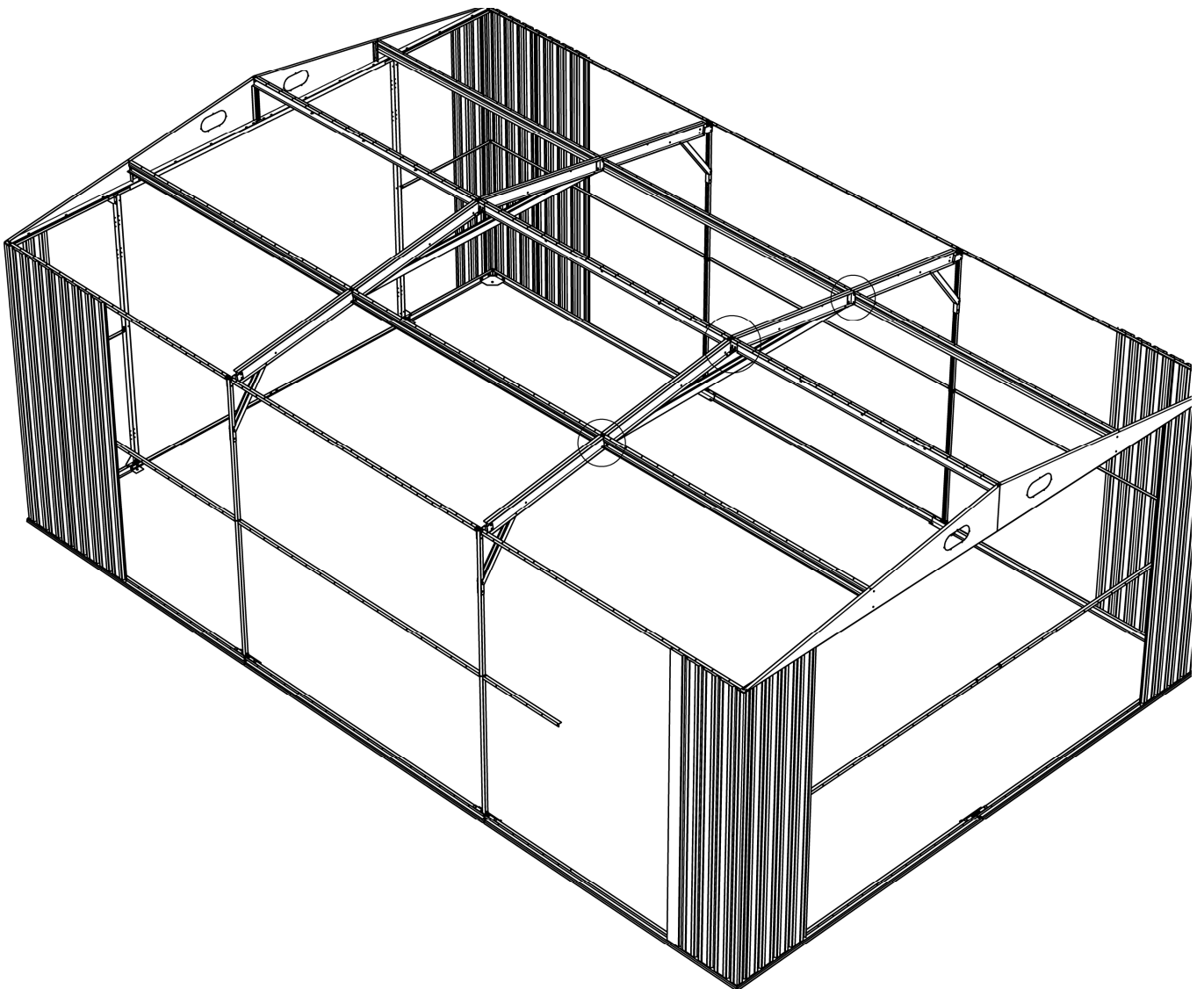
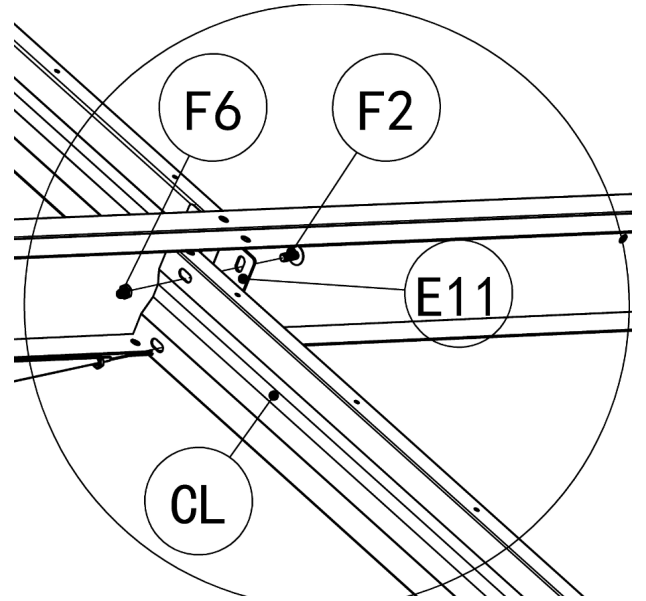
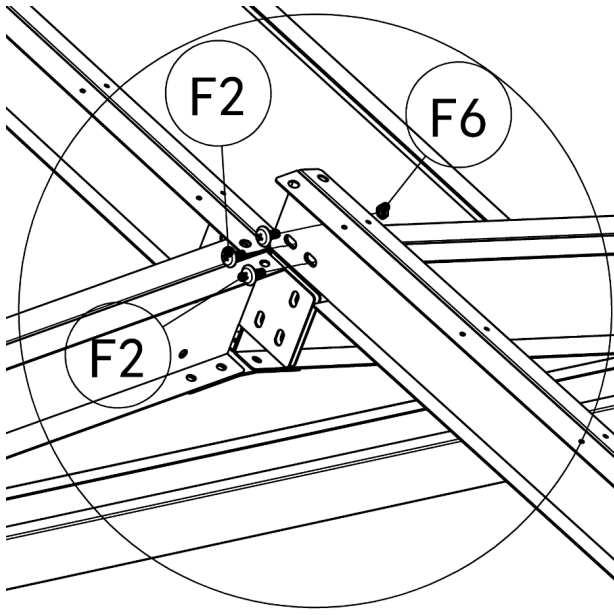







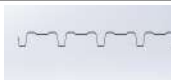

## 4.Wall Panel Assembly/Assemblage des panneaux muraux

1. Fix P2 and P4 with F1 and F7;
2. Install 15L onto P4 and secure with F1 and F7, and install 15R onto P1 and secure with F1 and F7; Then buckle 15M onto 17 and fix it with F1;
3. Install 13L and 13R onto 20 and fix them with F1 and F7;

1. Corrigez P2 et P4 avec F1 et F7
2. Installez 15L sur P4 et fixez-le avec F1 et F7, et installez 15R sur P1 et fixez-le avec F1 F7 ; Attachez ensuite 15M sur A3 et fixez-le avec F1
3. Installez 13L et 13R sur 20 et fixez-les avec F1 et F7

Part	No	Qty	Part	No	Qty	Part	No	Qty
	P2	28		F1	400		F7	396
	15L	1		13L	1			
	15R	1		13R	1			
	P4	2		15M	1			

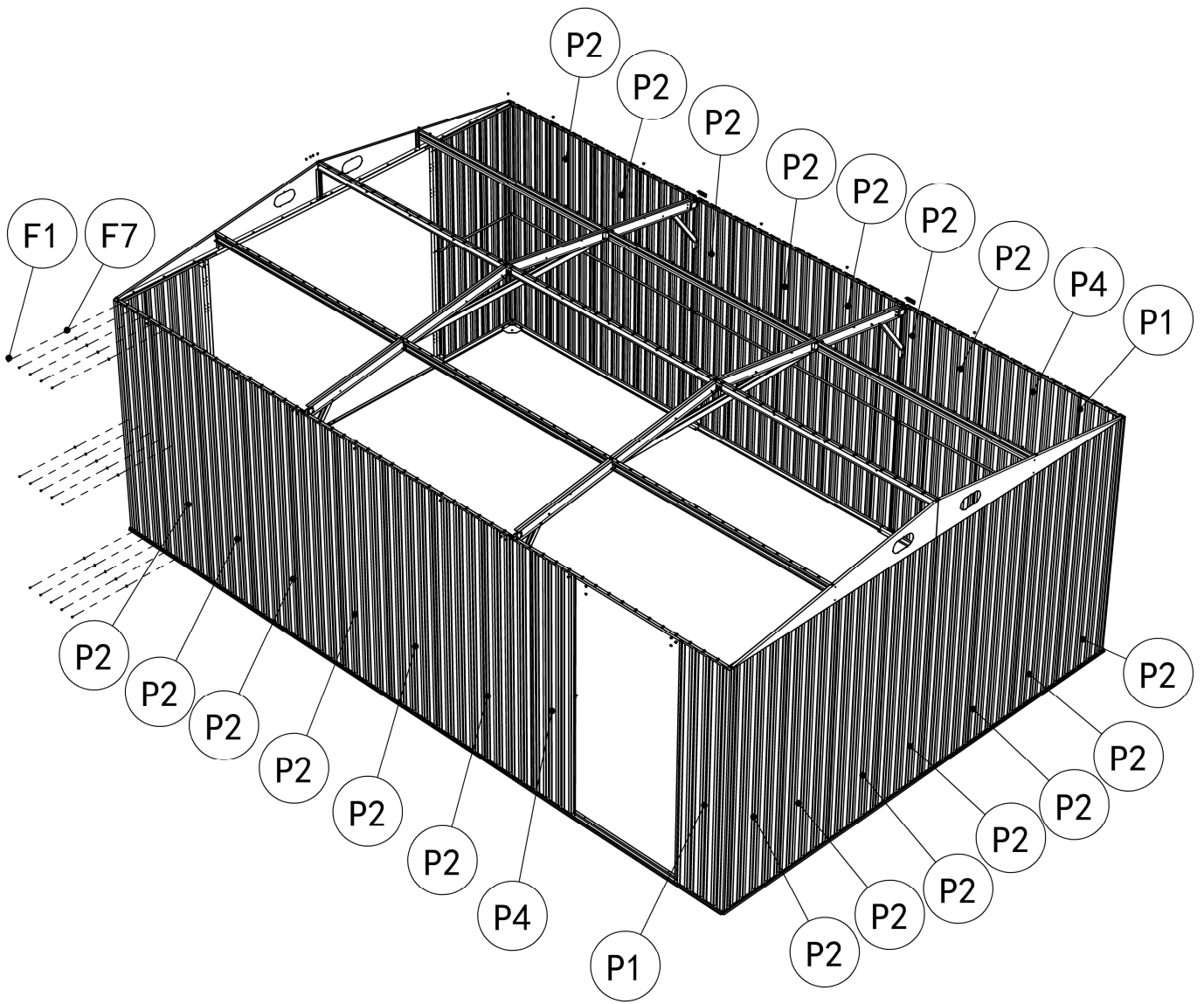

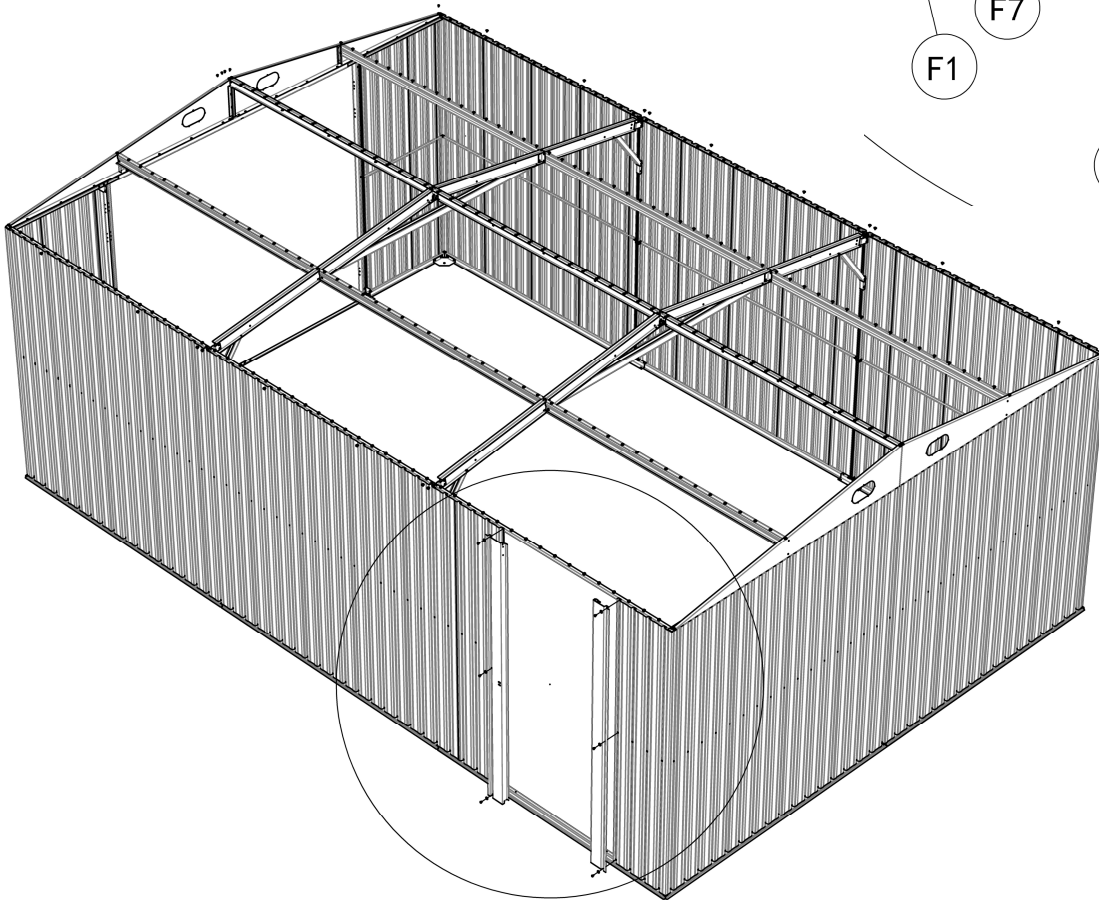
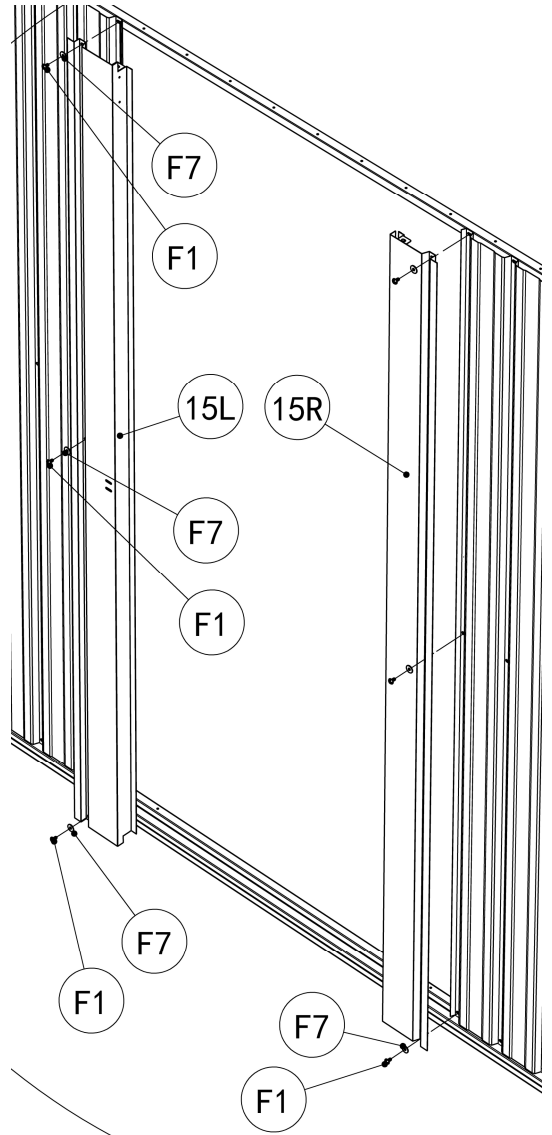
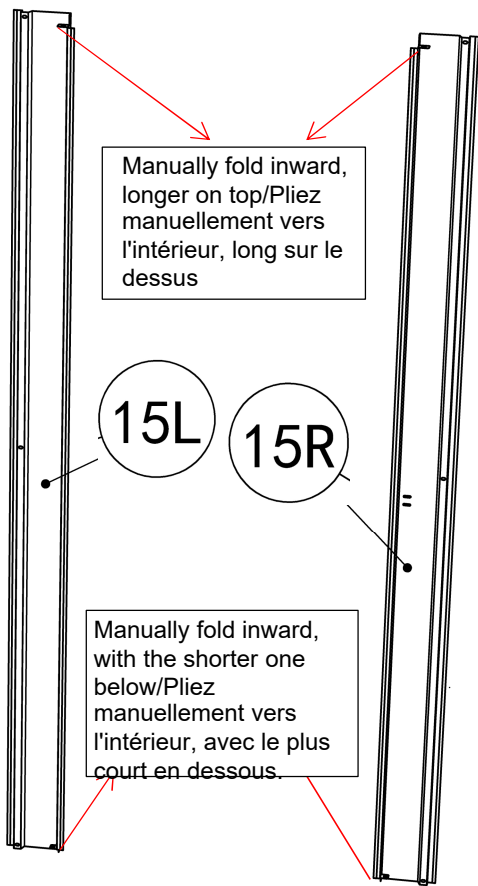

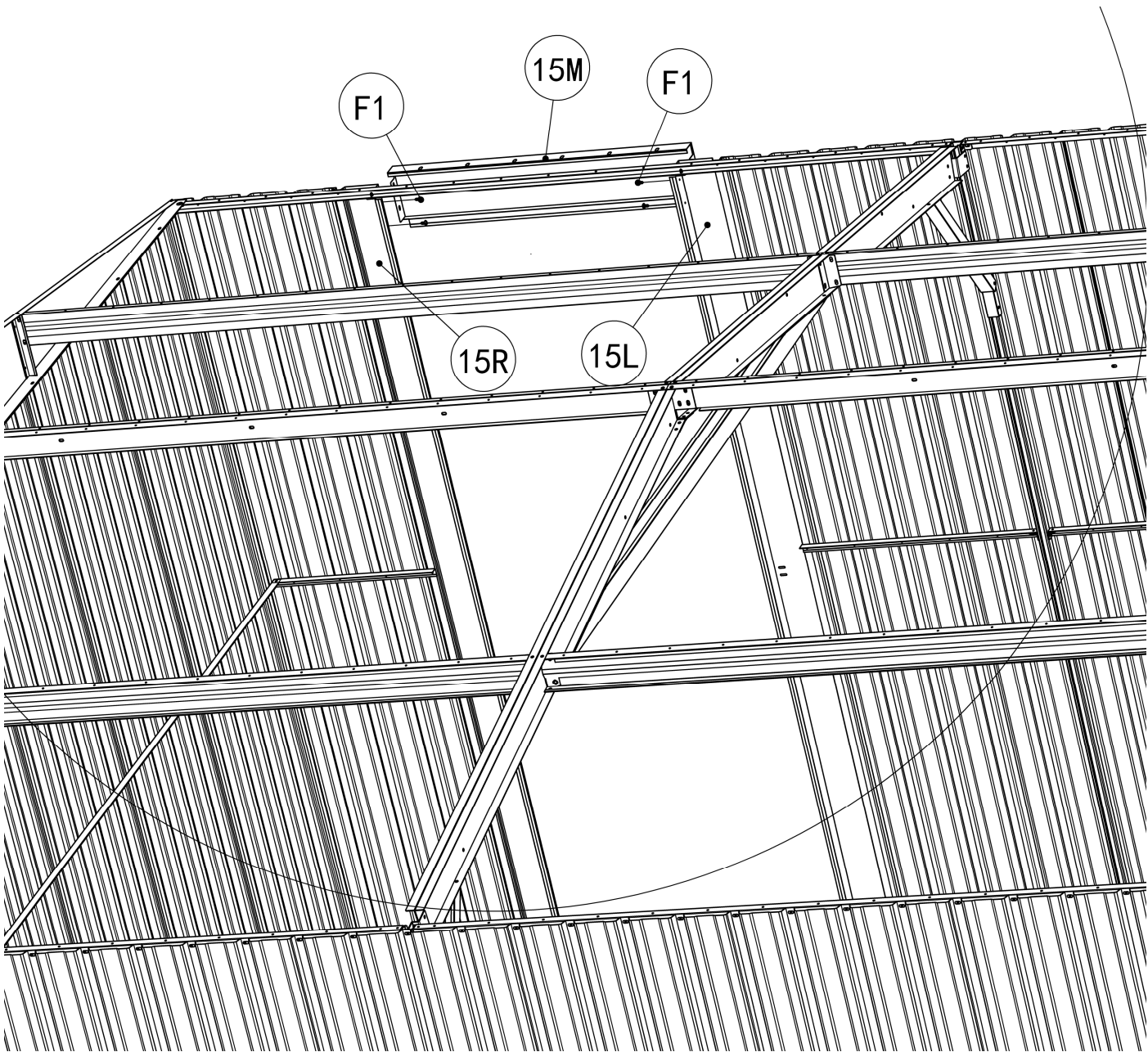

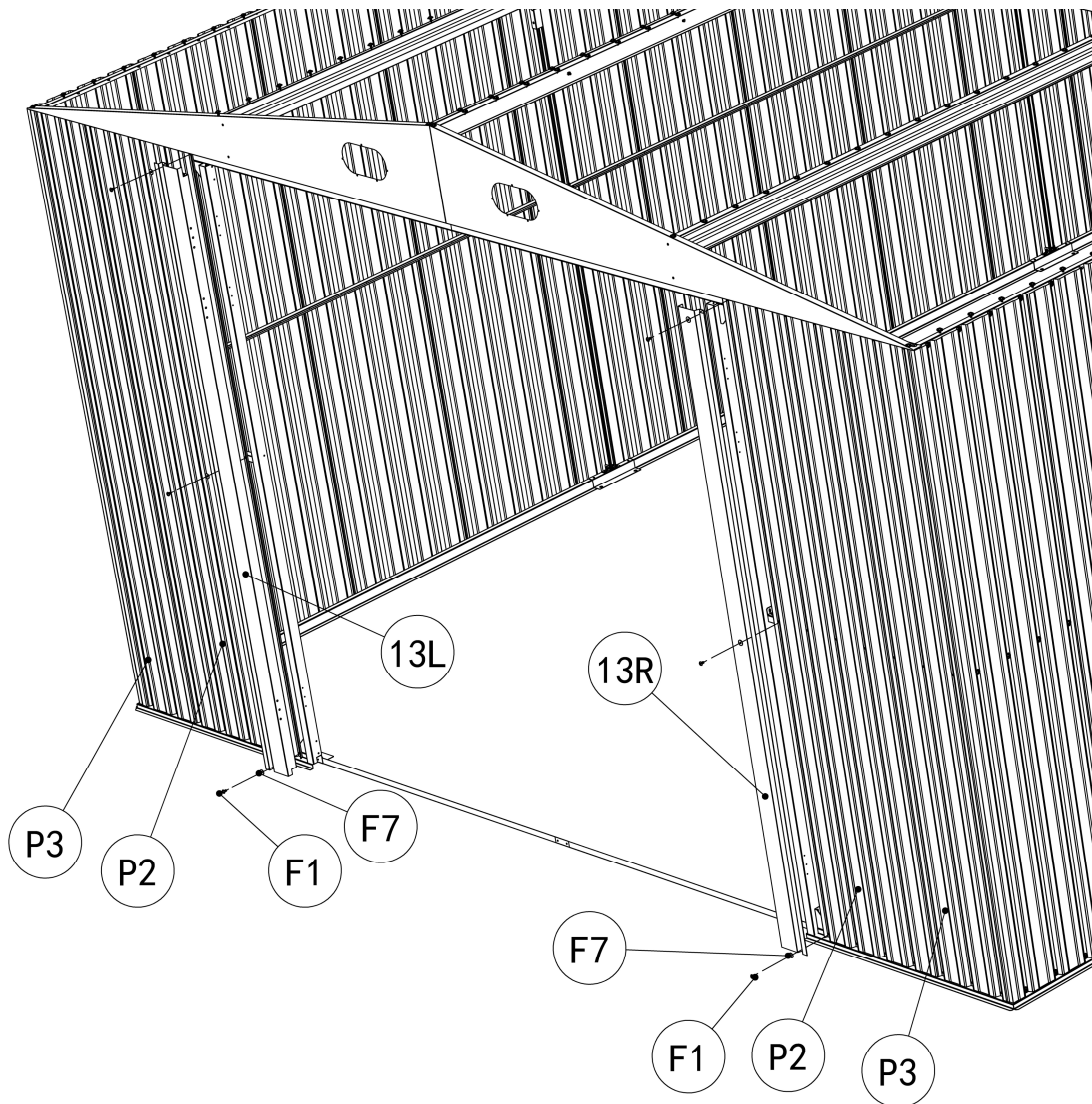
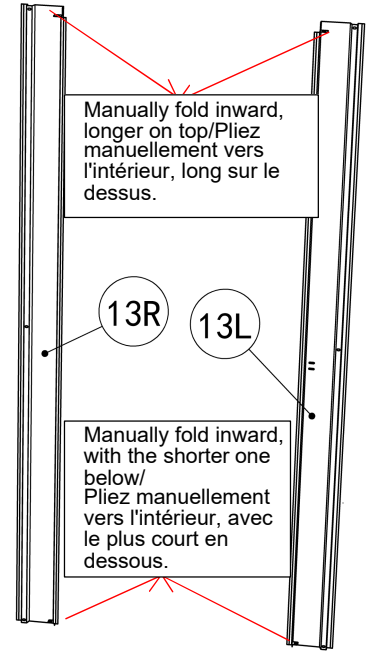
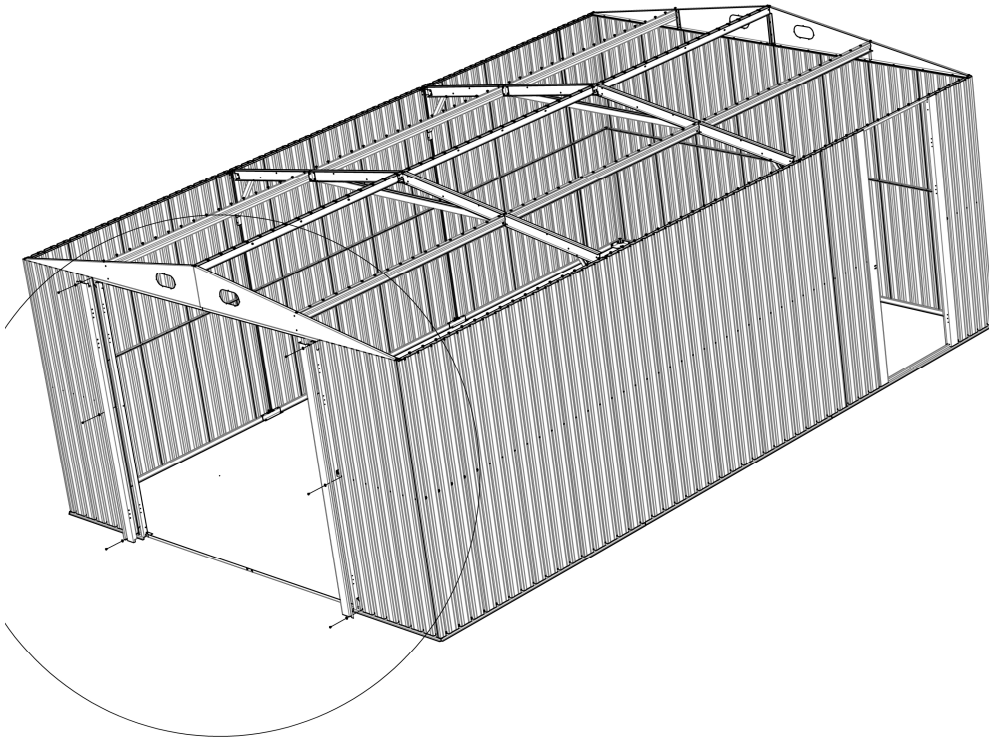

## 5. Roof Panel Assembly/Assemblage du panneau de toit

1. Fix GF with F4 on APL and APR;
2. Install AP2 onto ABR, ABL, CR, CL, ABM, CM, and secure with F1 and F7. For every 4 AP2 installed, install AP5 onto AP2 and secure with F1 and F7;
3. Insert C4 into the middle hole between the first and last panels, and fix it with F1 and F7;
4. Fix AP6, RT3, RC2, AP7, AP8, and RC3 with F1 and F7.

1. Corrigez GF avec F4 sur APL et APR
2. Installez AP2 sur ABR, ABL, CR, CL, ABM, CM et sécurisez avec F1 et F7  
Pour chaque 4 AP2 installés, installez AP5 sur AP2 et sécurisez avec F1 et F7.
3. Insérez C4 dans le trou central entre le premier et le dernier carreau et fixez-le avec F1 et F7
4. Corrigez AP6, RT3, RC2, AP7, AP8 et RC3 avec F1 et F7

Part	No	Qty	Part	No	Qty	Part	No	Qty
	AP2	26		F1	328		F7	312
	AP7	4		RC2	4		AP5	3
	RC3	4		AP6	4		C4	4
	AP8	2		RT3	2		GF	4
	F4	20						

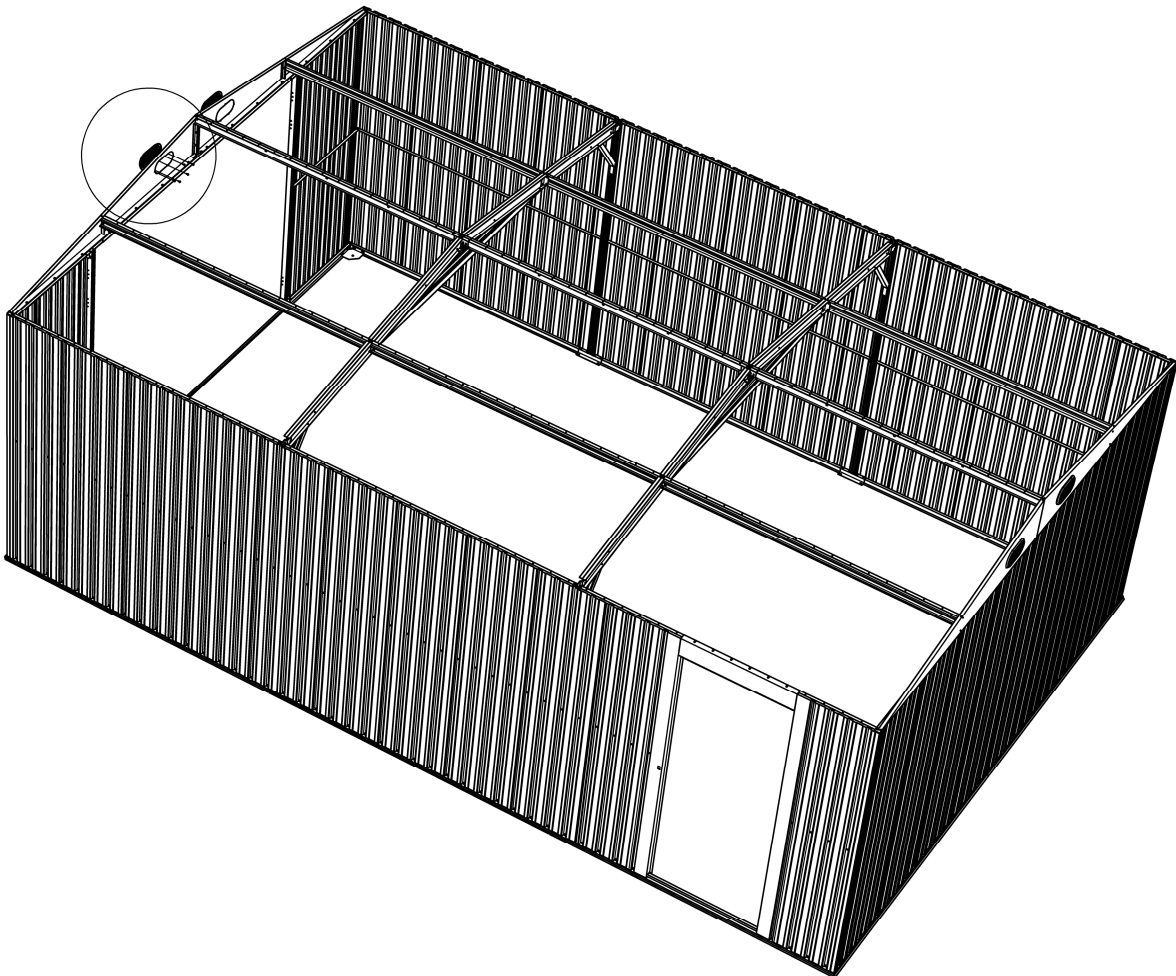
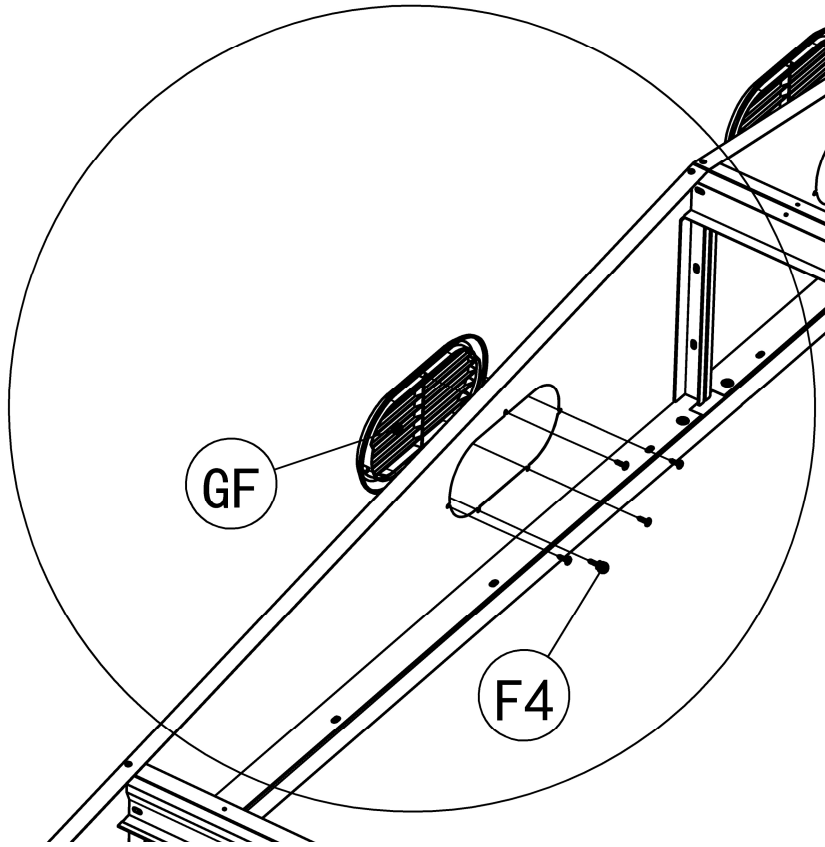

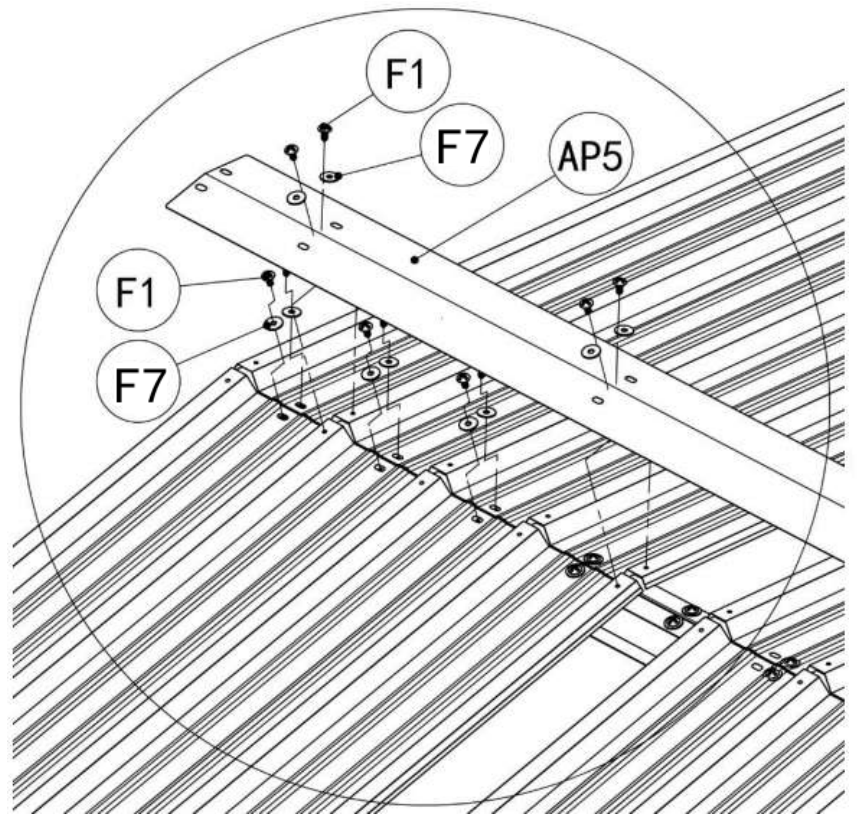
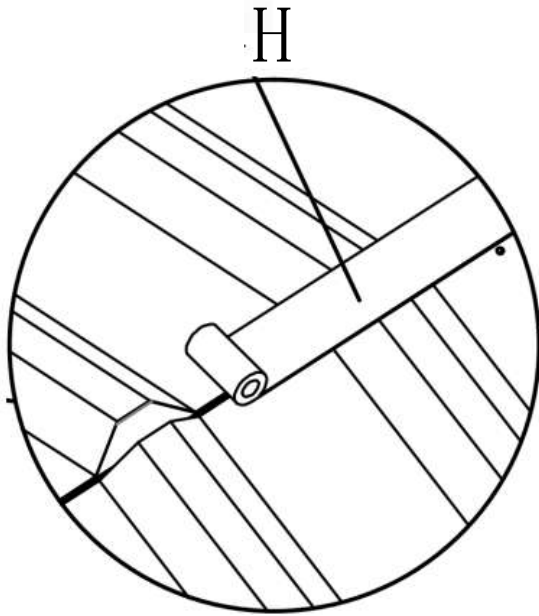

Apply waterproof tape first before install AP5./Appliquez d'abord du ruban étanche avant d'installer AP5.

Whenever four AP2 modules are installed, start installing AP5 and secure with F1 and F7./Chaque fois que quatre modules AP2 sont installés, commencez à installer AP5 et sécurisez avec F1 et F7.

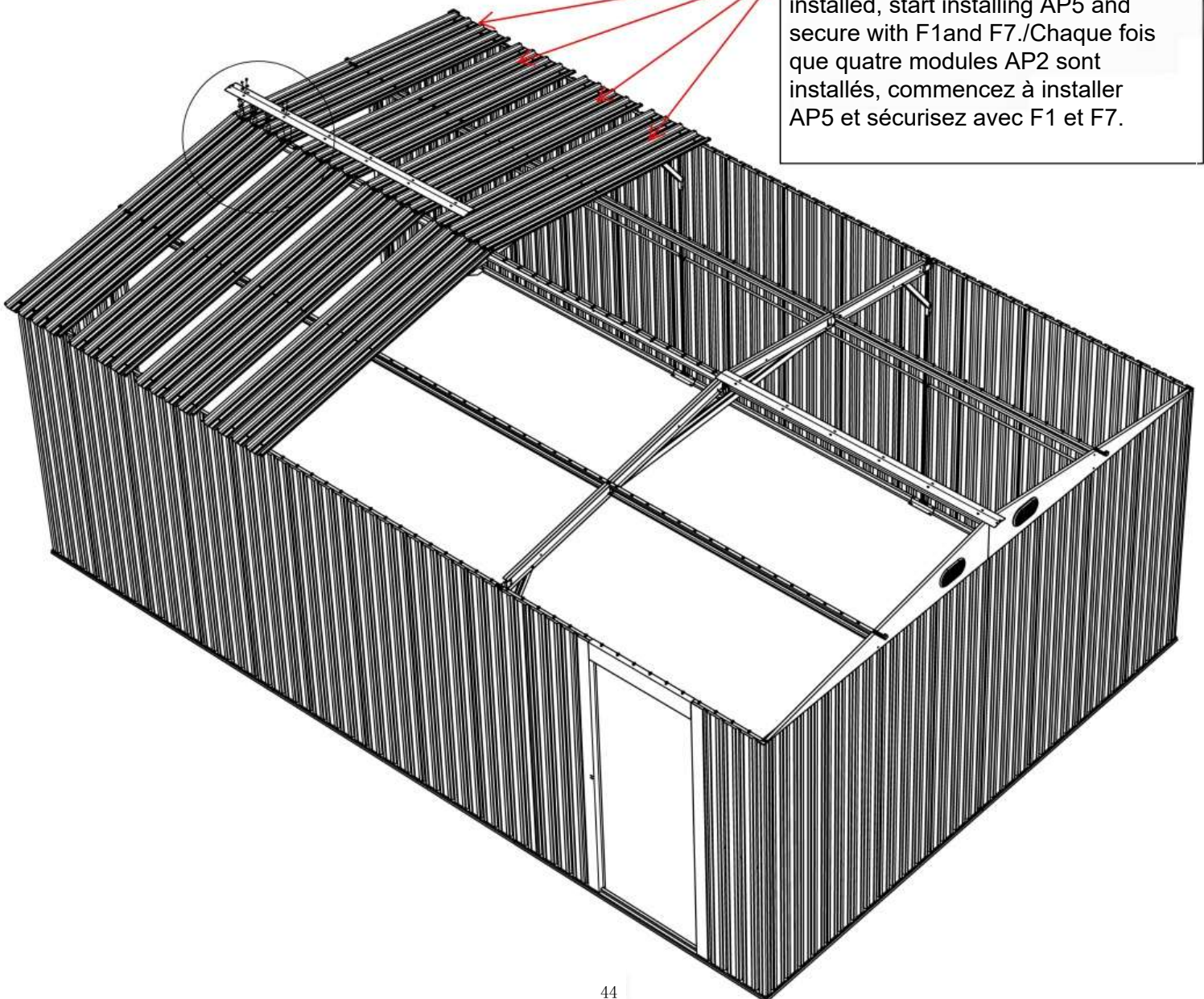

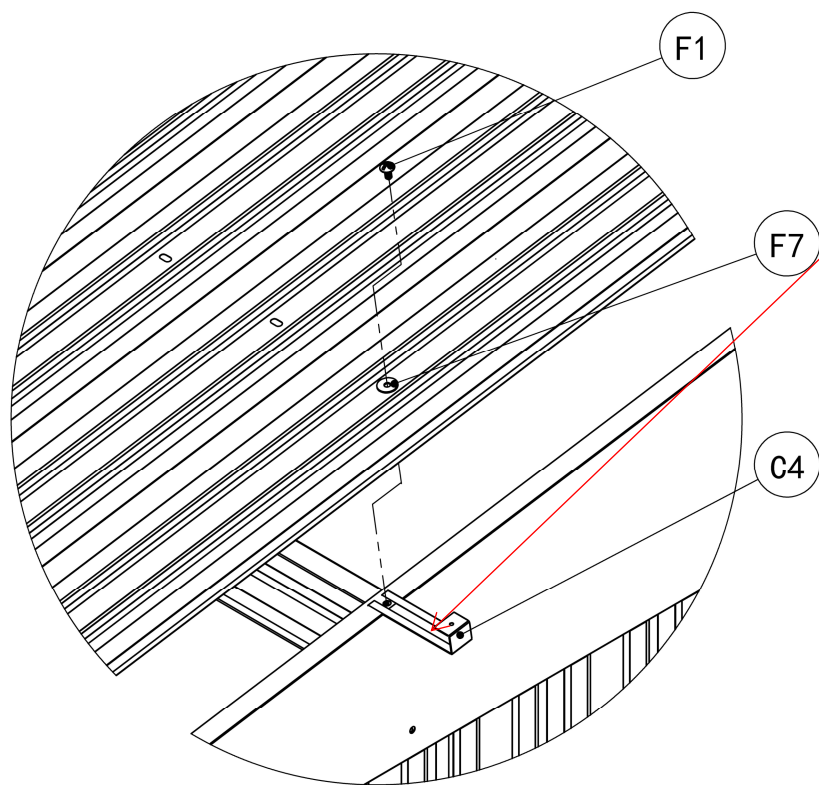
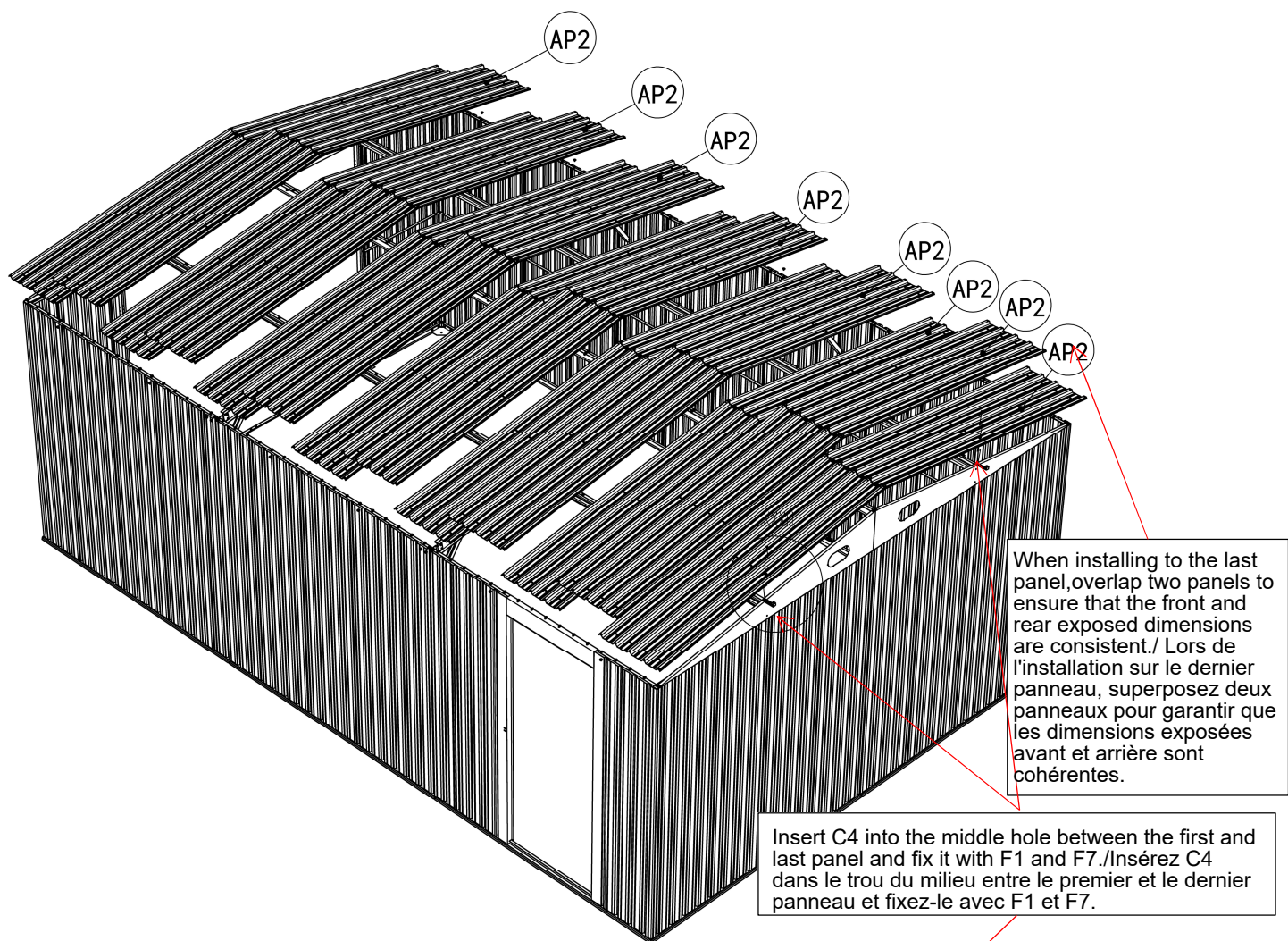

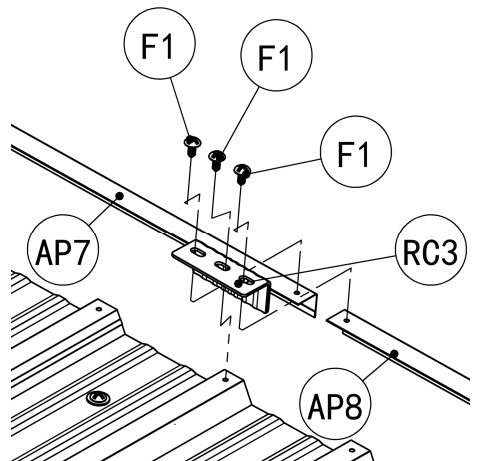
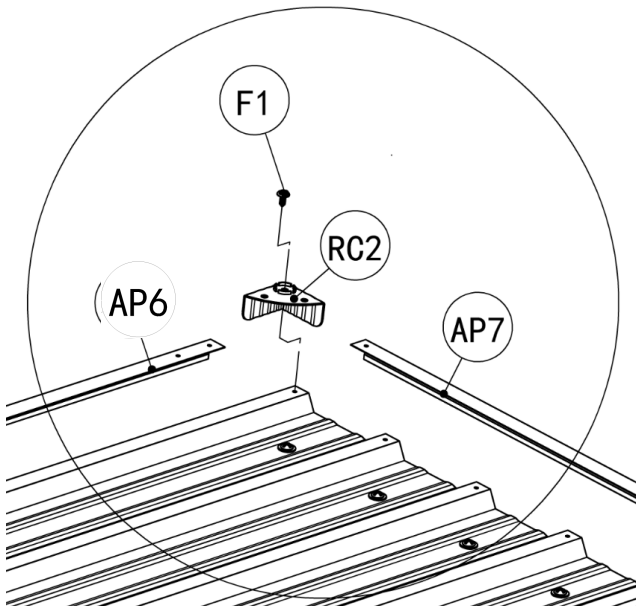
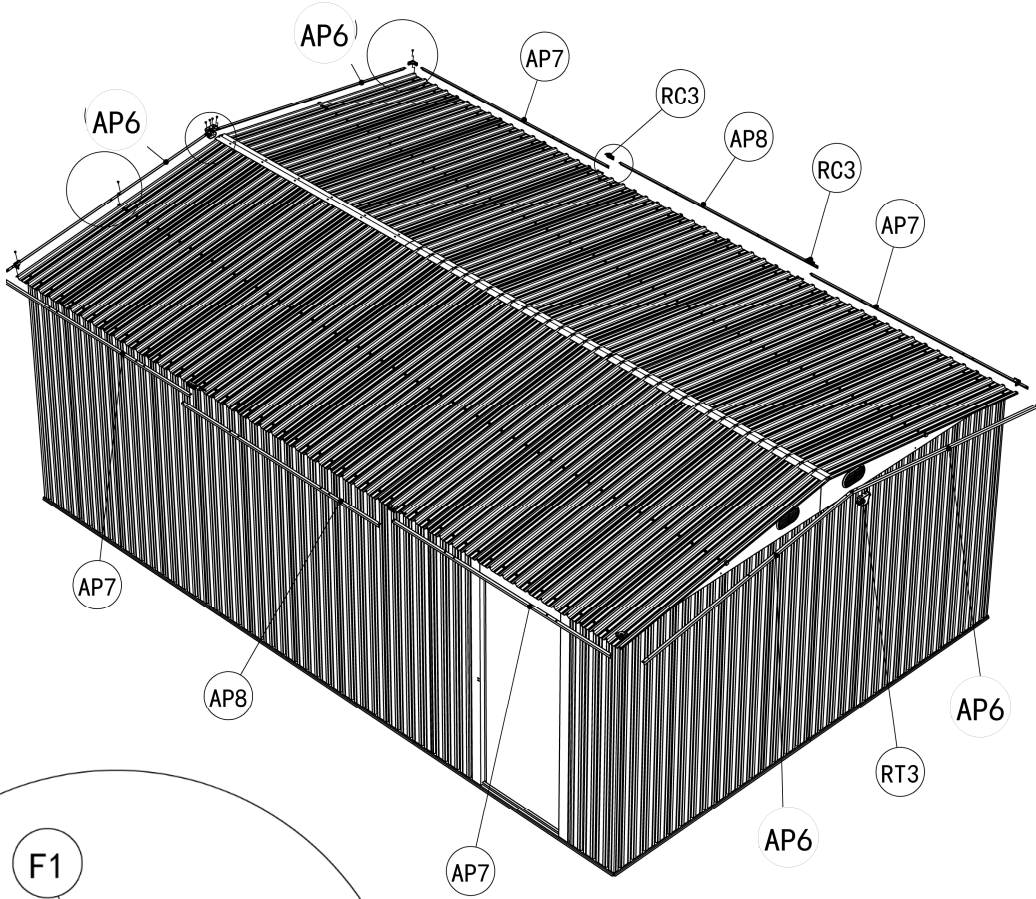
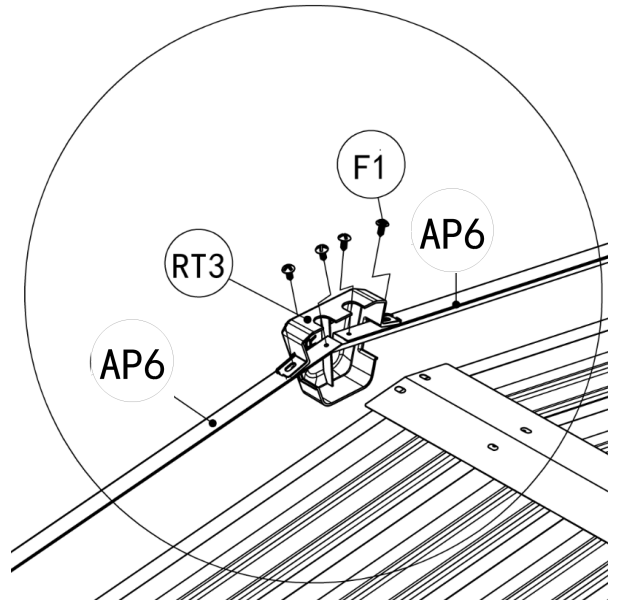
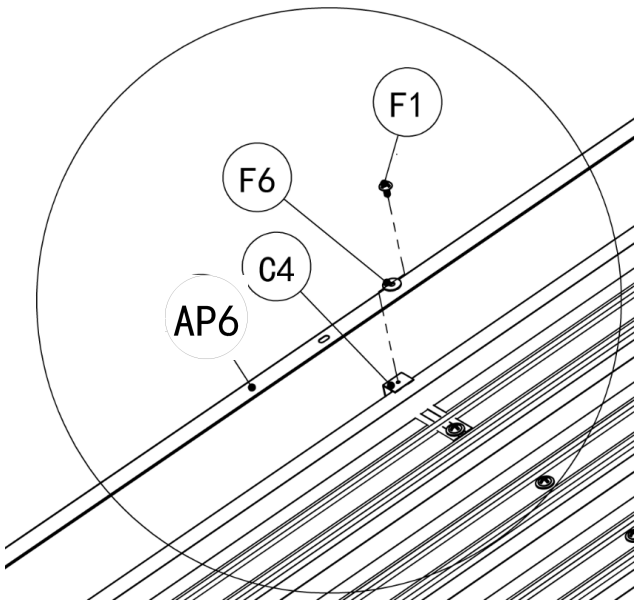

## 6. Door Assembly/Assemblage de la porte

(1) Side installation: Connect D15, D21, D16, D17, and D18, and fix them with F13 and F6; Flip the assembly to the back, install D19, D20, and fix them with F11, F13, and F6; Flip over to the front and install GB, secure with F11; Install D9 and secure with F13 and F6; Fix S1 with F11;

























(2) Left door installation: Connect D1, D4, D2, D5, D6, D12 and fix them with F13 and F6; Flip the assembly to the back, install D7, D8, D11, D3, and D10 and fix them with F11, F13, and F6; Flip over to the front and install GB, D9, and fix them with F13, F6, F11; Fix S1 with F11; Fix GD with F11;

(3) Right door installation: Connect D2, D13, D14, D4, D12, D5 and fix them with F13 and F6; Flip the assembly to the back, install D7, D8, D3, and D10 and fix them with F11, F13, and F6; Flip over to the front and install GB, D9, and fix them with F13, F6, F11; Fix S1 with F11;

(1) Installation latérale : connectez D15, D21, D16, D17 et D18 et fixez-les avec F13 et F6 ; Retournez l'ensemble vers l'arrière, installez D19, D20 et fixez-les avec F11, F13 et F6 ; Retournez vers l'avant et installez GB, sécurisez avec F11 ; Installez D9 et sécurisez avec F13 et F6 ; Corrigez S1 avec F11

(2) Installation de la porte gauche : connectez D1, D4, D2, D5, D6, D12 et fixez-les avec F13 F6 ; Retournez l'ensemble vers l'arrière, installez D7, D8, D11, D3 et D10 et fixez-les avec F11, F13 et F6 ; Retournez vers l'avant et installez GB, D9 et corrigez-les avec F13, F6, F11 et F15 ; Corrigez S1 avec F11 ; Corrigez GD avec F11

(3) Installation de la porte droite : connectez D2, D13, D14, D4, D12, D5 et fixez-les avec F13 F6 ; Retournez l'assemblage vers l'arrière, installez D7, D8, D3 et D10 et fixez-les avec F11, F13 et F6 ; Retournez vers l'avant et installez GB, D9 et corrigez-les avec F13, F6, F11 ; Corrigez S1 avec F11 ;

Part	No	Qty	Part	No	Qty	Part	No	Qty
	D1	2		D5	1		D13	1
	D2	4		D6	1		D14	1
	D3	3		D7	4		D15	1
	D4	3		D8	4		D16	1
	D9	3		D11	1		D17	1
	D10	4		D12	2		D18	2
	D19	1		D21	1		F6	60
	D20	2		F13	60		GB	2
	F11	66						

# Side door installation/ Pose de porte latérale

The screws do not need to be locked tightly./ Il n'est pas nécessaire de serrer fermement les vis.

After adjusting the size to 29", lock it tightly./Après avoir ajusté la taille à 29", verrouillez-la fermement.

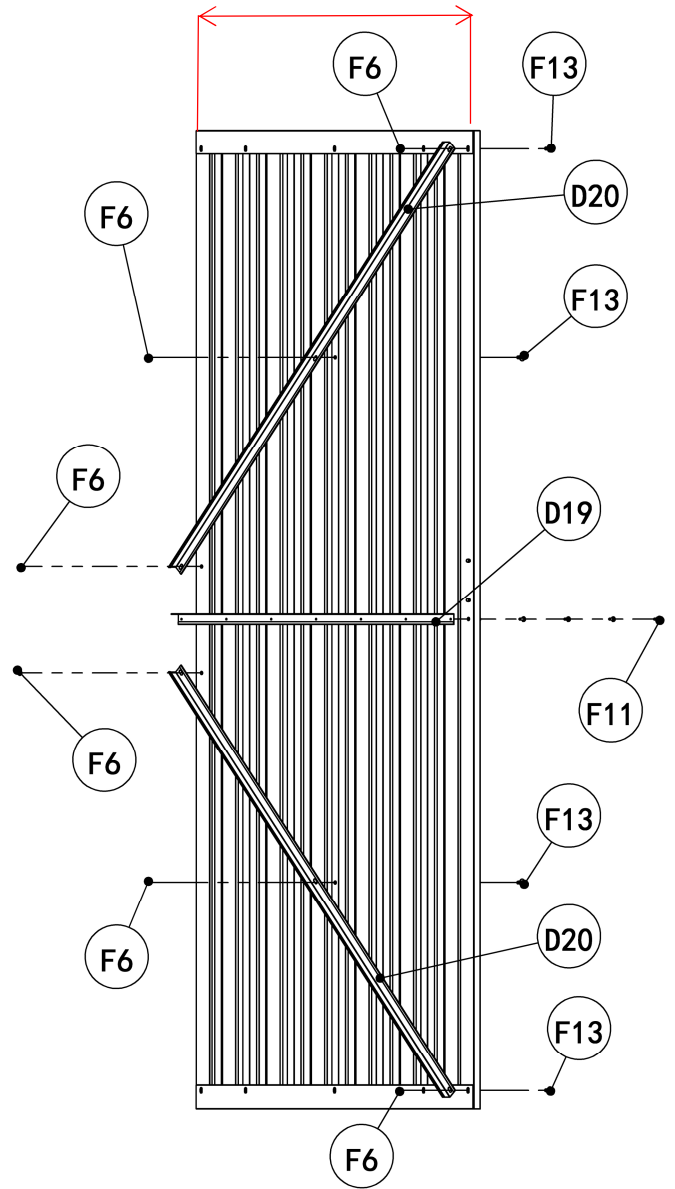
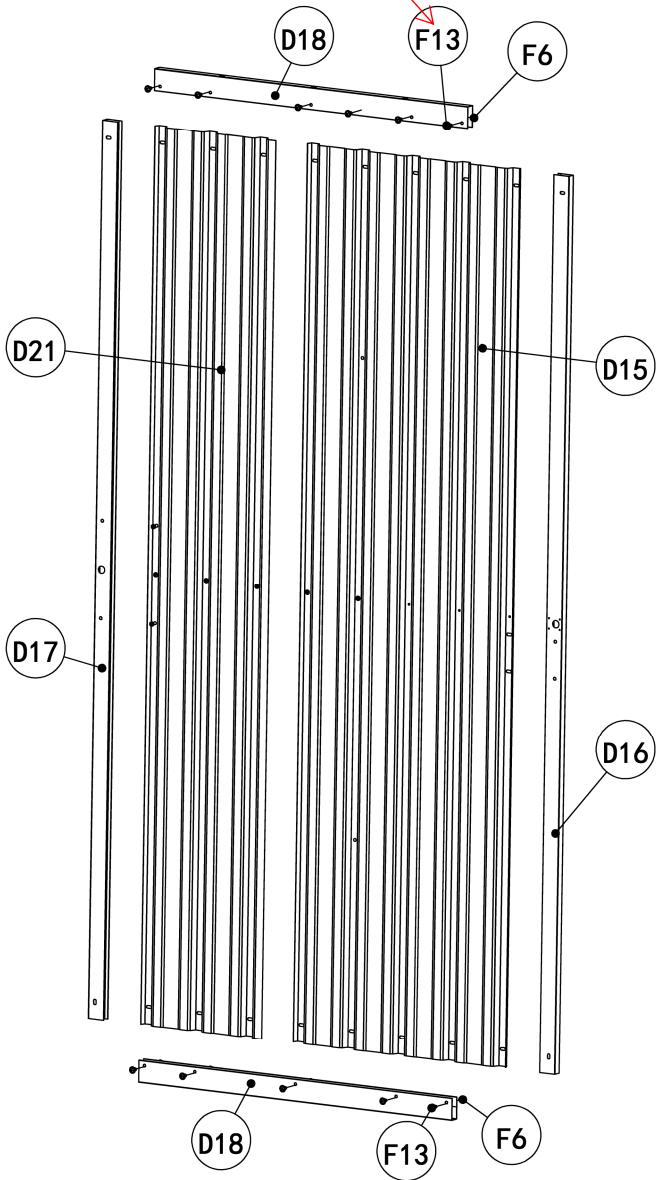

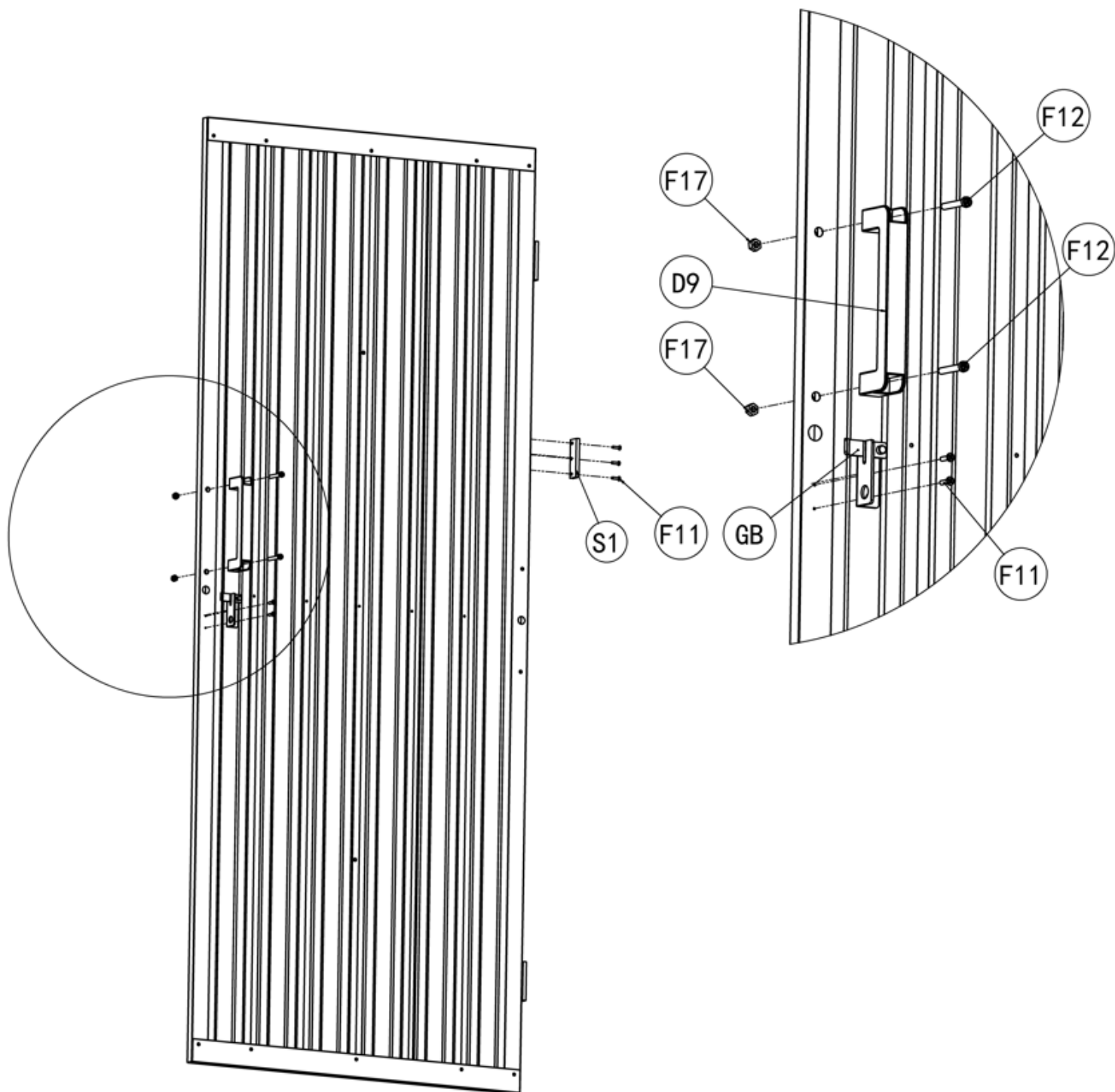

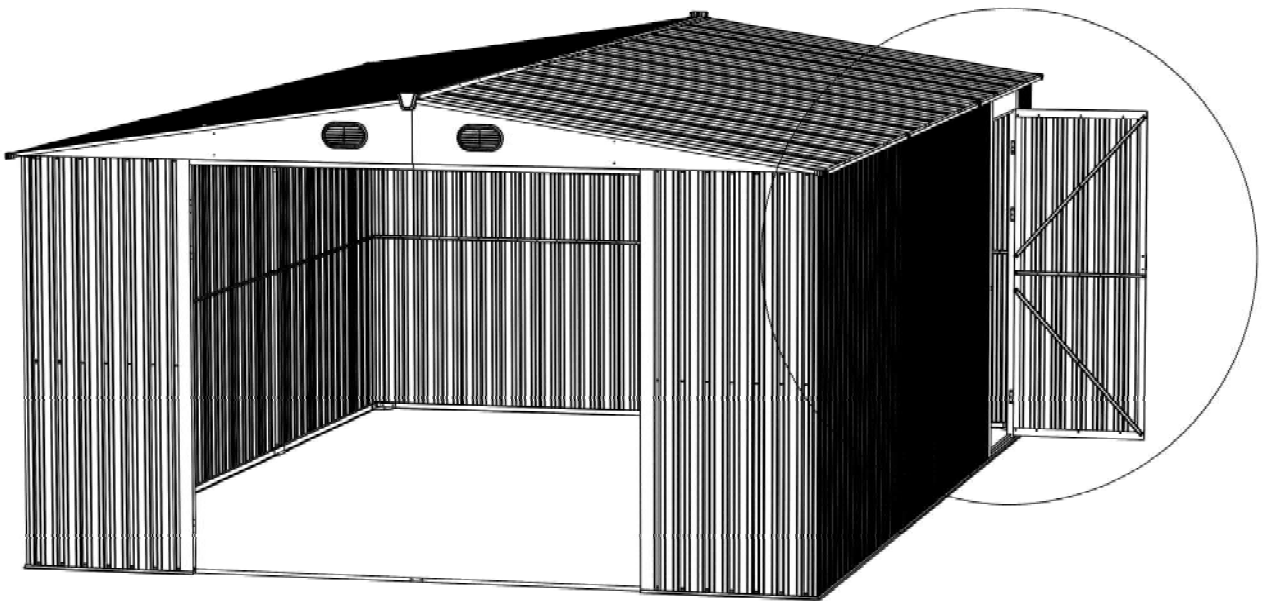
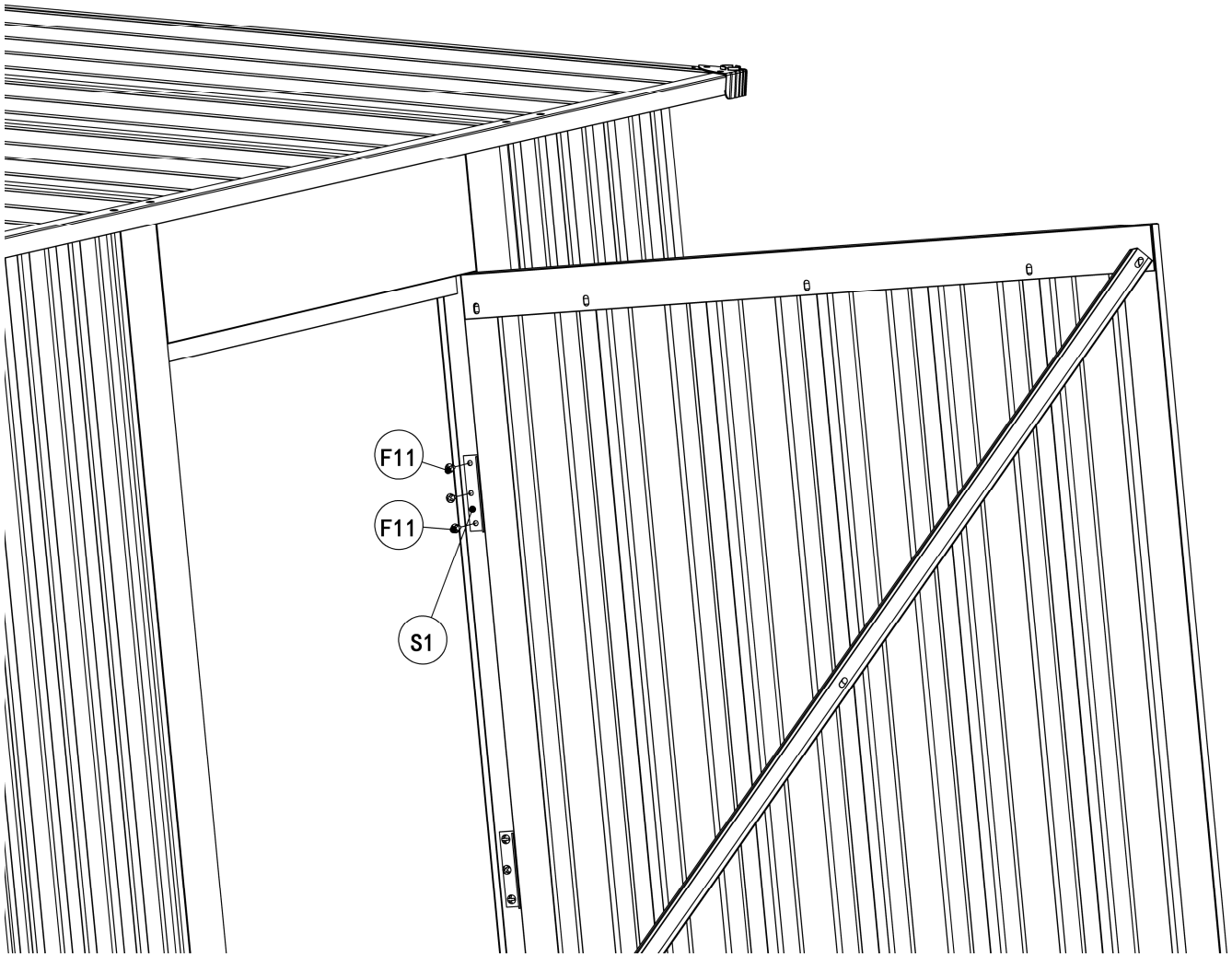

After aligning the lock buckle with the lock head, tighten the screws/Après avoir aligné la boucle de verrouillage avec la tête de verrouillage, serrez les vis

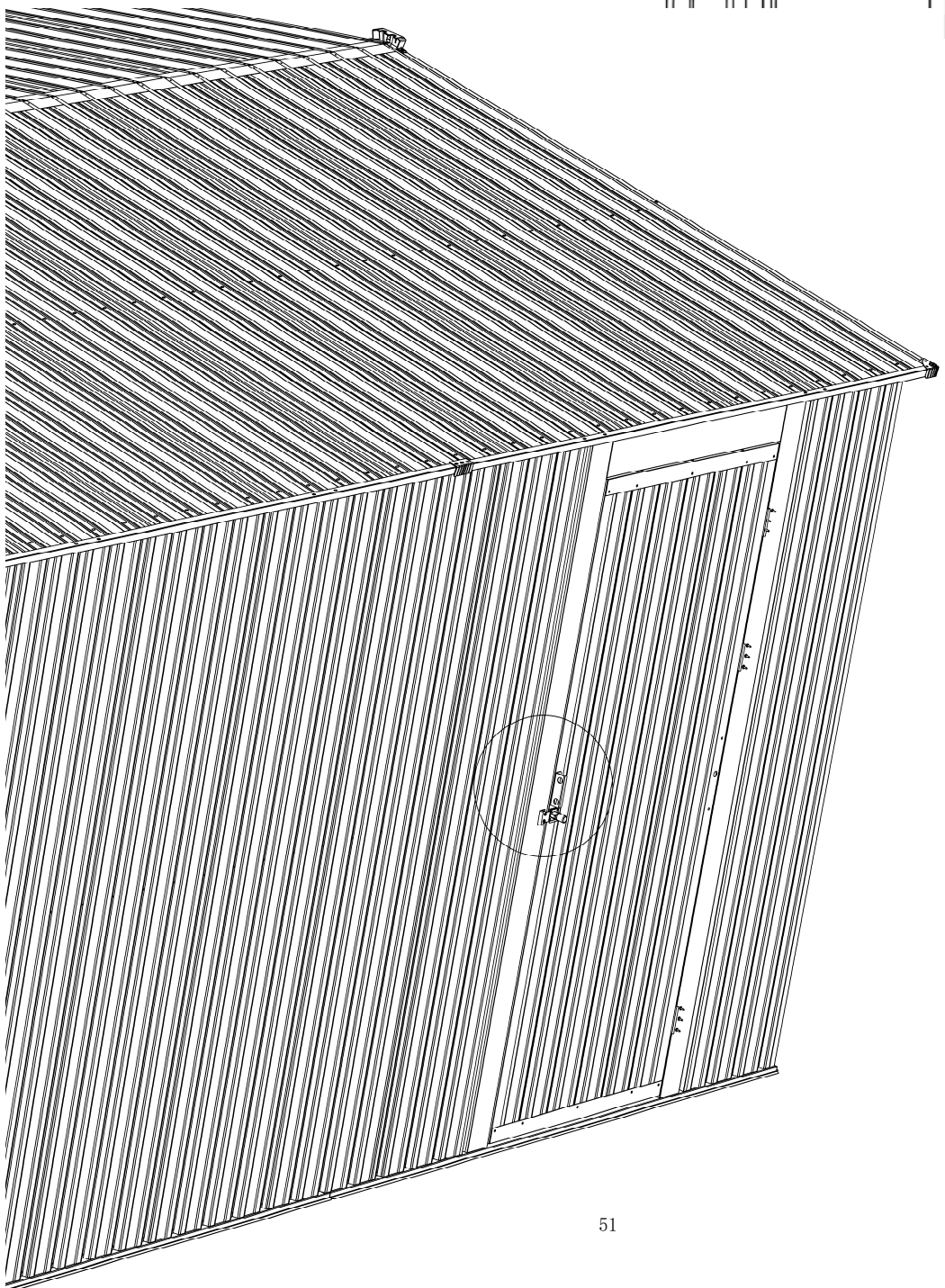
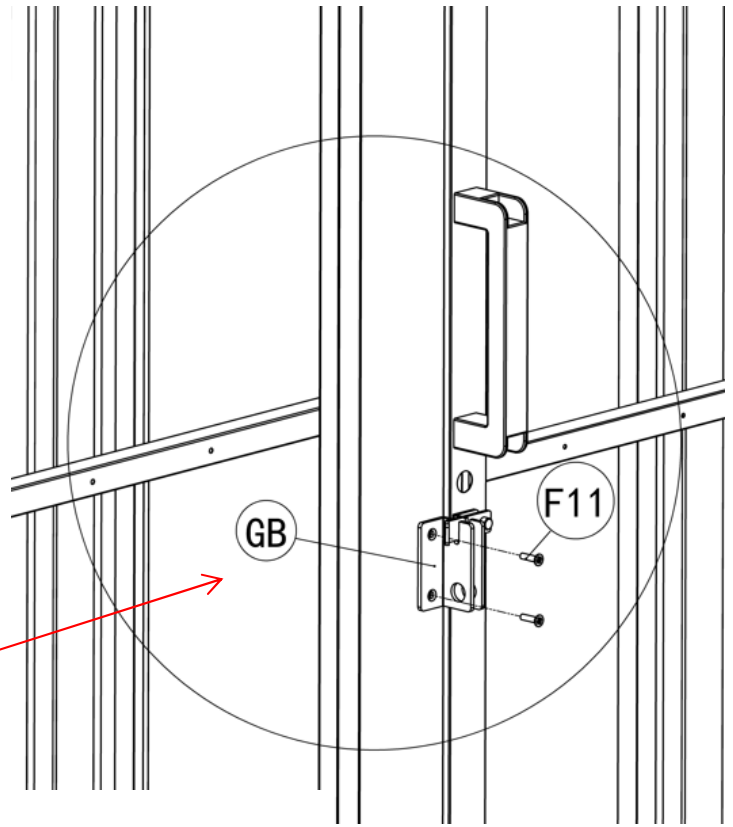

Left door installation  
Installation de la porte gauche

The screws do not need to be  
locked tightly//Il n'est pas nécessaire  
de serrer fermement les vis.

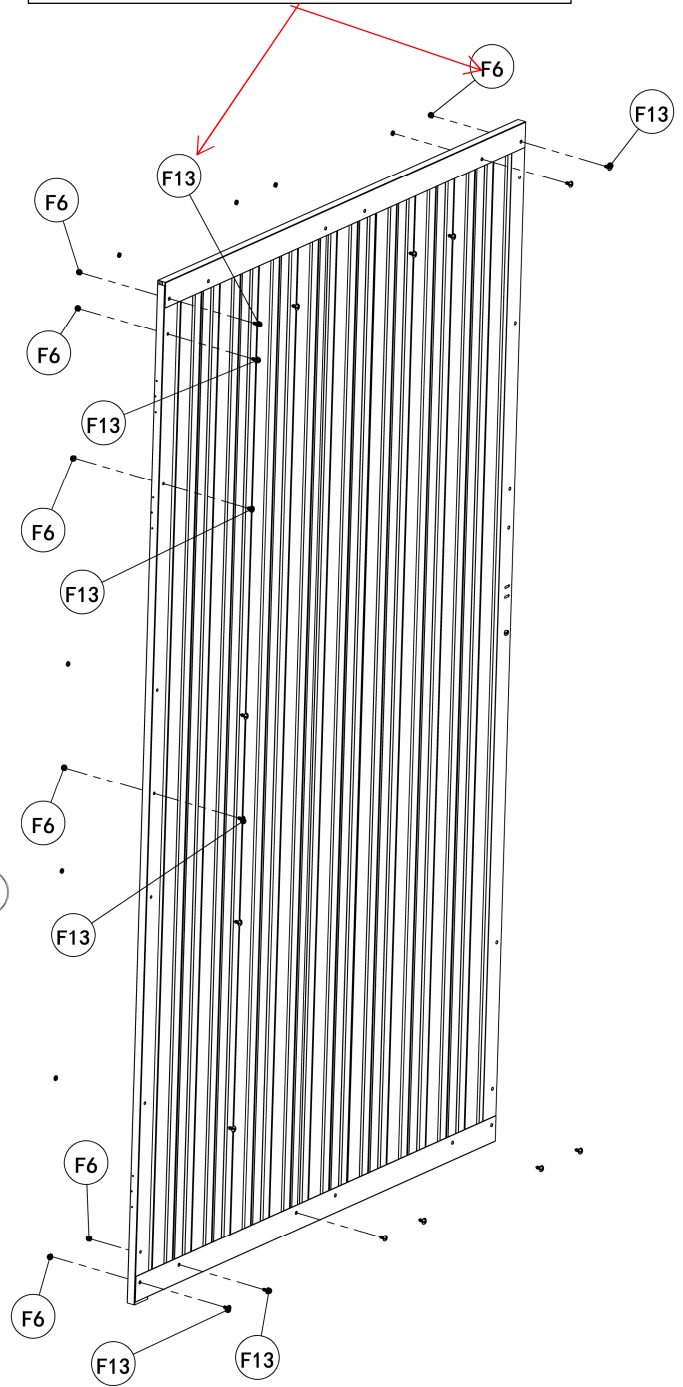
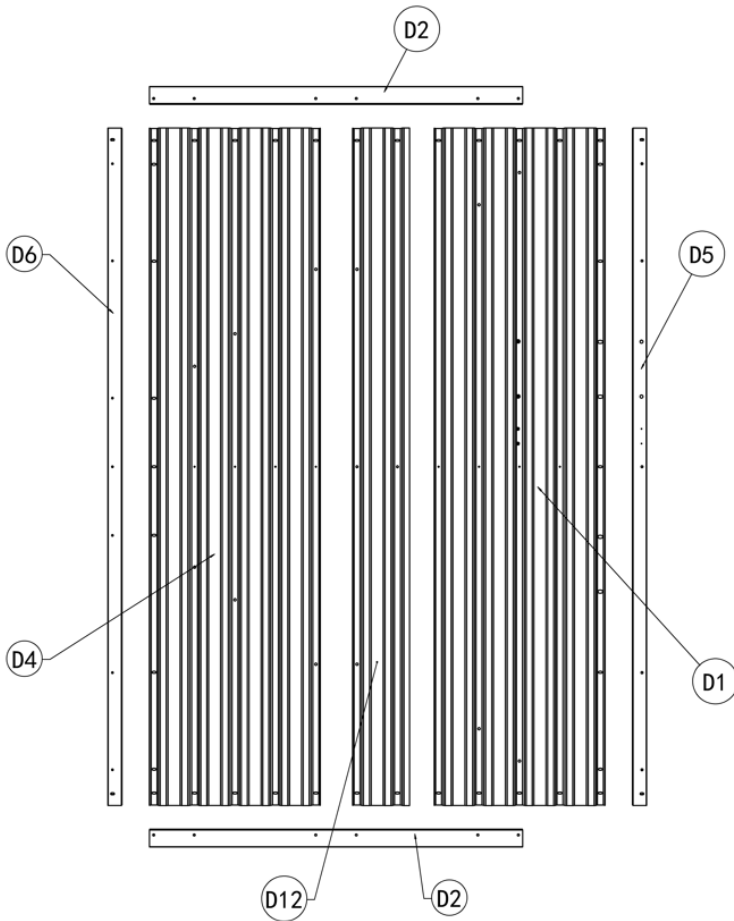

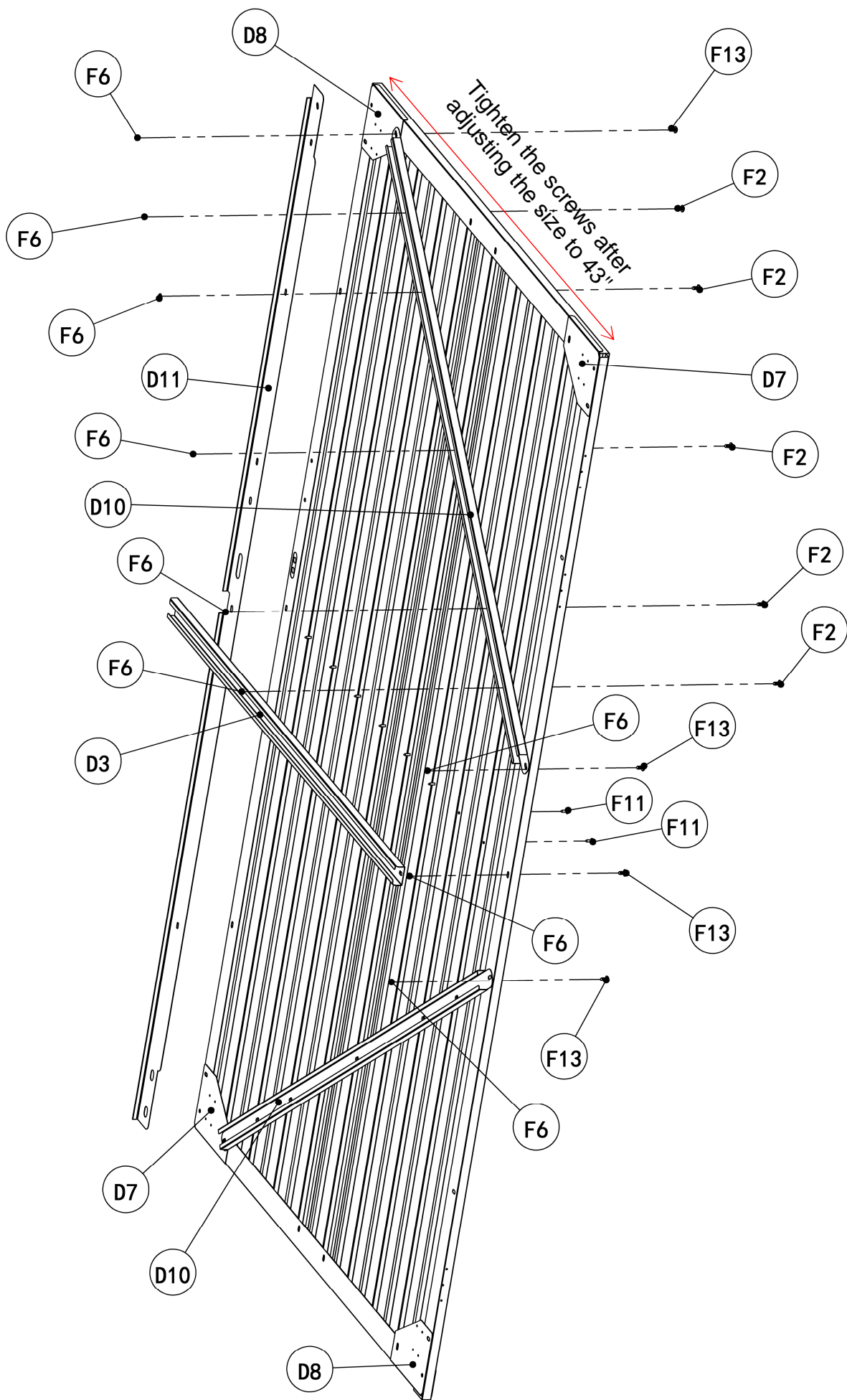

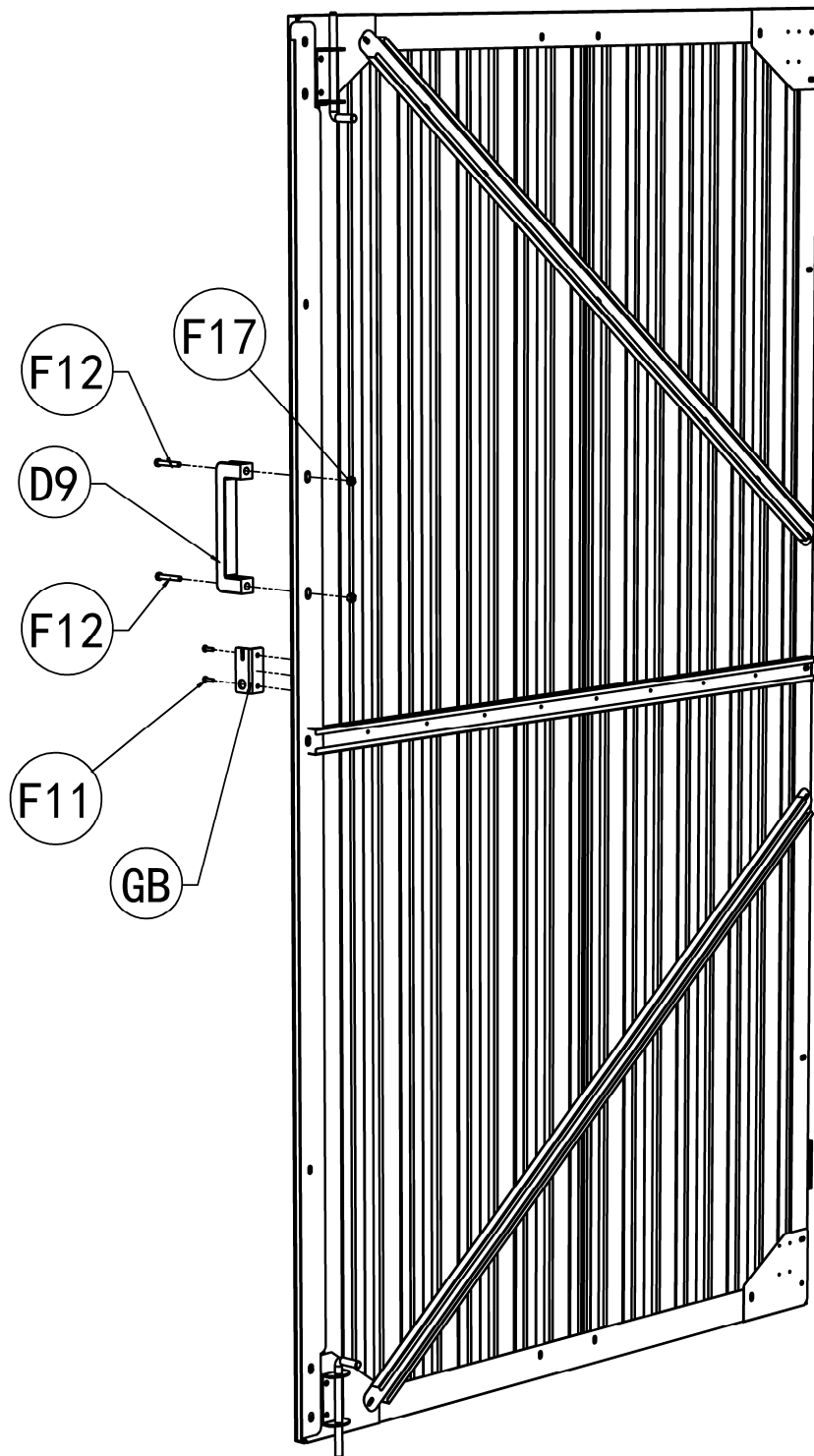

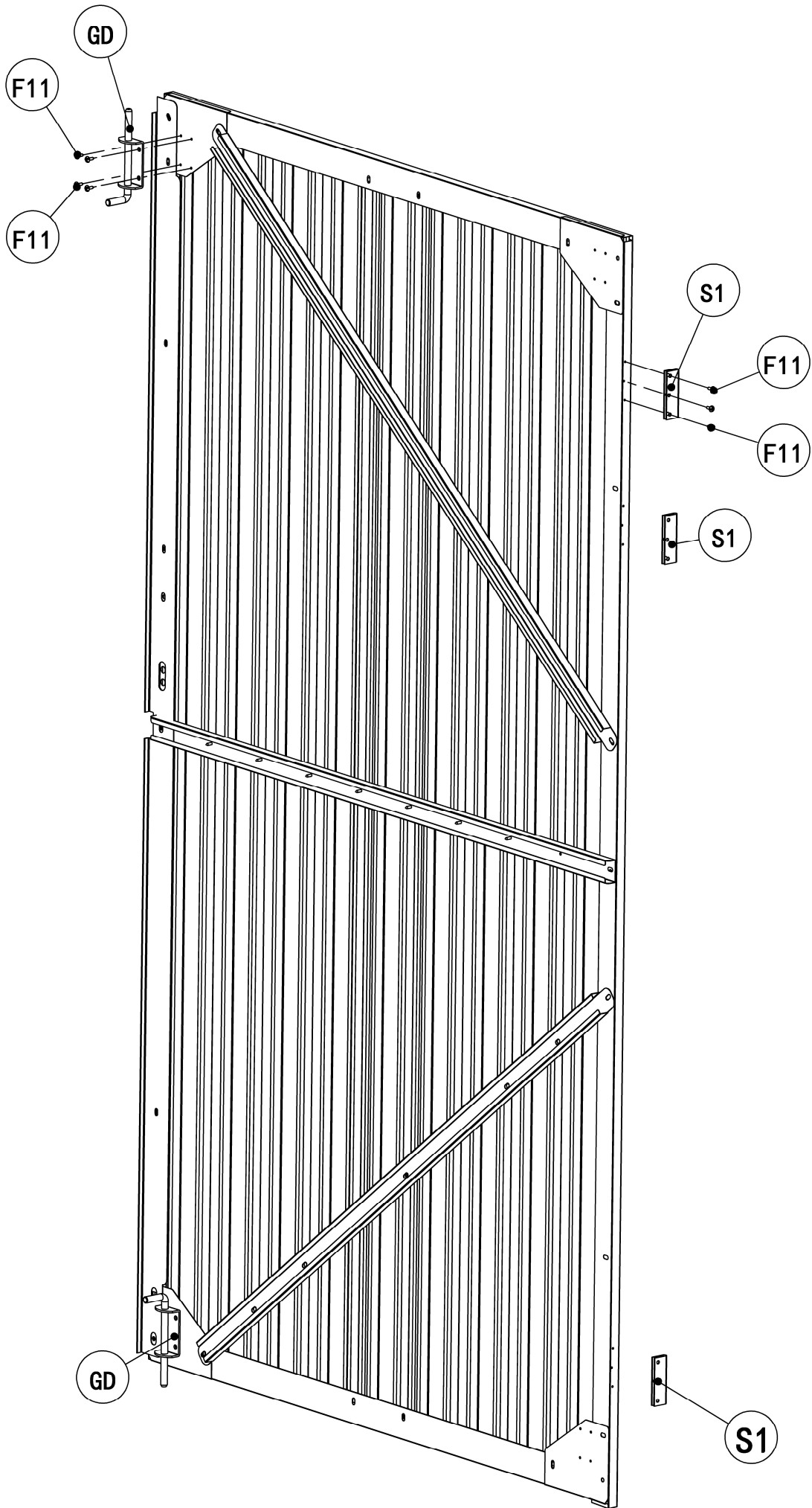

Right door installation  
Installation de la porte droite

The screws do not need to be locked tightly./Les vis n'ont pas besoin d'être fermement verrouillées

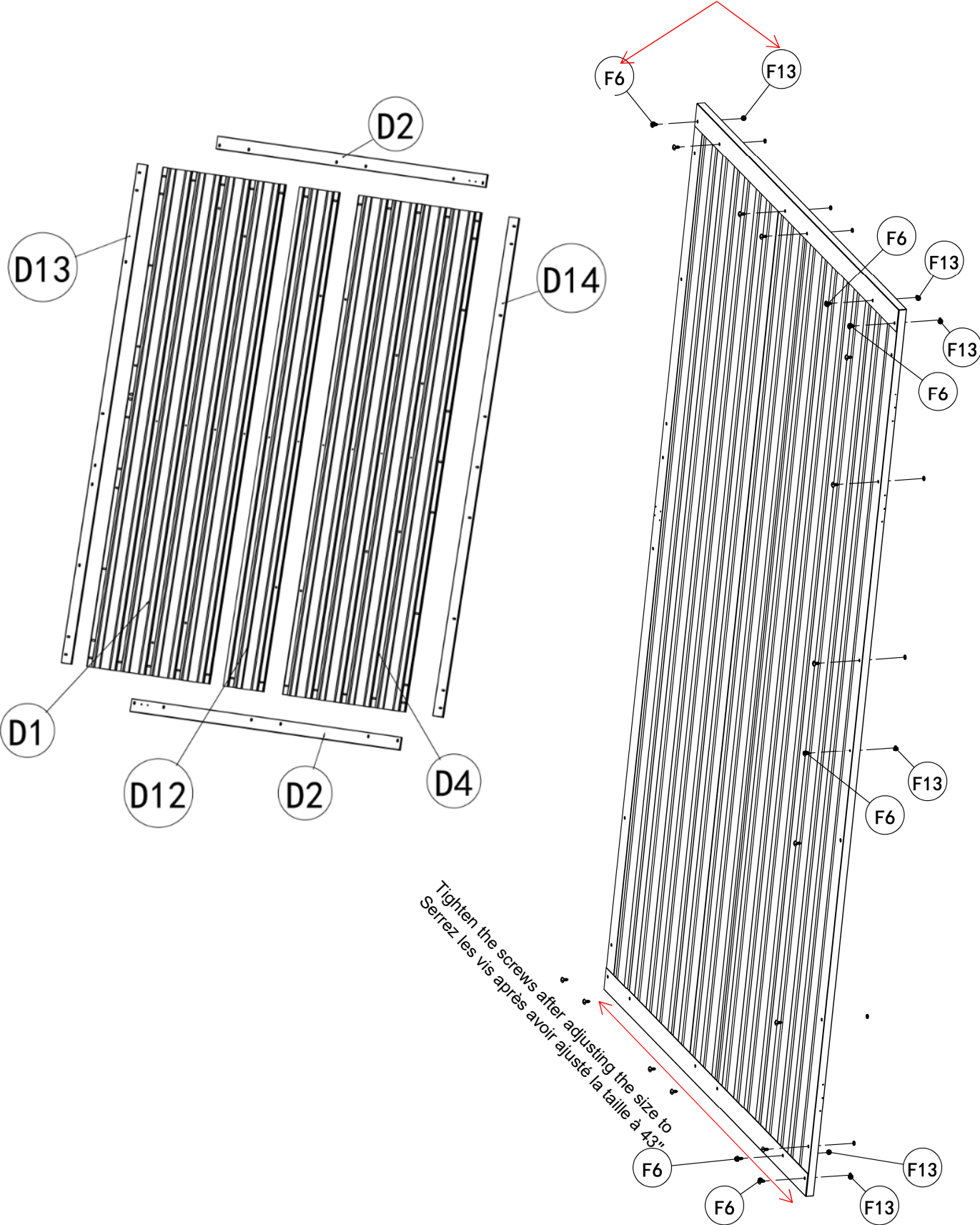

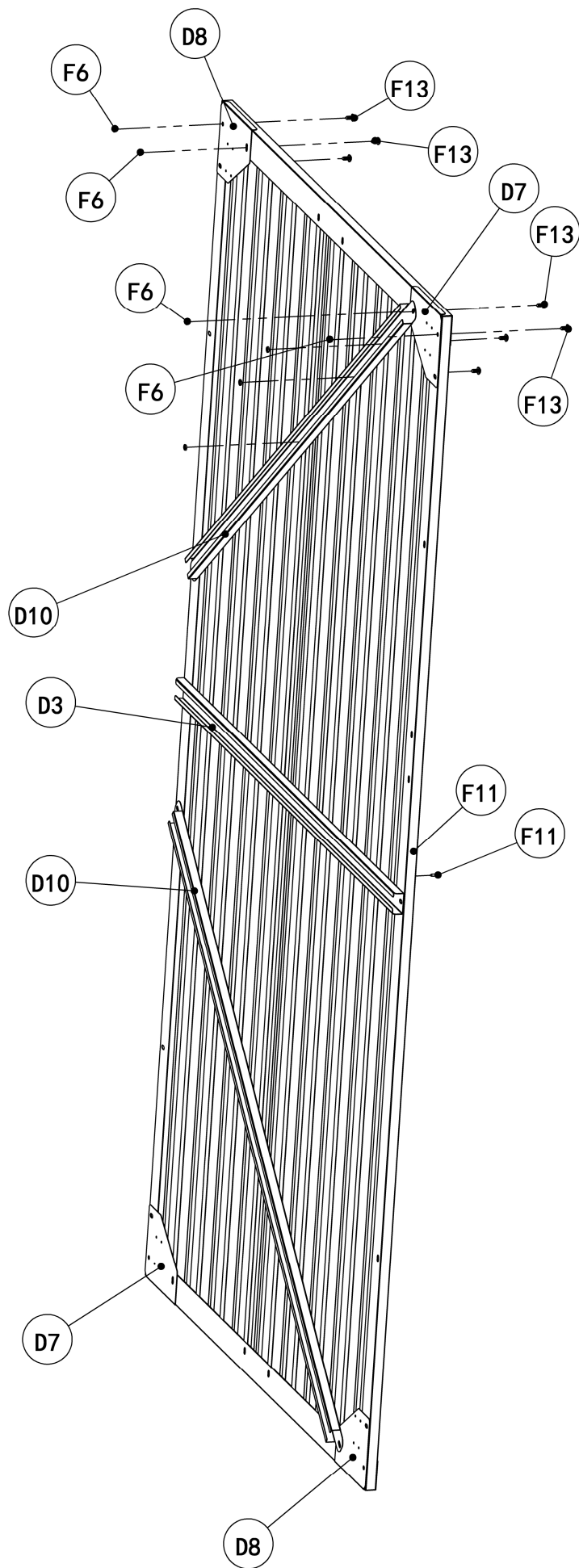

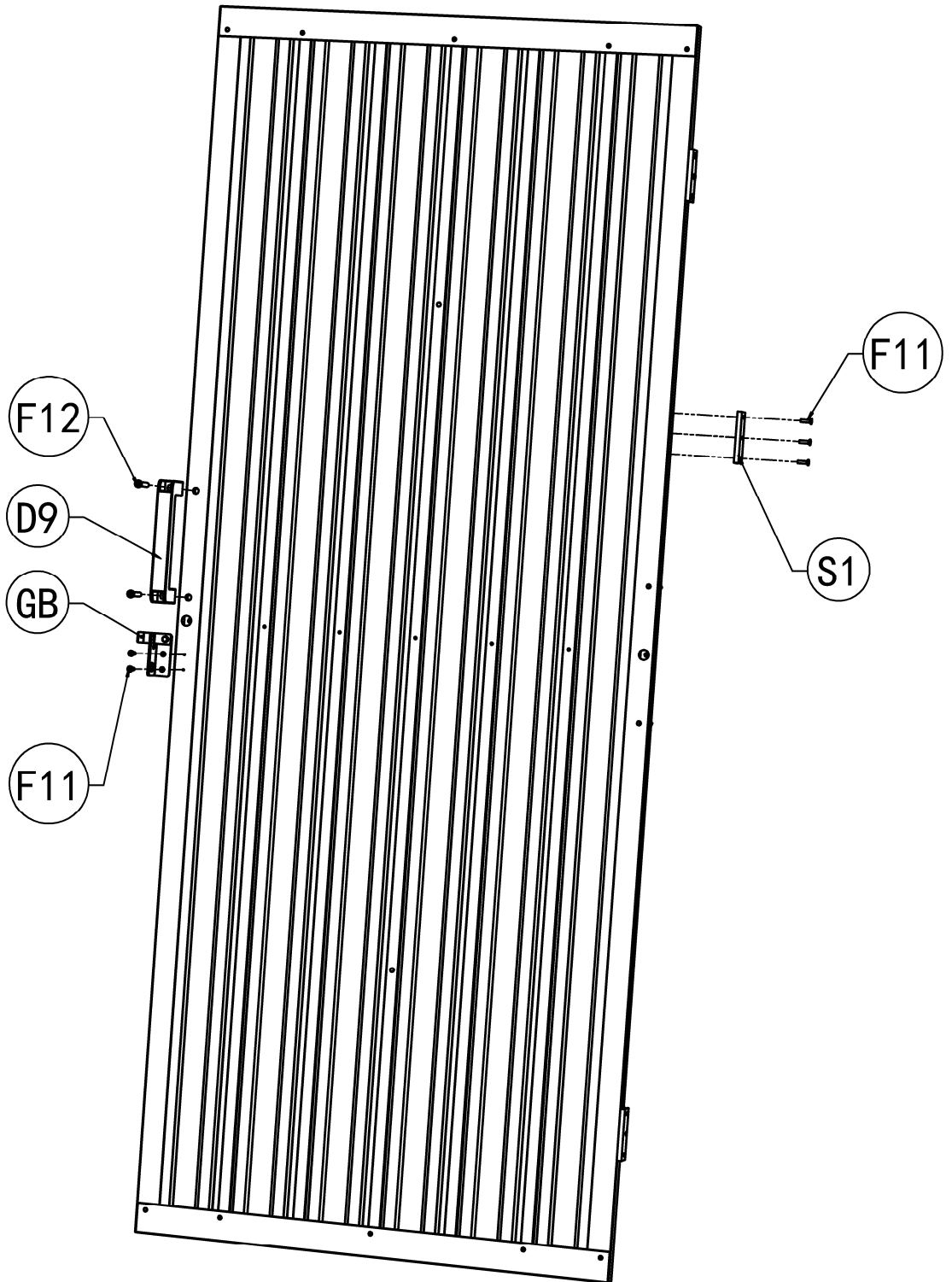

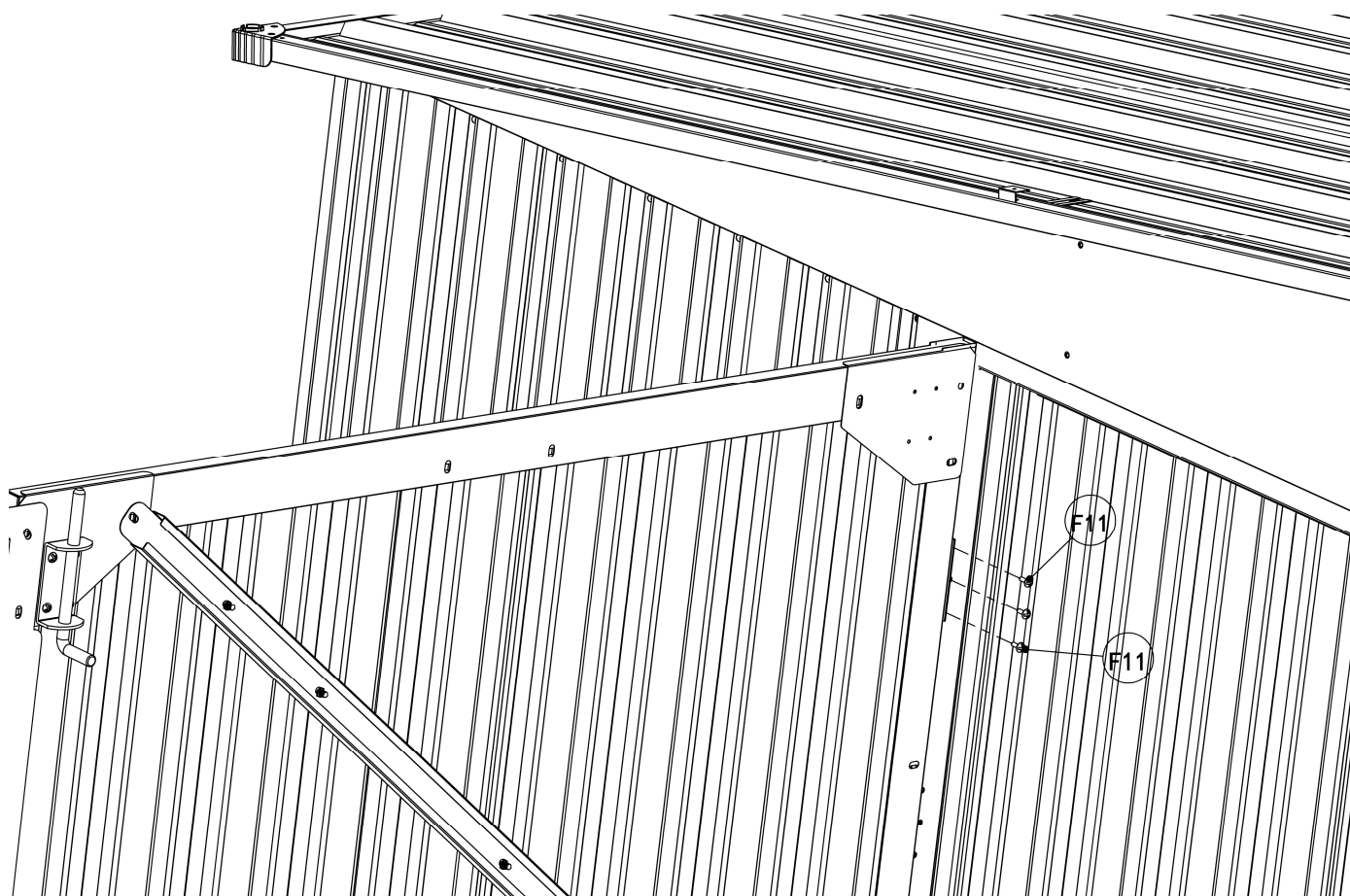
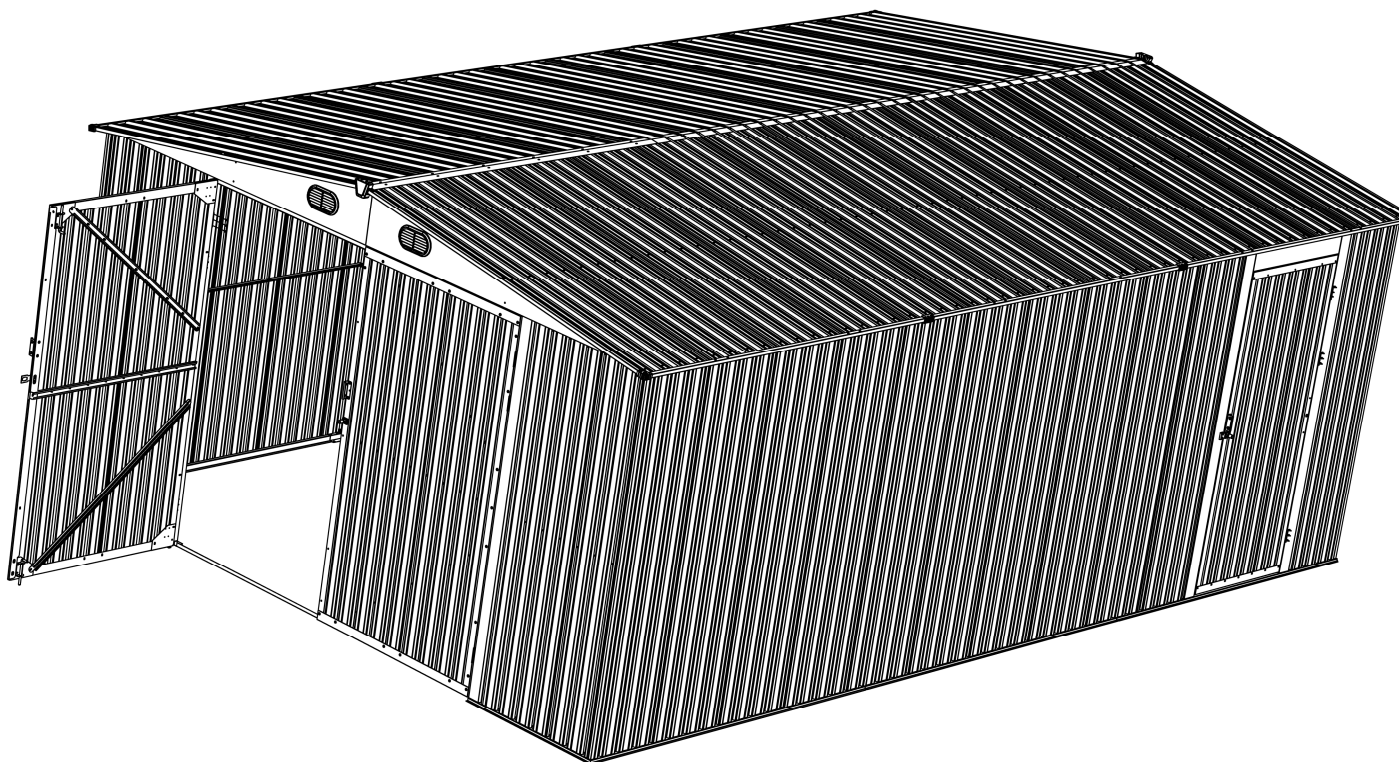

## 7. Final Assembly/Assemblage final

1. Remove two 23 if needed.
2. Cover the exposed F1 in the house with F8.

1. Retirez 2 morceaux de 17 si nécessaire
2. Exposez F1 à l'intérieur et à l'extérieur de la maison et applique

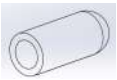
Part	No	Qty
	F8	302

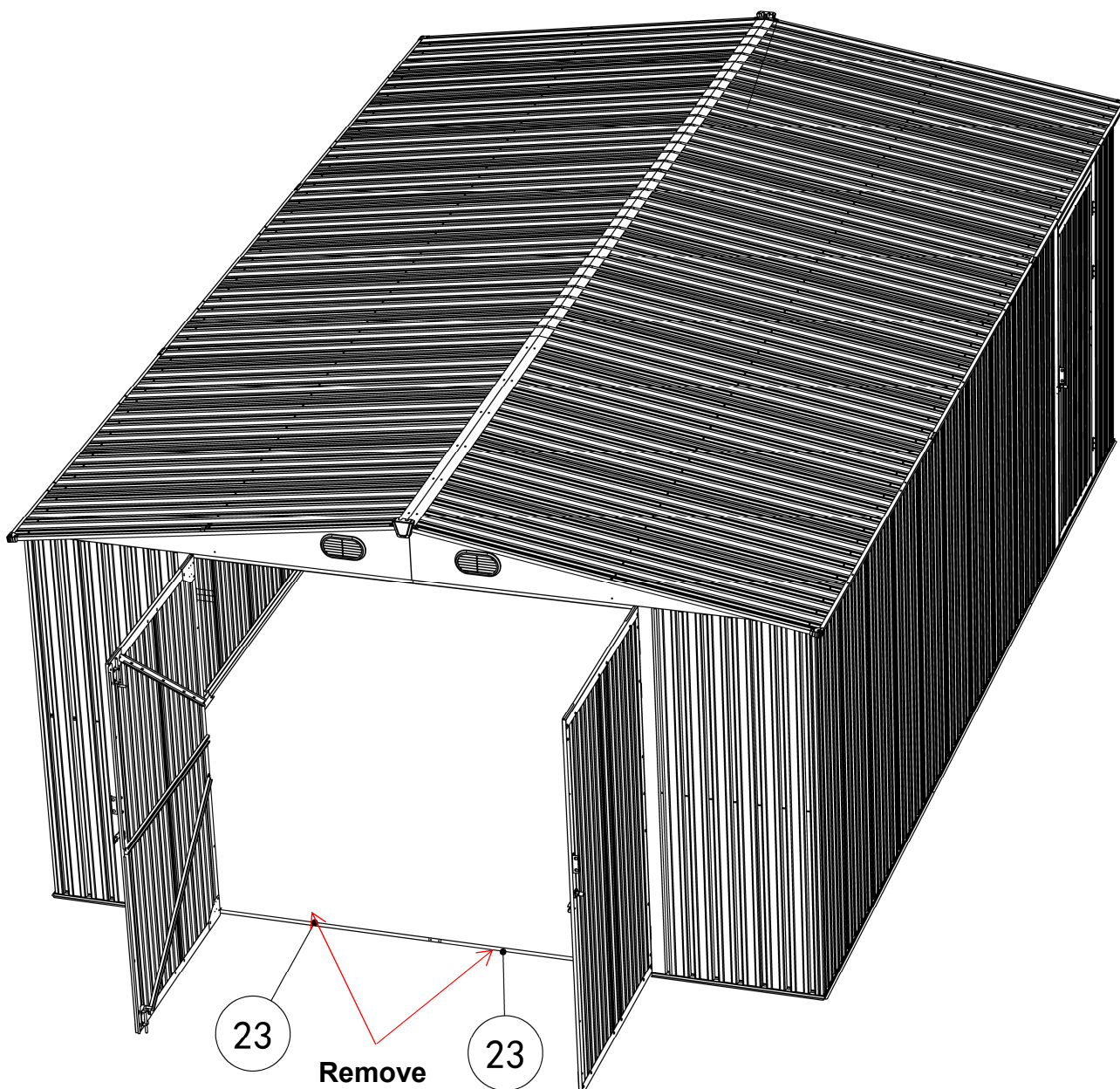

## This accessory is a supplementary part for door installation/Cet accessoire est une pièce supplémentaire pour l'installation de la porte



When the hinge can not lock tightly Use L1 and R1 to adjust./Lorsque la charnière ne peut pas se verrouiller fermement Utilisez L1 et R1 pour régler.

When the ground is uneven or door inclined. Put R2 outside to adjust./Lorsque le sol est irrégulier ou la porte inclinée. Mettez R2 à l'extérieur pour ajuster.

### Right Door

1. When the hinge can not lock tightly. First remove the F11 screw on the D14 on the right door, and then put R1 inside of D14 and lock with S1 and F11. Then install D14 on the door./Lorsque la charnière ne peut pas se verrouiller fermement. Retirez d'abord la vis F11 du D14 sur la porte droite, puis placez R1 à l'intérieur de D14 et verrouillez avec S1 et F11. Installez ensuite le D14 sur la porte.

2. When the ground is uneven or door inclined. Put R2 outside of D14 and lock with S1 and F11. Accordi to the gap of the door to determine the required QTY of R2./Lorsque le sol est inégal ou que la porte est inclinée. Mettez R2 à l'extérieur de D14 et verrouillez avec S1 et F11. Selon l'écart de la porte pour déterminer la quantité requise de R2.

Part	No	Qty	Part	No	Qty	Part	No	Qty
	R1	1		L1	1		R2	4

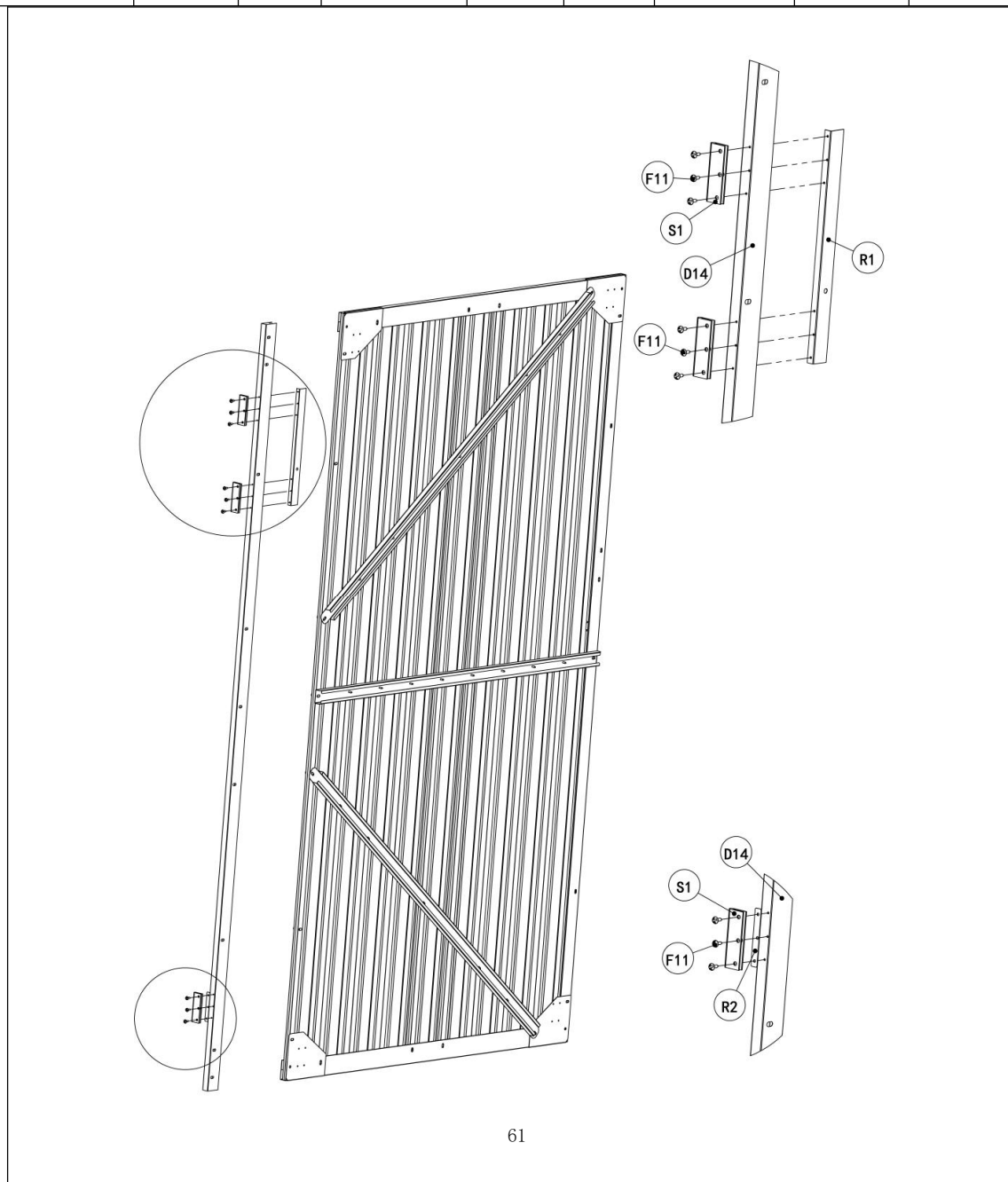

## Left Door/Porte gauche

1. When the hinge can not lock tightly. First remove the F11 screw on the D6 on the left door, and then put L1 inside of D6 and lock with S1 and F11. Then install D6 on the door.

2. When the ground is uneven or door inclined. Put R2 outside of D6 and lock with S1 and F11. According to the gap of the door to determine the required QTY of R2.

1. Lorsque la charnière ne peut pas se verrouiller fermement. Retirez d'abord la vis F11 du sur la porte gauche, puis placez L1 à l'intérieur du D6 et verrouillez avec S1 et F11. Installez ensuite D6 sur la porte.

2. Lorsque le sol est inégal ou que la porte est inclinée. Placez R2 à l'extérieur de D6 verrouillez avec S1 et F11. En fonction de l'écart de la porte, déterminez la quantité requise de R2.

