

Features

- VibrAcoustic calms and soothes with sound vibration technology.
- Six concealed speakers send sound waves through the water to gently massage the body.
- Four original instrumental compositions offer different levels of relaxation.
- Plug in your smart phone, tablet, or MP3 player via auxiliary-in cable. Add your own receiver to stream wirelessly via Bluetooth®.
- Customize your experience with the high-resolution color touch screen.
- Fully adjustable volume above and below the water.
- Functions as a hydrotherapy bath when full of water and a stereo system when empty.
- Bask™ heated surface creates spa-like relaxation with soothing warmth on your back and neck.
- Three heat settings allow you to customize the surface temperature.
- Chromatherapy lighting allows you to select a preferred color scheme to suit your mood.
- Clearflo slotted overflow for deep soaking.
- Tile flange helps prevent water from seeping behind wall and simplifies alcove installation.
- Right-hand drain.
- *The BLUETOOTH® word mark and logos are registered trademarks owned by Bluetooth SIG, Inc. and any use of such marks by Kohler Co. is under license. Other trademarks and trade names are those of their respective owners.
- 60 " (1524 mm) x 30 " (762 mm) x 19 " (483 mm)

Material

- Acrylic

Hydrotherapy

- VibrAcoustic
- Chromatherapy

Installation

- Three-wall alcove.



ADA

Codes/Standards











CSA B45.5/IAPMO Z124
ASTM E162
ASTM E662
UL 1795
CSA C22.2 No. 218.2
ADA
ICC/ANSI A117.1

KOHLER® One-Year Limited Warranty KOHLER® Electronic Faucets, Valves, and Controls - Five-Year Limited Warranty

See website for detailed warranty information.

Available Color/Finishes

Color tiles intended for reference only.

Color	Code	Description
	0	White
	96	Biscuit
	47	Almond
	NY	Dune
	95	Ice™ Grey
	G9	Sandbar
	33	Mexican Sand™
	K4	Cashmere
	58	Thunder™ Grey
	7	Black Black™

No change in measurement if connected with drain illustrated. (K-7272)

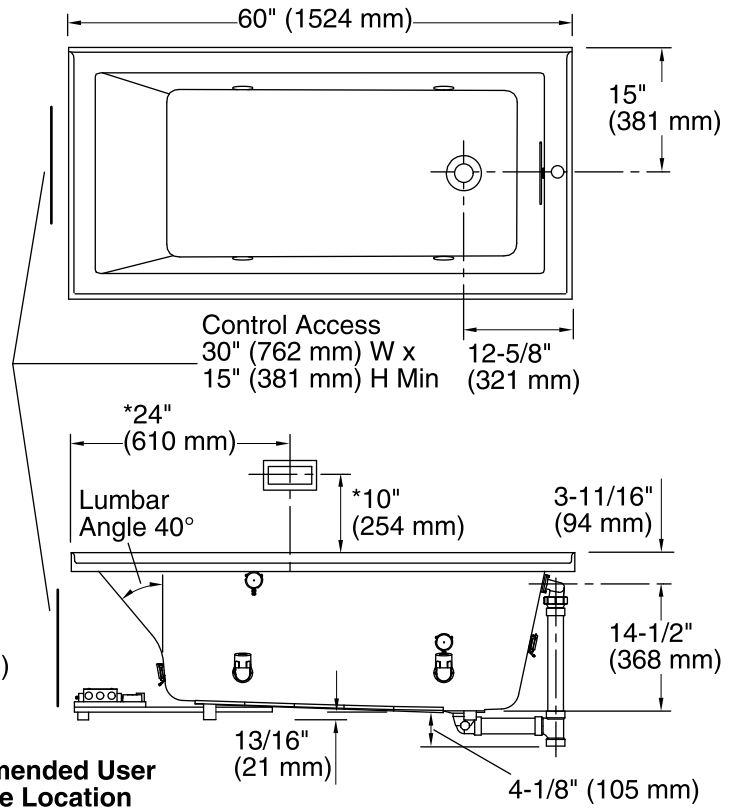
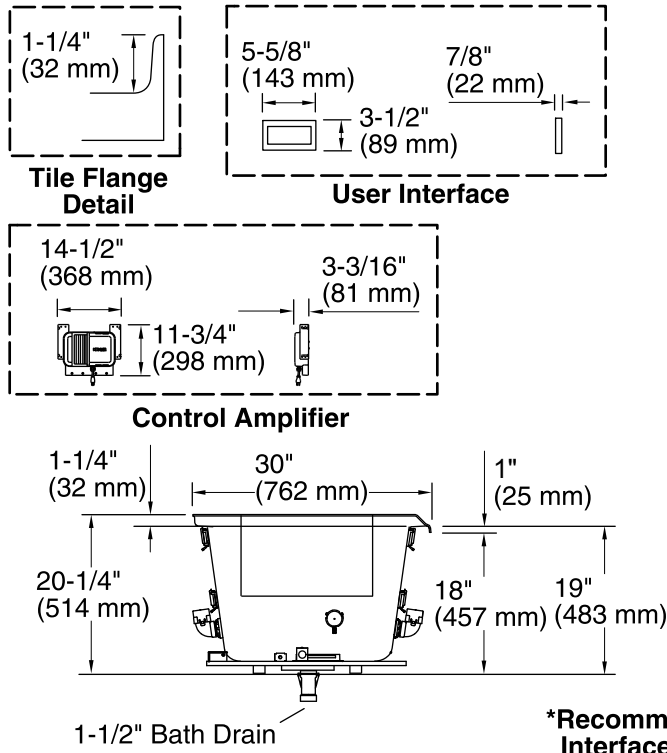

Required Electrical Service

One dedicated circuit required, protected with Class A Ground-Fault Circuit-Interrupter (GFCI) or Residual Current Device (RCD).

Amplifier, Heater: 120 V, 15 A, 50/60 Hz

Technical Information

All product dimensions are nominal.

Installation:	Alcove with Flange
Drain location:	Reversible
Basin area, bottom:	42-7/16" x 20" (1078 mm x 508 mm)
Basin area, top:	54-5/16" x 24-1/4" (1380 mm x 616 mm)
Weight:	85 lbs (38.6 kg)
Minimum floor load:	50 lbs/ft ² (244.1 kg/m ²)
Water depth:	15-1/8" (384 mm)
Water capacity:	59.8 gal (226.4 L)
Electrical rating:	Amplifier: 120 V, 50/60 Hz, 15 W Heater: 120 V, 1.1 A, 50/60 Hz, 65 W

Notes

Install this product according to the installation guide. Ensure all components are functional before completing the installation. Control amplifier fits 16" (406 mm) center studs. 25' (7.6 m) cables are included.

Locate the bath within 24" (610 mm) of a GFCI-protected 120 V, 15 A grounded electrical outlet. A second grounded outlet within the wall framing must be within 24" (610 mm) of the planned control amplifier. One electrical service may be used for the entire bath and related electrical components.

Hot water supply should be 70% of capacity or greater. Installations will vary.

ADA compliant when installed to the specific requirements of these regulations.